



US00D932975S

(12) **United States Design Patent**
O'Neill

(10) **Patent No.:** **US D932,975 S**

(45) **Date of Patent:** **** Oct. 12, 2021**

(54) **VEHICLE WHEEL**

(71) Applicant: **JAGUAR LAND ROVER LIMITED,**
Coventry (GB)

(72) Inventor: **Michael O'Neill,** Coventry (GB)

(73) Assignee: **JAGUAR LAND ROVER LIMITED,**
Coventry (GB)

(**) Term: **15 Years**

(21) Appl. No.: **29/745,466**

(22) Filed: **Aug. 6, 2020**

(30) **Foreign Application Priority Data**

Feb. 6, 2020 (EM) 007667720

(51) **LOC (13) Cl.** **12-16**

(52) **U.S. Cl.**
USPC **D12/209**

(58) **Field of Classification Search**

USPC D12/204-213; D21/563

CPC B60B 7/00; B60B 7/02; B60B 7/04; B60B
7/01; B60B 7/06; B60B 3/02; B60B 3/04;
B60B 3/06; B60B 3/10; B60B 1/00;
B60B 1/08; B60B 1/10; B60B 1/12

See application file for complete search history.

(56) **References Cited**

U.S. PATENT DOCUMENTS

D626,905 S * 11/2010 Camacho D12/209
D663,248 S * 7/2012 Kogawa D12/209
D671,876 S * 12/2012 Roura D12/209
D695,184 S * 12/2013 Pollmann D12/209

D695,191 S * 12/2013 Kogawa D12/209
D723,989 S * 3/2015 Morikawa D12/209
D755,694 S * 5/2016 Valencia Pollex D12/209
D783,491 S * 4/2017 Valencia Pollex D12/209
D818,926 S * 5/2018 Miyazawa D12/209
D835,561 S * 12/2018 Hayashi D12/209
D847,719 S * 5/2019 Rosello Visa D12/209
D853,304 S * 7/2019 Pollex D12/209
D859,266 S * 9/2019 Valencia Pollex D12/209
D862,352 S * 10/2019 Bjerke D12/209
D879,000 S * 3/2020 Wang D12/209
D880,395 S * 4/2020 Valencia Pollex D12/209
D884,575 S * 5/2020 Rosello Visa D12/209
D911,243 S * 2/2021 Piaskowski D12/209
D914,570 S * 3/2021 Chan D12/209

* cited by examiner

Primary Examiner — Stacia A Cadmus

(74) *Attorney, Agent, or Firm* — Reising Ethington P.C.

(57) **CLAIM**

The ornamental design for a vehicle wheel, as shown and described.

DESCRIPTION

FIG. 1 is a frontside perspective view of the vehicle wheel;
FIG. 2 is a rear side perspective view thereof;
FIG. 3 is a front view thereof;
FIG. 4 is a rear view thereof;
FIG. 5 is a left side view thereof;
FIG. 6 is a right side view thereof;
FIG. 7 is a top view thereof; and,
FIG. 8 is a bottom view thereof.

The broken lines shown in the drawings depict portions of the vehicle wheel that form no part of the claimed design.

1 Claim, 8 Drawing Sheets

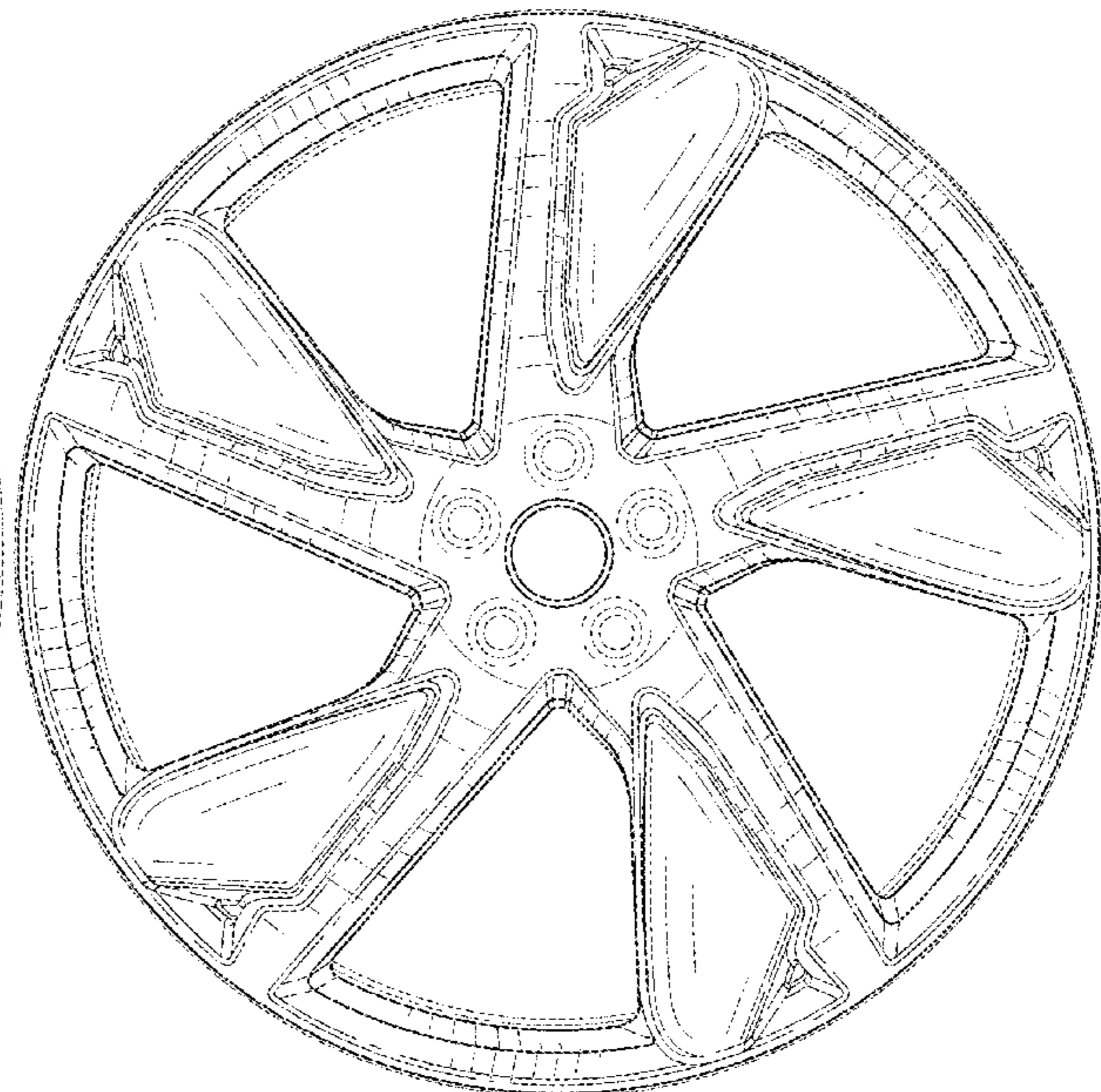
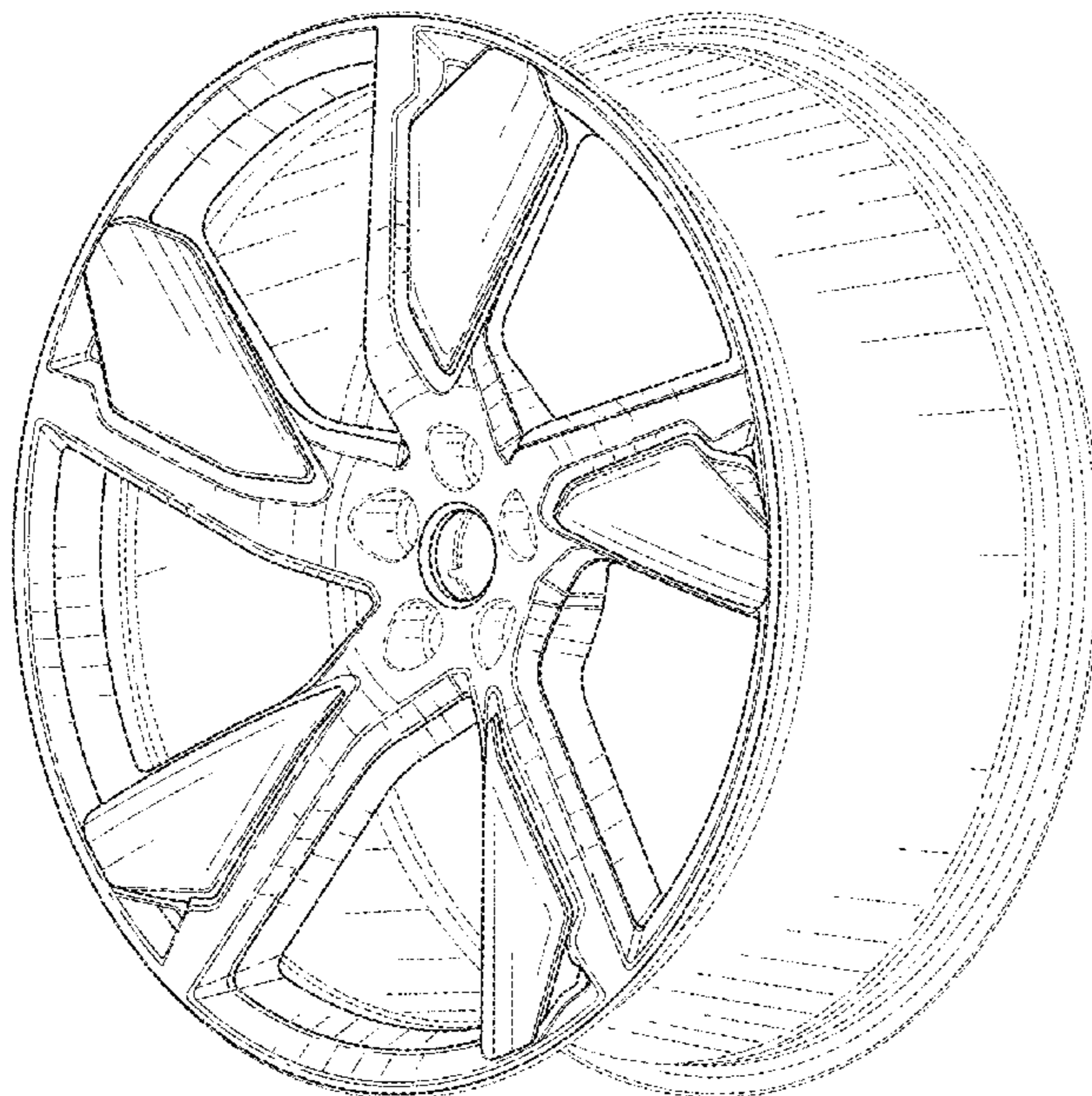

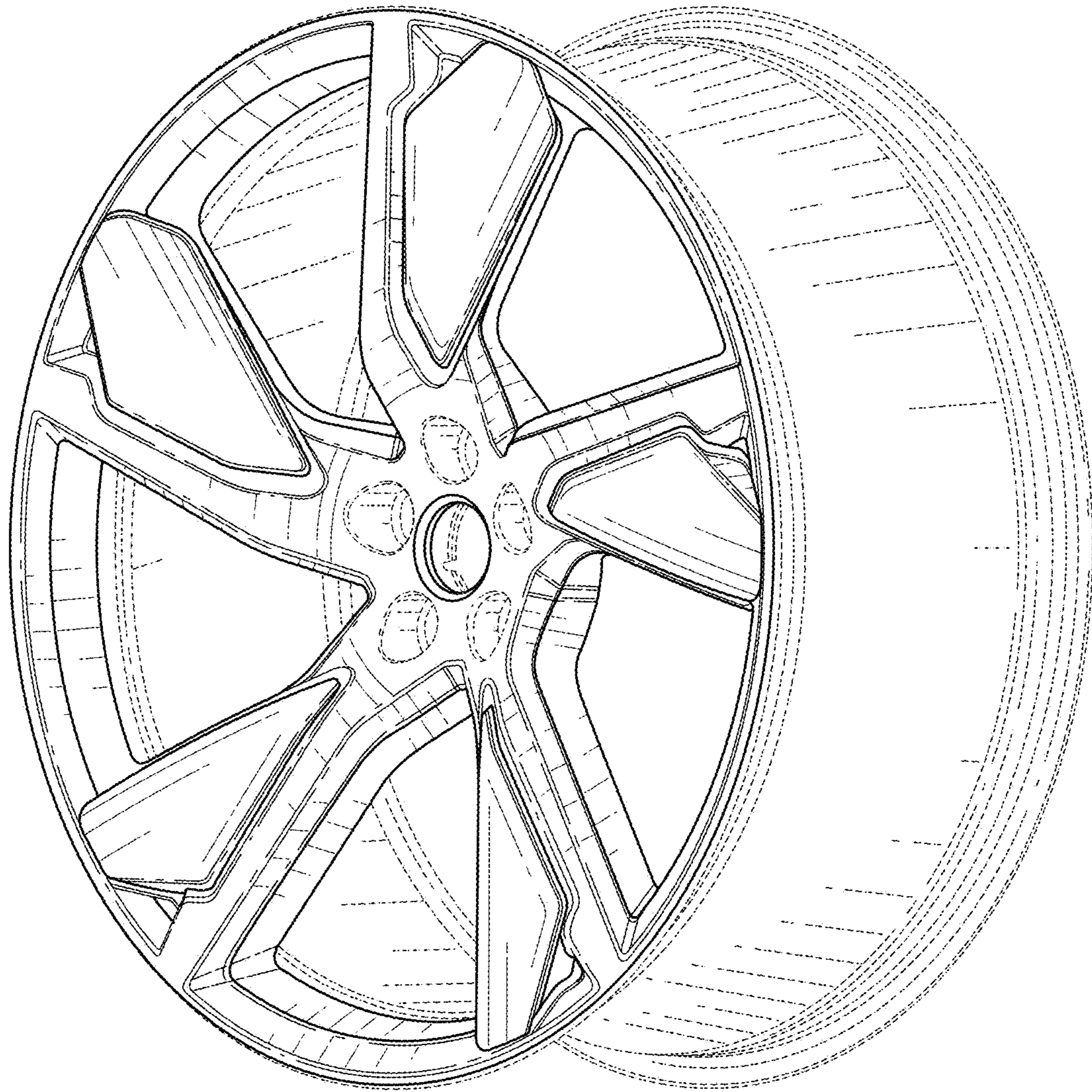

FIG. 1

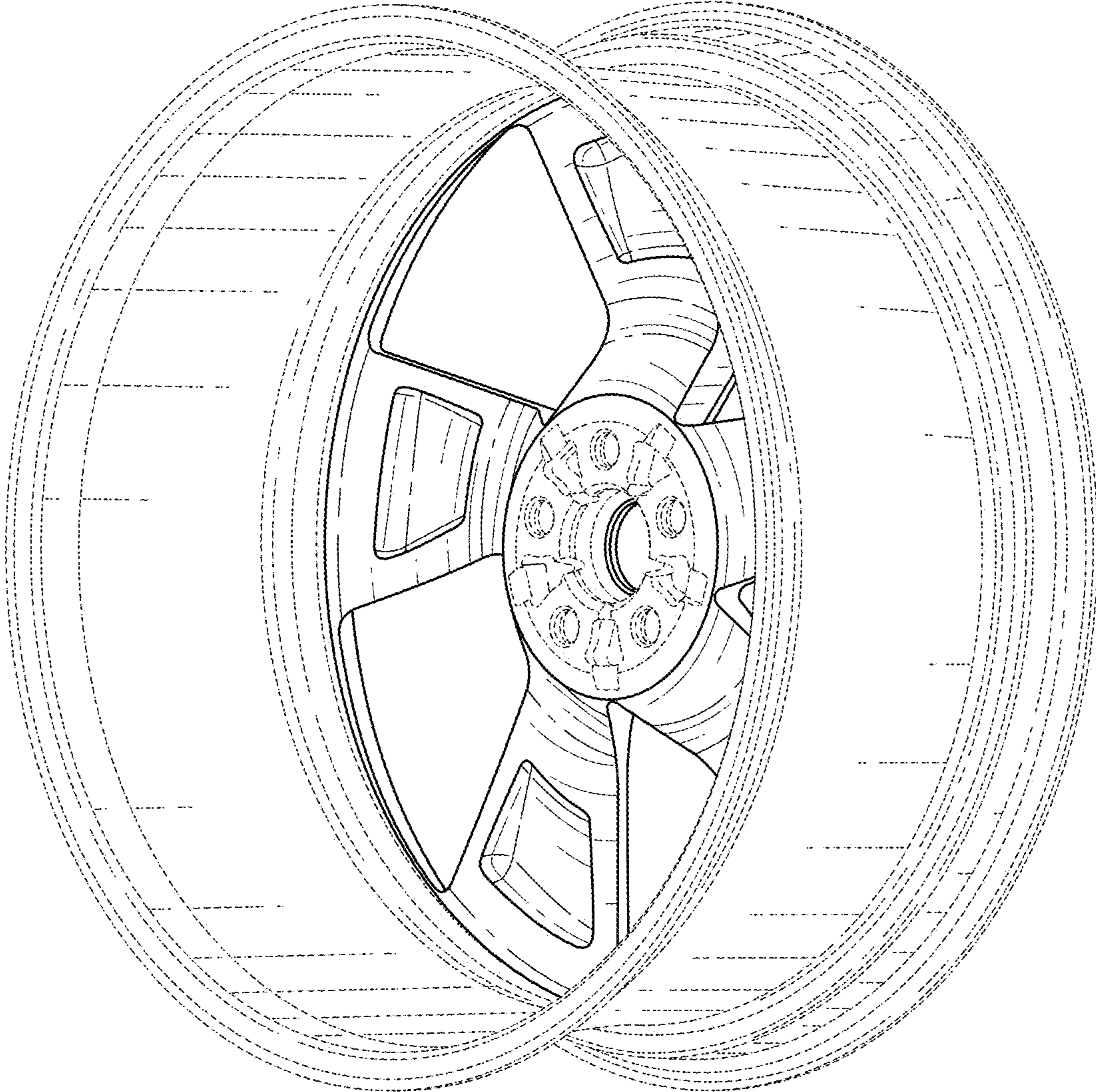

FIG. 2

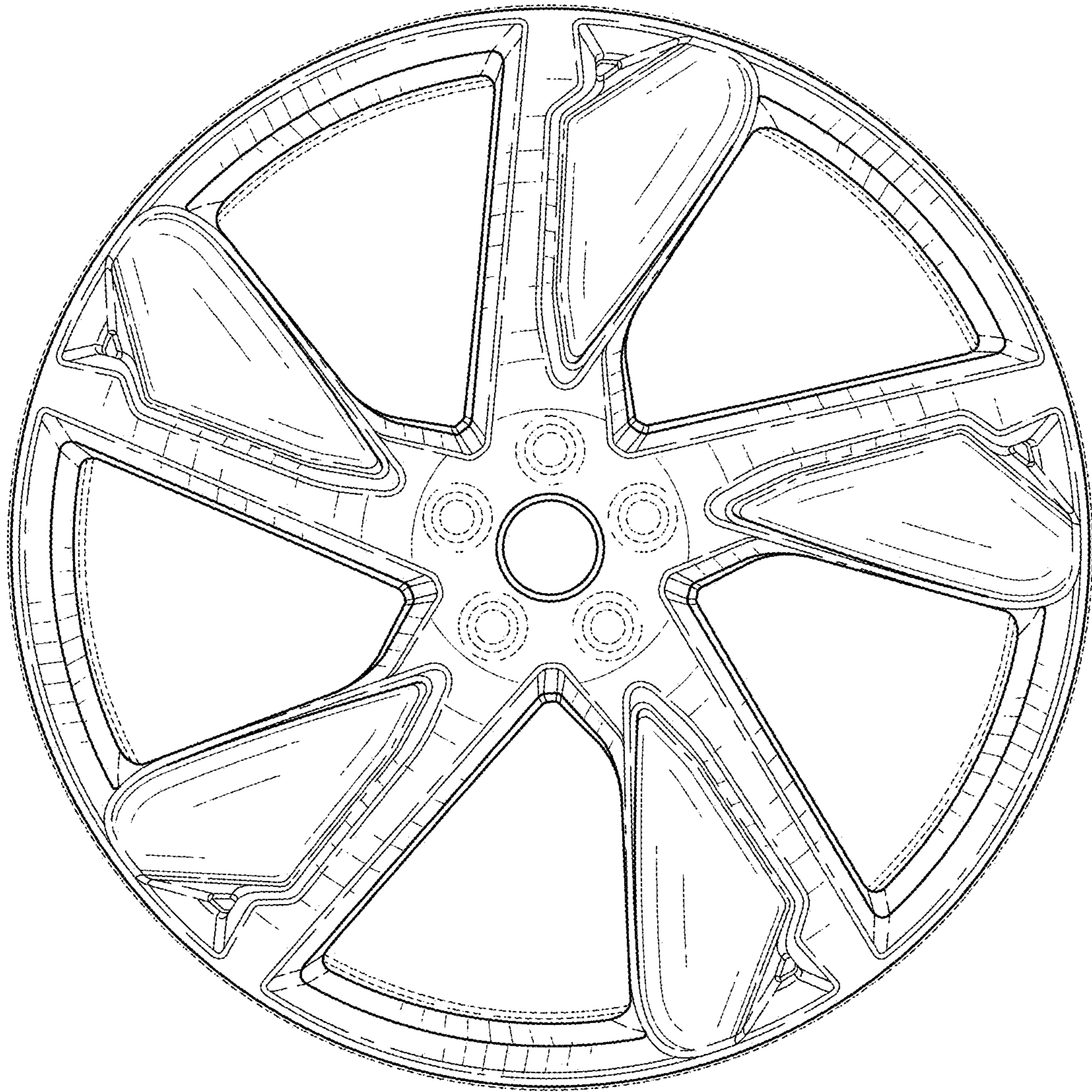

FIG. 3

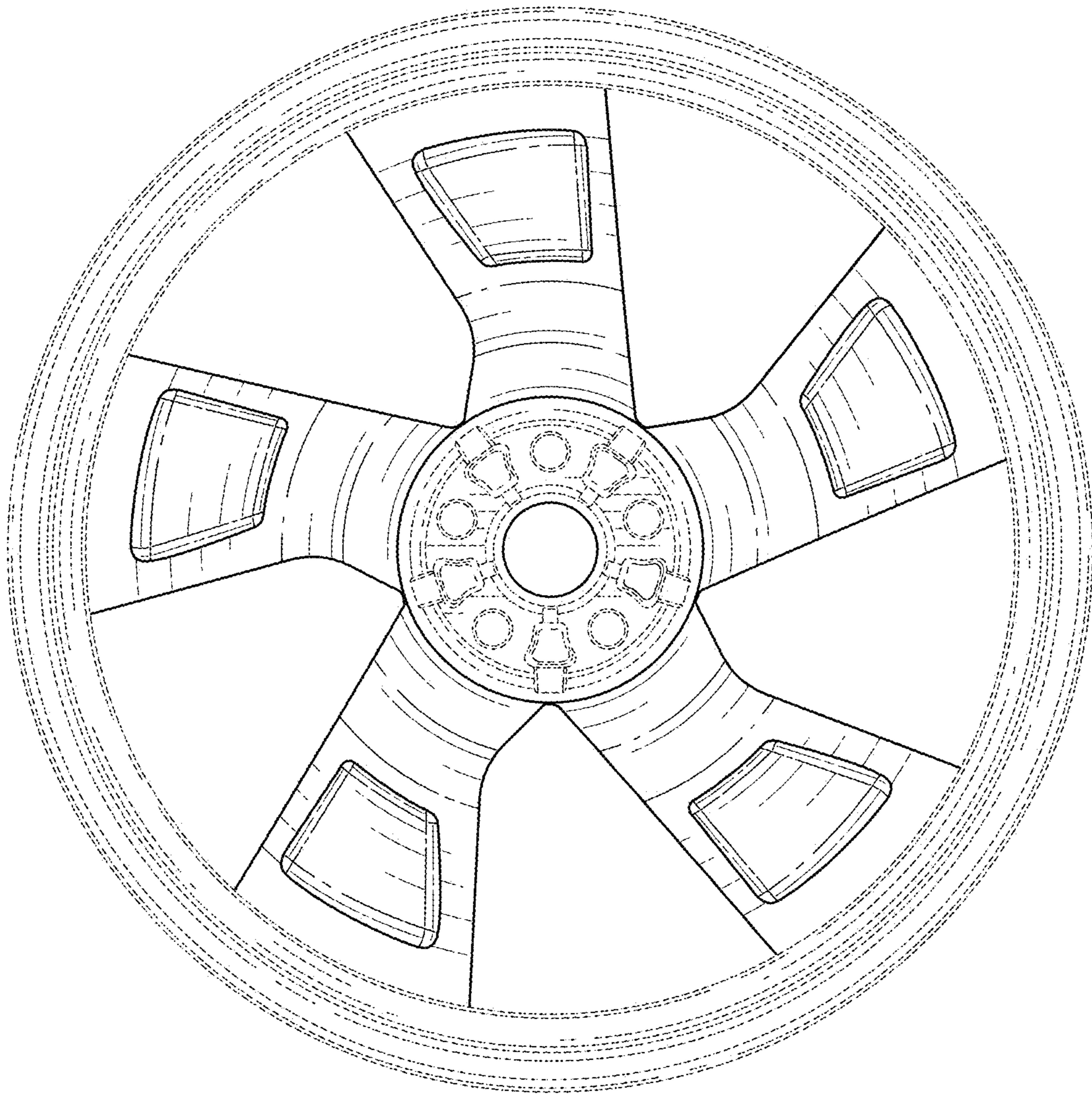

FIG. 4

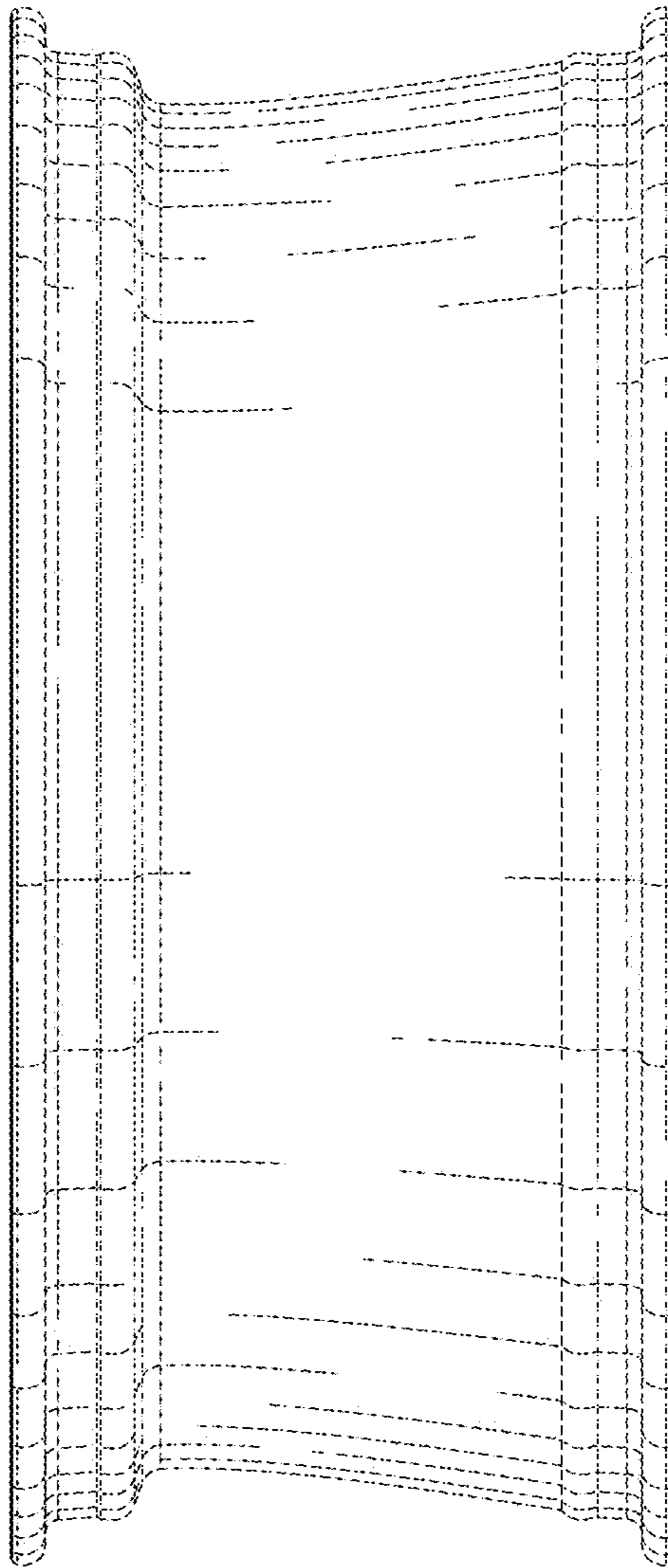

FIG. 5

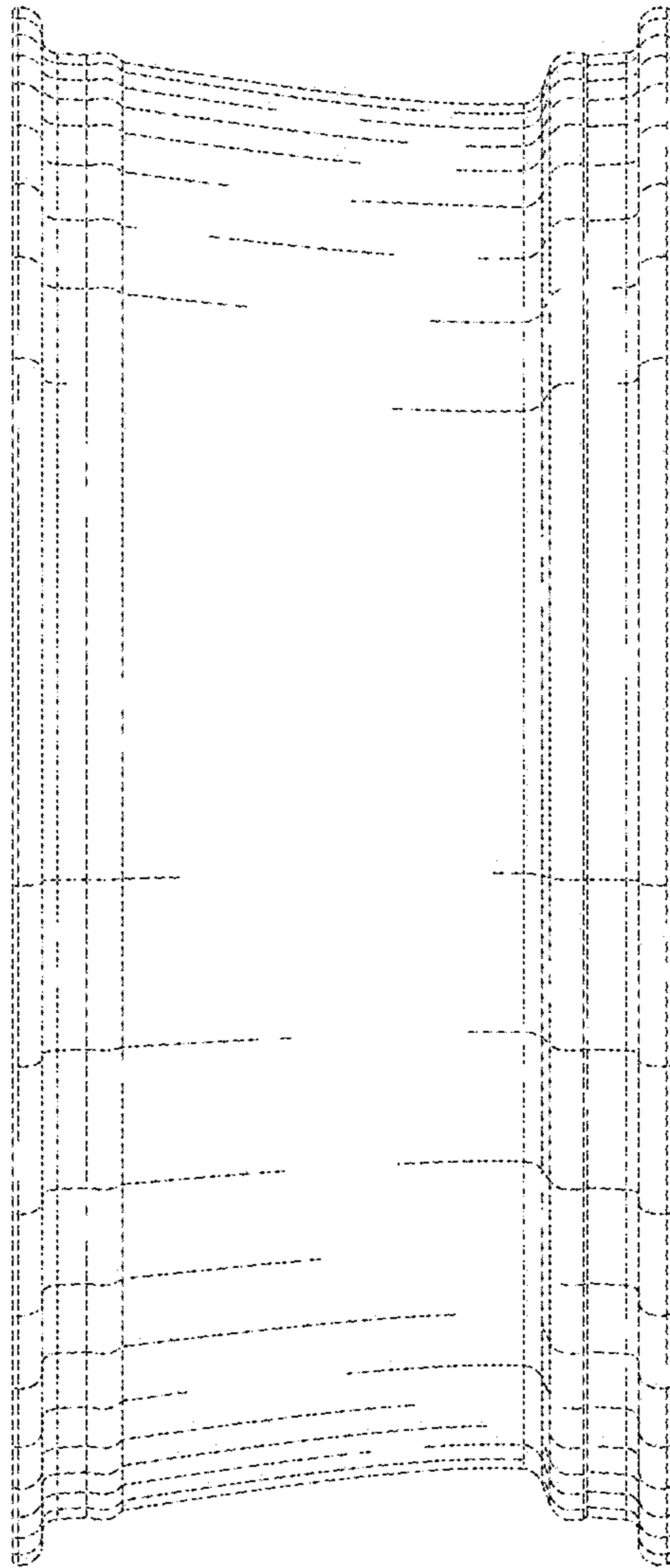

FIG. 6

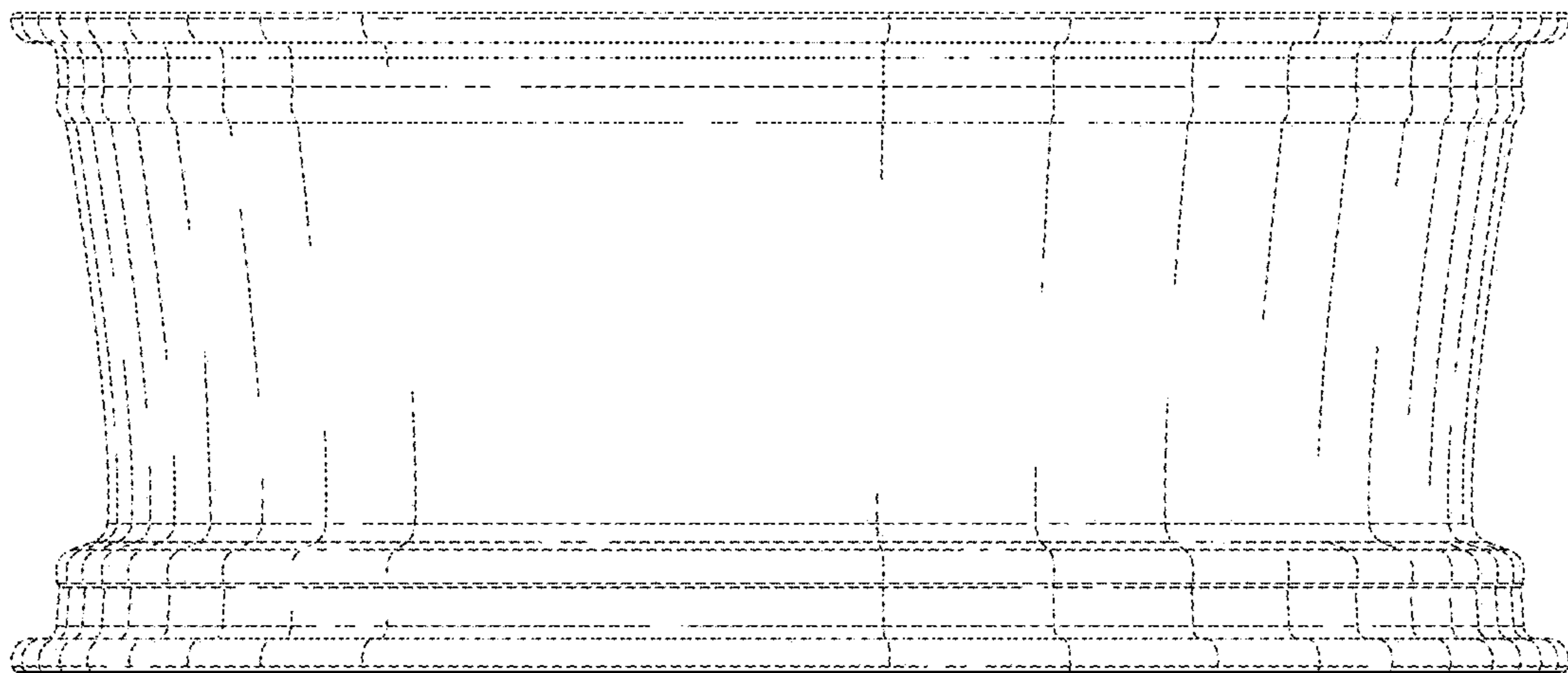

FIG. 7

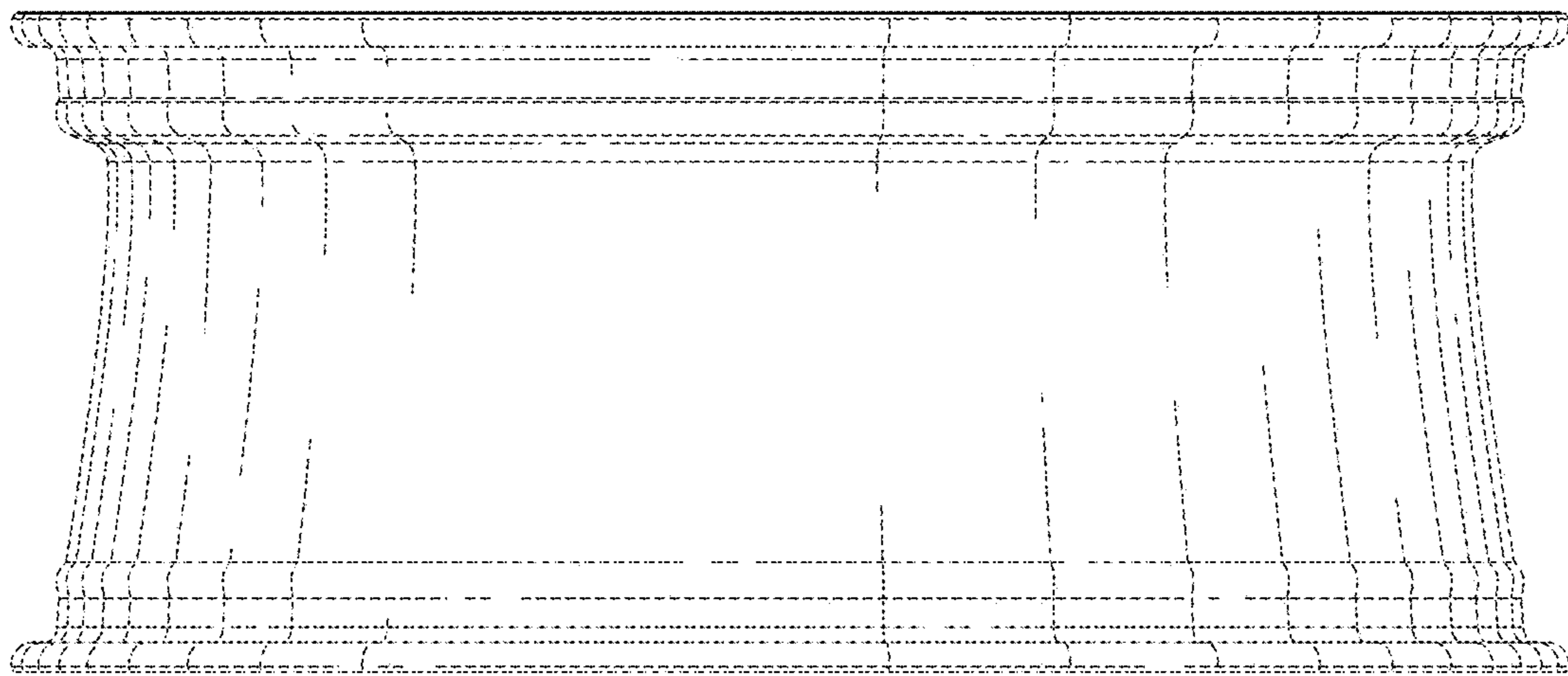

FIG. 8