



US00D931812S

(12) **United States Design Patent** (10) **Patent No.:** **US D931,812 S**  
**Nook et al.** (45) **Date of Patent:** **\*\* Sep. 28, 2021**

(54) **BATTERY TERMINAL** 5,190,484 A \* 3/1993 Kennedy ..... H01R 11/282  
439/371  
(71) Applicant: **THE NOCO COMPANY**, Glenwillow, OH (US) D361,750 S \* 8/1995 Ansley ..... D13/151  
5,595,511 A \* 1/1997 Okada ..... H01R 11/282  
439/762  
(72) Inventors: **Jonathan Lewis Nook**, Gates Mills, OH (US); **James Richard Stanfield**, Peoria, AZ (US); **Derek Michael Underhill**, Tempe, AZ (US) D399,487 S \* 10/1998 Awbrey ..... D13/120  
D667,790 S \* 9/2012 Osaki ..... D13/120  
D772,816 S \* 11/2016 DeKeuster ..... D13/119  
9,608,254 B1 \* 3/2017 Freitag ..... H01R 11/283  
D836,553 S \* 12/2018 Yamamoto ..... D13/119  
D836,554 S \* 12/2018 Yamamoto ..... D13/119  
(73) Assignee: **THE NOCO COMPANY**, Glenwillow, OH (US) D853,309 S \* 7/2019 Wallace ..... D12/223  
2002/0114994 A1 \* 8/2002 Yabuki ..... H01M 2/305  
429/178  
(\*\*) Term: **15 Years** 2016/0111799 A1 \* 4/2016 Kato ..... H01M 2/305  
439/756

\* cited by examiner

(21) Appl. No.: **29/705,660**

(22) Filed: **Sep. 13, 2019**

*Primary Examiner* — Jennifer O King  
(74) *Attorney, Agent, or Firm* — Vorys, Sater, Seymour and Pease LLP; William L. Klima

**Related U.S. Application Data**

(63) Continuation of application No. 16/564,758, filed on Sep. 9, 2019.

(51) **LOC (13) Cl.** ..... **13-02**

(52) **U.S. Cl.**  
USPC ..... **D13/120**

(58) **Field of Classification Search**  
USPC ..... D13/118, 119, 120, 103, 151, 199;  
D12/223

CPC ..... H01R 11/24; H01R 11/281; H01R 11/283  
See application file for complete search history.

(56) **References Cited**

**U.S. PATENT DOCUMENTS**

3,694,799 A \* 9/1972 Shannon ..... H01R 11/281  
439/726  
5,024,621 A \* 6/1991 Mata ..... H01R 11/281  
439/766

(57) **CLAIM**

The ornamental design for a battery terminal, as shown and described.

**DESCRIPTION**

FIG. 1 is a perspective view of a new design for a battery terminal;

FIG. 2 is a front view thereof;

FIG. 3 is a rear view thereof;

FIG. 4 is a top view thereof;

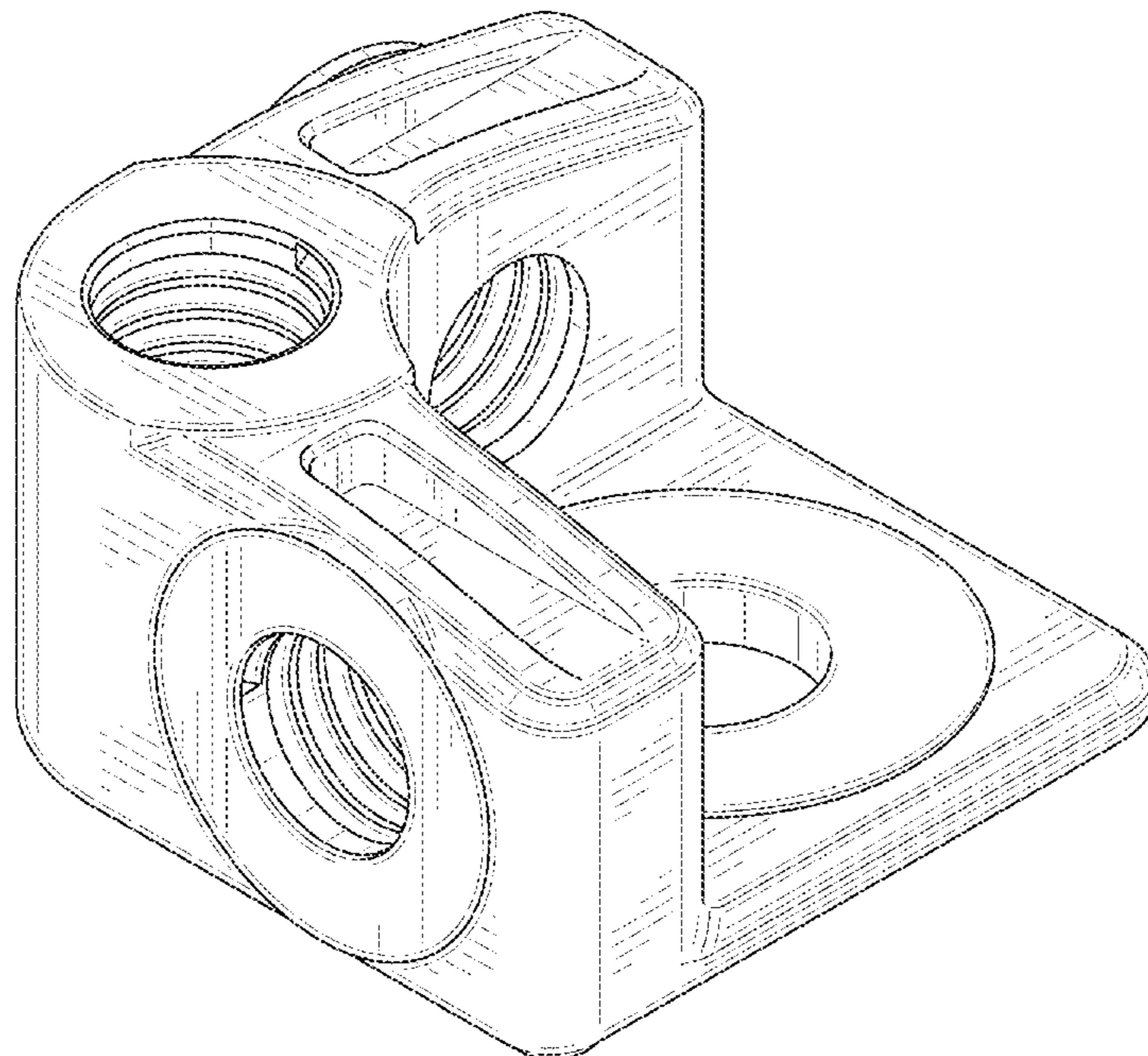
FIG. 5 is a bottom view thereof;

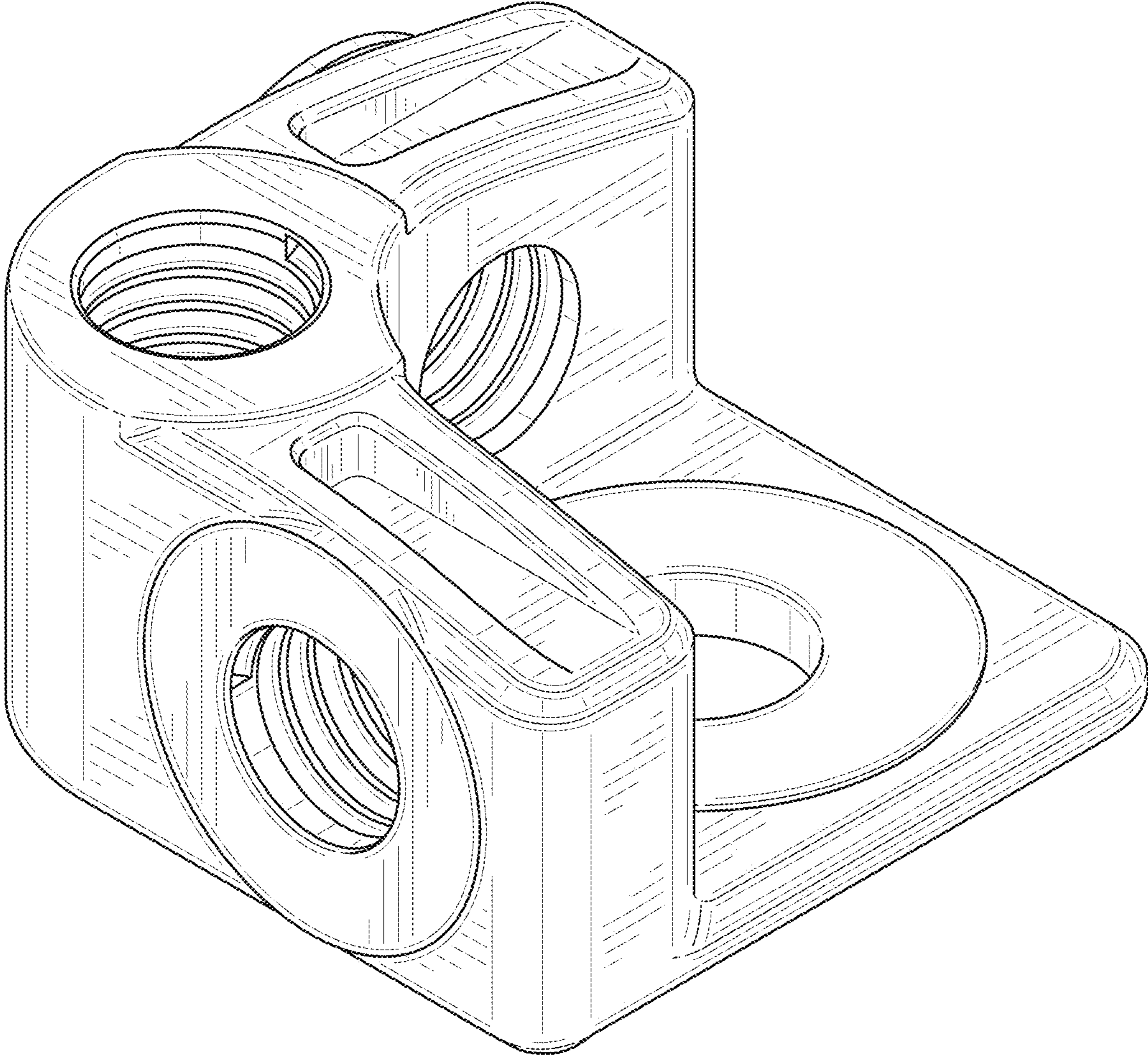
FIG. 6 is a right side view thereof; and,

FIG. 7 is a left side view thereof.

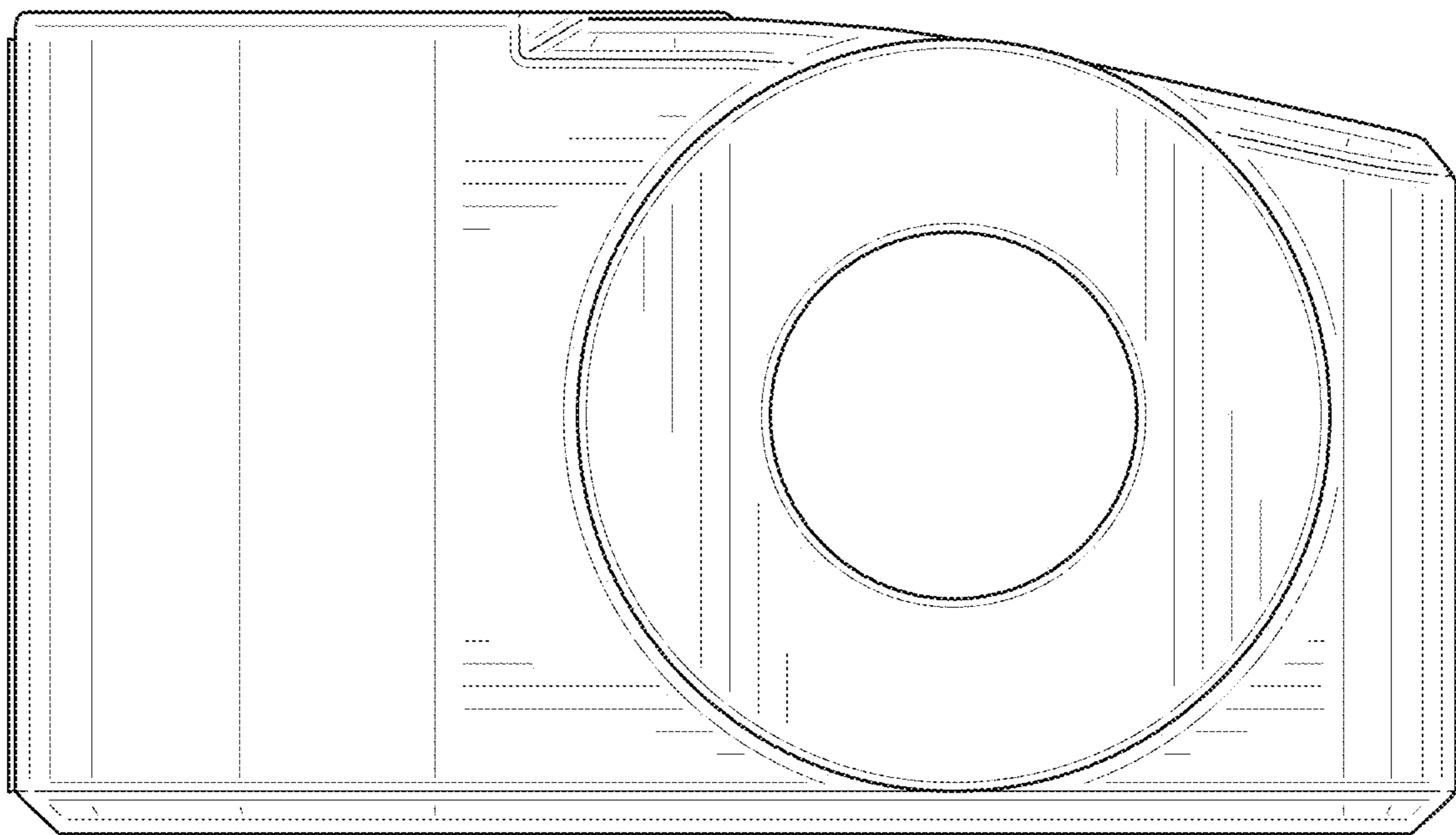
The broken lines shown represent portions of the battery terminal that form no part of the claimed design.

**1 Claim, 7 Drawing Sheets**

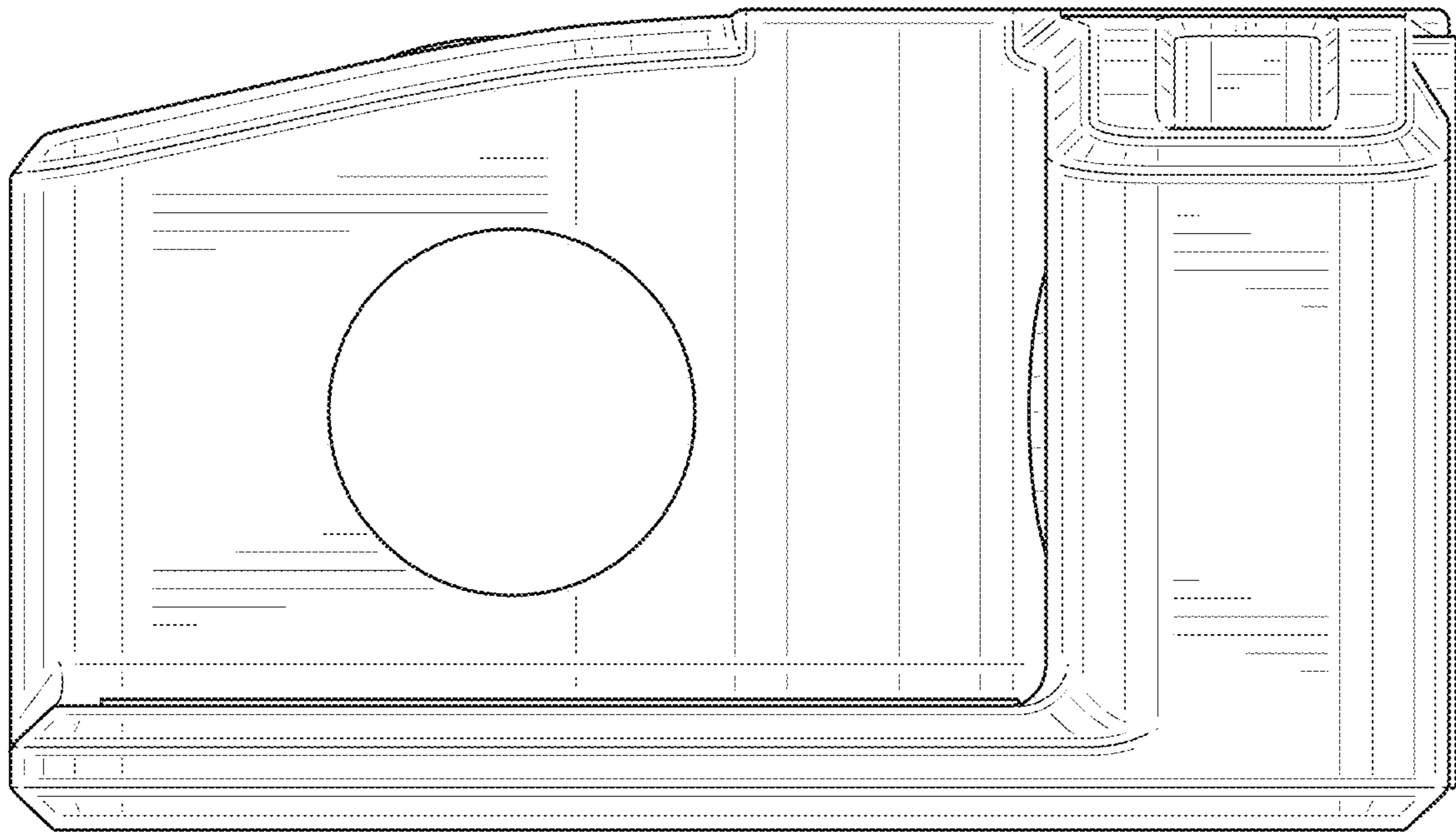




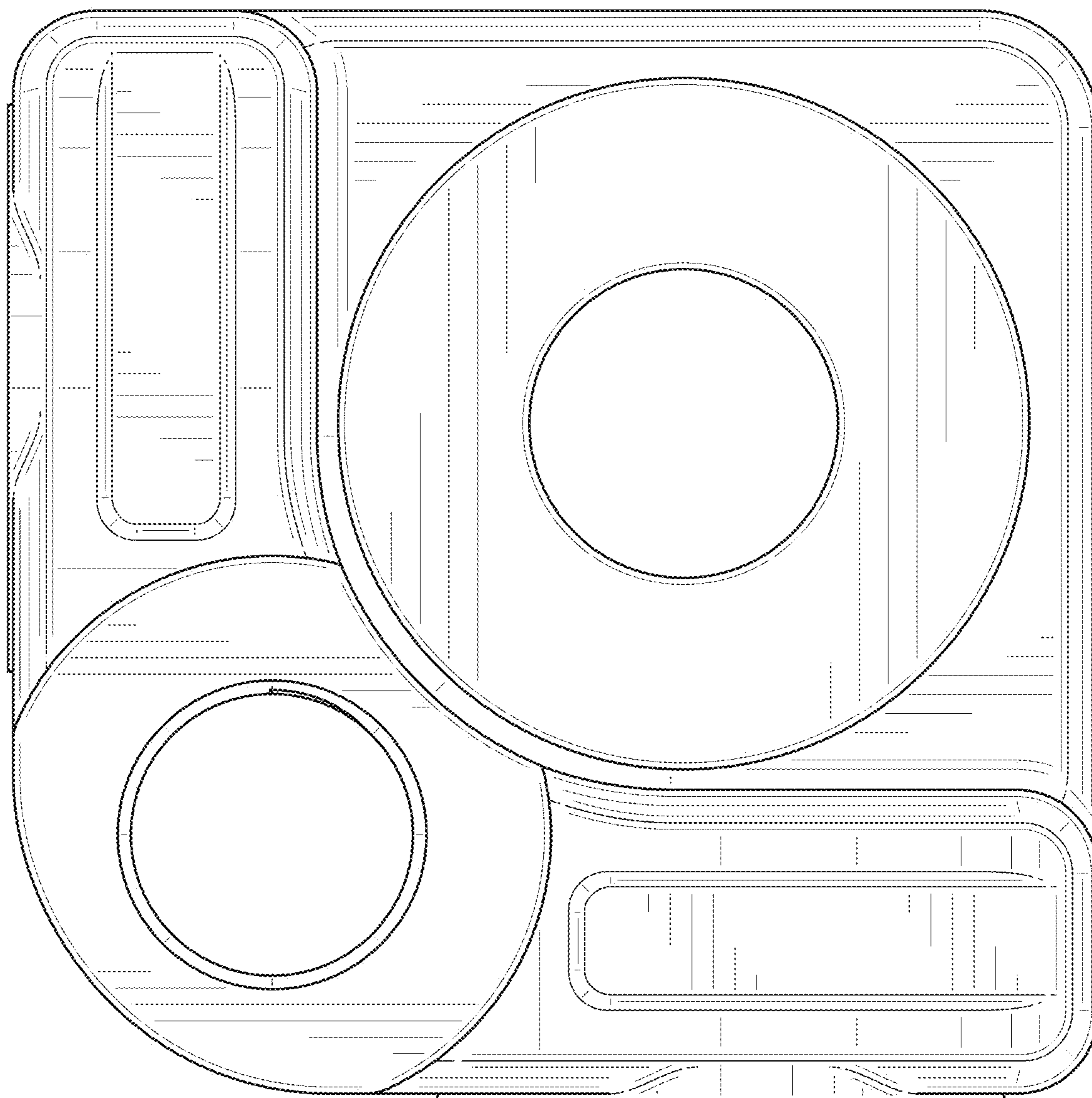
**FIG. 1**



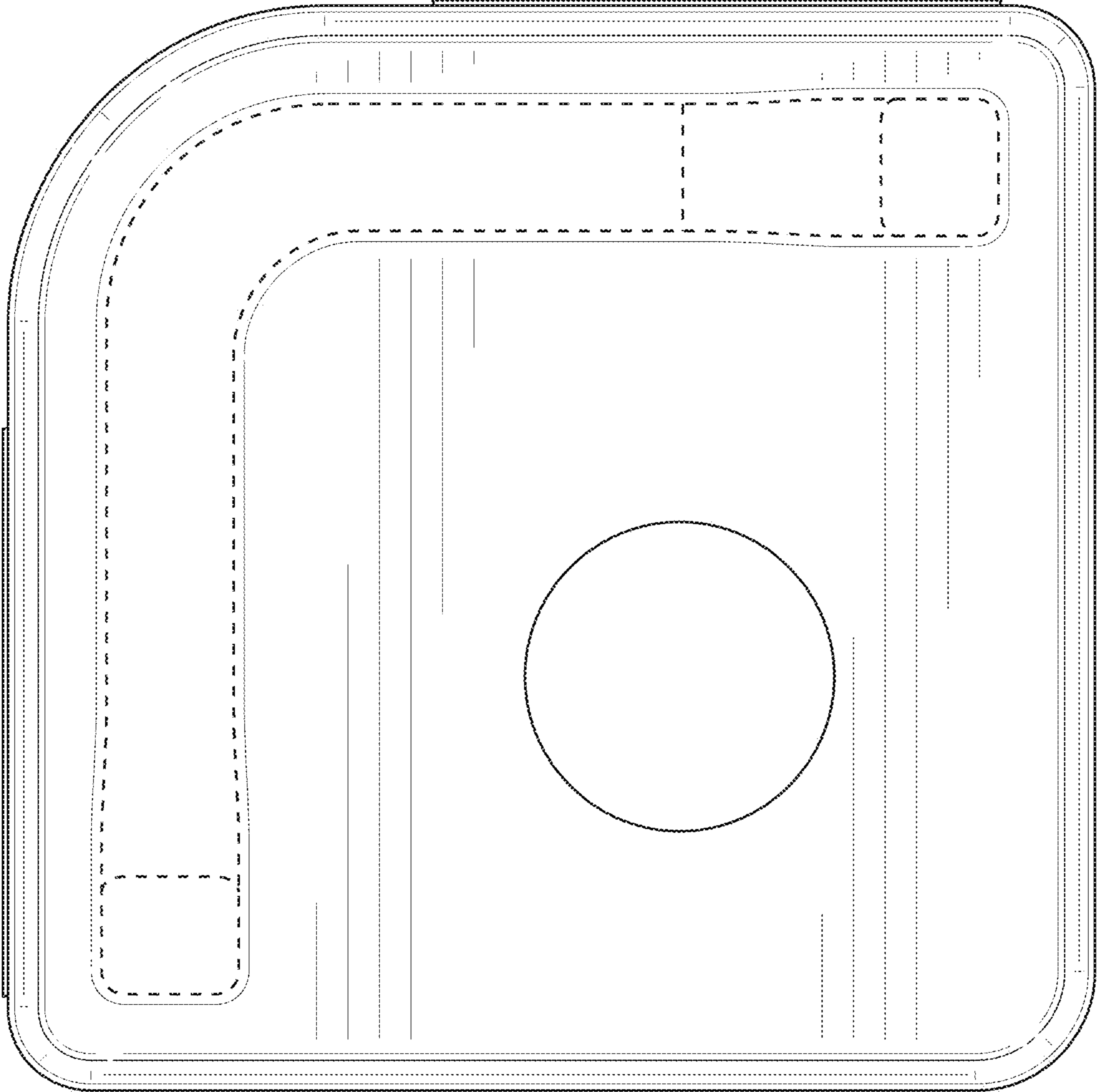
**FIG. 2**



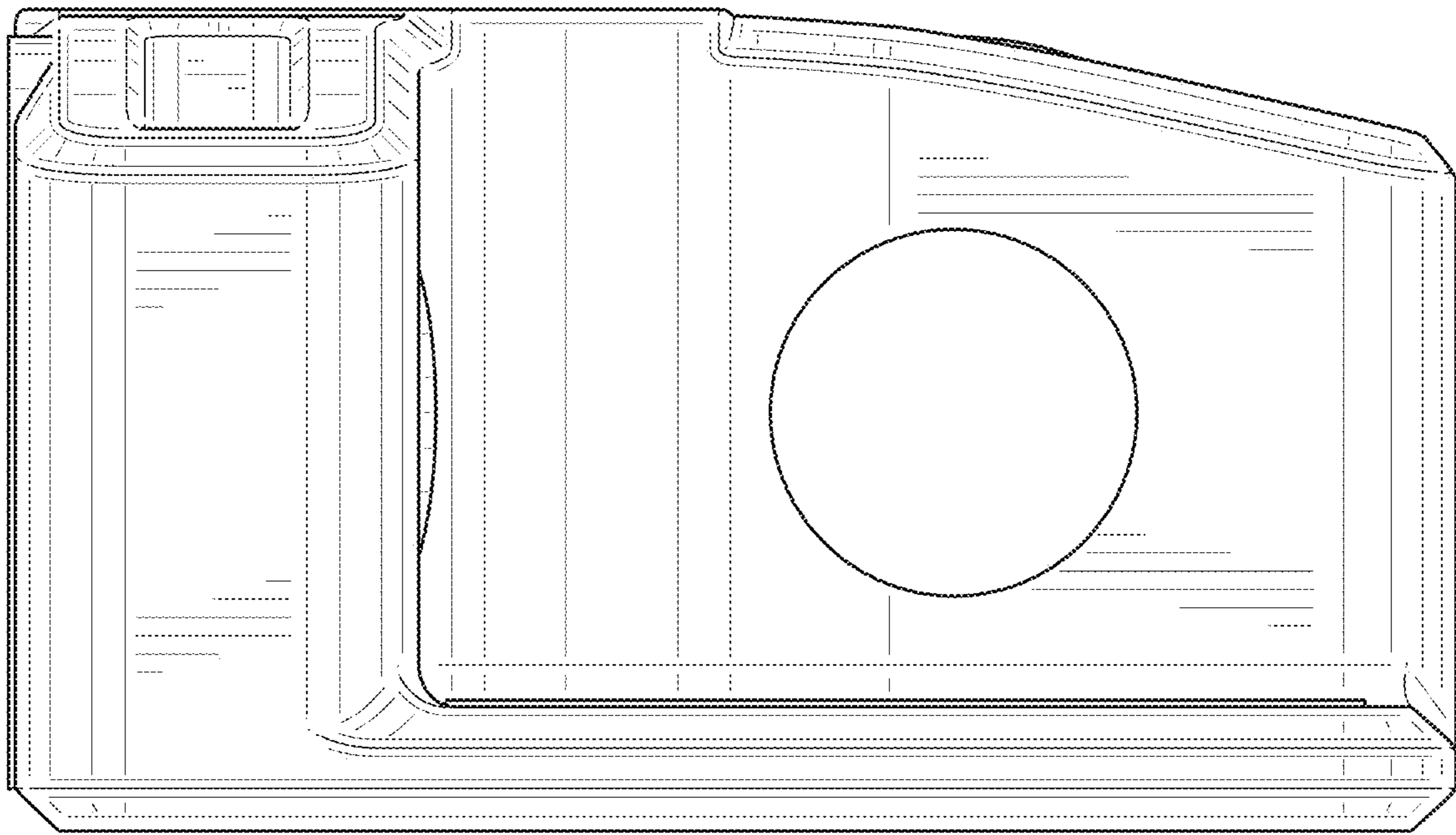
**FIG. 3**



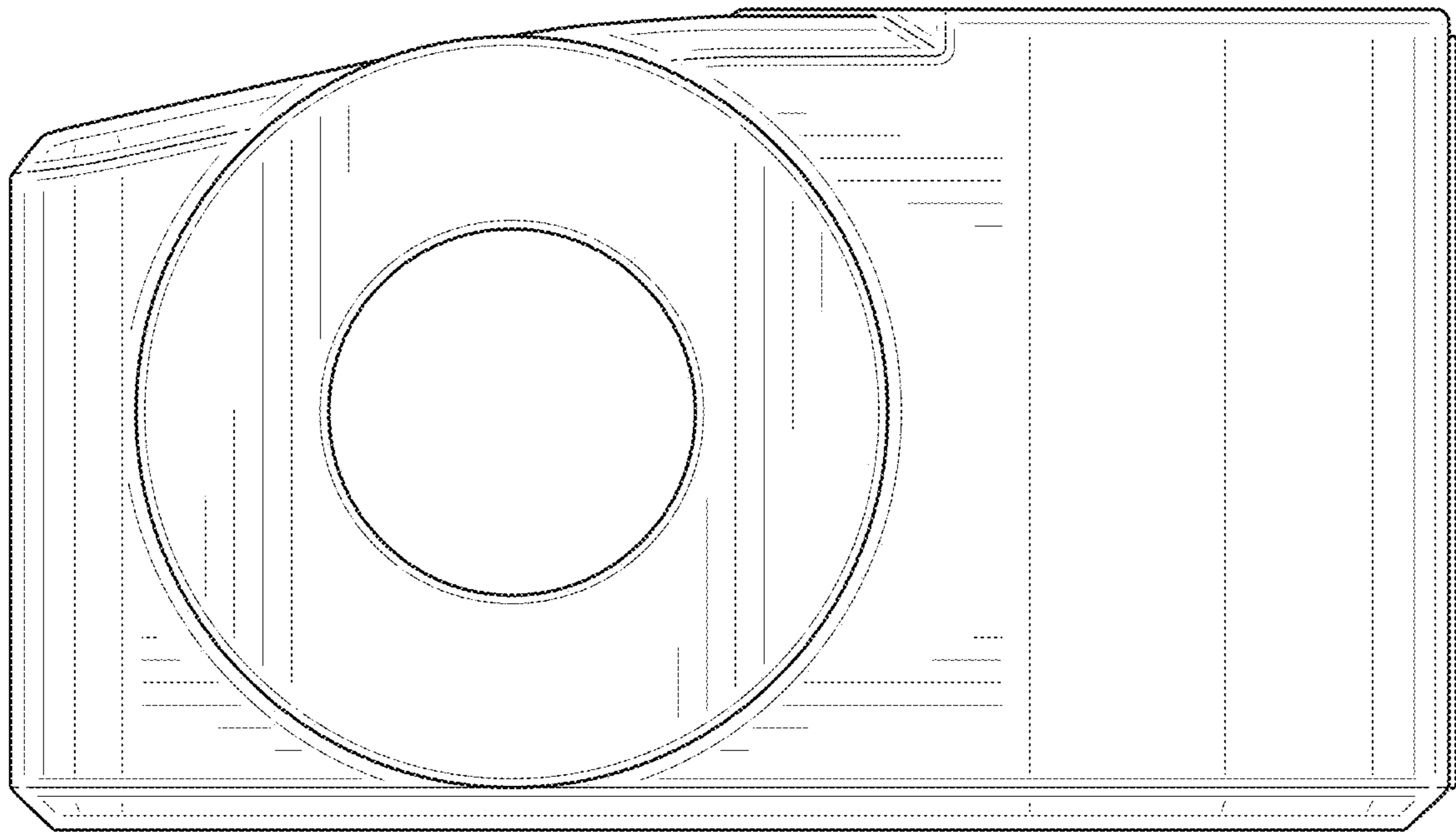
**FIG. 4**



**FIG. 5**



**FIG. 6**



**FIG. 7**