



US00D931762S

(12) **United States Design Patent**
Hasuike

(10) **Patent No.:** **US D931,762 S**
(45) **Date of Patent:** **** Sep. 28, 2021**

(54) **CYCLE VEHICLE**
(71) Applicant: **REV S.r.l.**, Milan (IT)
(72) Inventor: **Makio Hasuike**, Milan (IT)
(73) Assignee: **REV S.R.L.**, Milan (IT)
(**) Term: **15 Years**
(21) Appl. No.: **29/705,180**
(22) Filed: **Sep. 10, 2019**

6,053,518 A * 4/2000 Chiu B62K 27/003
280/204
6,056,306 A * 5/2000 Rust B62B 7/06
280/204
6,296,297 B1 * 10/2001 Barrow B60P 3/341
296/161
7,172,206 B2 * 2/2007 Staszak B62B 7/12
280/204
7,748,728 B2 * 7/2010 Dixon B62K 3/005
280/202
8,695,992 B2 * 4/2014 Piaget B62B 5/0079
280/1.5
8,801,322 B2 * 8/2014 Shalaby B62B 3/12
403/322.4

(Continued)

(30) **Foreign Application Priority Data**

Mar. 12, 2019 (EM) 006304622

(51) **LOC (13) Cl.** **12-11**

(52) **U.S. Cl.**
USPC **D12/112**

(58) **Field of Classification Search**
USPC D12/101, 102, 105, 111, 112, 117
CPC . B62K 9/00; B62K 9/02; B62K 27/12; B62K
27/16; B62K 27/003
See application file for complete search history.

(56) **References Cited**

U.S. PATENT DOCUMENTS

3,724,873 A * 4/1973 Glamb B62K 9/02
280/203
5,687,980 A * 11/1997 Eckroth B62K 27/16
280/204
5,785,333 A * 7/1998 Hinkston B62K 27/003
280/204
D400,476 S * 11/1998 Winchester D12/102
5,829,770 A * 11/1998 Chiu B62K 27/02
280/204
5,921,571 A * 7/1999 Bell B62K 27/02
280/204
5,979,921 A * 11/1999 Derven B62K 15/006
280/204

Primary Examiner — Darlington Ly

(74) *Attorney, Agent, or Firm* — Michael S. Hargis

(57) **CLAIM**

The ornamental design for a cycle vehicle, as shown and described.

DESCRIPTION

FIG. 1 is a front and right side perspective view of a cycle vehicle, embodying my new design;
FIG. 2 is a right side elevation view thereof;
FIG. 3 is a left side elevation view thereof;
FIG. 4 is a front elevation view thereof;
FIG. 5 is a rear elevation view thereof;
FIG. 6 is a bottom plan view thereof;
FIG. 7 is a top plan view thereof;
FIG. 8 is a top plan view thereof with the seat bench in an alternate configuration;
FIG. 9 is a top, rear, and left side perspective view thereof; and,
FIG. 10 is a top, rear, and left side perspective view thereof with the seat bench removed.
The broken lines in the drawings illustrate portions of the cycle vehicle that form no part of the claimed design.

1 Claim, 10 Drawing Sheets

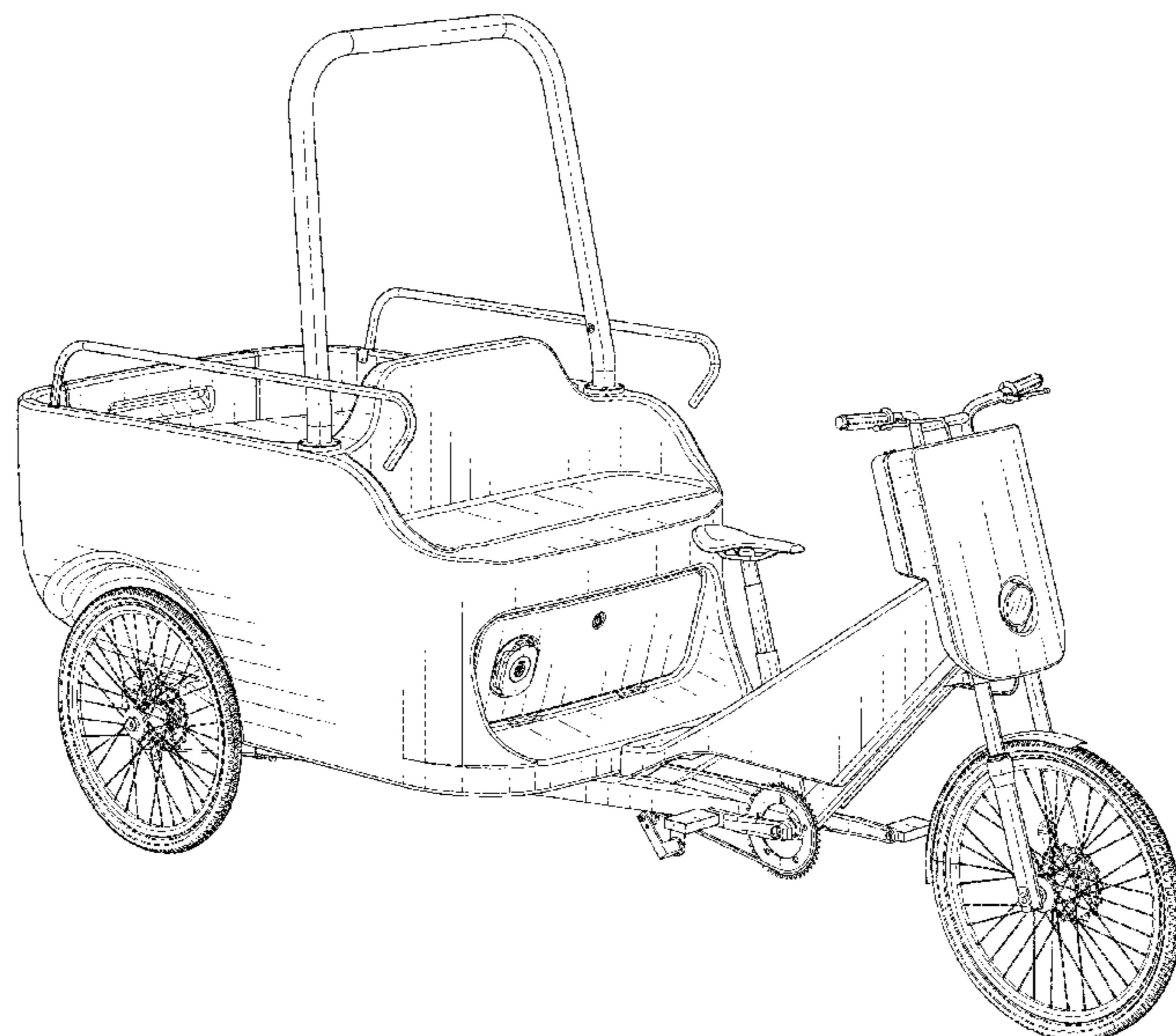

(56)

References Cited

U.S. PATENT DOCUMENTS

8,967,651 B1 * 3/2015 Simic B62K 27/02
280/204
D764,353 S * 8/2016 Lambert D12/101
D863,111 S * 10/2019 Kern D12/101
10,442,452 B2 * 10/2019 Fleming B62B 7/126
10,577,045 B2 * 3/2020 Walter B62K 21/00
D887,905 S * 6/2020 Fricke D12/114

* cited by examiner

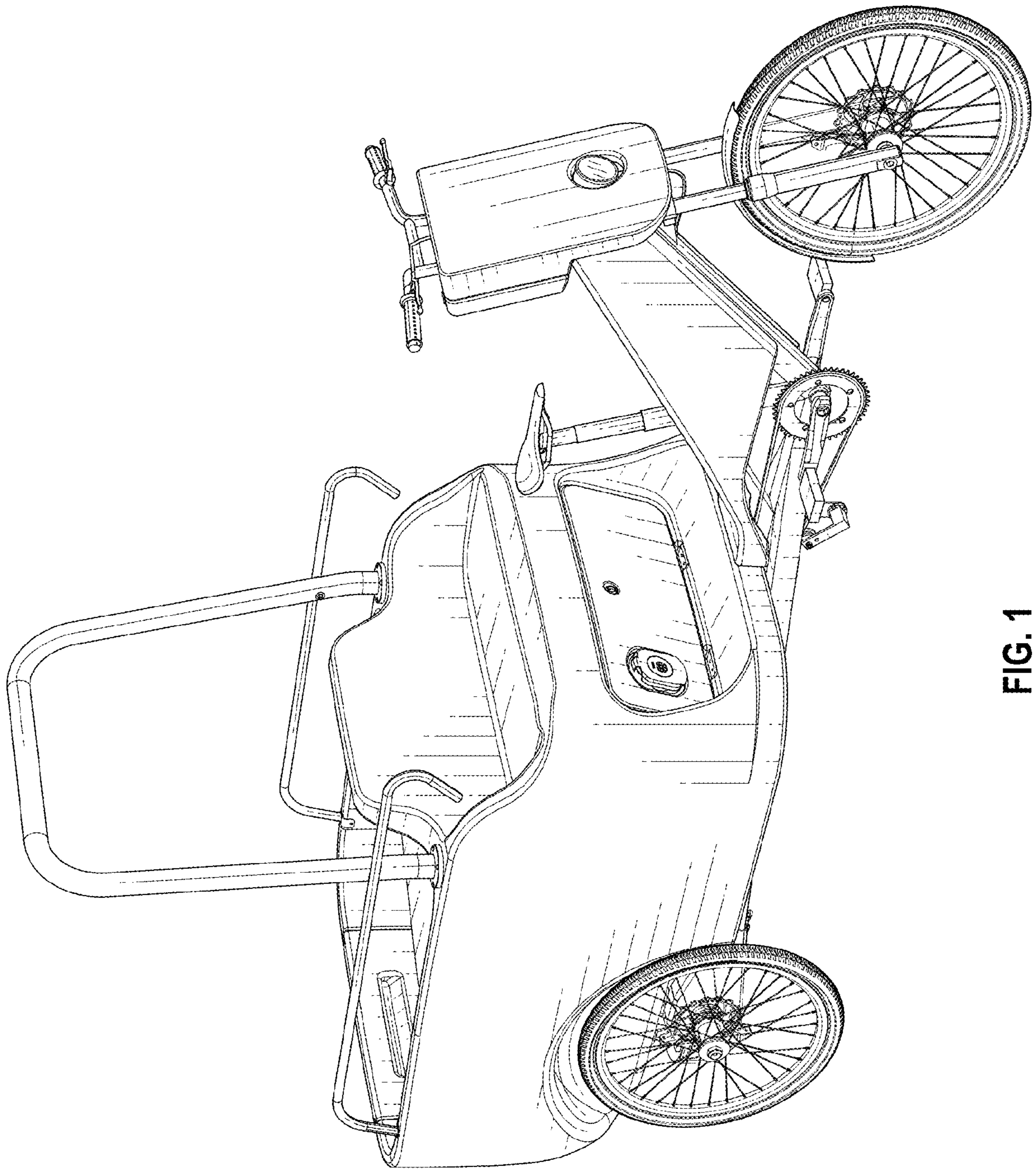

FIG. 1

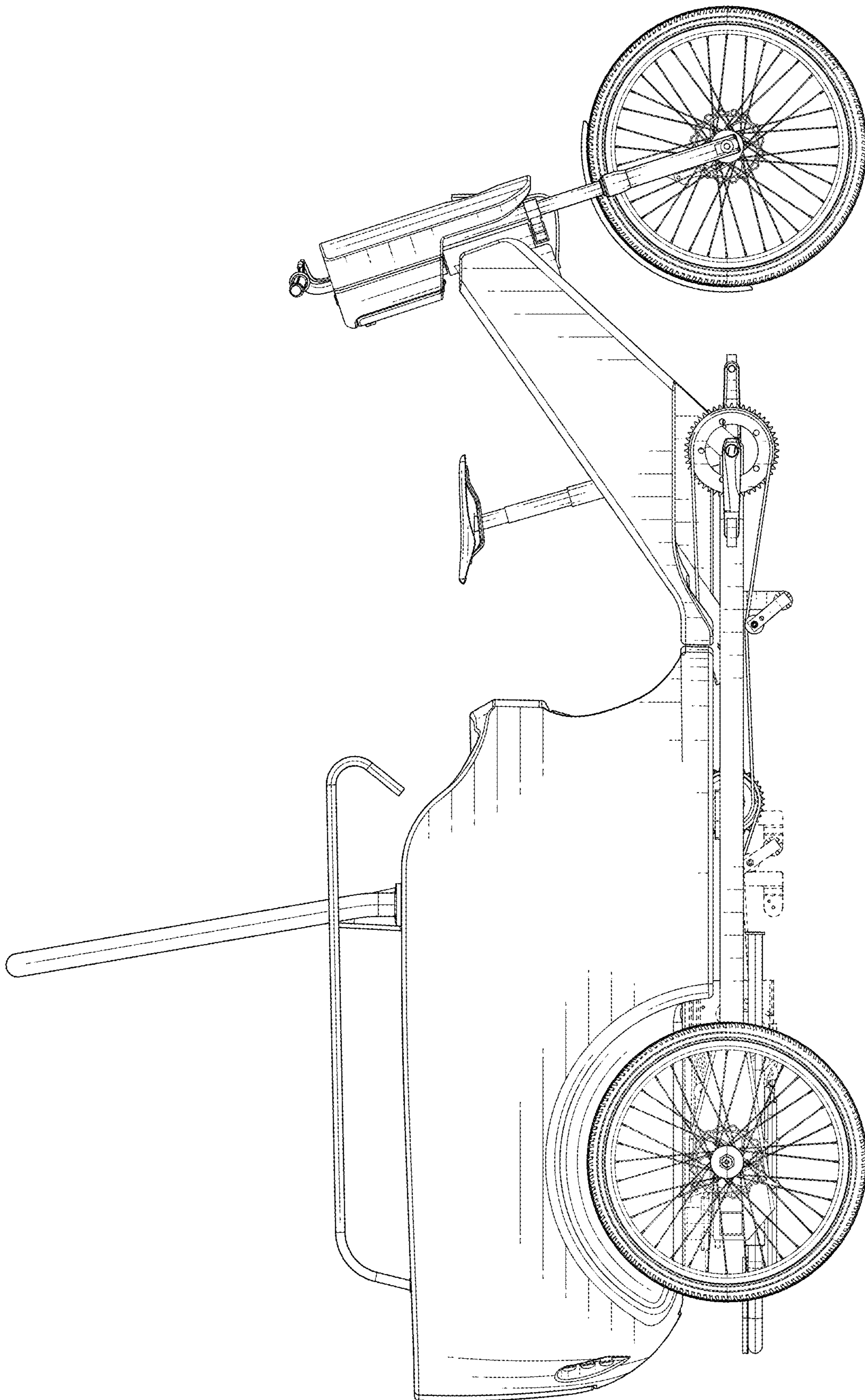

FIG. 2

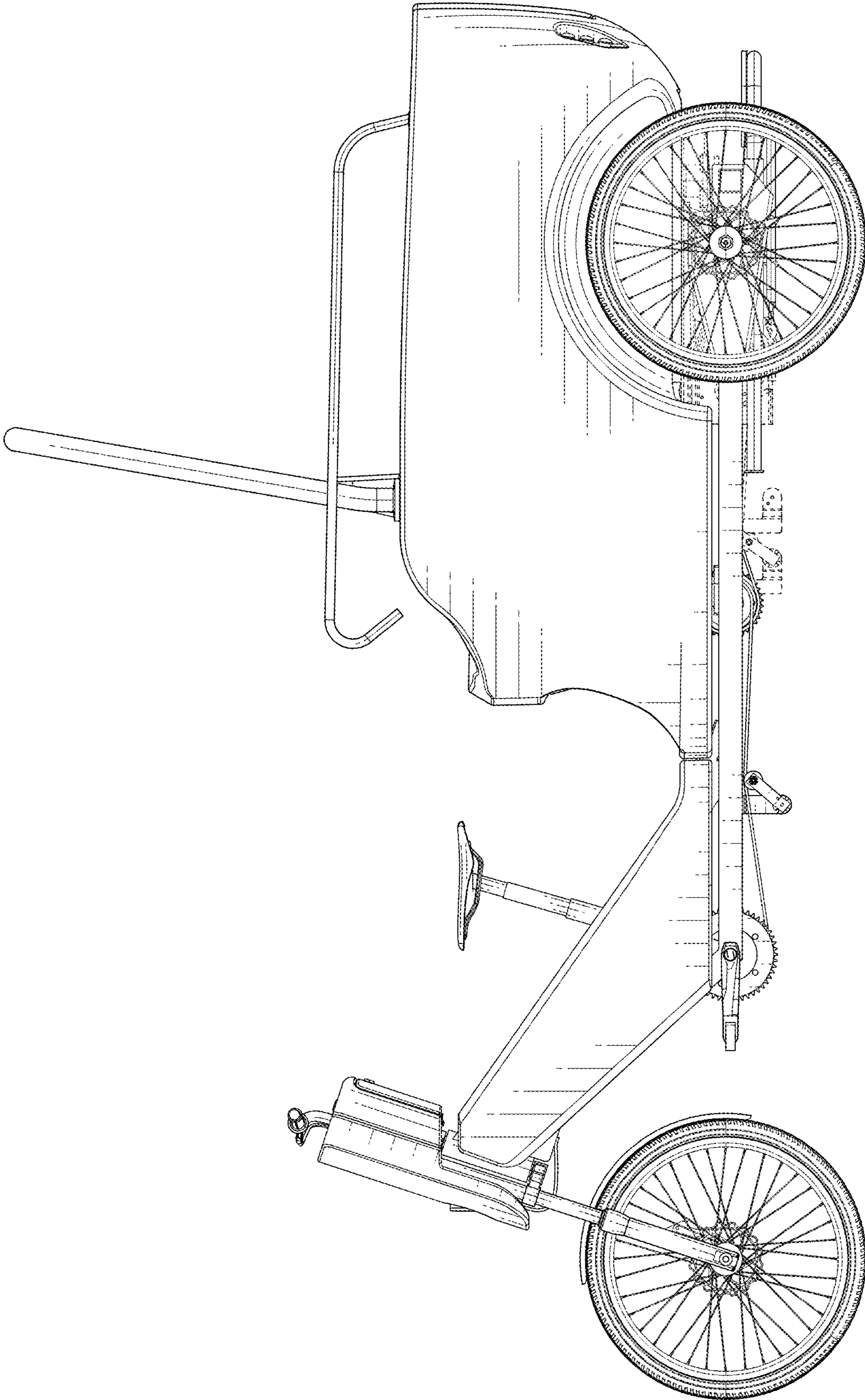

FIG. 3

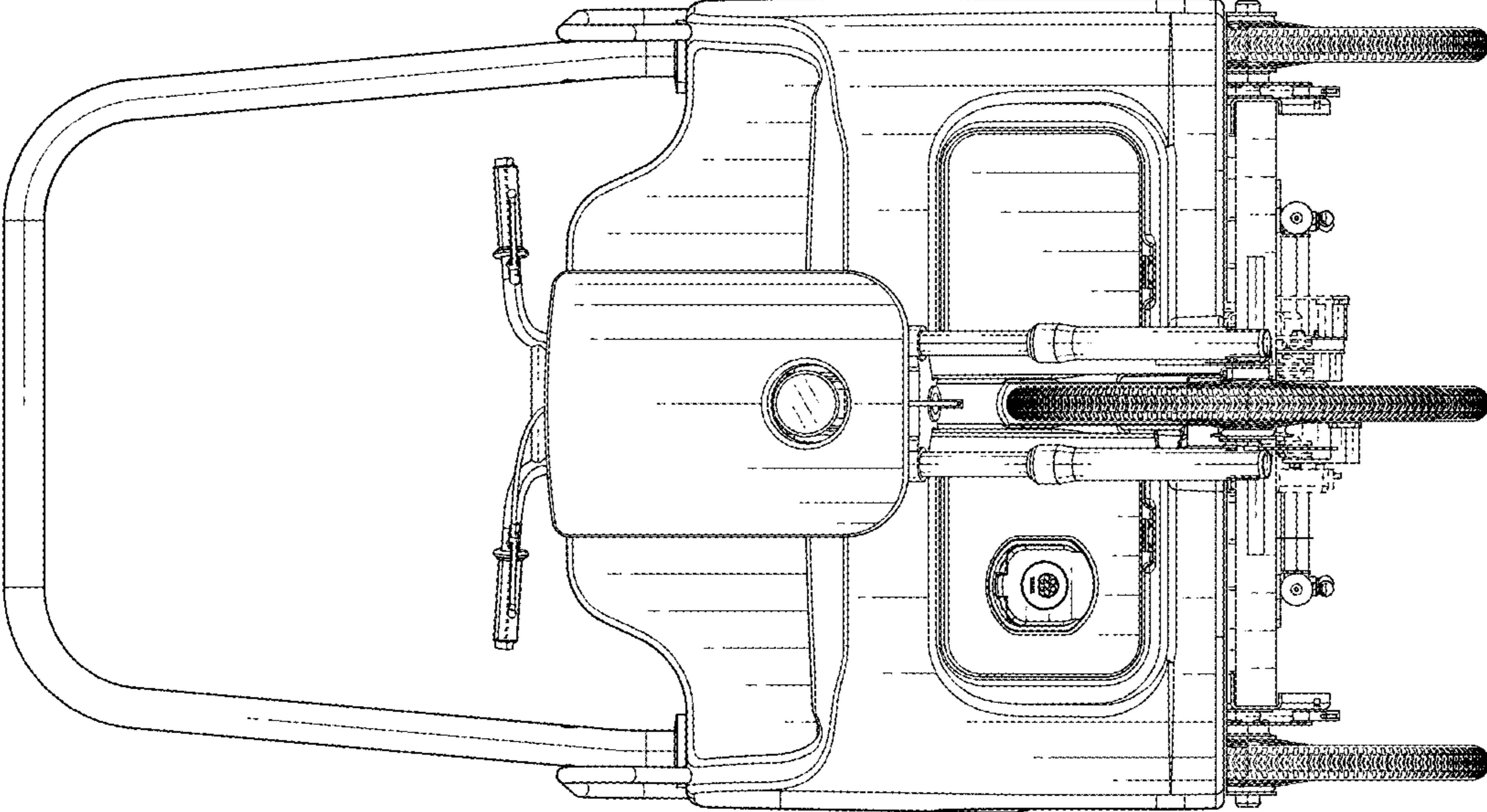

FIG. 4

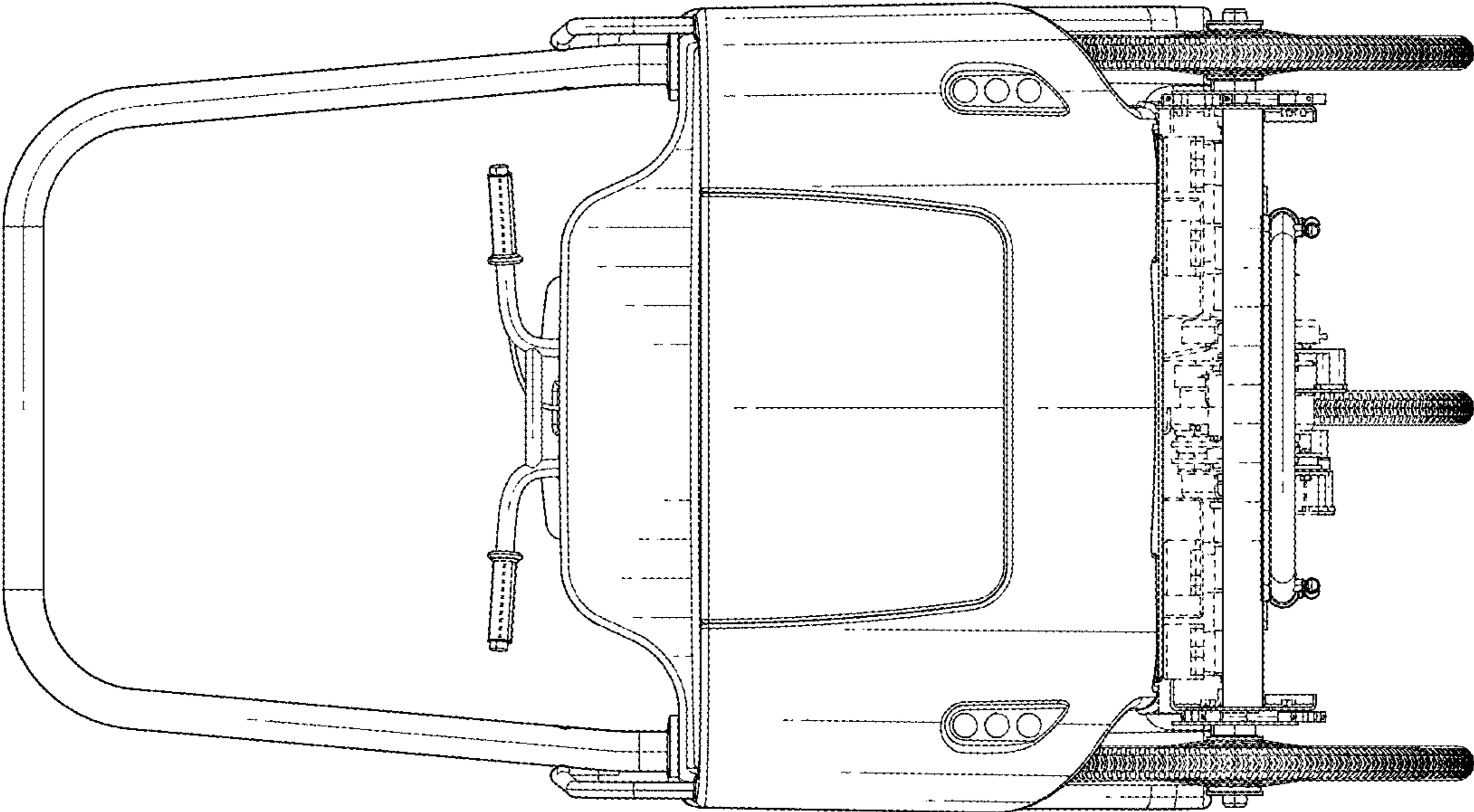

FIG. 5

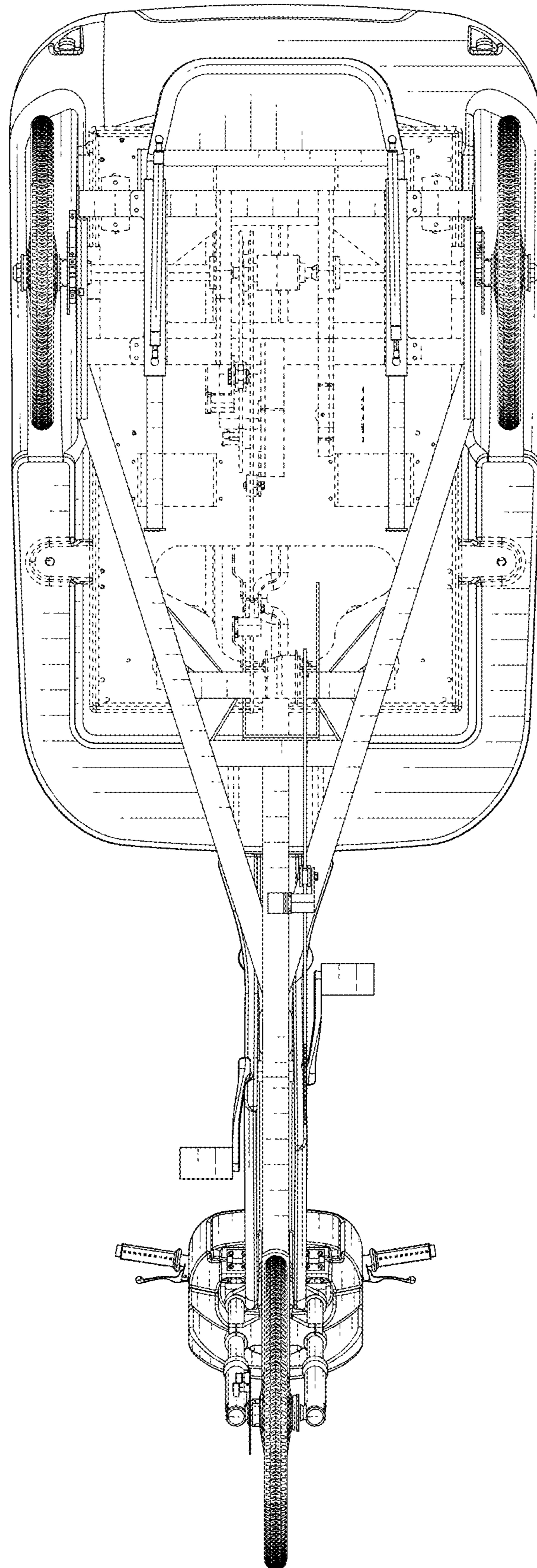

FIG. 6

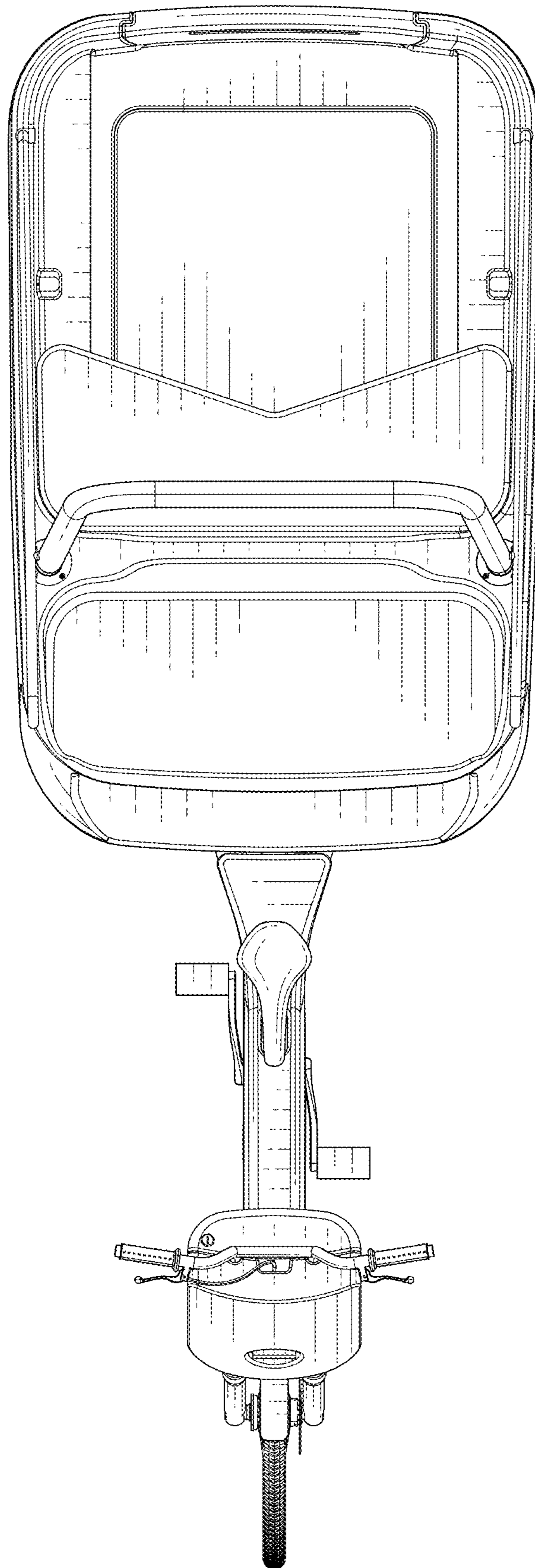

FIG. 7

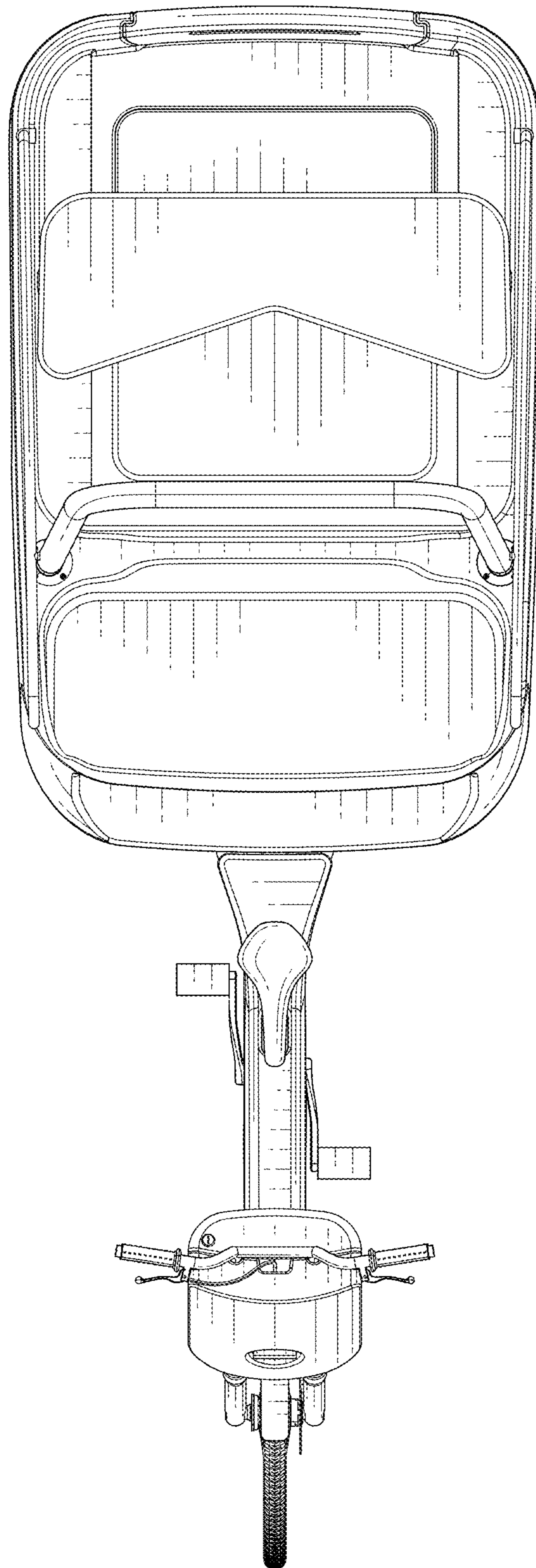

FIG. 8

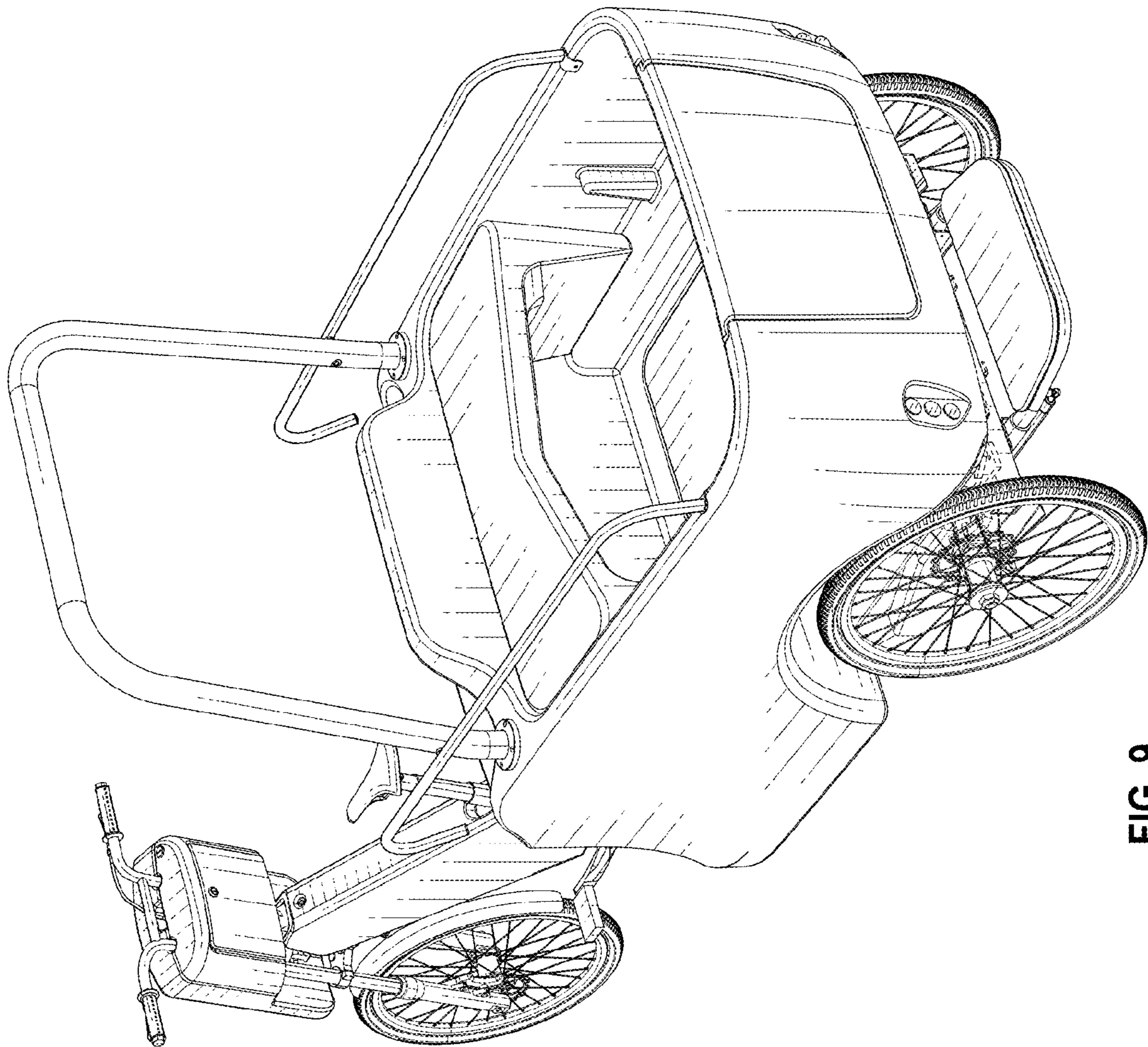

FIG. 9

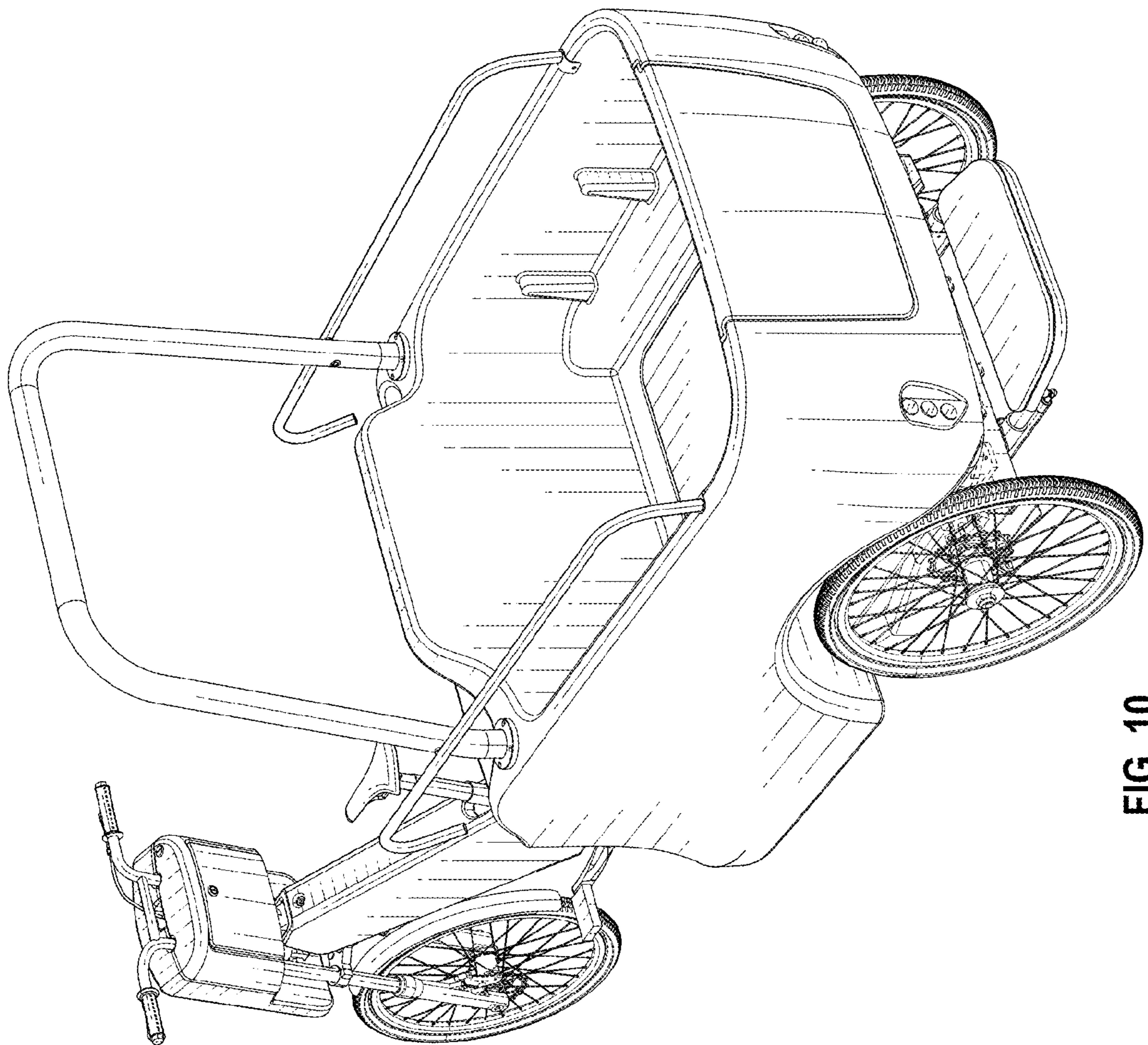

FIG. 10