



US00D931719S

(12) **United States Design Patent** (10) **Patent No.:** **US D931,719 S**
Hancock (45) **Date of Patent:** **** Sep. 28, 2021**

- (54) **COTTER PIN ASSIST DEVICE**
- (71) Applicant: **Truck Shields, LLC**, Salt Lake City, UT (US)
- (72) Inventor: **Dennis H Hancock**, Evanston, WY (US)
- (73) Assignee: **Truck Shields, LLC**, Salt Lake City, UT (US)
- (**) Term: **15 Years**
- (21) Appl. No.: **29/592,247**
- (22) Filed: **Jan. 27, 2017**

- 2,588,731 A * 3/1952 Kabanuck B67B 7/24 220/278
- 3,151,512 A 10/1964 Charczenko
- 3,256,579 A * 6/1966 Hoover F16G 11/105 24/134 R
- 3,728,775 A 4/1973 Hosbach
(Continued)

FOREIGN PATENT DOCUMENTS

- CN 302787205 * 4/2014 8/8
- DE 2710842 A1 9/1978
(Continued)

OTHER PUBLICATIONS

Amazon.com: Pin Wiz Trailer Hitch Clip, oldest review 2018, https://www.amazon.com/Pin-Wiz-Trailer-Hitch-Black/dp/B079QQ9PK5/ref=cm_cr_arp_d_product_top?ie=UTF8, site visited Aug. 17, 2018 (Year: 2018).*

(Continued)

Primary Examiner — John R Yeh
(74) *Attorney, Agent, or Firm* — TraskBritt

(57) **CLAIM**

The ornamental design for a cotter pin assist device, as shown and described.

DESCRIPTION

FIG. 1 is a side perspective view of the cotter pin assist device showing my new design;
 FIG. 2 is a bottom view thereof;
 FIG. 3 is a side view thereof;
 FIG. 4 is another side view thereof;
 FIG. 5 is a top view thereof;
 FIG. 6 is an end view thereof; and,
 FIG. 7 is another end view thereof.
 The broken lines in the figures illustrate environment of the cotter pin assist device and form no part of the claimed design.

1 Claim, 4 Drawing Sheets

Related U.S. Application Data

- (60) Provisional application No. 62/344,902, filed on Jun. 2, 2016.
- (51) **LOC (13) Cl.** **08-08**
- (52) **U.S. Cl.**
USPC **D8/395**
- (58) **Field of Classification Search**
USPC ... D8/33-34, 40-41, 347-348, 18, 395-396;
D32/46, 33, 40; D23/265
CPC ... B67B 7/40; B67B 7/00; F16B 21/00; F16B 21/12; B60D 1/36
See application file for complete search history.

References Cited

U.S. PATENT DOCUMENTS

- 872,180 A 11/1907 Hite
- 1,280,756 A 10/1918 Kelecom
- 1,429,353 A * 9/1922 Karsky F16B 21/12 16/383
- 1,849,605 A * 3/1932 Whitlock F16B 21/125 411/514
- 2,166,614 A 7/1939 Strid
- D118,329 S * 12/1939 Crowley D3/210
- 2,400,960 A 5/1946 Strid

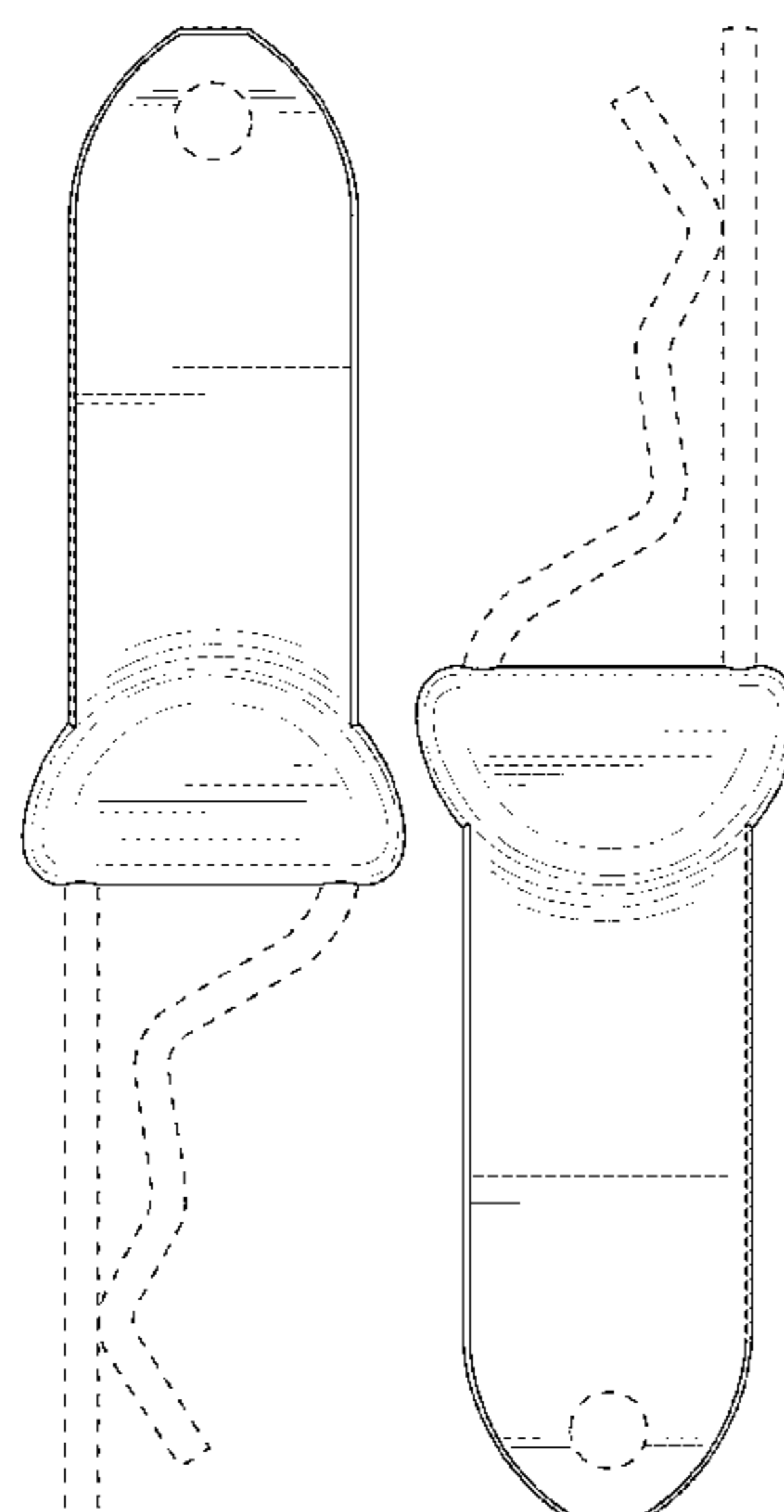

(56)

References Cited

U.S. PATENT DOCUMENTS

D241,806 S 10/1976 Johnson
 4,037,513 A * 7/1977 Hobson F16B 21/12
 24/555
 4,087,112 A 5/1978 Lee, Jr.
 4,172,523 A 10/1979 Weglage
 D255,983 S * 7/1980 Armstrong D8/382
 4,298,212 A 11/1981 Jamison
 4,412,464 A * 11/1983 Cook B67B 7/403
 7/151
 D276,787 S * 12/1984 Burns D8/18
 D278,203 S * 4/1985 Braukmann 81/3.55
 D278,436 S 4/1985 Storlie
 4,526,396 A 7/1985 Mayer
 4,541,311 A 9/1985 Trammell, Jr.
 D281,389 S * 11/1985 Summers D8/40
 4,553,737 A 11/1985 Yi
 4,555,125 A 11/1985 Goodlove
 4,624,619 A 11/1986 Uher
 4,773,805 A 9/1988 Krahling
 4,840,528 A 6/1989 Doom
 4,890,854 A 1/1990 Hoover
 D306,144 S 2/1990 Haggstrom
 D308,620 S * 6/1990 Baca D8/18
 D318,406 S * 7/1991 Gabriele D8/18
 D320,542 S 10/1991 McCord, Jr.
 5,267,494 A * 12/1993 Waluda E05B 19/00
 81/3.09
 D352,647 S * 11/1994 Stevens 248/499
 D356,763 S 3/1995 Herrick
 5,509,380 A * 4/1996 Tipp B67B 7/403
 81/3.55
 5,524,511 A 6/1996 Taka
 5,557,832 A 9/1996 Vanden Brook
 5,662,446 A 9/1997 Haan
 D386,056 S 11/1997 Streeter
 D389,624 S * 1/1998 Drimmie D3/210
 D396,885 S * 8/1998 Shyu D19/65
 D401,969 S * 12/1998 Ho D19/65
 D405,019 S 2/1999 Neuman
 5,979,015 A 11/1999 Tamaribuchi
 6,145,866 A 11/2000 Peter
 D480,283 S 10/2003 Brown
 D497,576 S 10/2004 Wang
 D515,411 S * 2/2006 Karl D8/395
 D519,024 S * 4/2006 Knight D8/395
 D535,181 S * 1/2007 Roychowdhury D8/394
 7,306,275 B2 12/2007 Kalous
 D560,565 S 1/2008 Kalous
 D570,257 S 6/2008 Vanderburgh et al.
 7,644,485 B2 1/2010 Muller et al.
 D620,785 S * 8/2010 St. Germaine D8/395

D641,615 S * 7/2011 Lin D8/394
 8,267,420 B2 9/2012 Merten et al.
 8,388,366 B2 3/2013 Yang
 D693,660 S * 11/2013 Hackett D8/18
 8,677,574 B1 3/2014 Thiessen et al.
 D713,709 S 9/2014 Goldman et al.
 D714,631 S * 10/2014 Frydlewski D8/394
 D716,138 S * 10/2014 Szymanski D8/395
 8,873,921 B2 10/2014 Lee et al.
 D724,914 S * 3/2015 Tipp D8/40
 9,090,136 B2 7/2015 Breeden et al.
 9,151,907 B2 10/2015 Jiang et al.
 D749,994 S 2/2016 Verboeket
 D771,483 S * 11/2016 Bonno D8/394
 9,669,276 B1 6/2017 Maloy
 D797,009 S 9/2017 Verboeket
 D810,517 S 2/2018 Singer
 D883,379 S * 5/2020 Lorenzo D19/99
 10,906,368 B2 * 2/2021 Hancock B60D 1/58
 2005/0262677 A1 12/2005 Tanaka et al.
 2006/0078374 A1 4/2006 Wrase et al.
 2006/0147297 A1 7/2006 Wrase et al.
 2007/0007782 A1 1/2007 Kalous
 2007/0062006 A1 3/2007 Wright, Jr.
 2007/0251059 A1 11/2007 You
 2009/0044847 A1 2/2009 Barangan
 2009/0278334 A1 11/2009 Carr et al.
 2010/0200333 A1 8/2010 Maurice et al.
 2013/0171864 A1 7/2013 Farris-Gilbert et al.
 2013/0205557 A1 8/2013 MacArthur et al.
 2014/0331464 A1 11/2014 Jiang et al.
 2017/0348838 A1 12/2017 Hancock
 2018/0015797 A1 * 1/2018 Hancock B60D 1/02
 2018/0147715 A1 5/2018 Promo et al.

FOREIGN PATENT DOCUMENTS

JP 4546949 B2 9/2010
 JP 5220149 B2 6/2013

OTHER PUBLICATIONS

Cotter hair pin Details—175-2106—USA-CLEAN, website 2018, site visited Aug. 17, 2018, https://usafix.usaclean.com/...m=adwords&gclid=Cj0KCQjw5NnbBRDaARIsAJP-YR_UW77sZTQUF2JSm9Pxxk0aDakvv9H-ZPFomLCCZULNJK-G3rR91UaAsZxEALw_wcB (Year: 2018).
 Durometer Shore Hardness Scale for Rubbers.
 Suregrip (Trademark) L-Handle Hitch Pin Lock Found at: https://www.reese-hitches.com/products/Suregrip_tradeChrome, 3015-049 (Year: 2019).

* cited by examiner

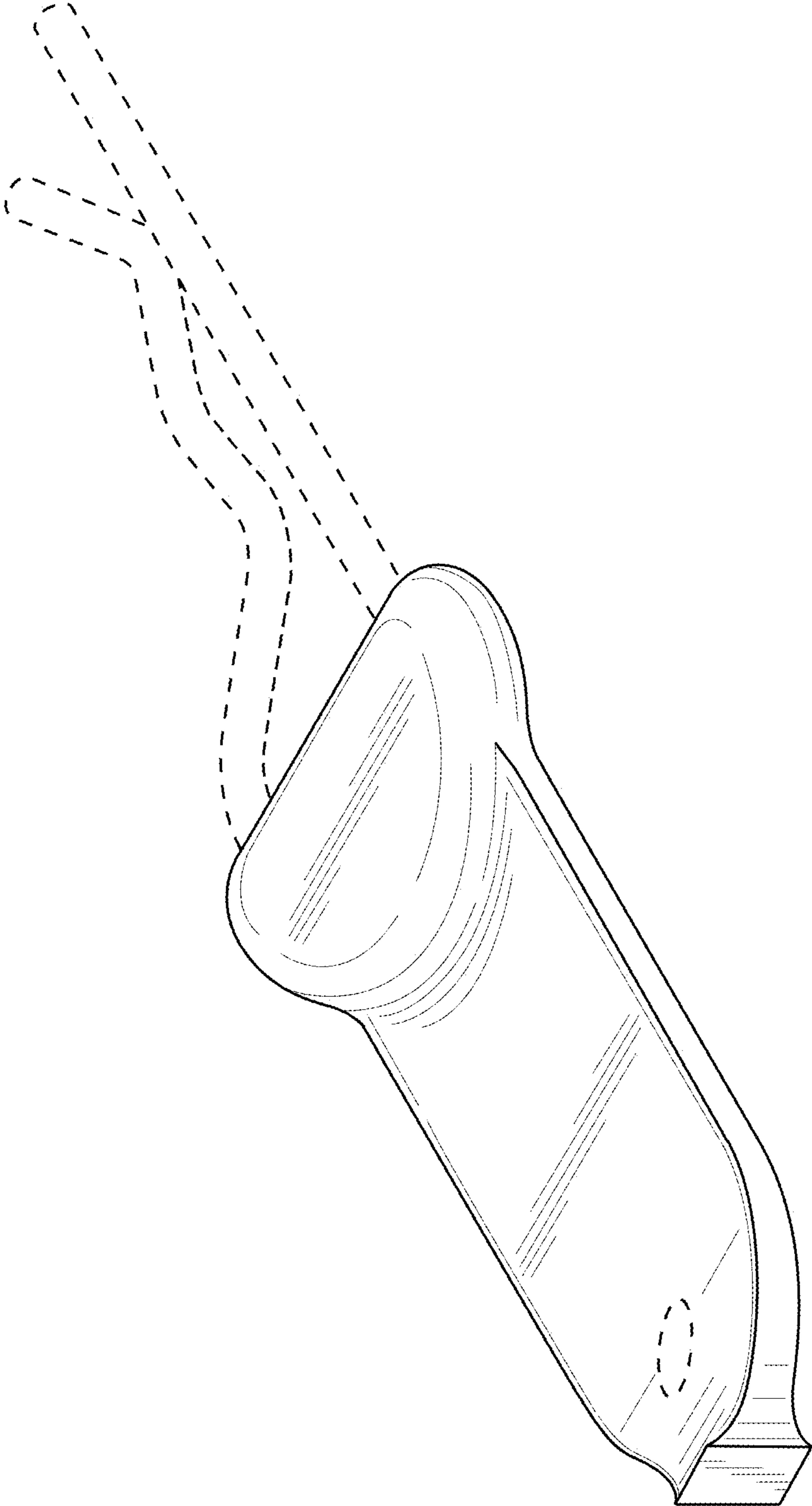

FIG. 1

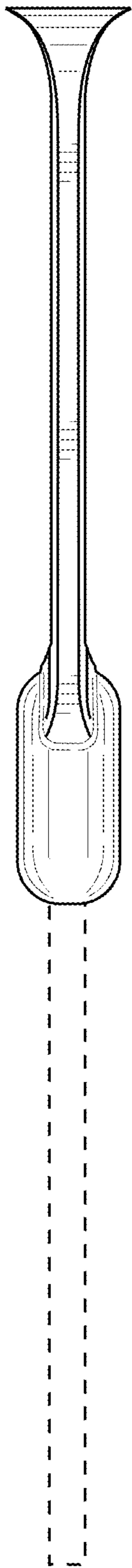

FIG. 2

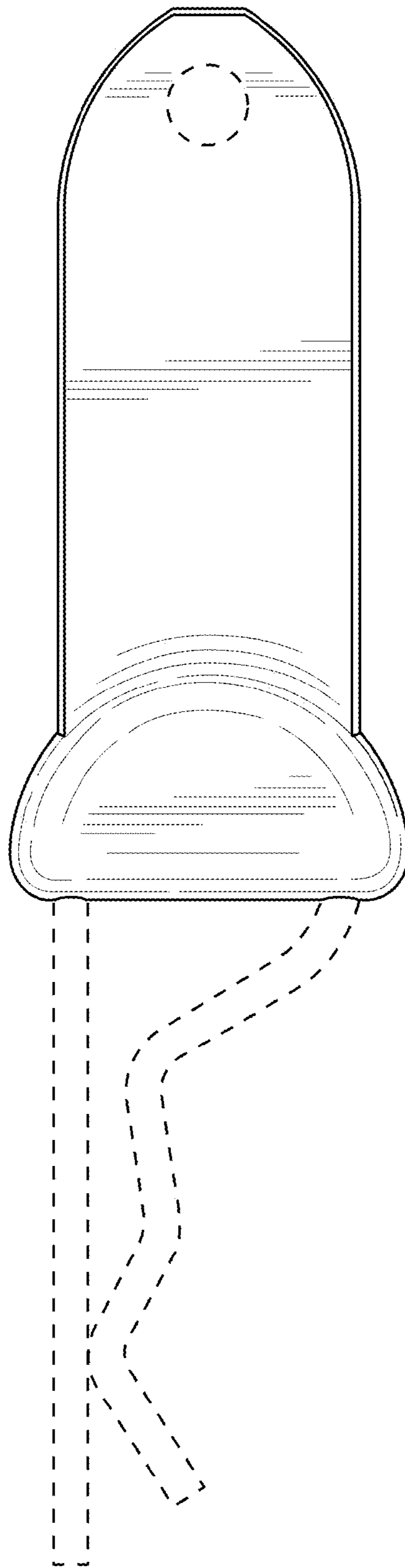

FIG. 3

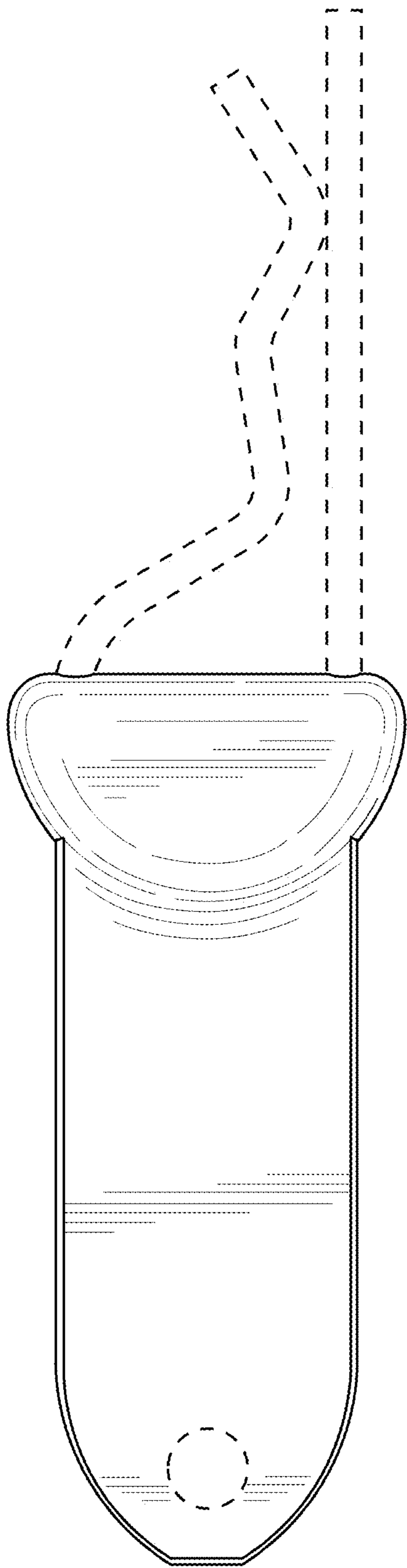

FIG. 4

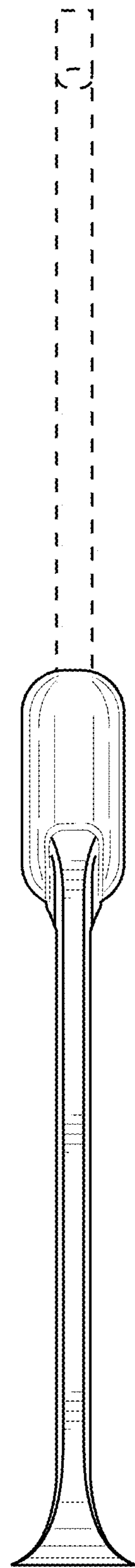

FIG. 5

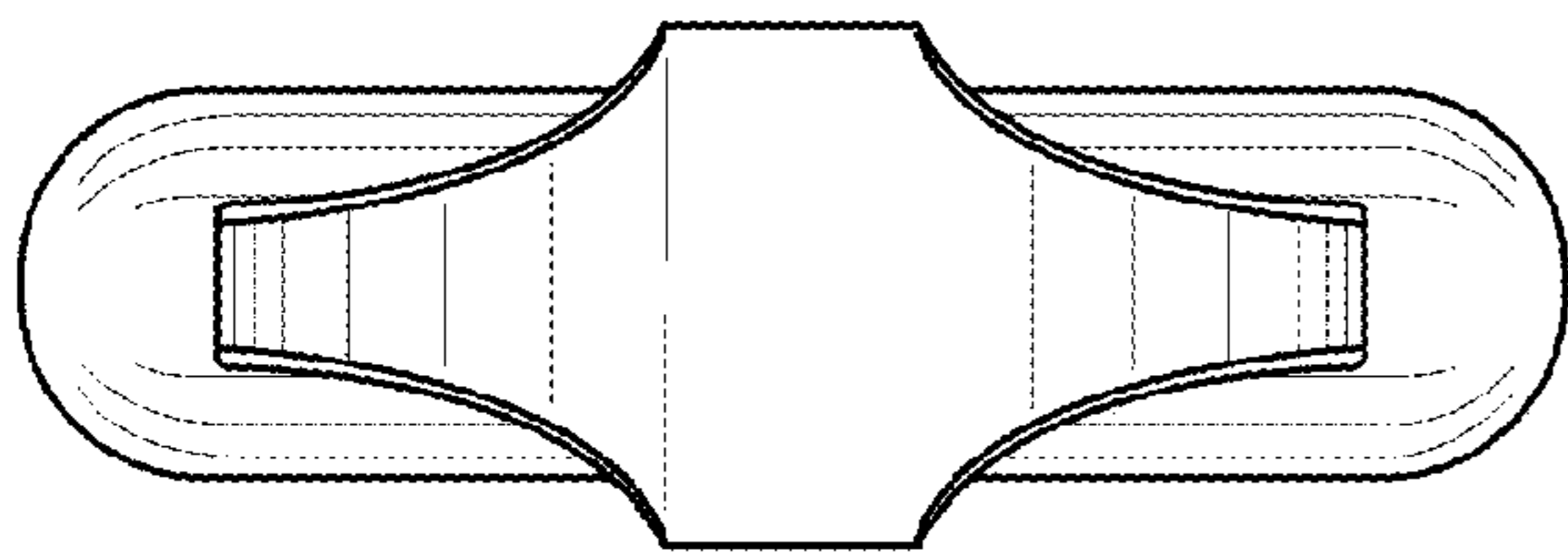

FIG. 6

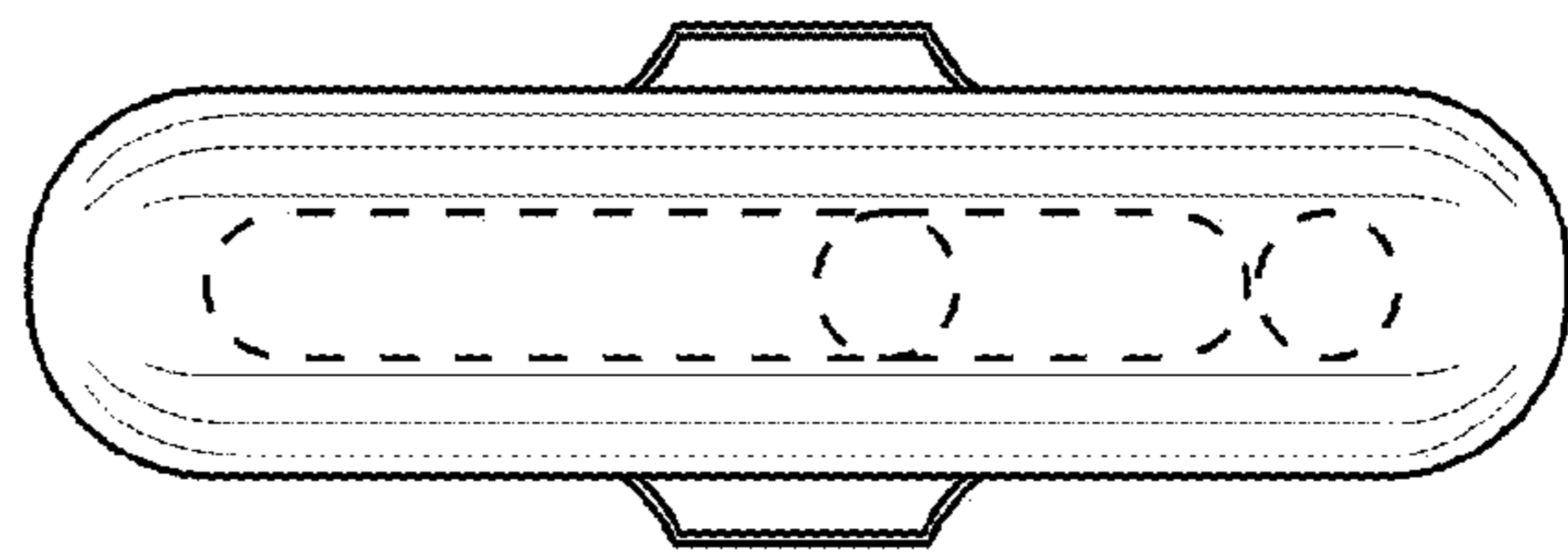

FIG. 7