



US00D931278S

(12) **United States Design Patent**
Pombo et al.

(10) **Patent No.:** **US D931,278 S**
(45) **Date of Patent:** **** Sep. 21, 2021**

(54) **HEADSET**

(71) Applicant: **RealWear, Inc.**, Vancouver, WA (US)

(72) Inventors: **Stephen A. Pombo**, Campbell, CA (US); **Nima Lahijani Shams**, San Jose, CA (US); **George Henry Hines**, San Francisco, CA (US); **Sanjay Subir Jhawar**, Menlo Park, CA (US)

(73) Assignee: **REALWEAR, INC.**, Vancouver, WA (US)

(**) Term: **15 Years**

(21) Appl. No.: **29/700,887**

(22) Filed: **Aug. 6, 2019**

(51) **LOC (13) Cl.** **14-02**

(52) **U.S. Cl.**
USPC **D14/372**

(58) **Field of Classification Search**
USPC D14/372, 496, 432, 371, 125, 126, 129, D14/299; D16/300-342; 351/158, 153, 351/144; 345/7-9, 905; 455/344; 348/115, 53, 121, 739
CPC G02B 27/017; G02B 27/0158; G02B 27/0161; G02B 27/0181; G02B 27/0185; G02B 27/0189

See application file for complete search history.

(56) **References Cited**

U.S. PATENT DOCUMENTS

D836,633 S * 12/2018 Natsume D14/372
D841,647 S * 2/2019 Sakai D14/372

D850,445 S * 6/2019 Porter D14/372
D859,402 S * 9/2019 Eroma D14/372
D863,299 S * 10/2019 Jacobsen D14/372
D881,879 S * 4/2020 Keller D14/372
D904,402 S * 12/2020 Marquis D14/372
D904,488 S * 12/2020 Kawa D16/208
D905,055 S * 12/2020 Shao D14/372
D914,019 S * 3/2021 Gao D14/372

* cited by examiner

Primary Examiner — Austin Murphy

(74) *Attorney, Agent, or Firm* — Shook, Hardy & Bacon L.L.P.

(57) **CLAIM**

The ornamental design for a headset, as shown and described.

DESCRIPTION

FIG. 1 is a left side view of a headset showing our design according to a first embodiment; FIG. 2 is a right side view thereof; FIG. 3 is a front view thereof; FIG. 4 is a back view thereof; FIG. 5 is a top view thereof; FIG. 6 is a bottom view thereof; FIG. 7 is a front right perspective view thereof; FIG. 8 is a back right perspective view thereof; FIG. 9 is a back left perspective view thereof; and, FIG. 10 is a front left perspective view thereof. The even-length broken lines are directed to environment, represent unclaimed subject matter, and form no part of the claimed design.

1 Claim, 9 Drawing Sheets

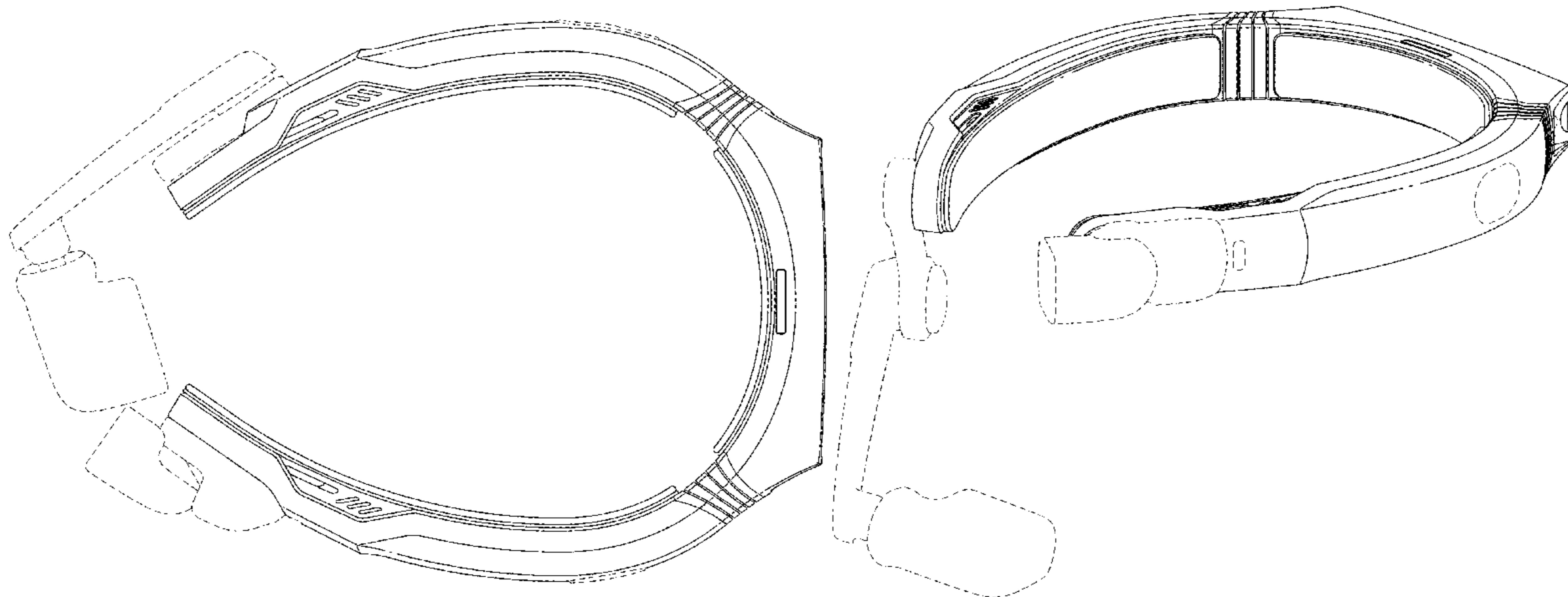

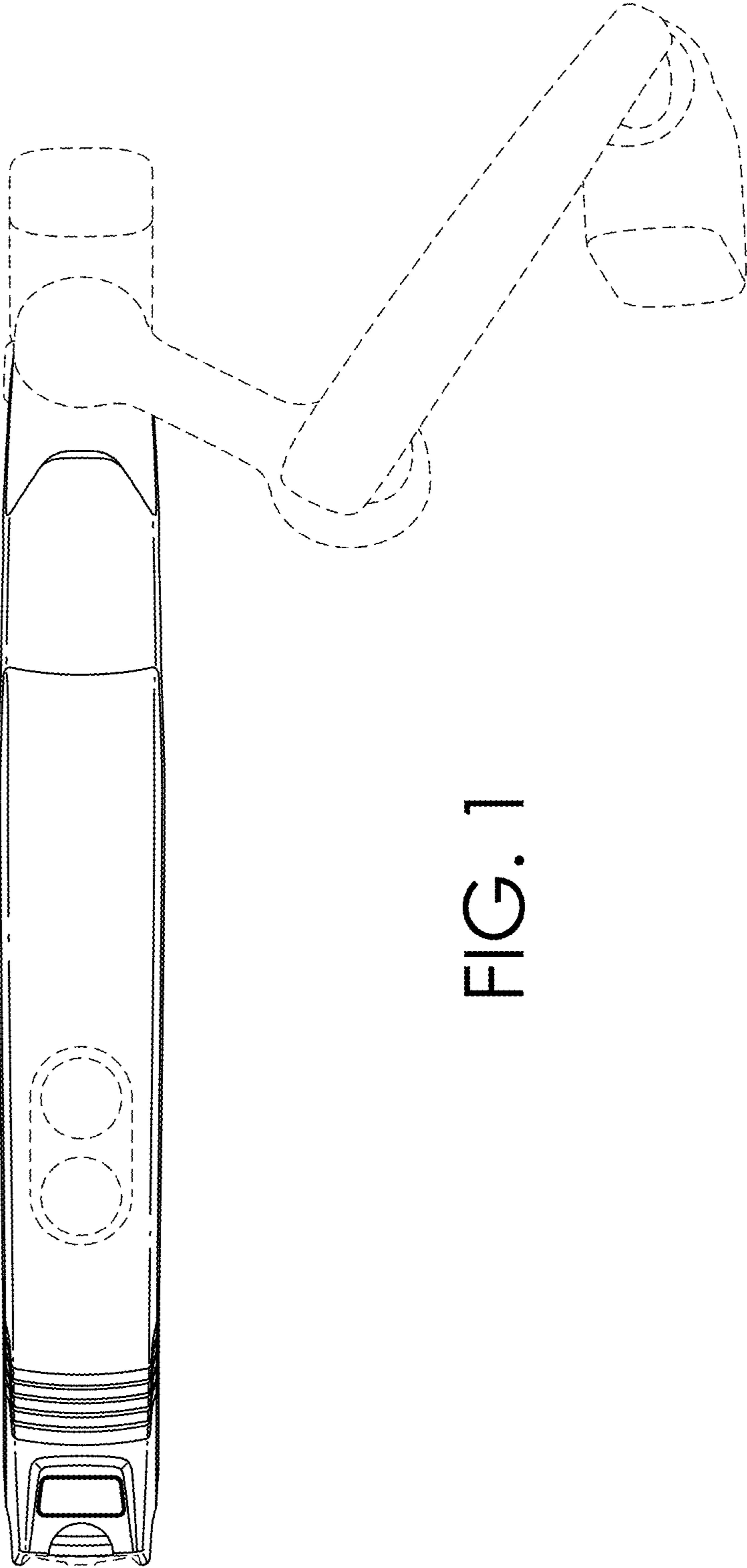

FIG. 1

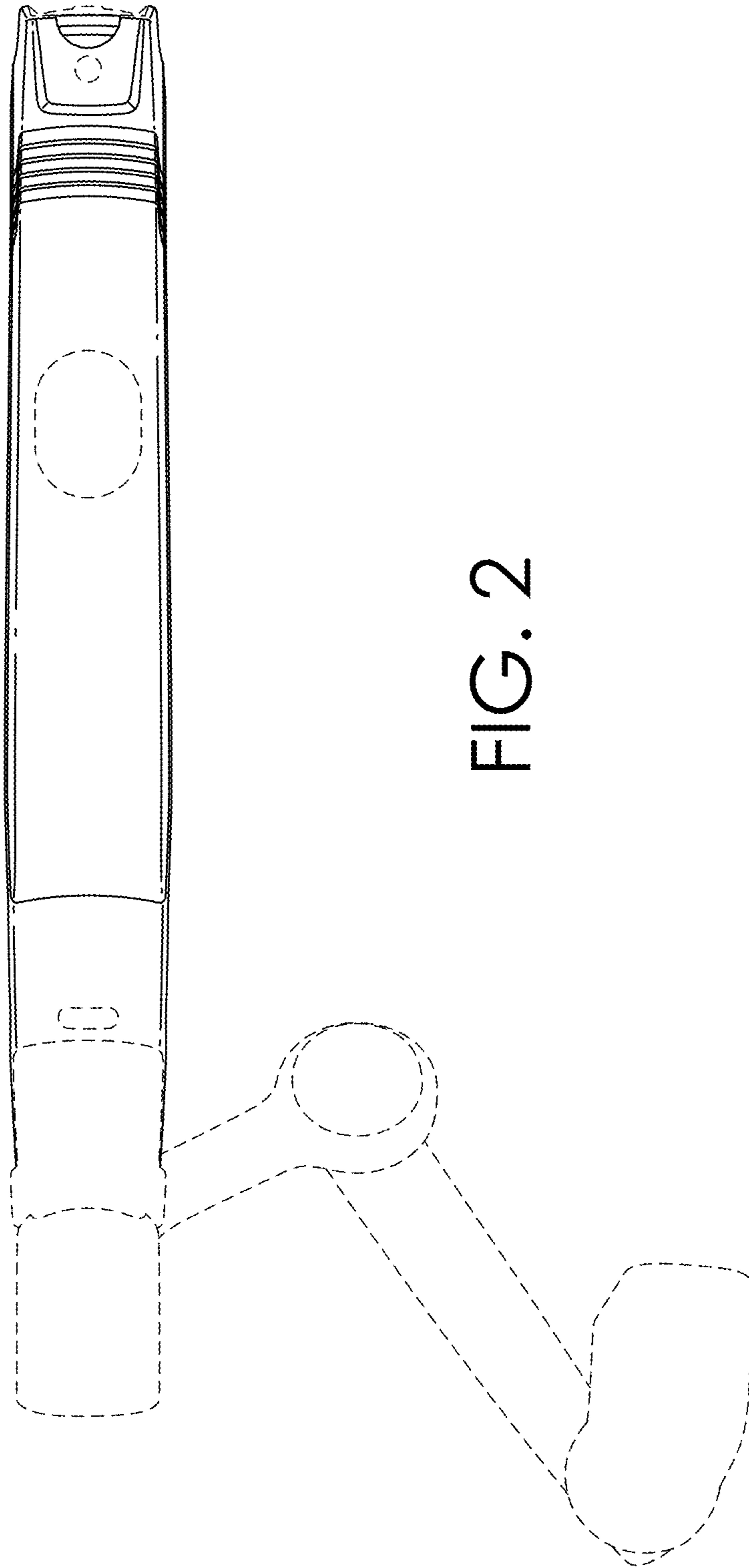

FIG. 2

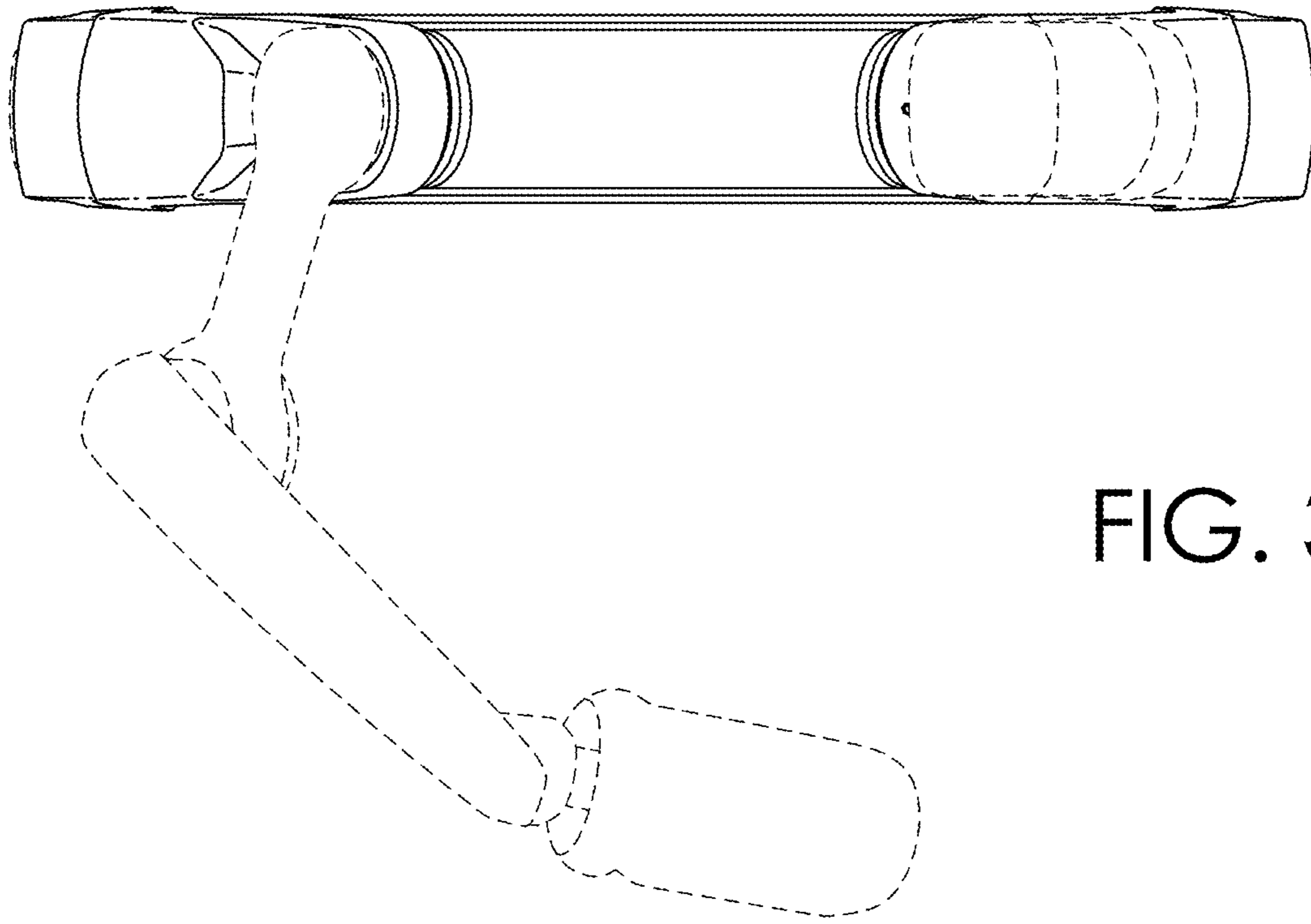

FIG. 3

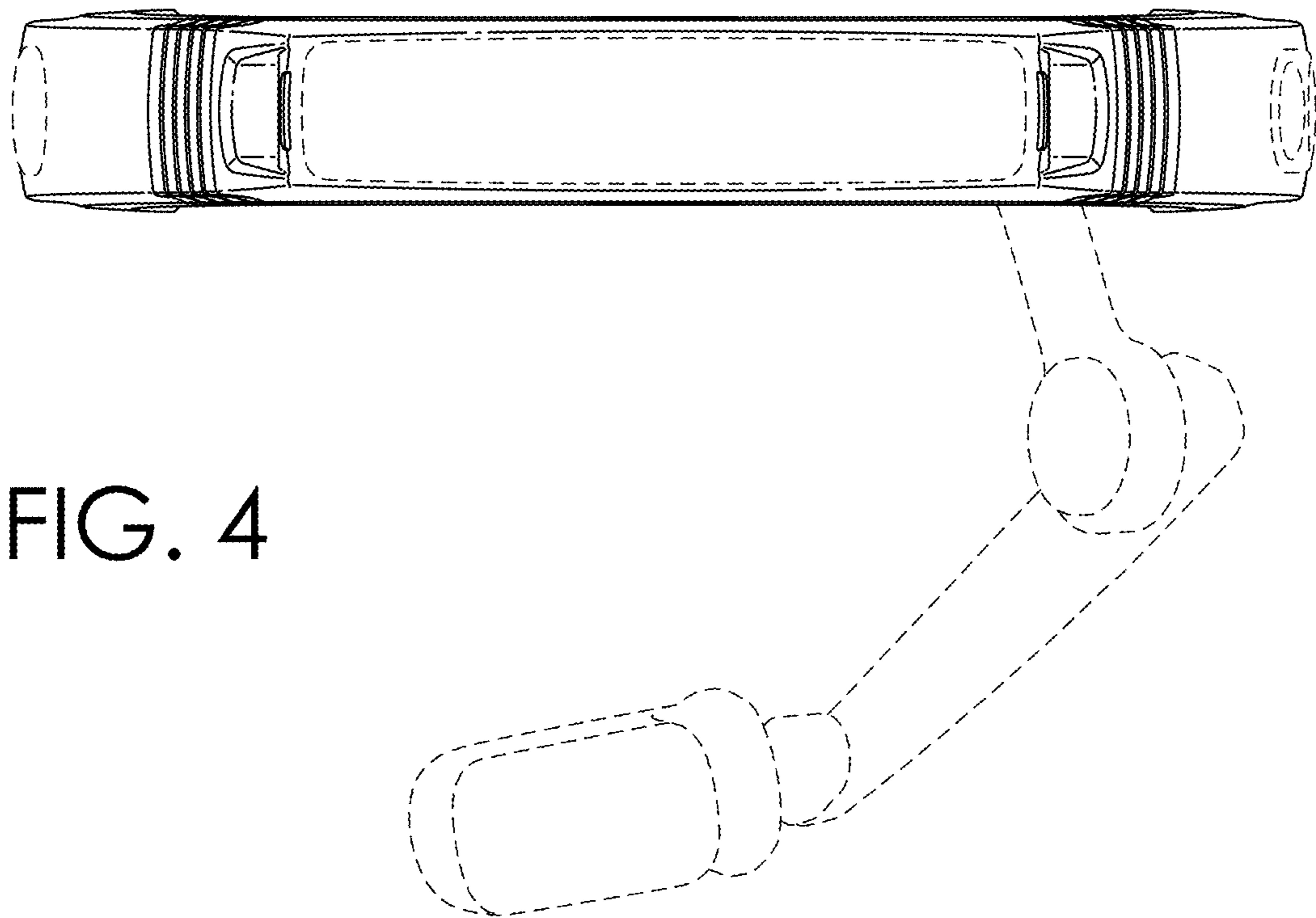

FIG. 4

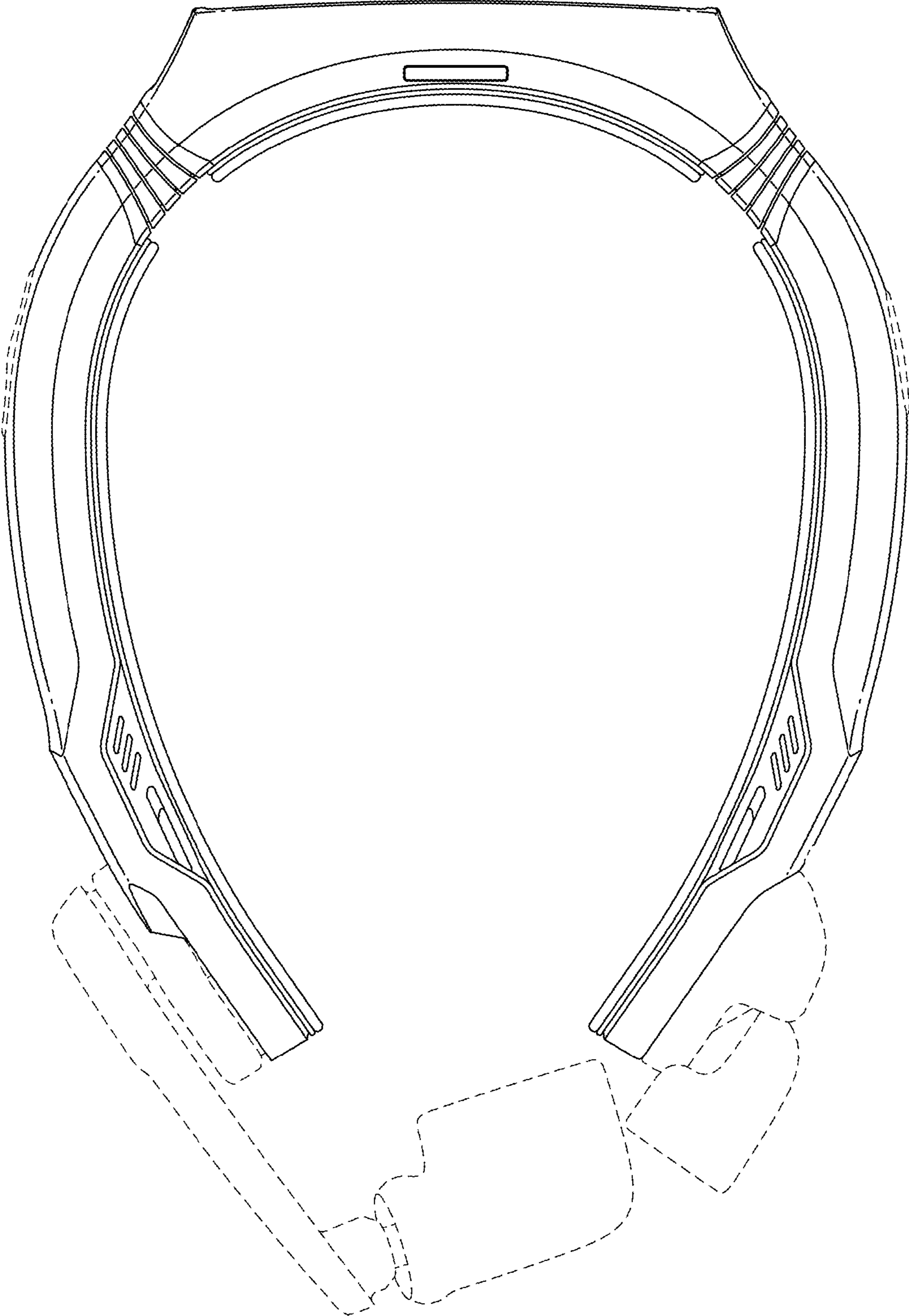

FIG. 5

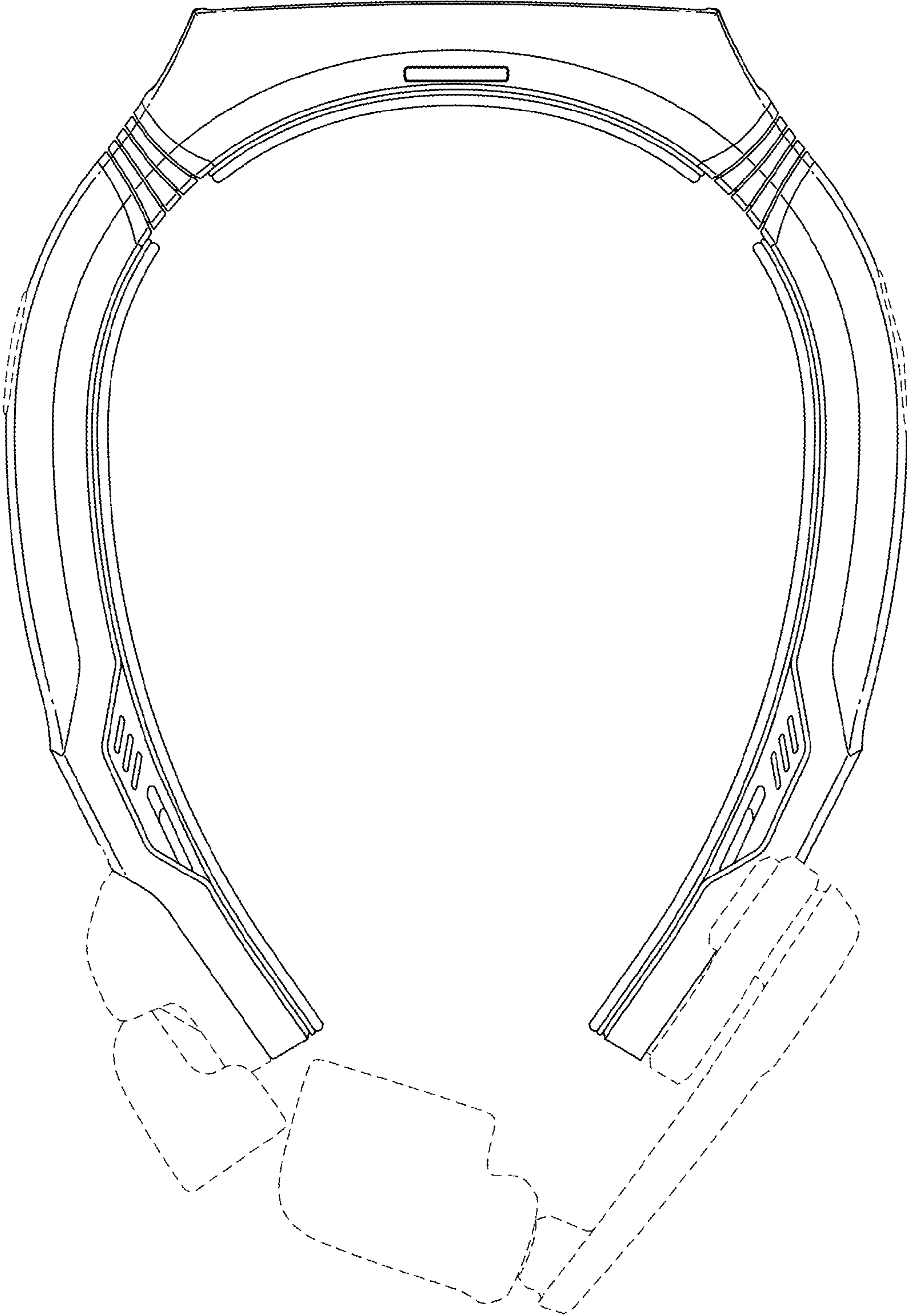

FIG. 6

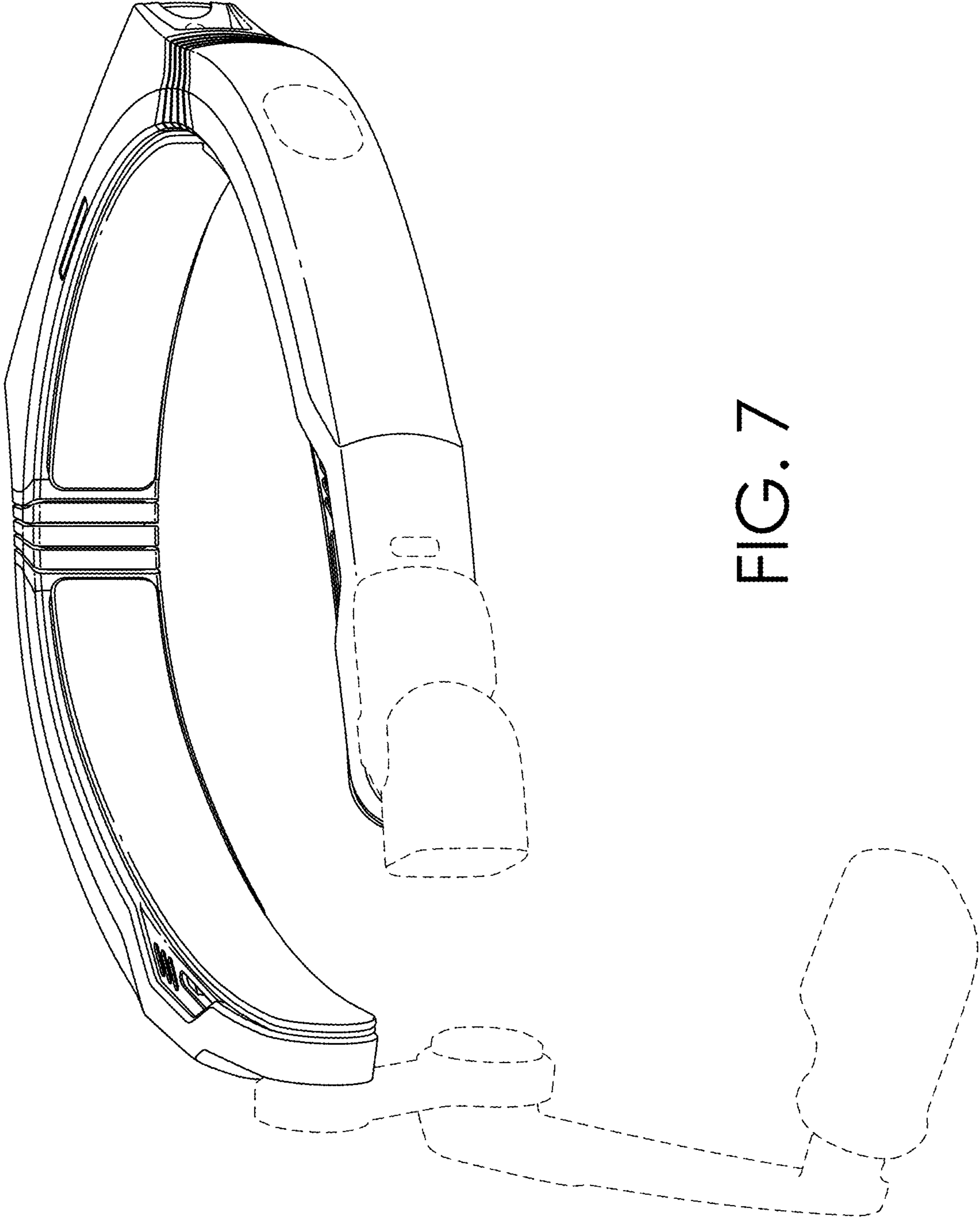

FIG. 7

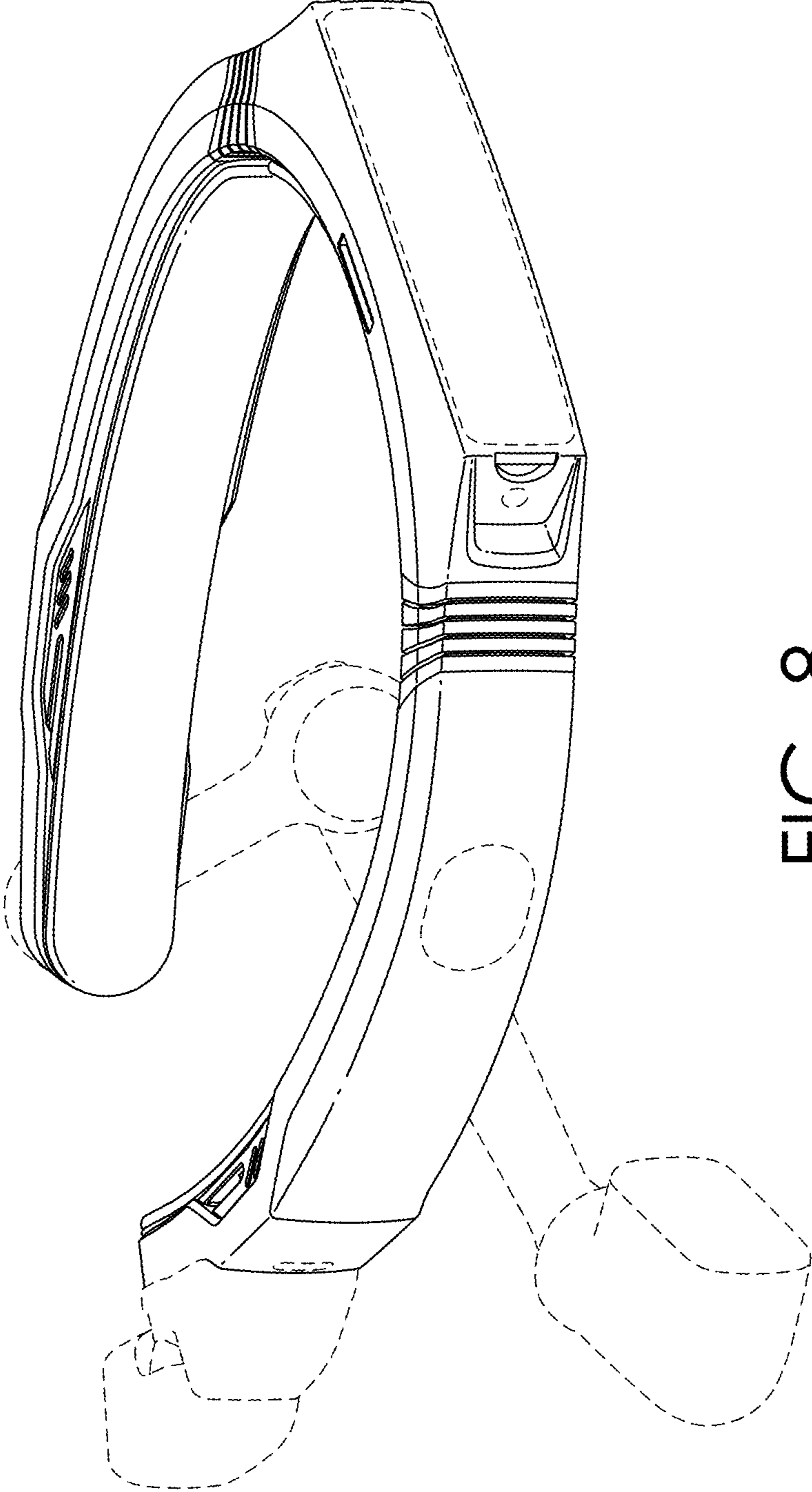

FIG. 8

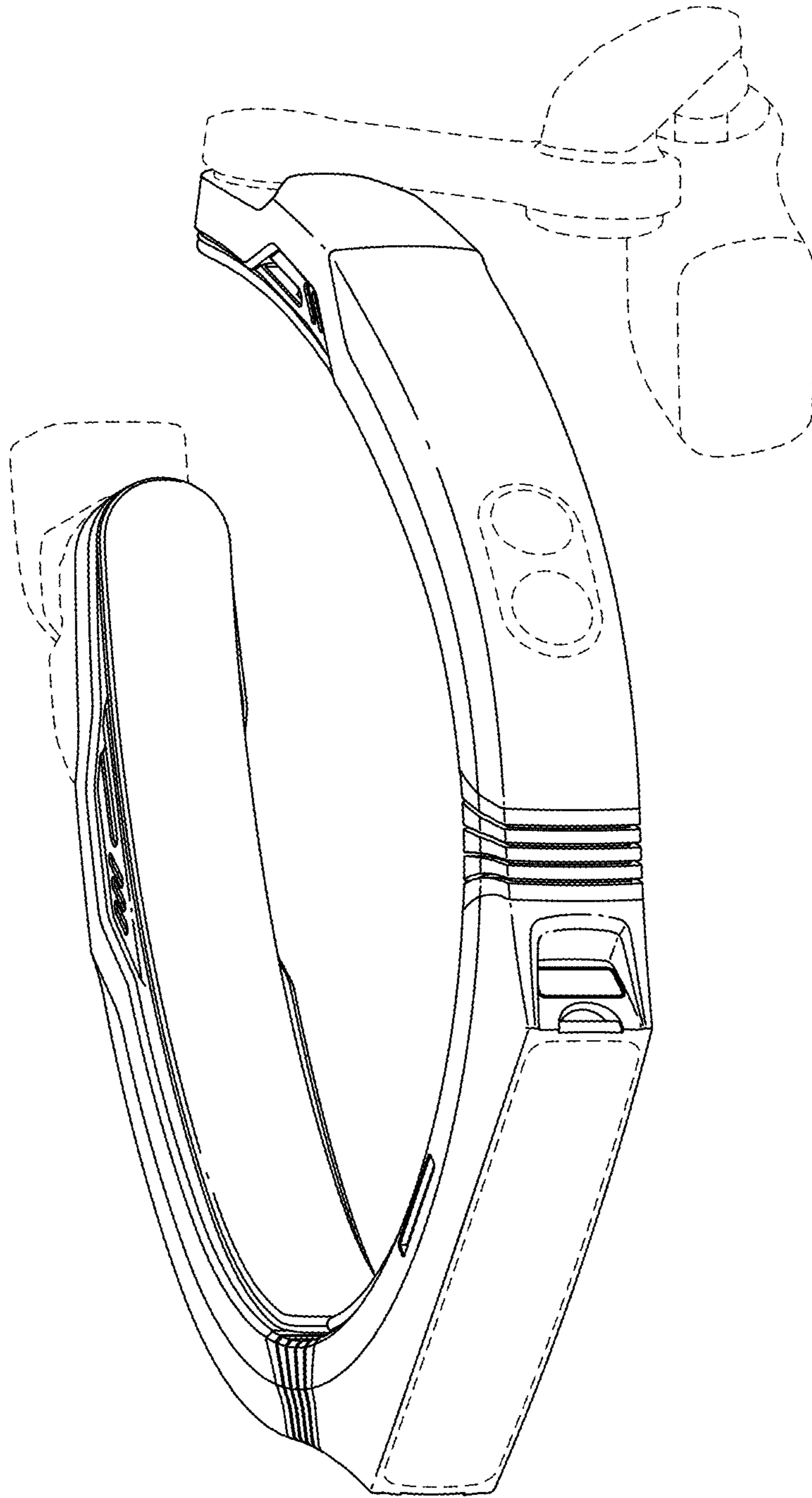

FIG. 9

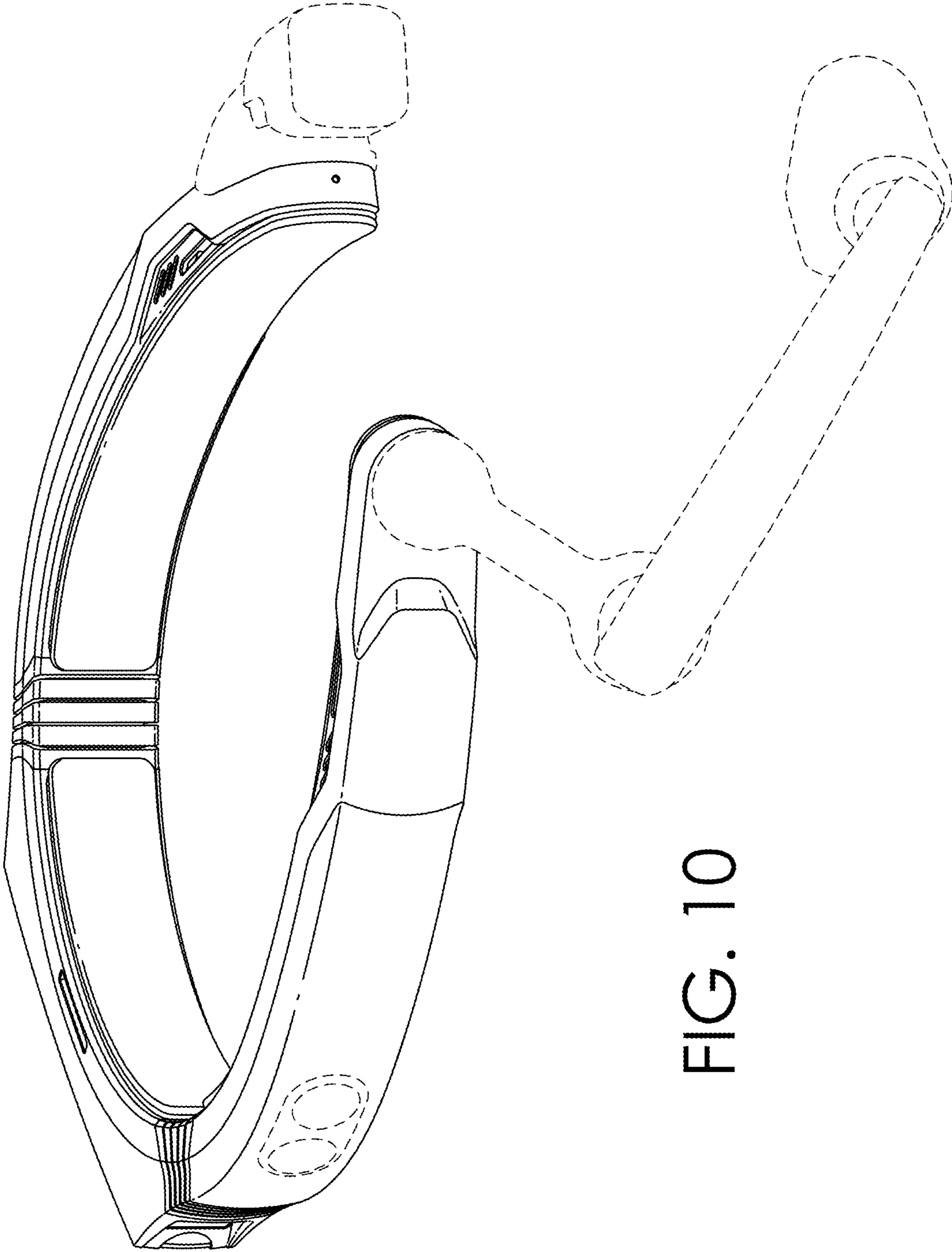

FIG. 10