



US00D930796S

(12) **United States Design Patent** (10) **Patent No.:** **US D930,796 S**
Amano et al. (45) **Date of Patent:** **** *Sep. 14, 2021**

(54) **LIQUID DISCHARGE NOZZLE FOR SEMICONDUCTOR SUBSTRATE PROCESSING APPARATUS**

D637,267 S *	5/2011	Suzuki	D23/213
D823,906 S *	7/2018	Kaminski	D15/135
D824,966 S *	8/2018	Kaminski	D15/135
D903,836 S *	12/2020	Pak	D23/262
D906,485 S *	12/2020	Fowler	D23/259
D907,744 S *	1/2021	Roehl	D23/226

(71) Applicant: **TOKYO ELECTRON LIMITED**,
Tokyo (JP)

(72) Inventors: **Yoshifumi Amano**, Kumamoto (JP);
Kazuhiro Aiura, Kumamoto (JP)

(73) Assignee: **TOKYO ELECTRON LIMITED**,
Tokyo (JP)

(*) Notice: This patent is subject to a terminal disclaimer.

(**) Term: **15 Years**

(21) Appl. No.: **29/744,996**

(22) Filed: **Aug. 3, 2020**

(30) **Foreign Application Priority Data**

Jun. 8, 2020 (JP) 2020-011295

(51) **LOC (13) Cl.** **23-01**

(52) **U.S. Cl.**
USPC **D23/259**

(58) **Field of Classification Search**
USPC D23/213, 214, 215, 223, 224, 226, 229,
D23/230, 249, 259, 262; D15/135
CPC A61H 9/0021; A61H 33/00; B05B 1/00;
B05B 1/14; B05B 1/185; B05B 1/08;
B05B 1/02; B05B 1/26; B05B 12/002;
B05B 1/18; B05B 9/01
See application file for complete search history.

(56) **References Cited**

U.S. PATENT DOCUMENTS

D341,418 S *	11/1993	Akimoto	D23/213
D636,845 S *	4/2011	Suzuki	D23/213

OTHER PUBLICATIONS

Liquid Paste Filling Machine Filling Nozzle Head, Dec. 10, 2020, Amazon.com, May 5, 2021. URL: <https://www.amazon.com/WINUS-Filling-Nozzle-1000ml-Machine/dp/B08G8KPF43> (Year: 2020).*

* cited by examiner

Primary Examiner — Jack Reickel

Assistant Examiner — Keith J Wilson

(74) *Attorney, Agent, or Firm* — Arent Fox LLP; Michael Fainberg

(57) **CLAIM**

The ornamental design for a liquid discharge nozzle for semiconductor substrate processing apparatus, as shown and described.

DESCRIPTION

FIG. 1 is a front, top perspective view of a liquid discharge nozzle for semiconductor substrate processing apparatus showing our new design; FIG. 2 is a front elevational view thereof; FIG. 3 is a rear elevational view thereof; FIG. 4 is a left-side elevational view thereof; FIG. 5 is a right-side elevational view thereof; FIG. 6 is a top plan view thereof; and, FIG. 7 is a bottom plan view thereof.

1 Claim, 5 Drawing Sheets

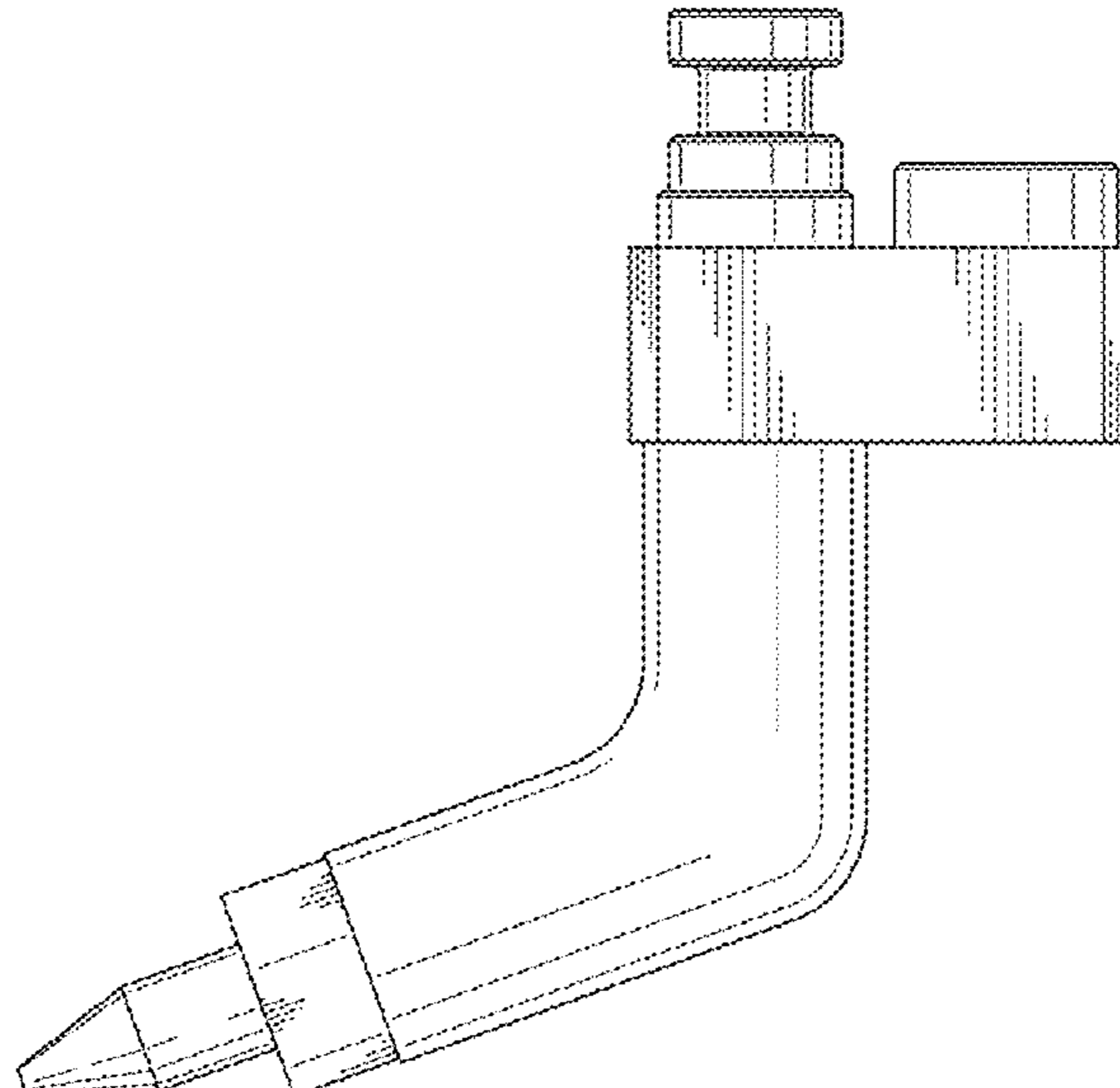
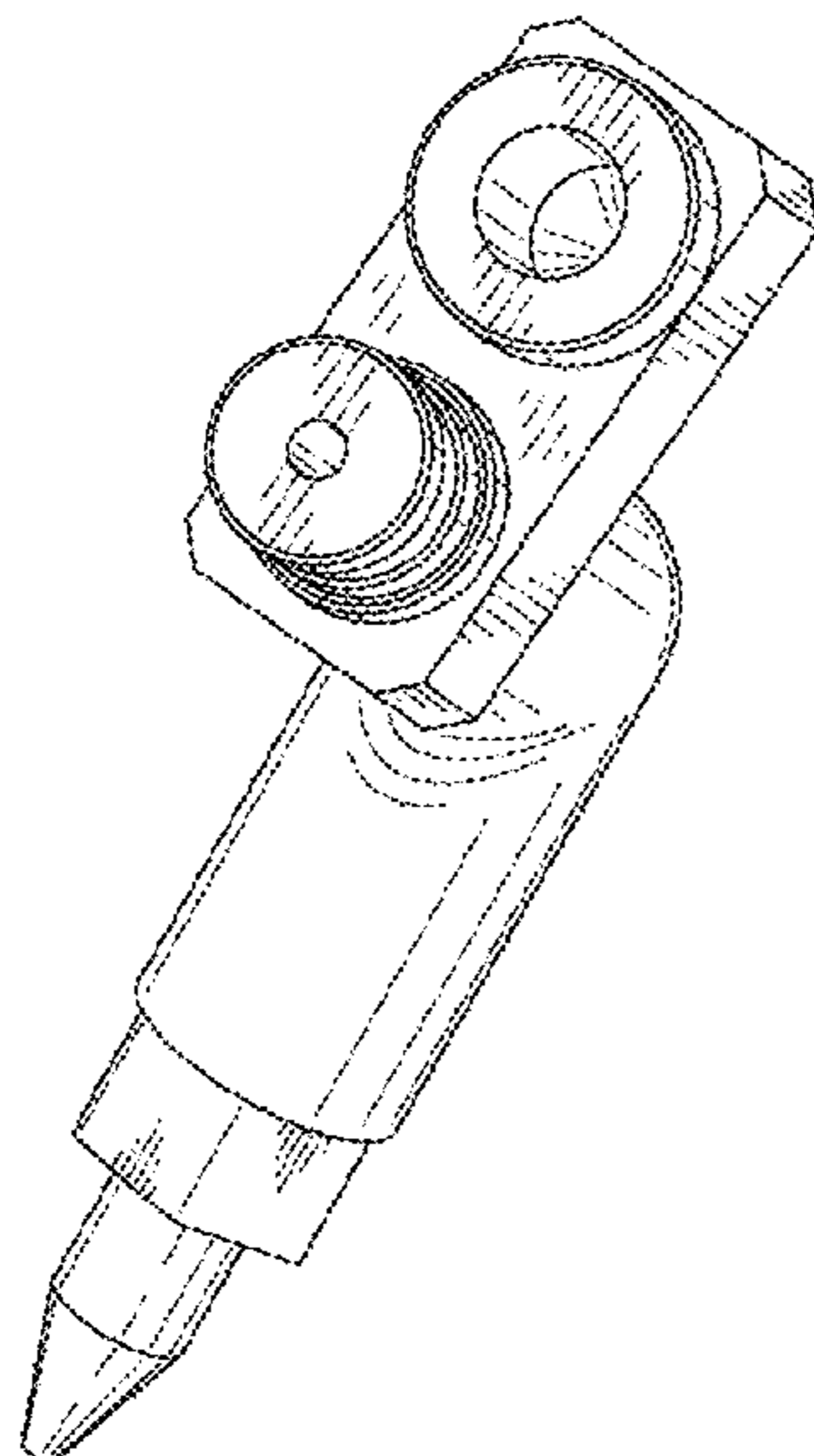

FIG. 1

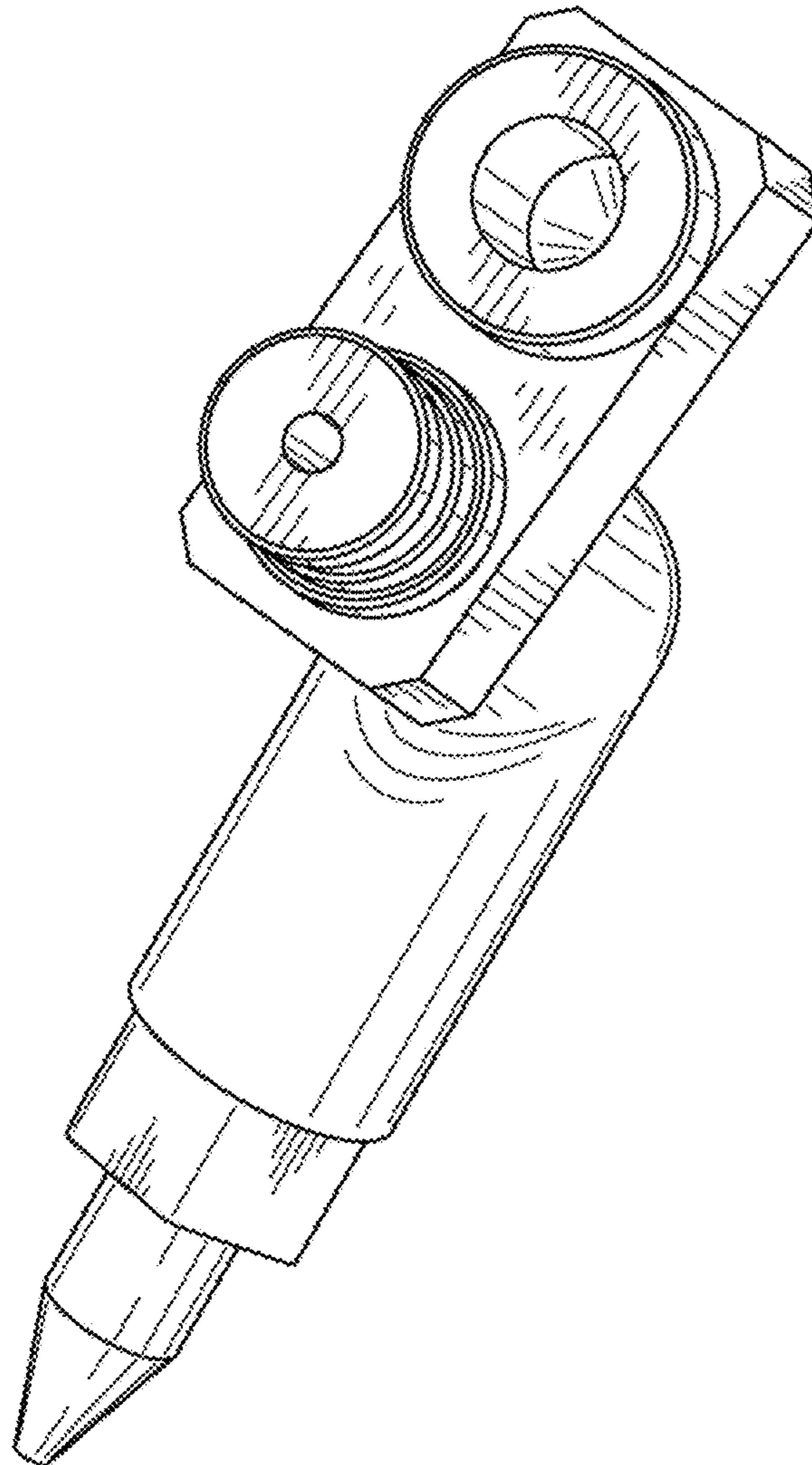

FIG. 2

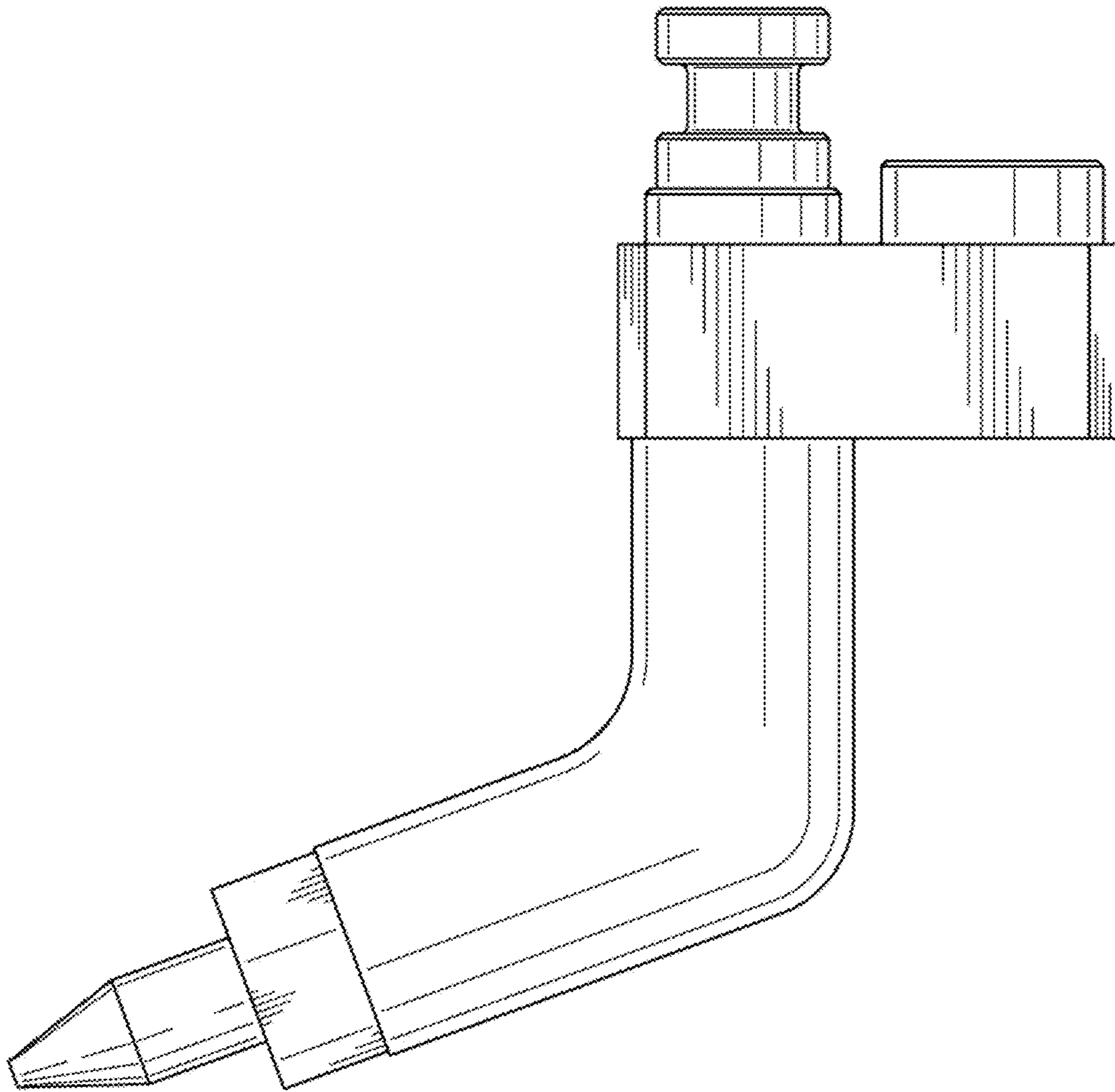

FIG. 3

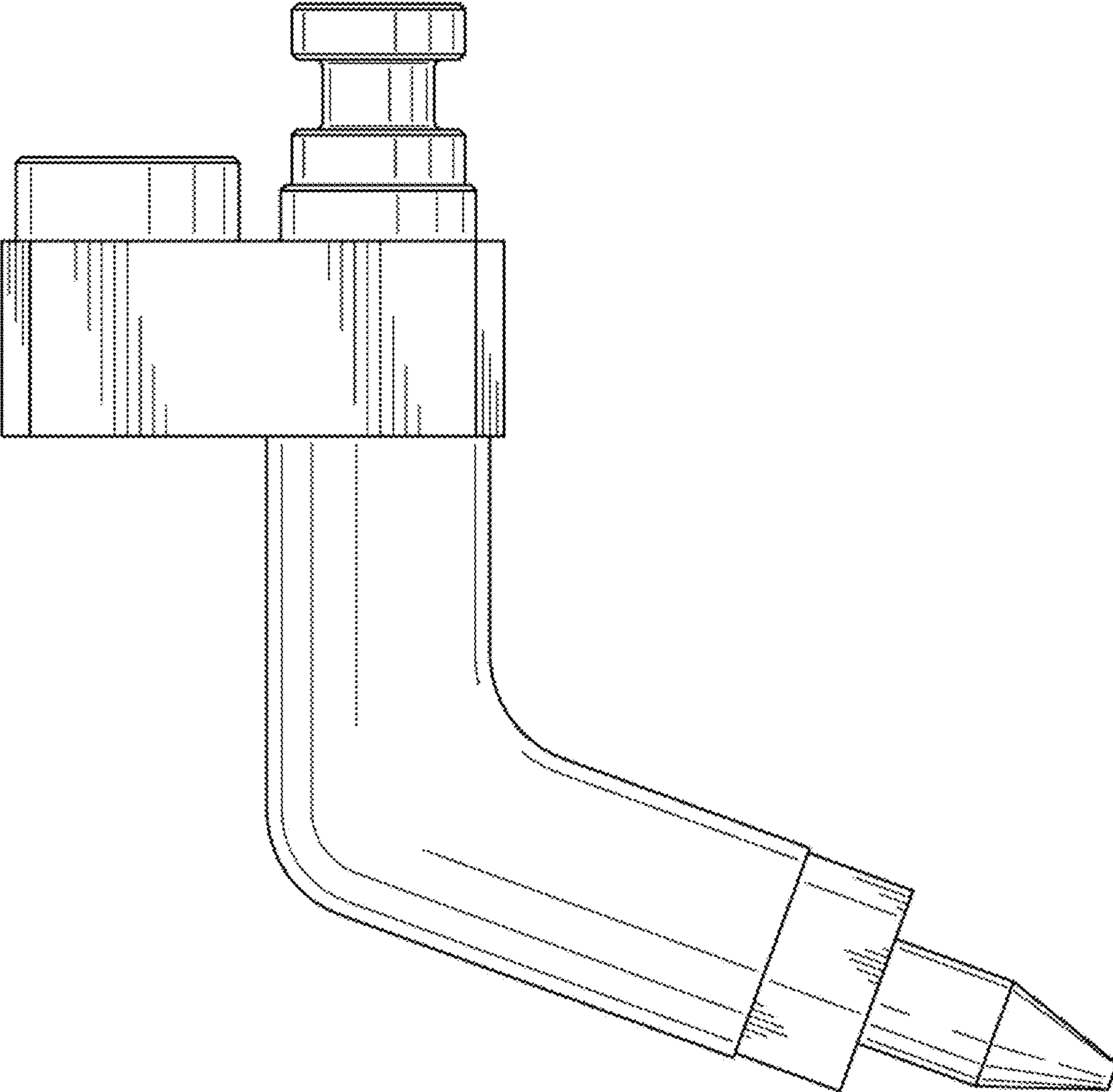

FIG. 4

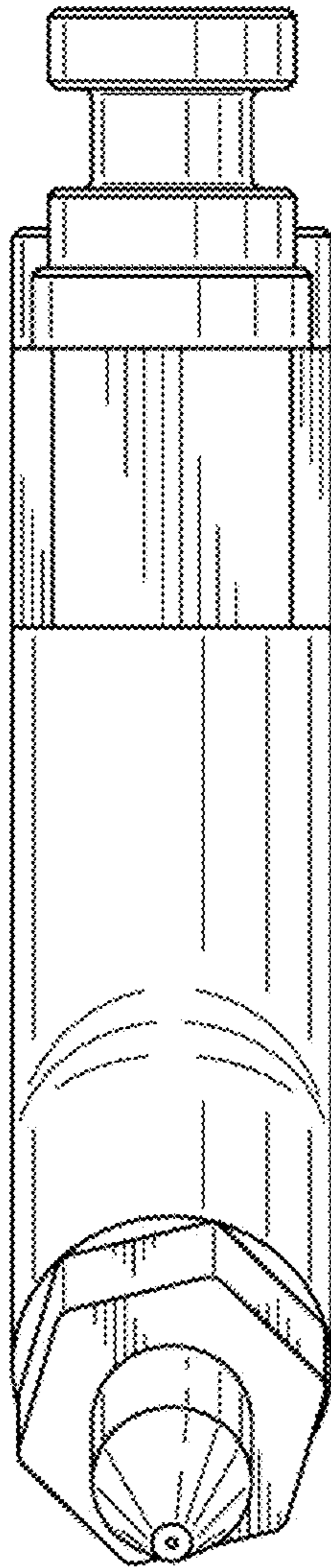

FIG. 5

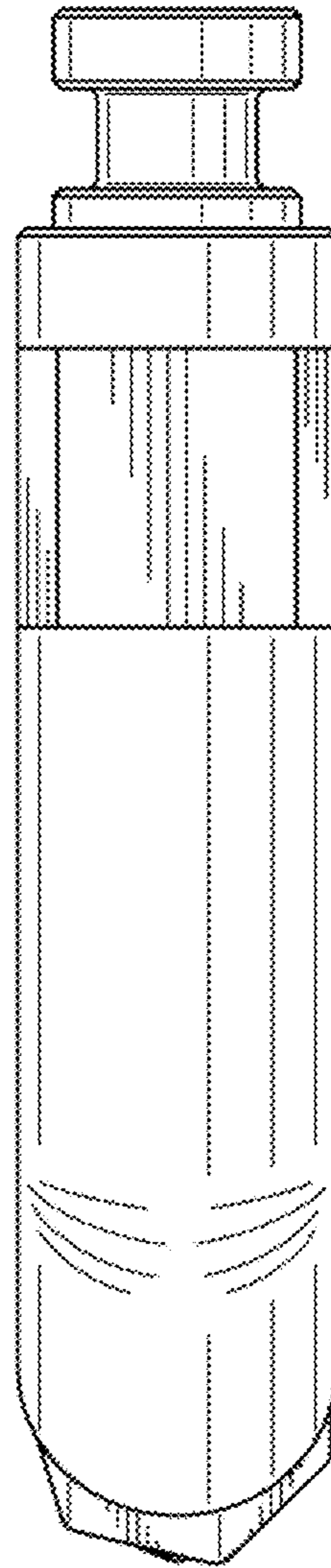

FIG. 6

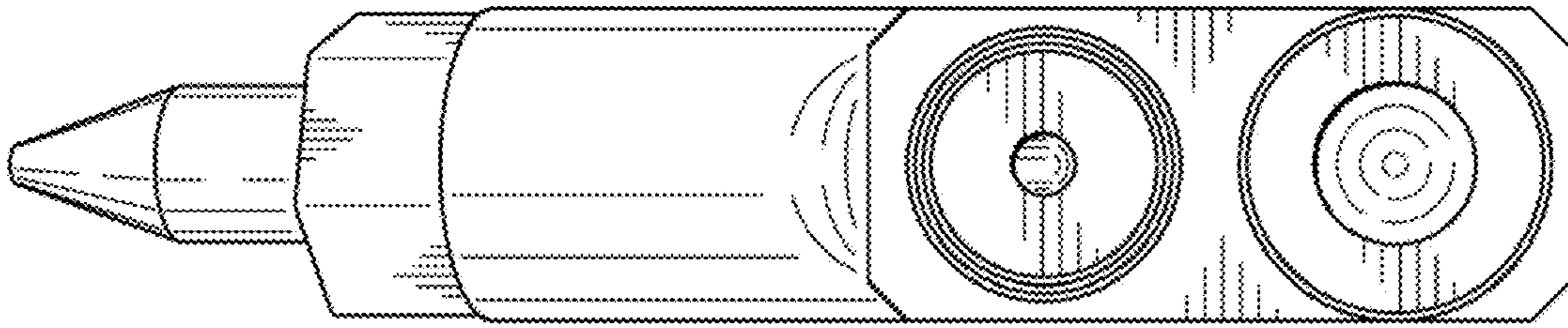

FIG. 7

