



US00D930555S

(12) **United States Design Patent** (10) **Patent No.:** **US D930,555 S**
Choi et al. (45) **Date of Patent:** **** Sep. 14, 2021**

- (54) **CARGO CONTAINER**
- (71) Applicant: **DEKA Products Limited Partnership**,
Manchester, NH (US)
- (72) Inventors: **Sooshin Choi**, Londonderry, NH (US);
Spencer Winfield Trafton, Nashua, NH (US)
- (73) Assignee: **Amoskeag ADV LLC**, Manchester, NH (US)
- (**) Term: **15 Years**
- (21) Appl. No.: **29/725,393**
- (22) Filed: **Feb. 25, 2020**
- (51) **LOC (13) Cl.** **12-16**
- (52) **U.S. Cl.**
USPC **D12/415**
- (58) **Field of Classification Search**
USPC D12/93-96, 98-114, 190, 196, 223,
D12/400-415, 414.1; D3/201, 273, 232,
D3/287, 276, 272, 215, 282, 217, 225,
D3/218, 226, 274; D6/552
CPC B65D 88/14; B65D 88/129; B65D 88/12;
B65D 88/121; B65D 88/00; B65D
88/127; B65D 88/52; B60R 9/00; B60R
9/02; B60R 9/06; B60R 9/08; B60R 9/10;
B60R 9/045; B60R 9/048; B60R 9/055;
B60R 9/058; B62J 7/00; B62J 7/04
See application file for complete search history.

- (56) **References Cited**
U.S. PATENT DOCUMENTS
- | | | | | |
|--------------|---------|---------|-------|---------|
| D260,252 S * | 8/1981 | Groene | | D12/413 |
| D388,027 S | 12/1997 | Polak | | |
| D388,368 S | 12/1997 | Polak | | |
| D408,767 S | 4/1999 | Bar | | |
| D424,483 S | 5/2000 | Tripodi | | |

- | | | | |
|-----------------|---------|-------------------|---------------|
| 6,161,714 A | 12/2000 | Matsuura et al. | |
| D447,460 S * | 9/2001 | Snook | D12/413 |
| D470,084 S | 2/2003 | Schlough | |
| D630,156 S * | 1/2011 | Farber | D12/413 |
| D636,301 S | 4/2011 | Dammacco | |
| D734,029 S | 7/2015 | Lee, II | |
| D740,555 S | 10/2015 | Huber | |
| D740,556 S | 10/2015 | Huber | |
| 9,248,958 B2 | 2/2016 | Pherson | |
| 9,254,857 B2 | 2/2016 | Fiebelkorn | |
| D793,914 S | 8/2017 | Eriksson | |
| D827,939 S | 9/2018 | Jakubowski et al. | |
| D863,203 S * | 10/2019 | Eriksson | D12/413 |
| 10,773,881 B2 | 9/2020 | Pherson et al. | |
| D911,254 S * | 2/2021 | Bourassa | D12/413 |
| 2008/0042379 A1 | 2/2008 | Amran | |
| 2017/0080967 A1 | 3/2017 | Atkins | |
| 2018/0146757 A1 | 5/2018 | Signh Johar | |

* cited by examiner

Primary Examiner — Abraham Bahta
(74) *Attorney, Agent, or Firm* — Toohey Law Group LLC

(57) **CLAIM**

The ornamental design for a cargo container, as shown and described.

DESCRIPTION

FIG. 1 is a front, top, and right side perspective view of the cargo container, showing the new design;
FIG. 2 is a front side elevational view thereof;
FIG. 3 is a rear side elevational view thereof;
FIG. 4 is a left side elevational view thereof;
FIG. 5 is a right side elevational view thereof;
FIG. 6 is a top plan view thereof; and,
FIG. 7 is a bottom plan view thereof.
The ornamental design which is claimed is shown in solid lines in the drawings. Any broken lines in the drawings are for illustrative purposes only and form no part of the claimed design.

1 Claim, 7 Drawing Sheets

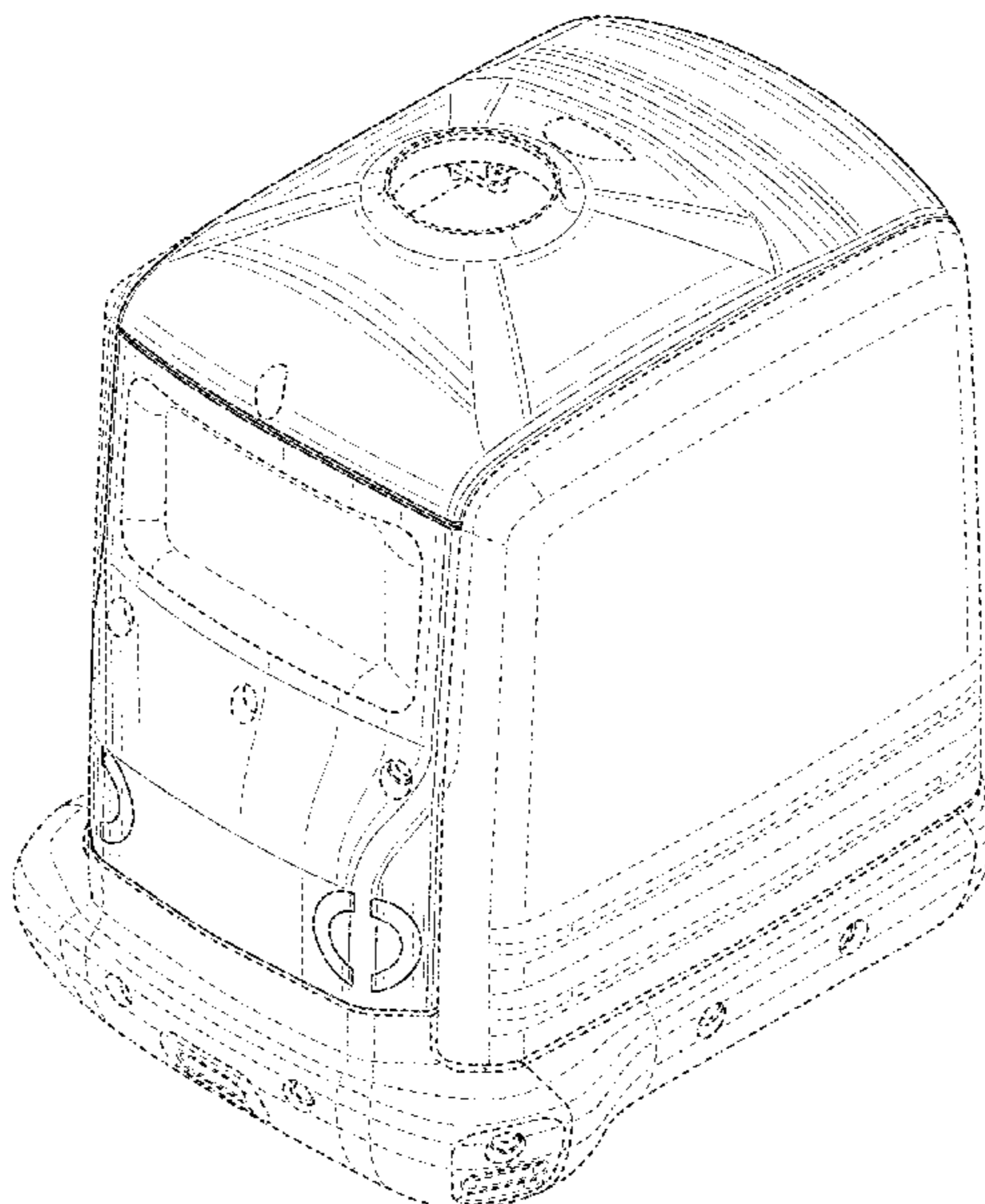

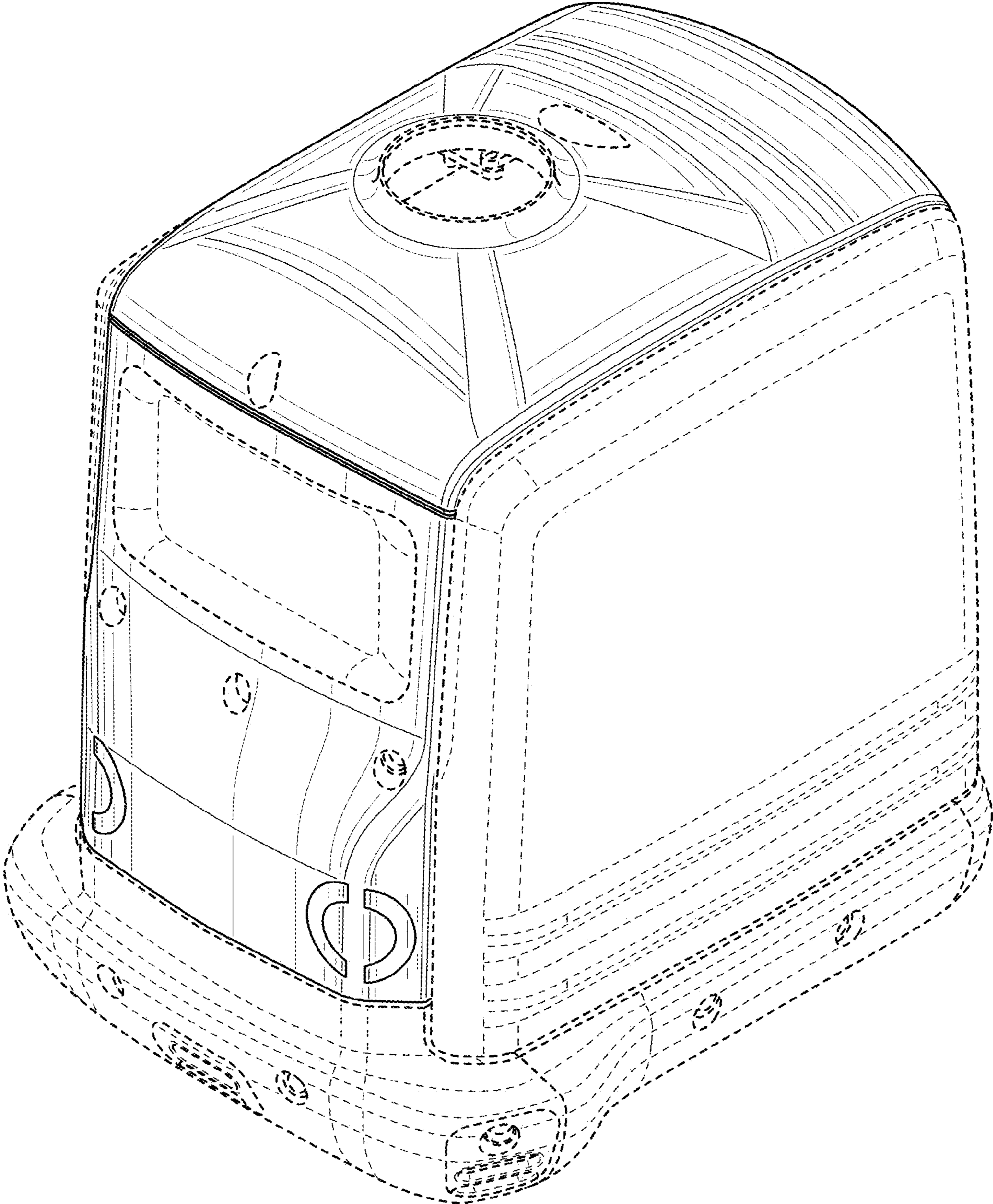

FIG. 1

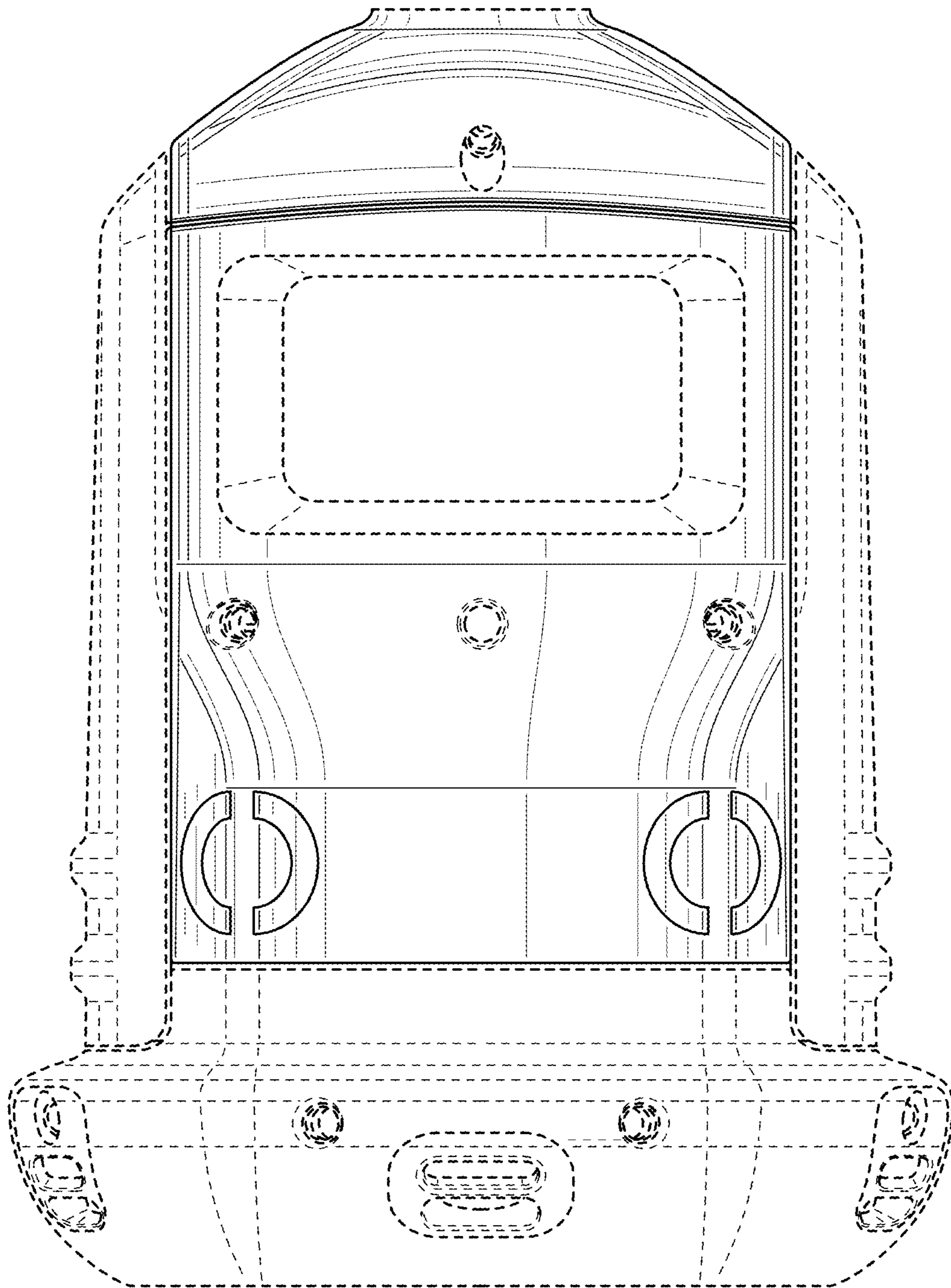

FIG. 2

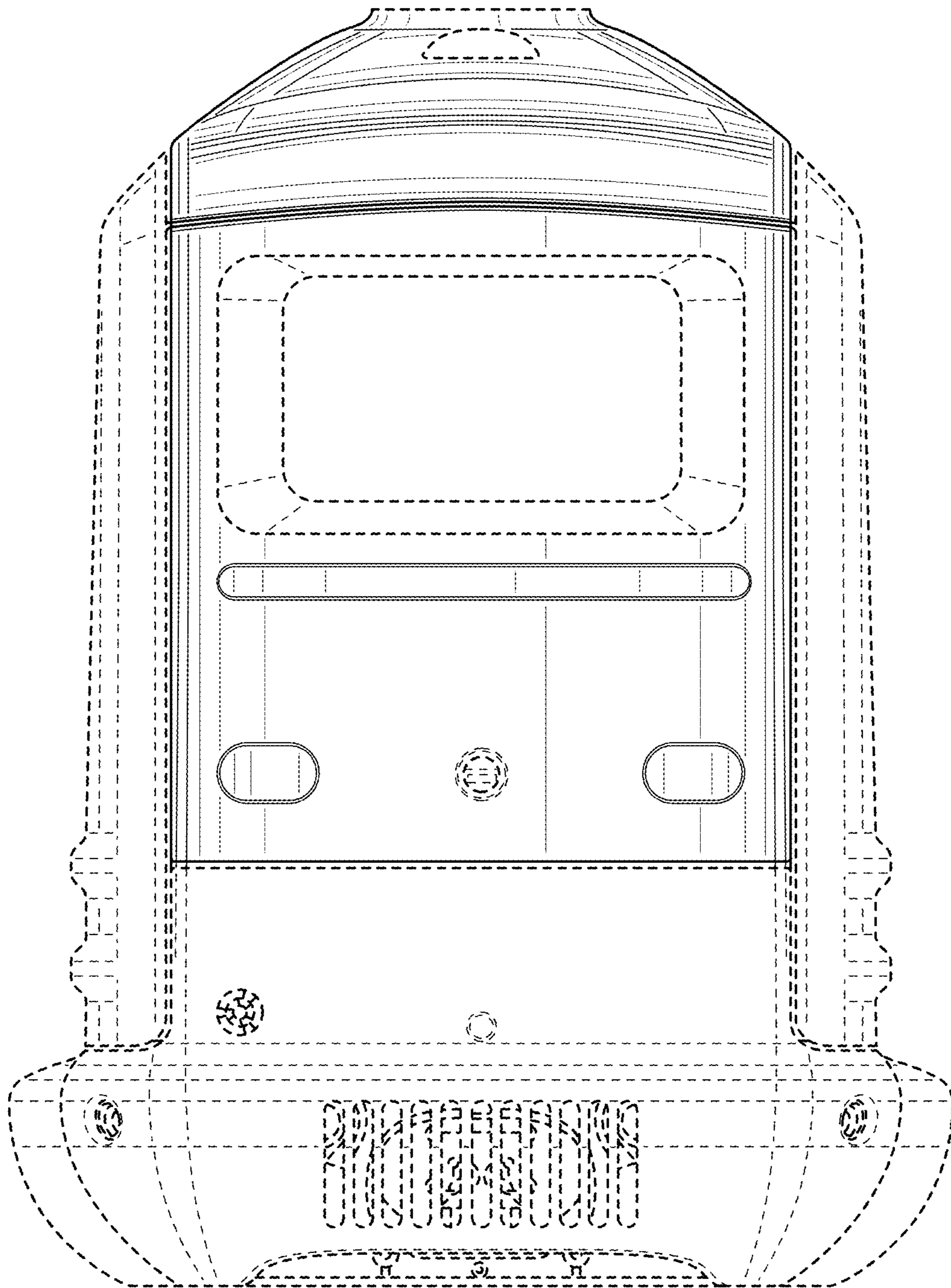

FIG. 3

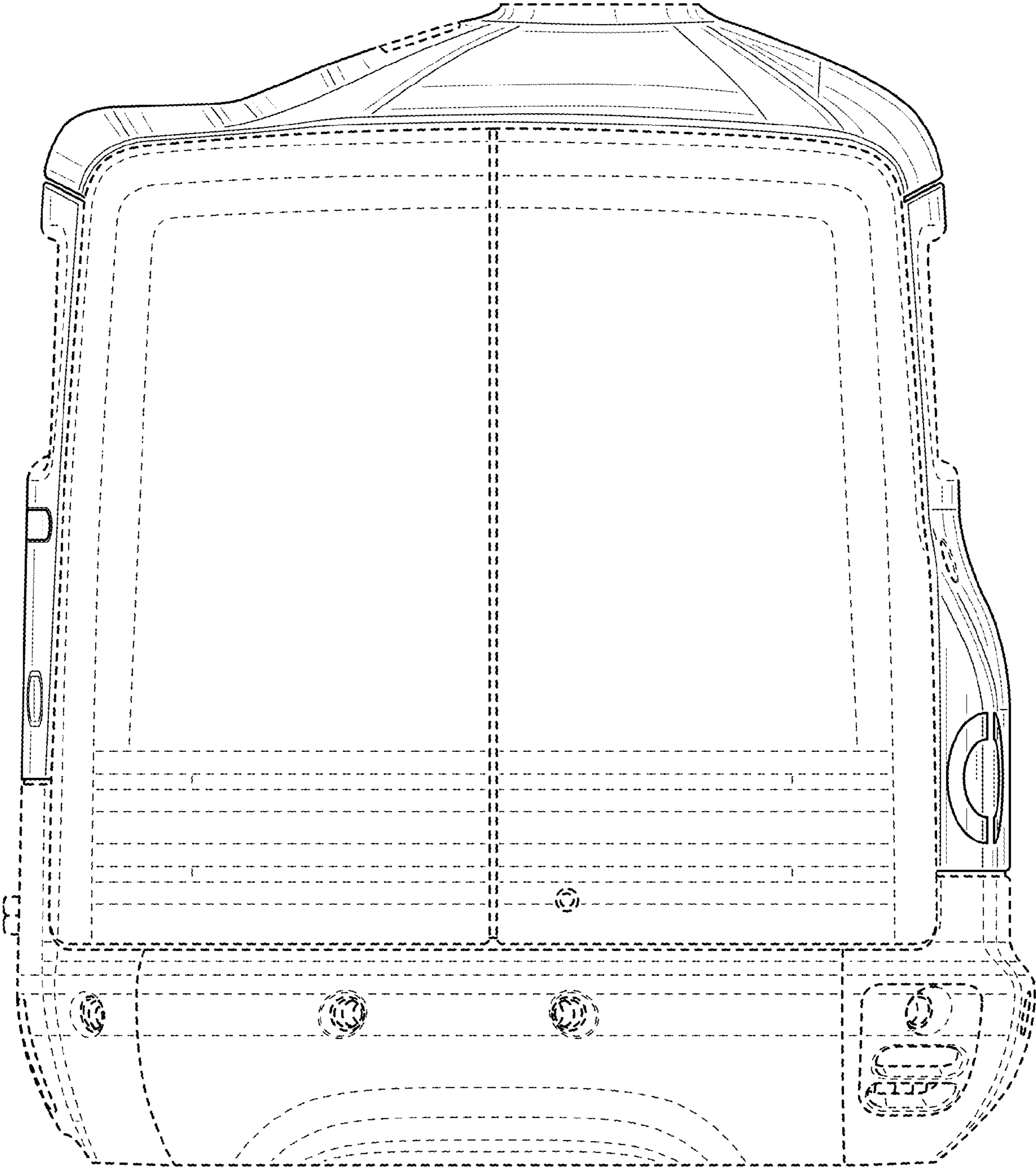

FIG. 4

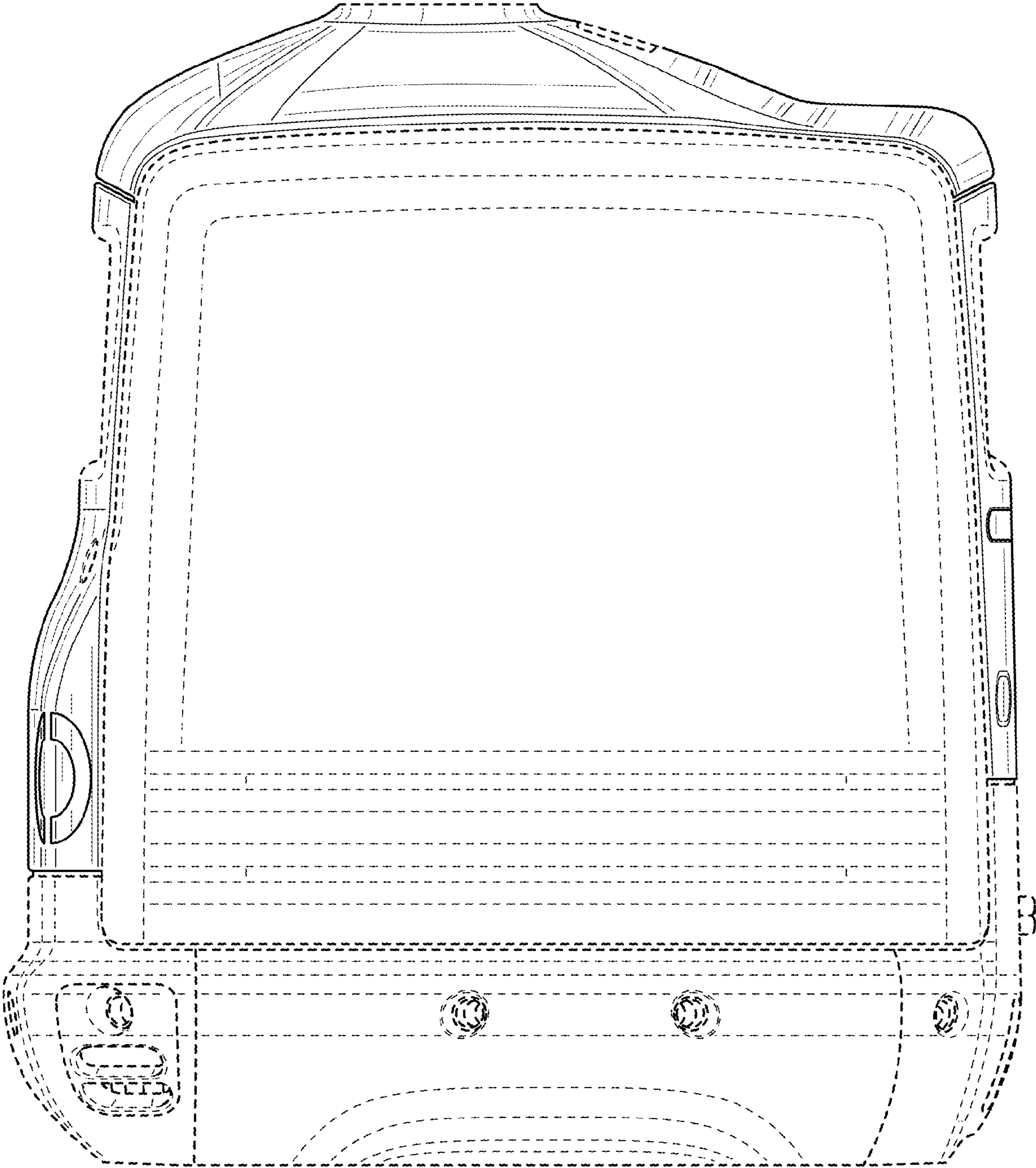

FIG. 5

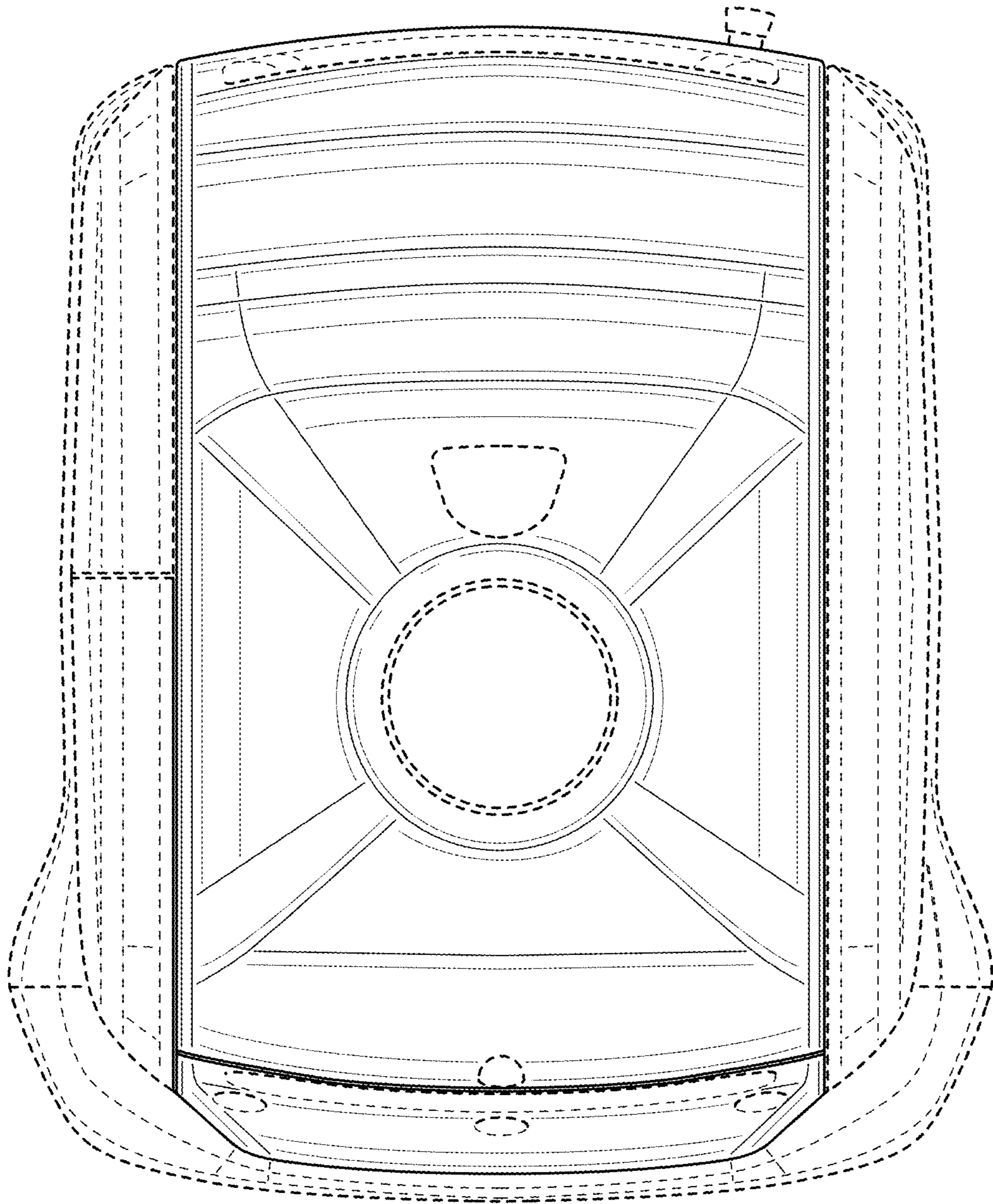

FIG. 6

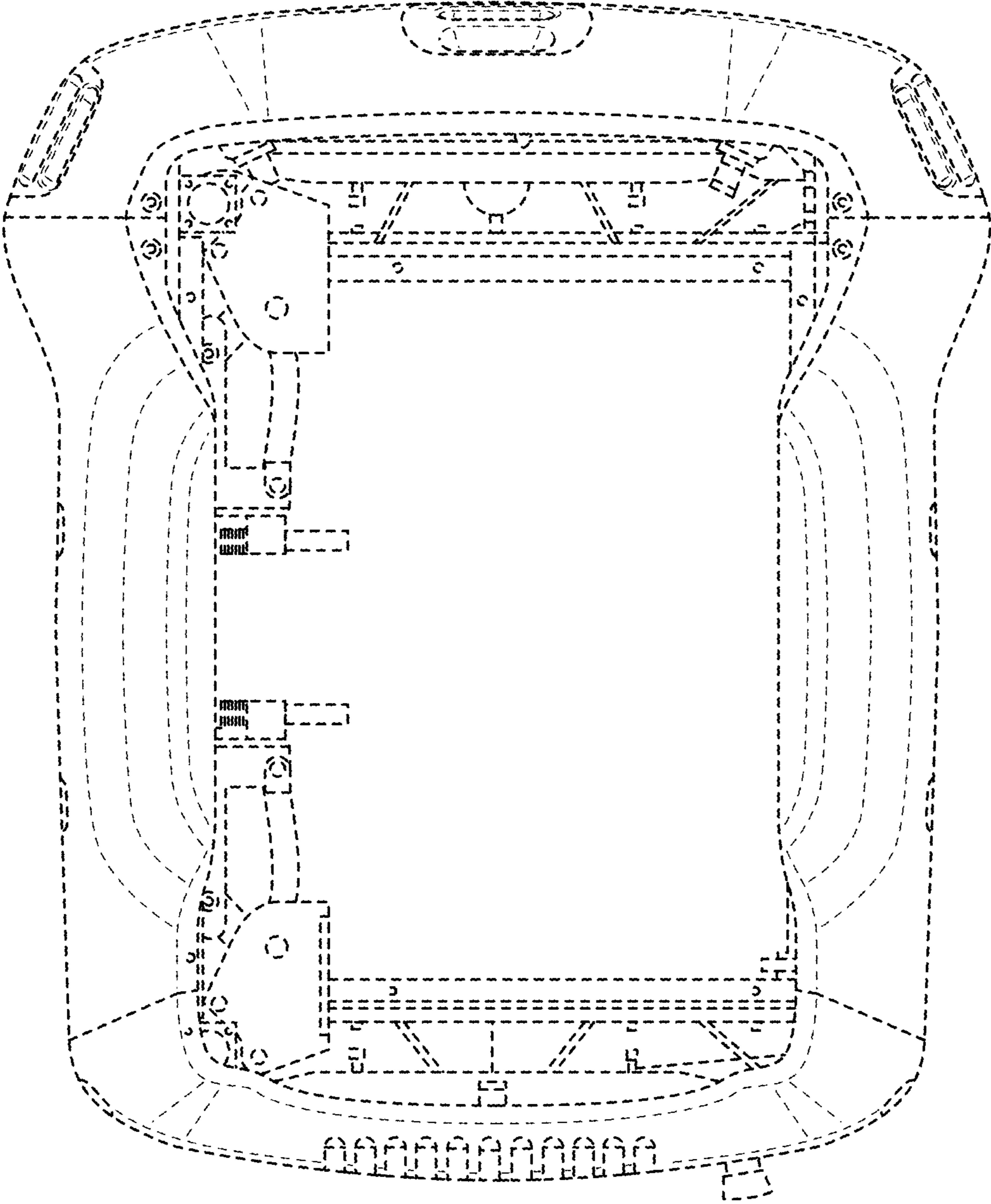

FIG. 7