



US00D930126S

(12) **United States Design Patent** (10) **Patent No.:** **US D930,126 S**
Kumar (45) **Date of Patent:** **** Sep. 7, 2021**

(54) **GASKET**
(71) Applicant: **Transportation IP Holdings, LLC,**
Norwalk, CT (US)
(72) Inventor: **Kotha Ramesh Kumar,** Bangalore (IN)
(73) Assignee: **TRANSPORTATION IP HOLDINGS,**
LLC, Norwalk, CT (US)
(**) Term: **15 Years**

2007/0090608 A1* 4/2007 Ueta F16J 15/0818
277/593
2007/0216109 A1* 9/2007 Friedow F01N 13/1827
277/593
2008/0237998 A1* 10/2008 Chen F16J 15/0818
277/595
2011/0095489 A1* 4/2011 Fatora F16J 15/0825
277/592
2014/0097575 A1* 4/2014 Schumacher F02F 11/002
277/591
2016/0223085 A1* 8/2016 Yamazaki F16J 15/0825
2020/0240520 A1* 7/2020 Aihara F16J 15/122

(21) Appl. No.: **29/713,902**
(22) Filed: **Nov. 19, 2019**
(51) **LOC (13) Cl.** **23-01**
(52) **U.S. Cl.**
USPC **D23/269**
(58) **Field of Classification Search**
USPC D23/259–263, 265, 233, 269;
D8/349–350, 352, 354, 382; D15/5, 28;
D12/194, 213
CPC F02F 11/00
See application file for complete search history.

OTHER PUBLICATIONS

Kumar, K., "Sealing Apparatus With Retention Ribs," U.S. Appl. No. 29/713,904, filed Nov. 19, 2019, 10 pages.
Kumar, K. et al., "Engine Coolant System and Method," U.S. Appl. No. 16/688,939, filed Nov. 19, 2019, 46 pages.
Kumar, K., "Engine Cylinder Liner With Linear Catcher," U.S. Appl. No. 16/688,863, filed Nov. 19, 2019, 22 pages.

* cited by examiner

Primary Examiner — Amy C Wierenga
(74) *Attorney, Agent, or Firm* — McCoy Russell LLP

(56) **References Cited**

U.S. PATENT DOCUMENTS

4,620,710 A * 11/1986 Lambert F16J 15/123
277/596
5,074,578 A * 12/1991 Grove B62D 17/00
280/86.753
5,105,777 A * 4/1992 Kronich F02F 11/002
123/193.3
6,019,376 A * 2/2000 Miyaoh F16J 15/0825
277/593
7,347,176 B1* 3/2008 Estacio F02F 11/00
123/195 R
D611,577 S * 3/2010 Waymire D23/266
D644,721 S * 9/2011 Bond D23/269
D644,722 S * 9/2011 Bond D23/269
D647,181 S * 10/2011 Kovach D23/259
D747,445 S * 1/2016 Salvo D23/269

(57) **CLAIM**

The ornamental design for a gasket, as shown and described.

DESCRIPTION

FIG. 1 is a front perspective view of a gasket according to the present invention.
FIG. 2 is a front view of the gasket.
FIG. 3 is a rear view of the gasket.
FIG. 4 is a left side view of the gasket.
FIG. 5 is a right side view of the gasket.
FIG. 6 is a bottom view of the gasket; and,
FIG. 7 is a top view of the gasket.
The dashed broken lines depict portions of the gasket that form no part of the claim.

1 Claim, 5 Drawing Sheets

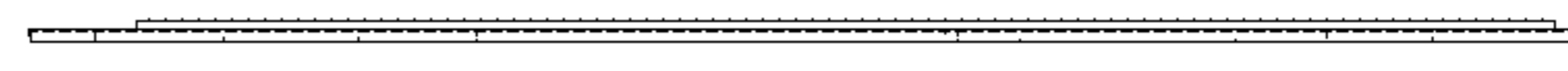
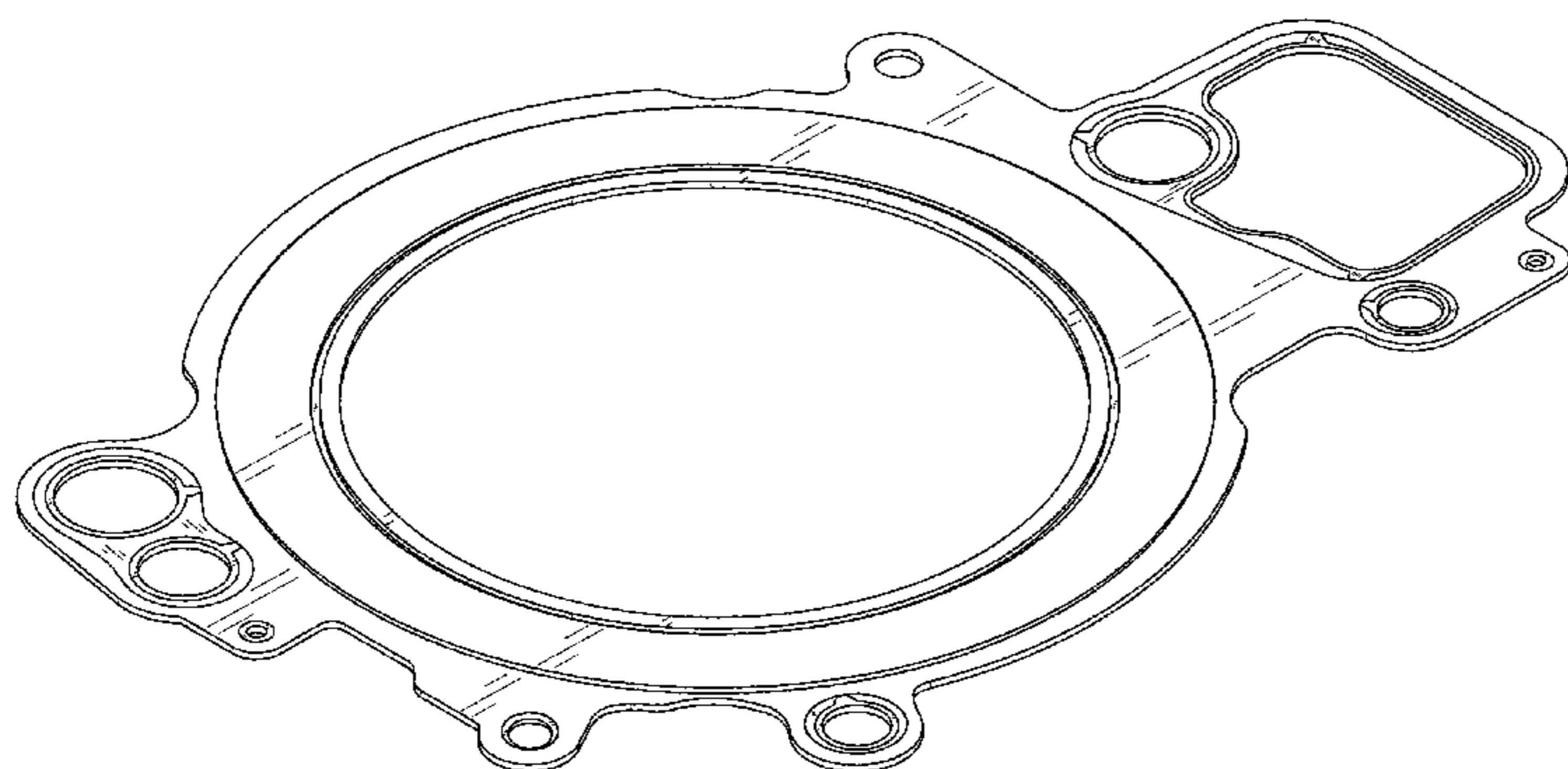

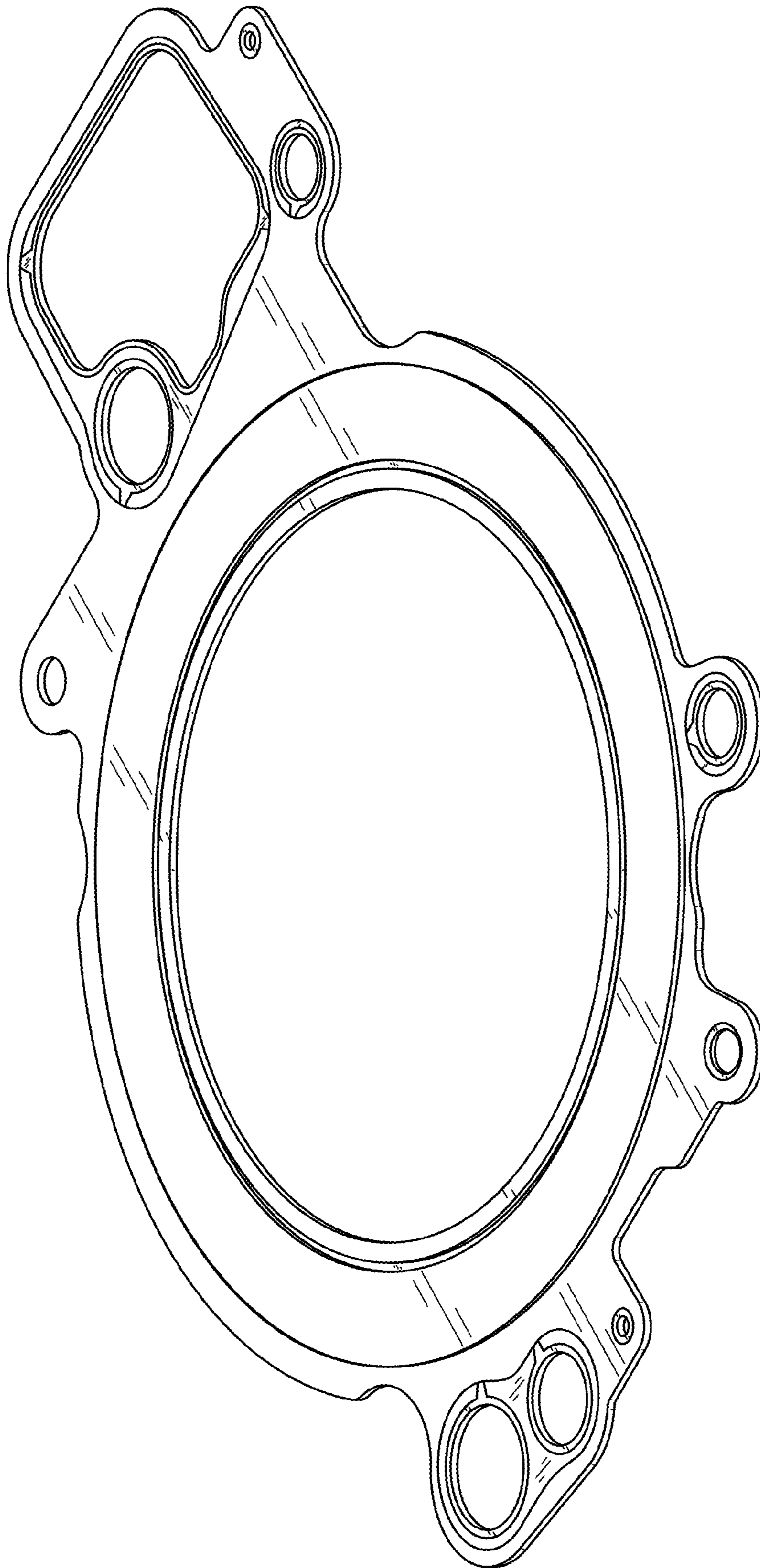

FIG. 1

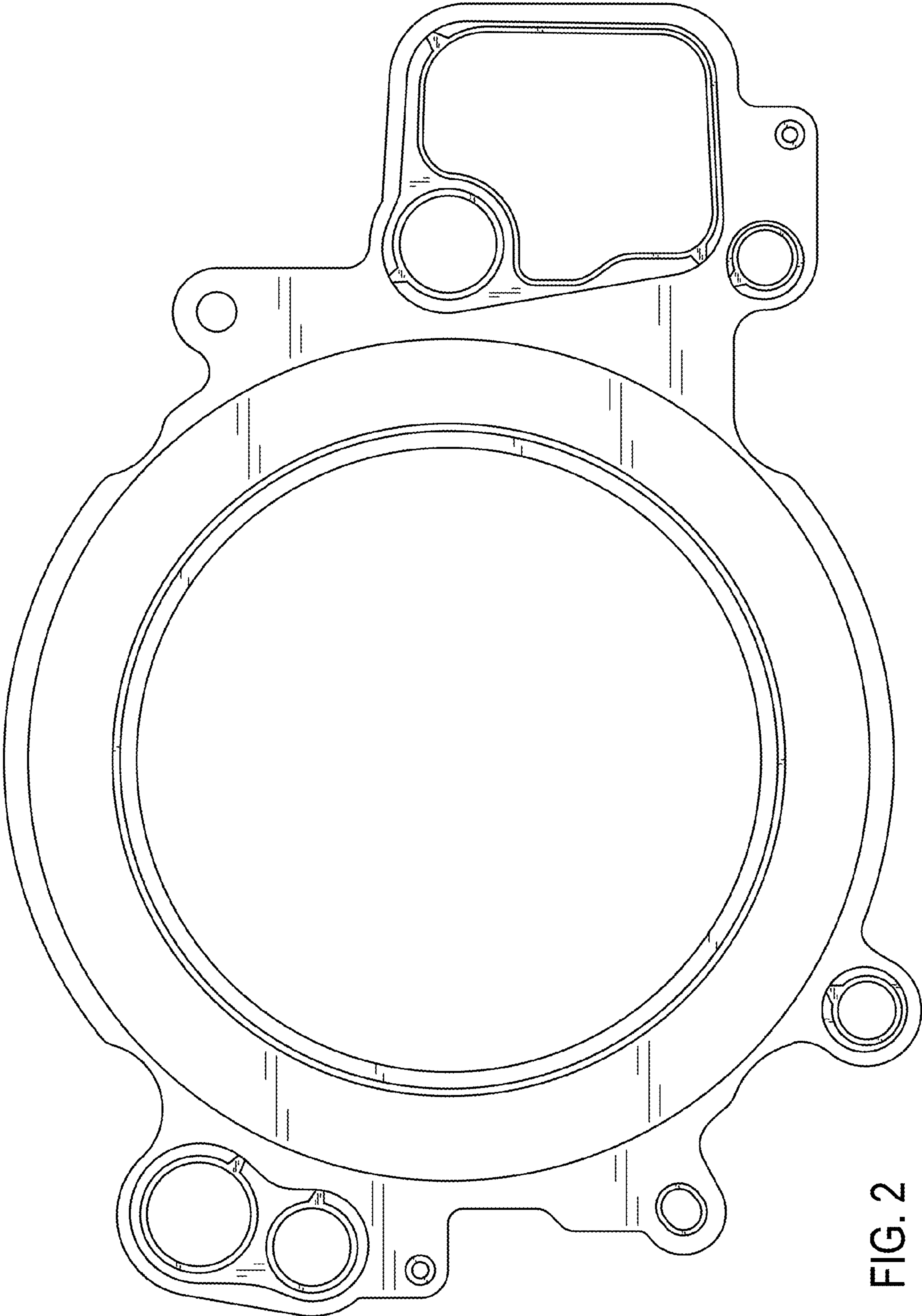

FIG. 2

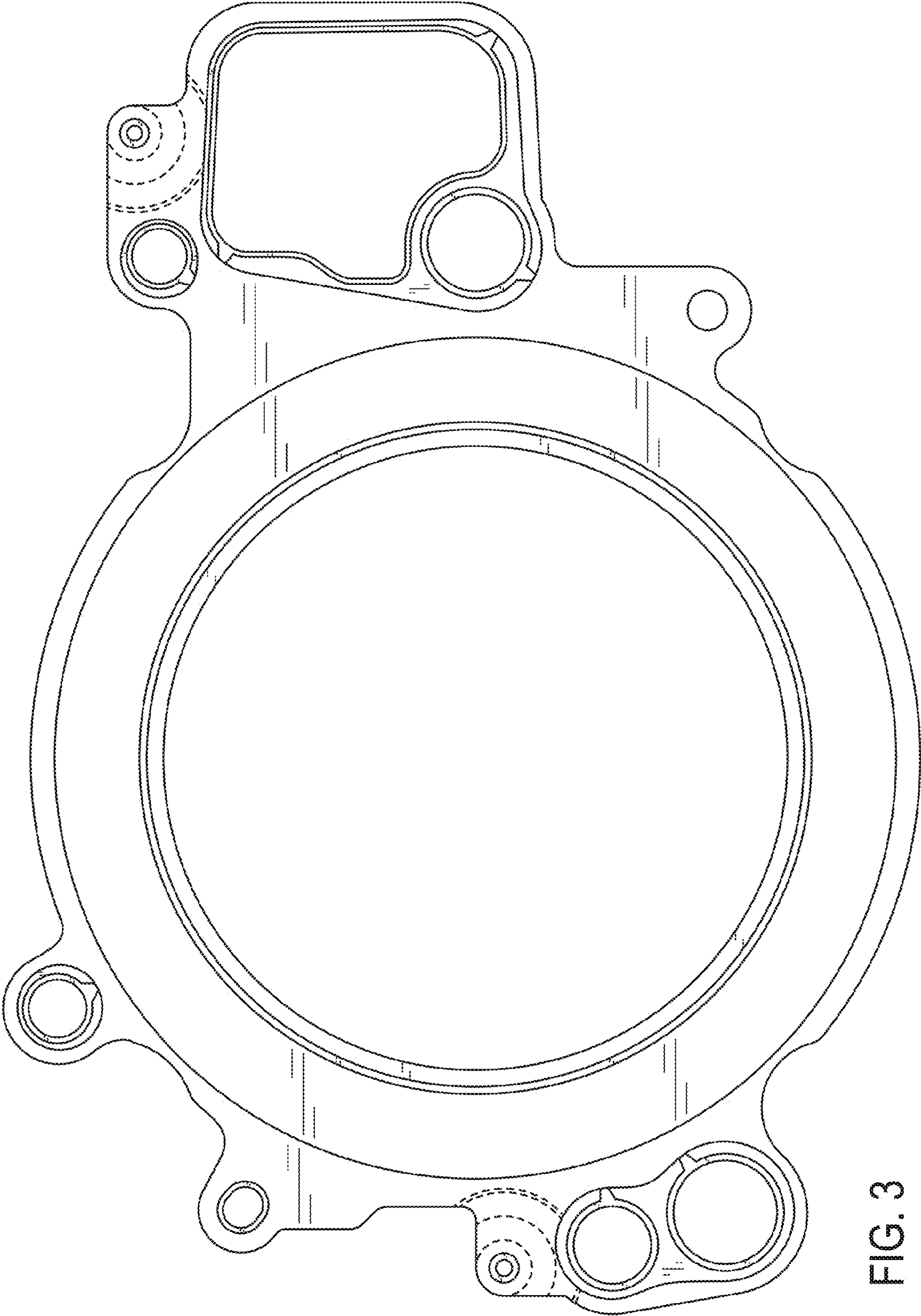

FIG. 3



FIG. 4



FIG. 5



FIG. 6



FIG. 7