



US00D930069S

(12) **United States Design Patent** (10) **Patent No.:** **US D930,069 S**
Stanley et al. (45) **Date of Patent:** **** Sep. 7, 2021**

(54) **PLATFORM**

(71) Applicants: **Alicia Harvey Stanley**, Gaithersburg, MD (US); **Briar D. Robinson**, Gaithersburg, MD (US); **Robert Walter Kenny, Jr.**, Mount Airy, MD (US); **Exus D. Altimus**, Manassas, VA (US); **William B. Harvey**, Laytonsville, MD (US)

6,538,185 B1 3/2003 Stratton
7,485,792 B2 2/2009 Collins, Sr.
8,614,385 B2 12/2013 McKinney et al.
9,401,133 B2 7/2016 McGinly
D769,364 S 10/2016 Trifilio
D781,954 S 3/2017 Wilfer
9,620,094 B2 4/2017 Abbate
9,691,369 B2 6/2017 Trifilio
D792,503 S 7/2017 Helweg
D795,334 S 8/2017 Kreifeldt et al.
D815,682 S 4/2018 Trifilio et al.

(Continued)

(72) Inventors: **Alicia Harvey Stanley**, Gaithersburg, MD (US); **Briar D. Robinson**, Gaithersburg, MD (US); **Robert Walter Kenny, Jr.**, Mount Airy, MD (US); **Exus D. Altimus**, Manassas, VA (US); **William B. Harvey**, Laytonsville, MD (US)

FOREIGN PATENT DOCUMENTS

GB 2544517 5/2017
KR 101917599 11/2018

OTHER PUBLICATIONS

Accel Audio Pedalboards, <https://www.accelaudio.com/pedalboards> (Last updated Mar. 20, 2019).

(Continued)

(73) Assignee: **Alicia Harvey Stanley**, Gaithersburg, MD (US)

(**) Term: **15 Years**

Primary Examiner — Gino Colan

(21) Appl. No.: **29/692,479**

(57) **CLAIM**

(22) Filed: **May 24, 2019**

The ornamental design for a platform, as shown and described.

(51) **LOC (13) Cl.** **17-99**

(52) **U.S. Cl.**
USPC **D17/99**

DESCRIPTION

(58) **Field of Classification Search**
USPC D17/20, 99, 9, 22, 21, 24; 84/426, 366, 84/721, 225, 421, 424, 444, 453; D6/329, 641, 650, 707, 512, 513, 514; D14/217, 219, 229, 432, 299
CPC G10B 3/14; G10D 13/11
See application file for complete search history.

FIG. 1 is a front isometric view of our new design for a platform showing our new design; FIG. 2 is a front elevational view of FIG. 1; FIG. 3 is a back elevational view of FIG. 1; FIG. 4 is a right side elevational view of FIG. 1; FIG. 5 is a left side elevational of FIG. 1; FIG. 6 is a top plan view of FIG. 1; and, FIG. 7 is a bottom plan view of FIG. 1.

The features shown in broken lines in the drawings depict environmental subject matter only and form no part of the claimed design.

(56) **References Cited**

U.S. PATENT DOCUMENTS

4,151,774 A 5/1979 Klann
6,459,023 B1 10/2002 Chandler

1 Claim, 5 Drawing Sheets

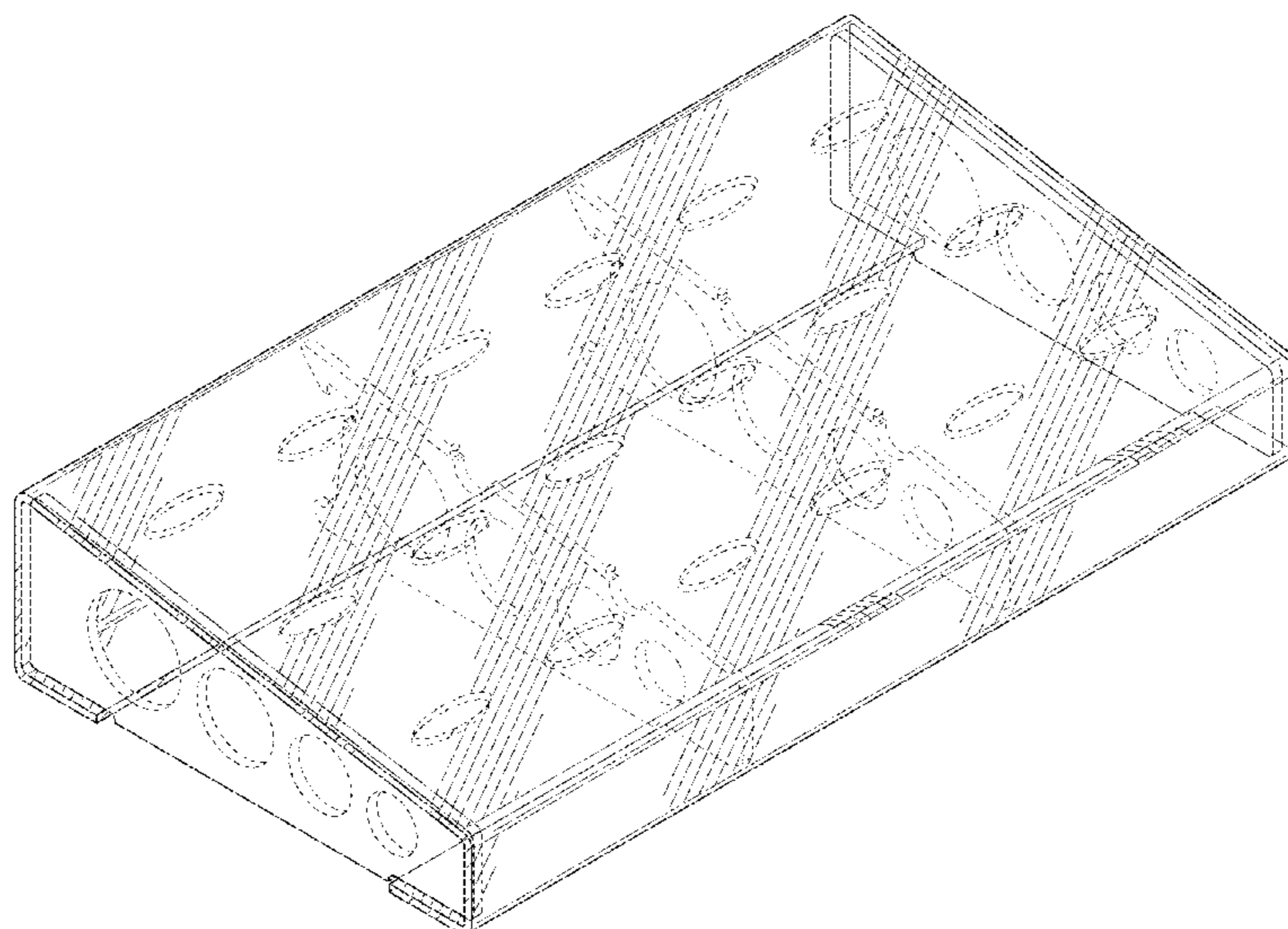

(56)

References Cited

U.S. PATENT DOCUMENTS

D820,904	S *	6/2018	Fiden	D17/99
9,997,149	B2	6/2018	Trifilio	
10,008,192	B2	6/2018	Kreifeldt et al.	
D838,575	S	1/2019	Helweg	
10,204,609	B2	2/2019	Grifols	
D862,578	S *	10/2019	Lackner	D17/20
D862,579	S *	10/2019	Lackner	D17/20
D862,582	S *	10/2019	Lackner	D17/20
D862,583	S *	10/2019	Lackner	D17/20
D907,692	S *	1/2021	Wilfer	D17/99
2004/0250673	A1	12/2004	Salerno	

OTHER PUBLICATIONS

Blackbird Pedalboards, 1224 Tolex Series with ATA Case, <https://blackbirdpedalboards.com/product/1224-tolex-series-with-ata-case/> (YouTube video dated Oct. 3, 2017).

Boss BCB-60 Pedalboard, <https://www.boss.info/us/products/bcb-60/> (Last updated Jan. 2019).
 Creation Music Company Pedalboards, <https://creationmusiccompany.com/> (Last updated Jan. 2019).
 HoleyBoard Pedalboard, <https://holeyboardpedalboards.com/> (YouTube video dated Apr. 24, 2020).
 Pedaltrain Classic 2 with Tour Case, <https://pedaltrain.com/products/pt-cl2-tc> (Viewed on Feb. 22, 2019).
 Salvage Custom Pedalboard, <https://reverb.com/item/5640617-salvage-custom-pedalboard> (Listed for Sale 2017).
 Schmidt Array Taurus Pedalboards, <https://www.schmidtarray.com/shop-6> (Last updated Dec. 2017).
 Trailer Trash Pedalboards, <http://trailertrashpedalboards.com/the-boards> (Last updated Dec. 2019).
 Voodoo Lab Dingbat Pedalboards, http://www.voodoolab.com/dingbat_landing.html (Last Updated Nov. 2019).
 List of Patents or Applications Treated as Related, Jul. 2020.

* cited by examiner

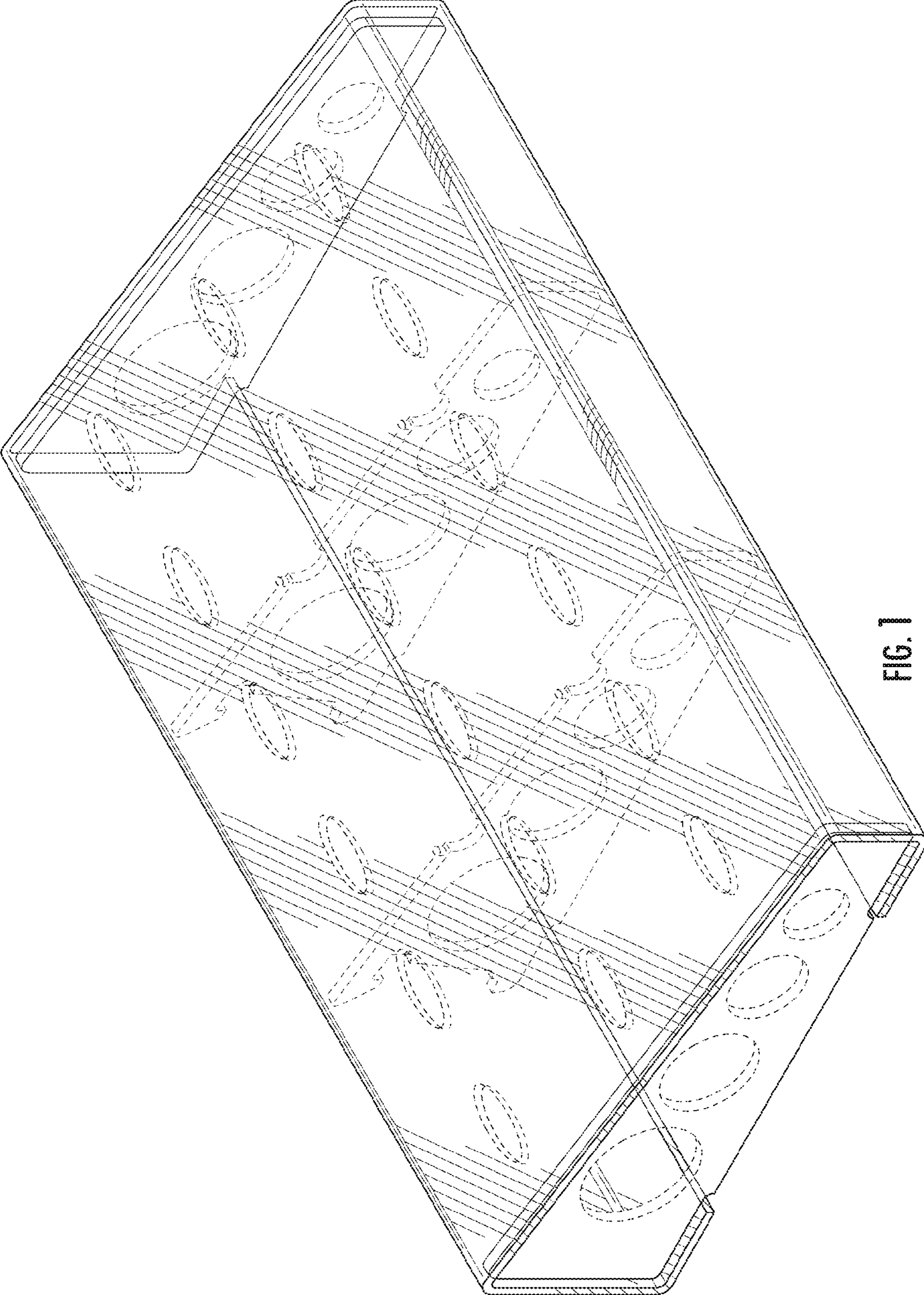

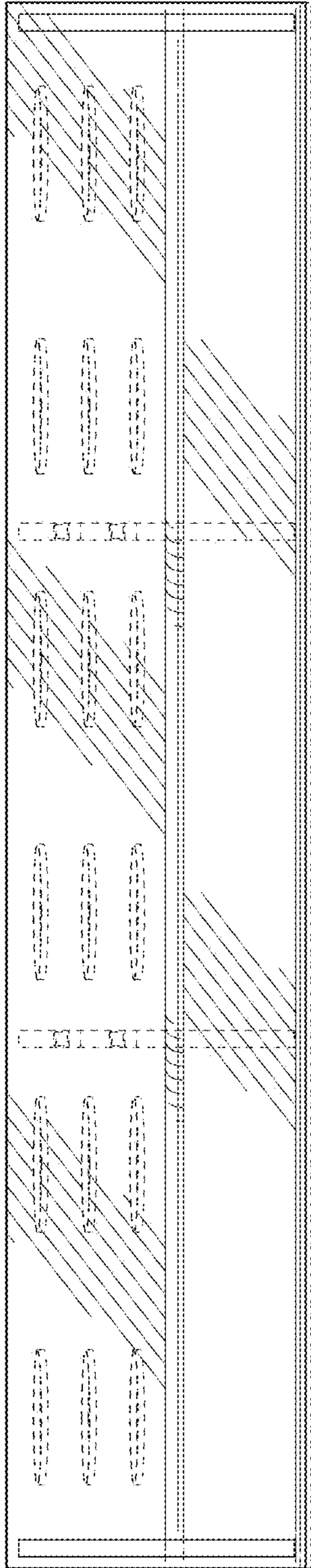

FIG. 2

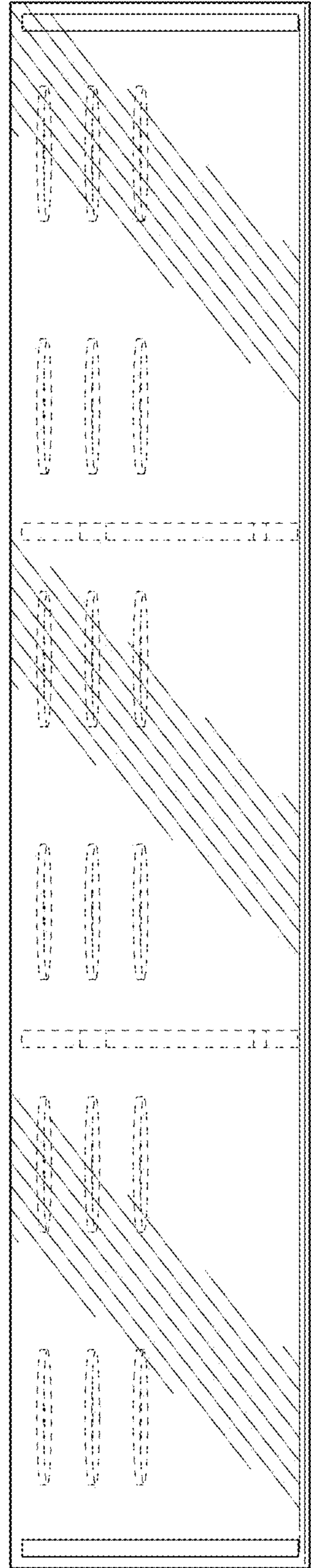

FIG. 3

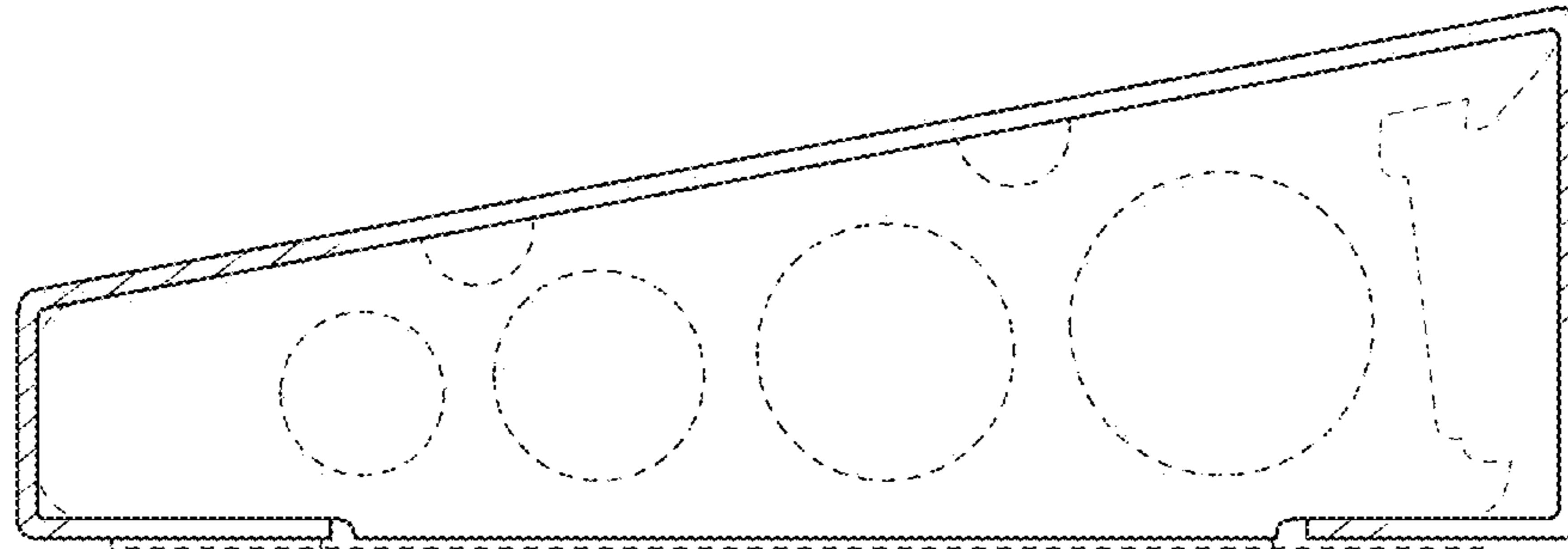

FIG. 4

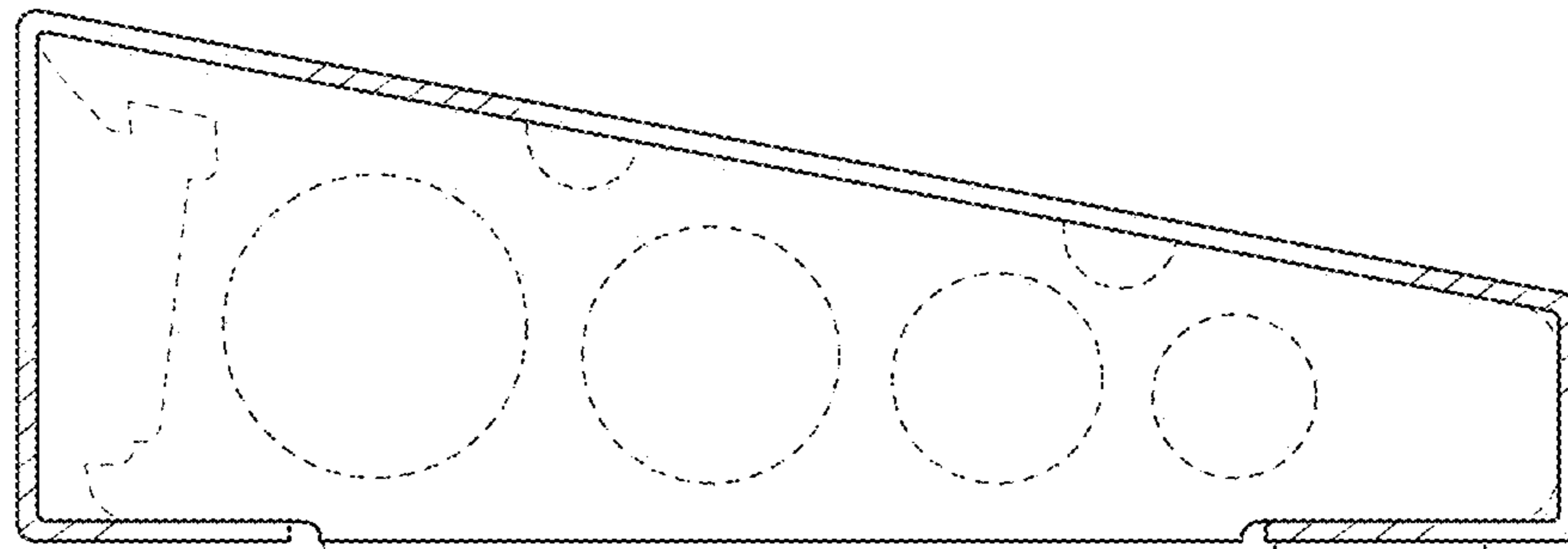

FIG. 5

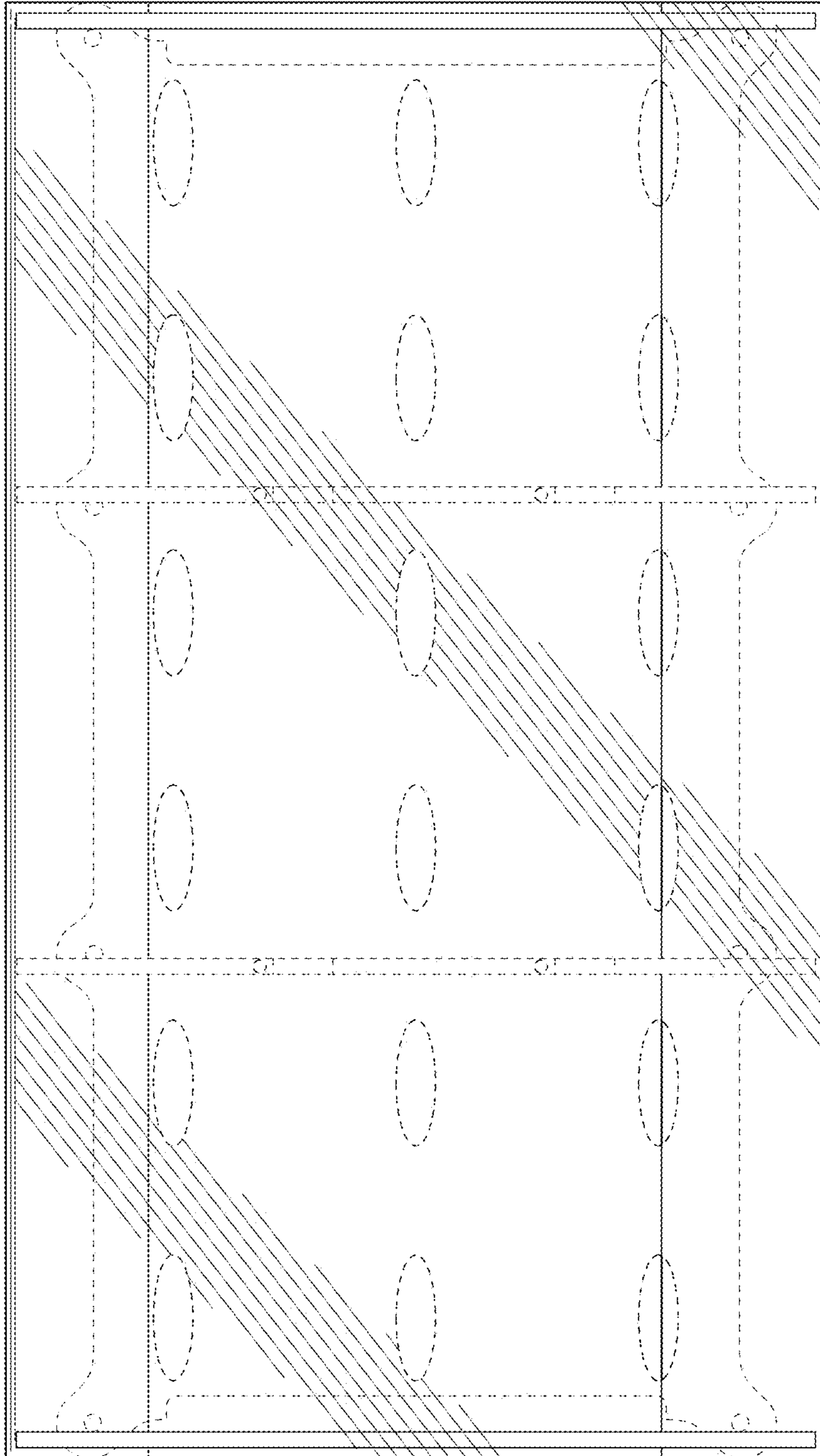

FIG. 6

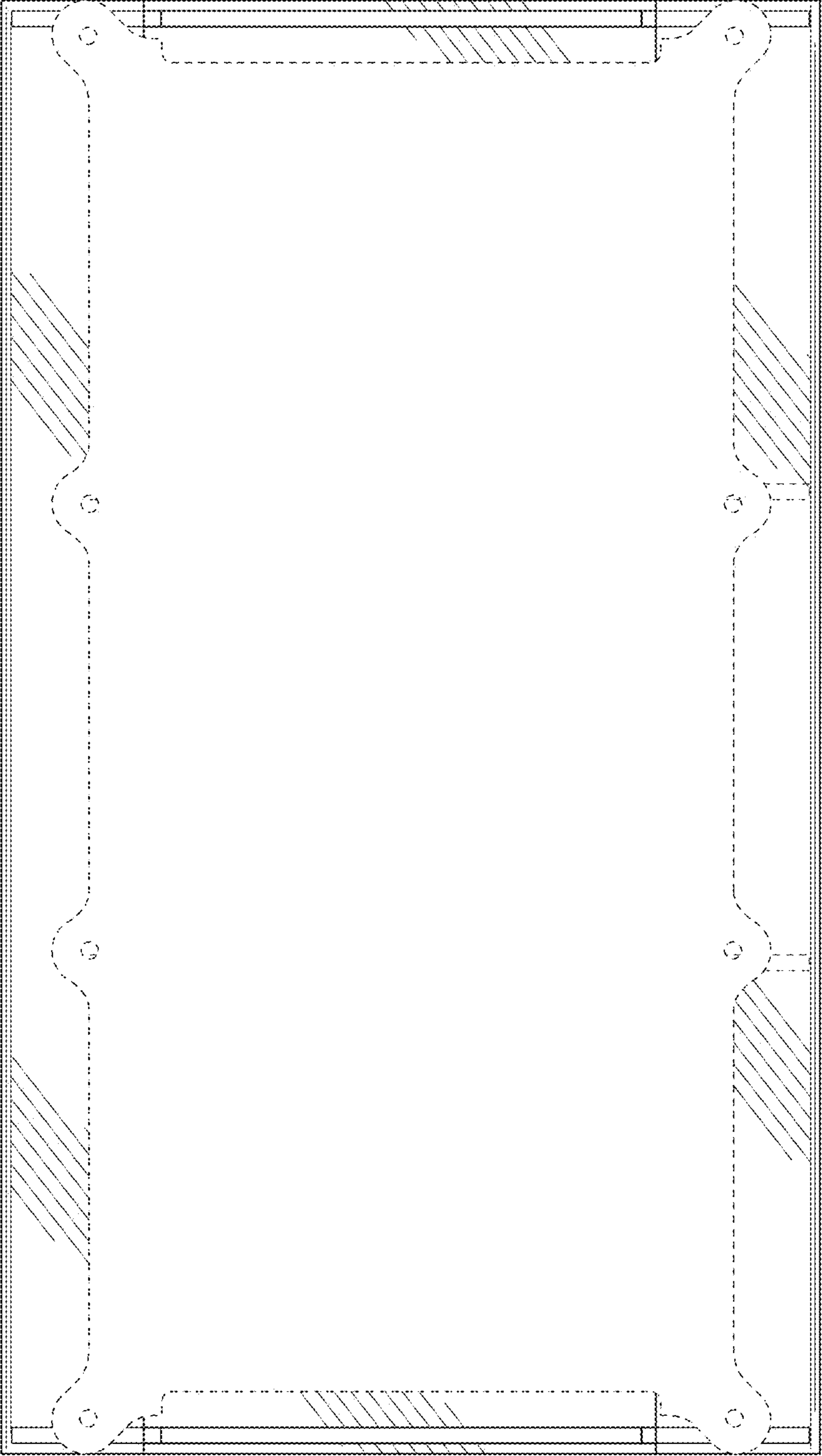

FIG. 7