



US00D929937S

(12) **United States Design Patent**
Zhang et al.

(10) **Patent No.:** **US D929,937 S**
(45) **Date of Patent:** **** Sep. 7, 2021**

(54) **POWER MODULE OF A FREQUENCY CONVERTER**

(71) Applicant: **SIEMENS AKTIENGESELLSCHAFT**, Munich (DE)

(72) Inventors: **An Chao Zhang**, Nanjing (CN); **Jiang Hai Xu**, Nanjing (CN); **Long Xian Ni**, Nanjing (CN); **Wen Chao Qu**, Nanjing (CN); **Jian Zhang**, Nanjing (CN)

(73) Assignee: **SIEMENS AKTIENGESELLSCHAFT**, Munich (DE)

(**) Term: **15 Years**

(21) Appl. No.: **29/696,920**

(22) Filed: **Jul. 2, 2019**

(30) **Foreign Application Priority Data**

Jan. 3, 2019 (CN) 201930002140.6

(51) **LOC (13) Cl.** **13-02**

(52) **U.S. Cl.**
USPC **D13/110**

(58) **Field of Classification Search**
USPC D13/103, 106, 107, 108, 109, 110, 112, D13/116, 118, 119, 123, 124, 125, 184; D14/302, 432
CPC H02M 7/00; H02M 7/42; H02P 27/04
See application file for complete search history.

(56) **References Cited**

U.S. PATENT DOCUMENTS

D673,910 S * 1/2013 Lostun D13/110
D685,733 S * 7/2013 Savolainen D13/110
D706,215 S * 6/2014 Nakahira D13/110

D772,161 S * 11/2016 Saarivirta D13/110
D775,072 S * 12/2016 Reiner D13/110
D804,416 S * 12/2017 Dilley D13/110
D811,327 S * 2/2018 Mueller D13/110

(Continued)

OTHER PUBLICATIONS

“Frequency Converter”. Found online Oct. 9, 2020 at eblogbd.com. Reference dated Nov. 14, 2013. Retrieved from https://eblogbd.com/starting-methods-of-motor/. (Year: 2013).*

(Continued)

Primary Examiner — Kendra Leslie Hamilton

Assistant Examiner — Amanda Christensen

(74) *Attorney, Agent, or Firm* — Henry M. Feiereisen LLC

(57) **CLAIM**

The ornamental design for a power module of a frequency converter, as shown and described.

DESCRIPTION

The patent or application file contains at least one drawing executed in color. Copies of this patent or patent application publication with color drawing(s) will be provided by the Office upon request and payment of the necessary fee.

FIG. 1 is a top, front, left side perspective view of a power module of a frequency converter, showing our new design; FIG. 2 is a bottom, rear, right side perspective view thereof; FIG. 3 is a top plan view thereof; FIG. 4 is a bottom plan view thereof; FIG. 5 is a left side elevation view thereof; FIG. 6 is a right side elevation view thereof; FIG. 7 is a rear elevation view thereof; and, FIG. 8 is a front elevation view thereof.

The equal length broken lines in the drawings depict portions of the power module for a frequency converter that form no part of the claimed design.

1 Claim, 8 Drawing Sheets
(5 of 8 Drawing Sheet(s) Filed in Color)

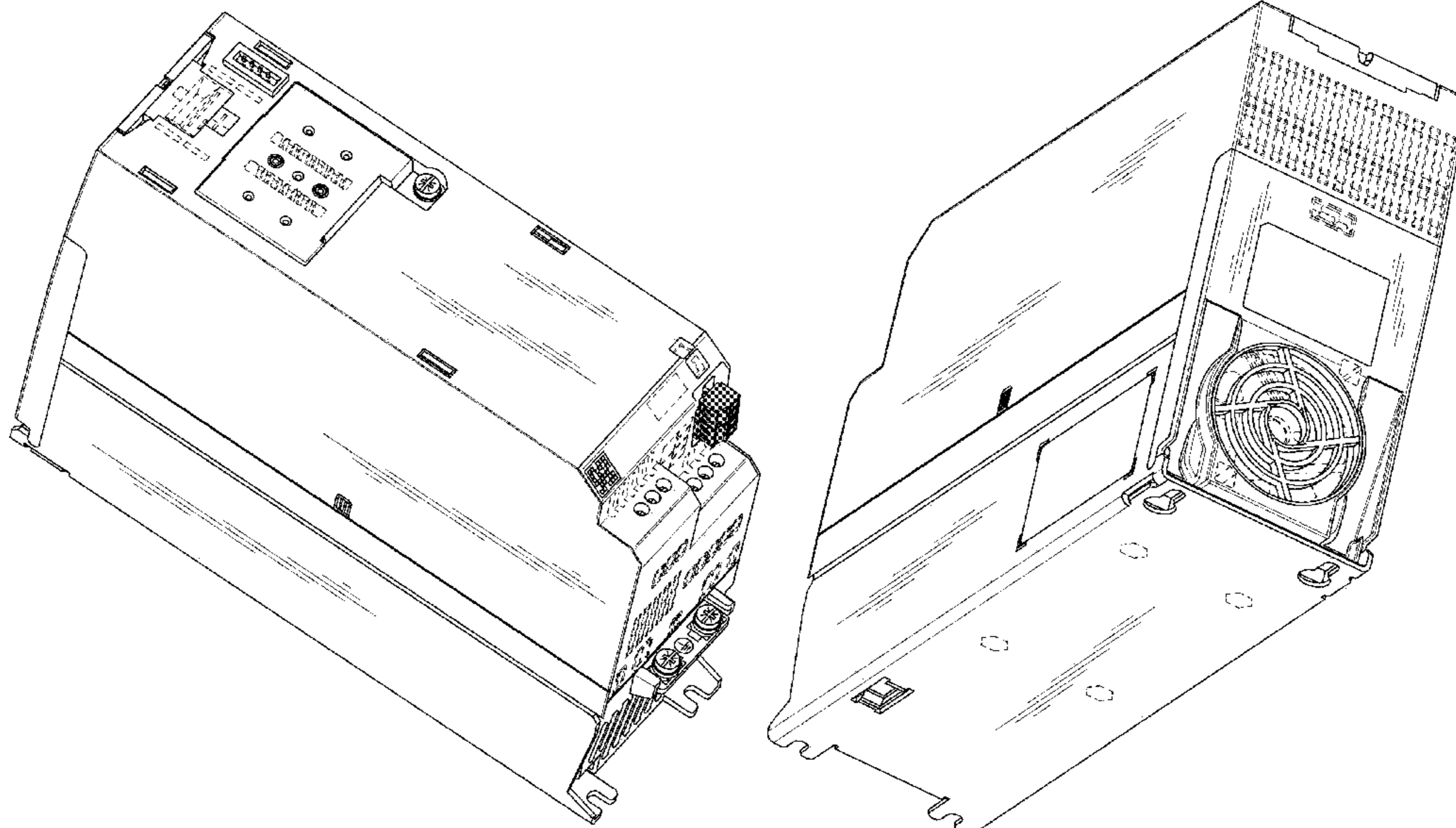

(56)

References Cited

U.S. PATENT DOCUMENTS

D819,565 S * 6/2018 Baacke D13/110
D842,808 S * 3/2019 Chen D13/110
D851,592 S * 6/2019 Poikolainen D13/123
2014/0084837 A1* 3/2014 Tio H02P 23/0031
318/519
2018/0279501 A1* 9/2018 Kodama H05K 7/20918
2020/0008324 A1* 1/2020 Kwon H05K 7/20909

OTHER PUBLICATIONS

“Siemens Frequency Drive”. Found online Oct. 9, 2020 at drivesandautomation.com. Reference dated Aug. 8, 2019. Retrieved from https://tineye.com/search/140a8095ca2aa53019f79501c13cda0051fb2b4a?sort=crawl_date&order=asc&page=1. (Year: 2019).*

“Siemens Low Voltage Converter”. Found online Oct. 9, 2020 at materialsupplieshk.com. Reference dated Oct. 18, 2017. Retrieved from https://tineye.com/search/6d56aeeba85a14a4073d76db82ba239e7b433d9e?sort=crawl_date&order=asc&page=1. (Year: 2017).*

* cited by examiner

FIG. 1

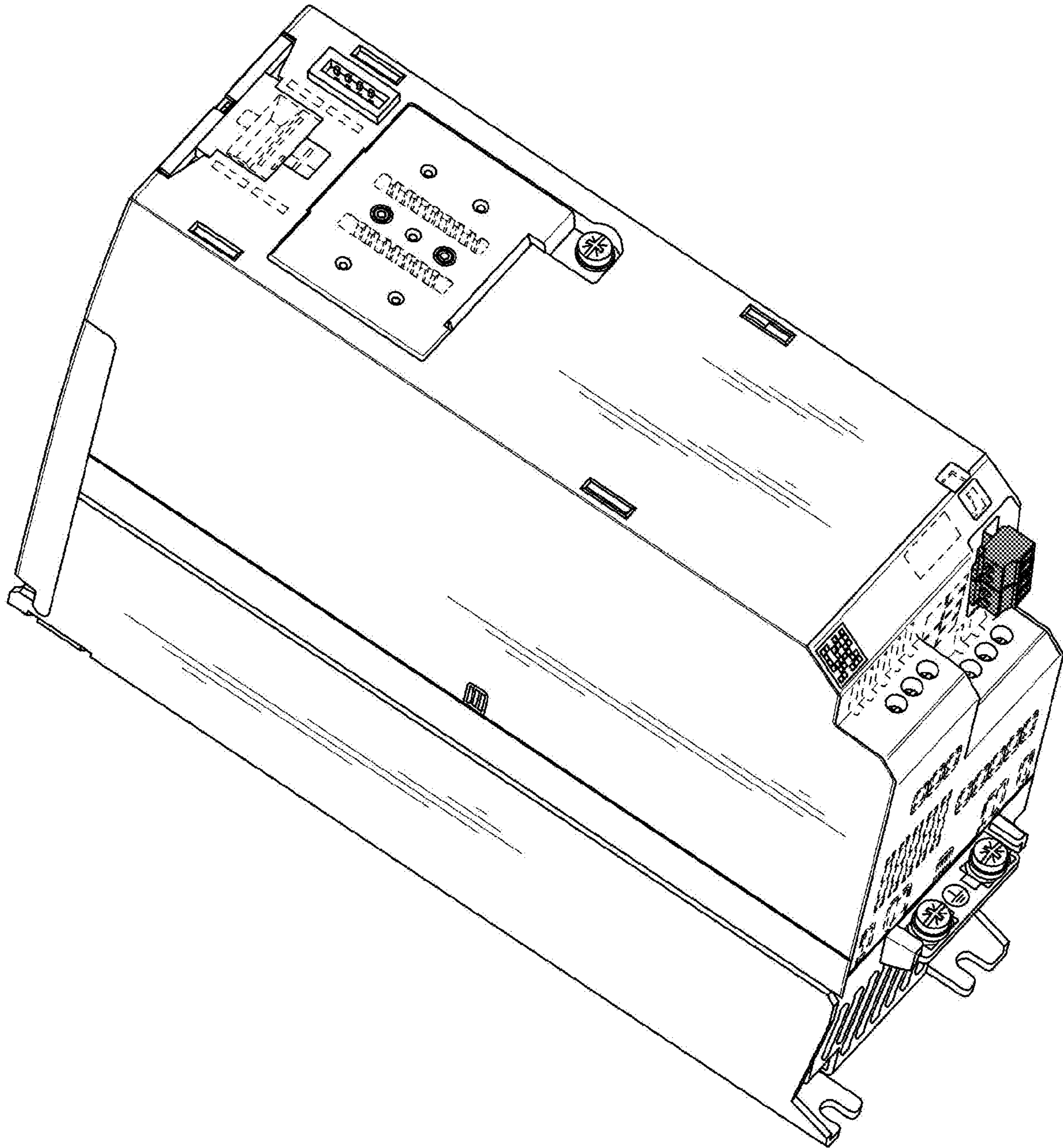

FIG. 2

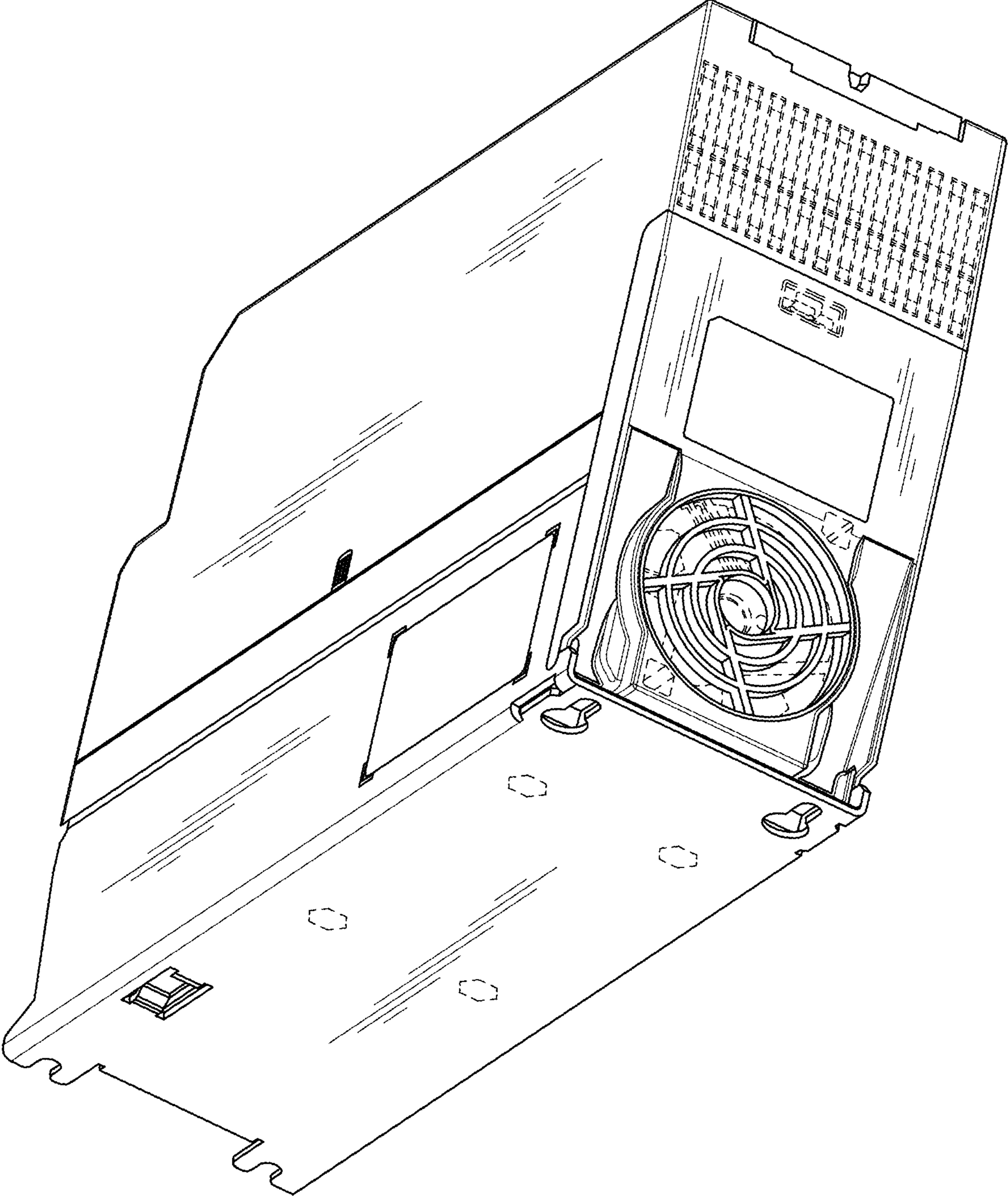

FIG. 3

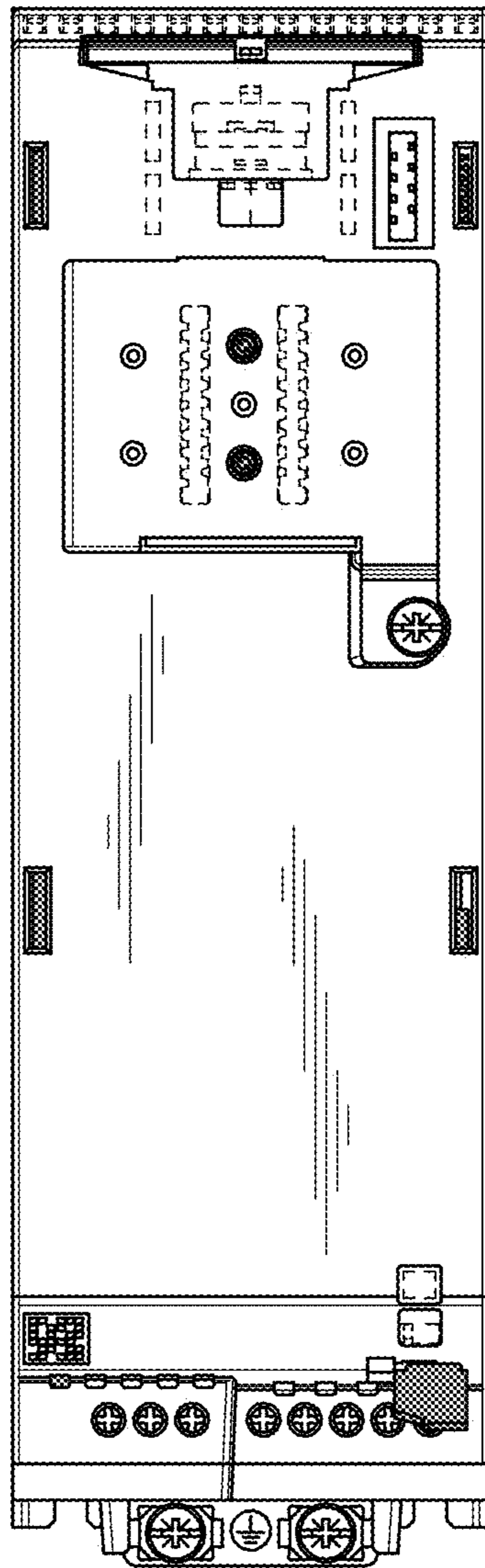

FIG. 4

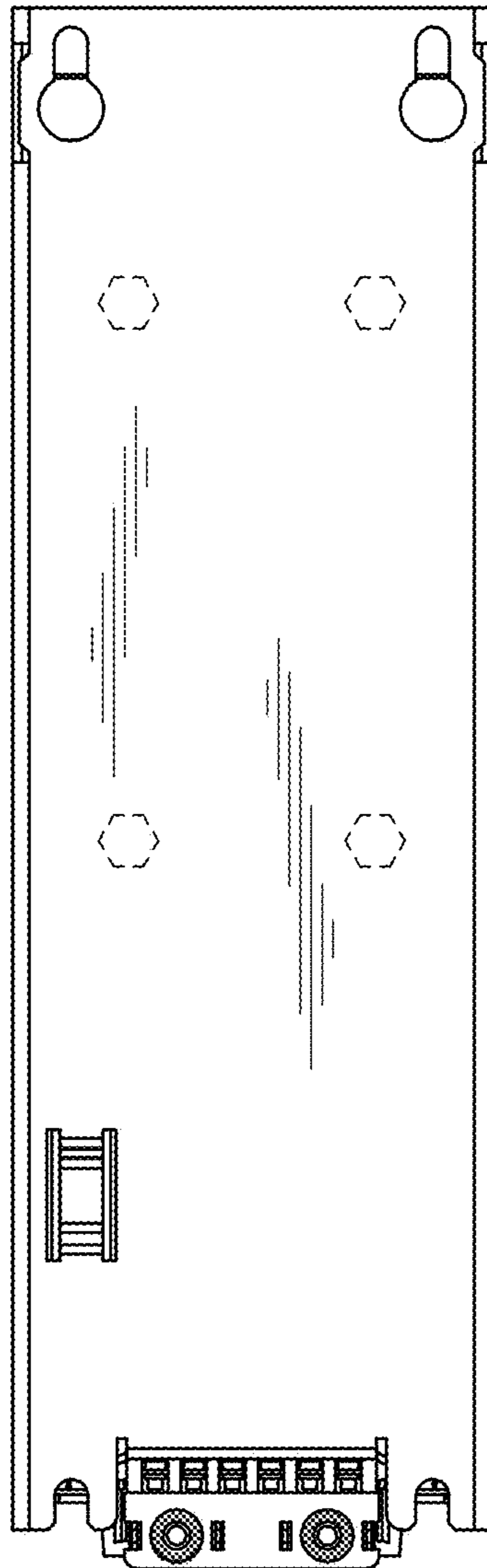

FIG. 5

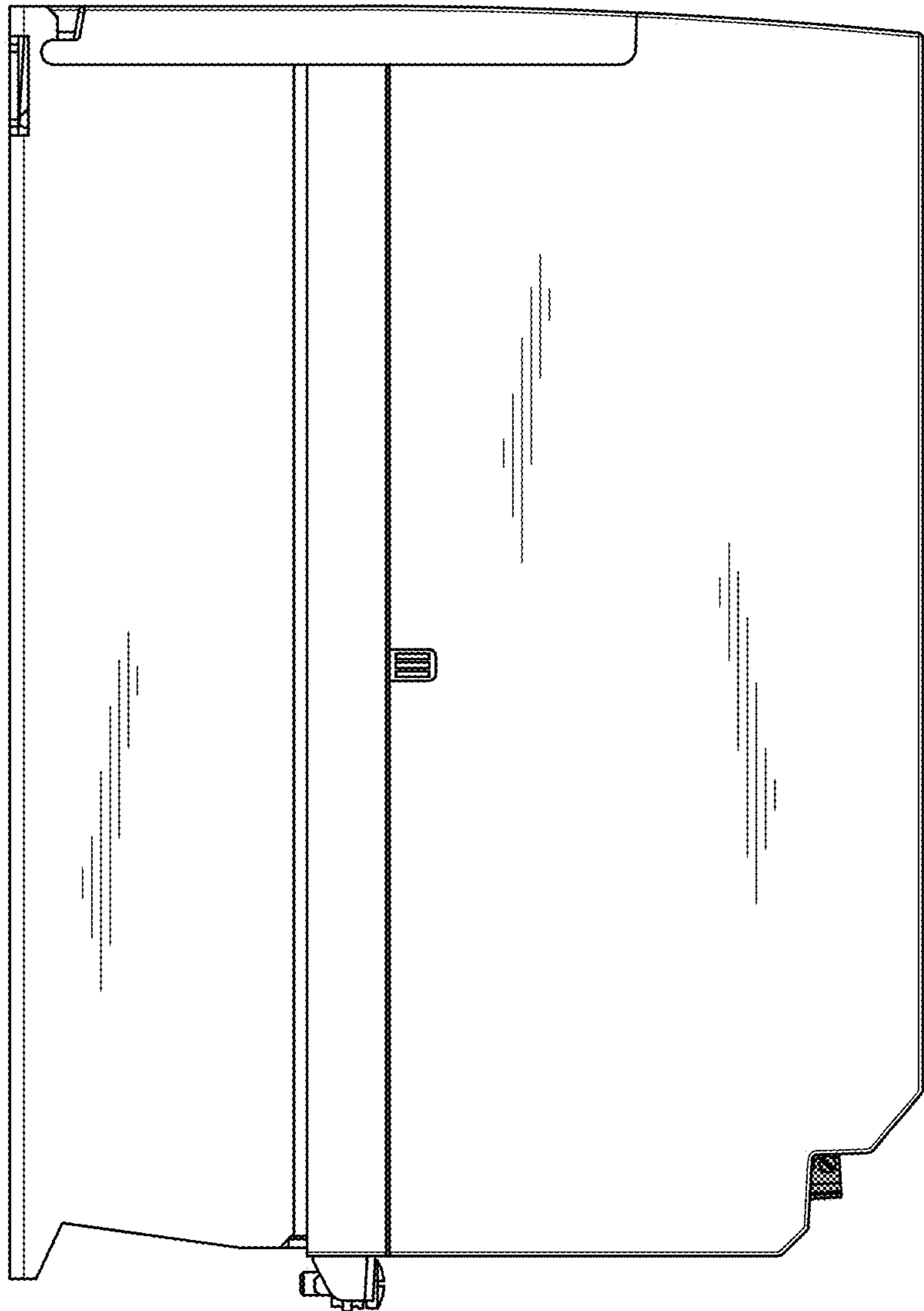

FIG. 6

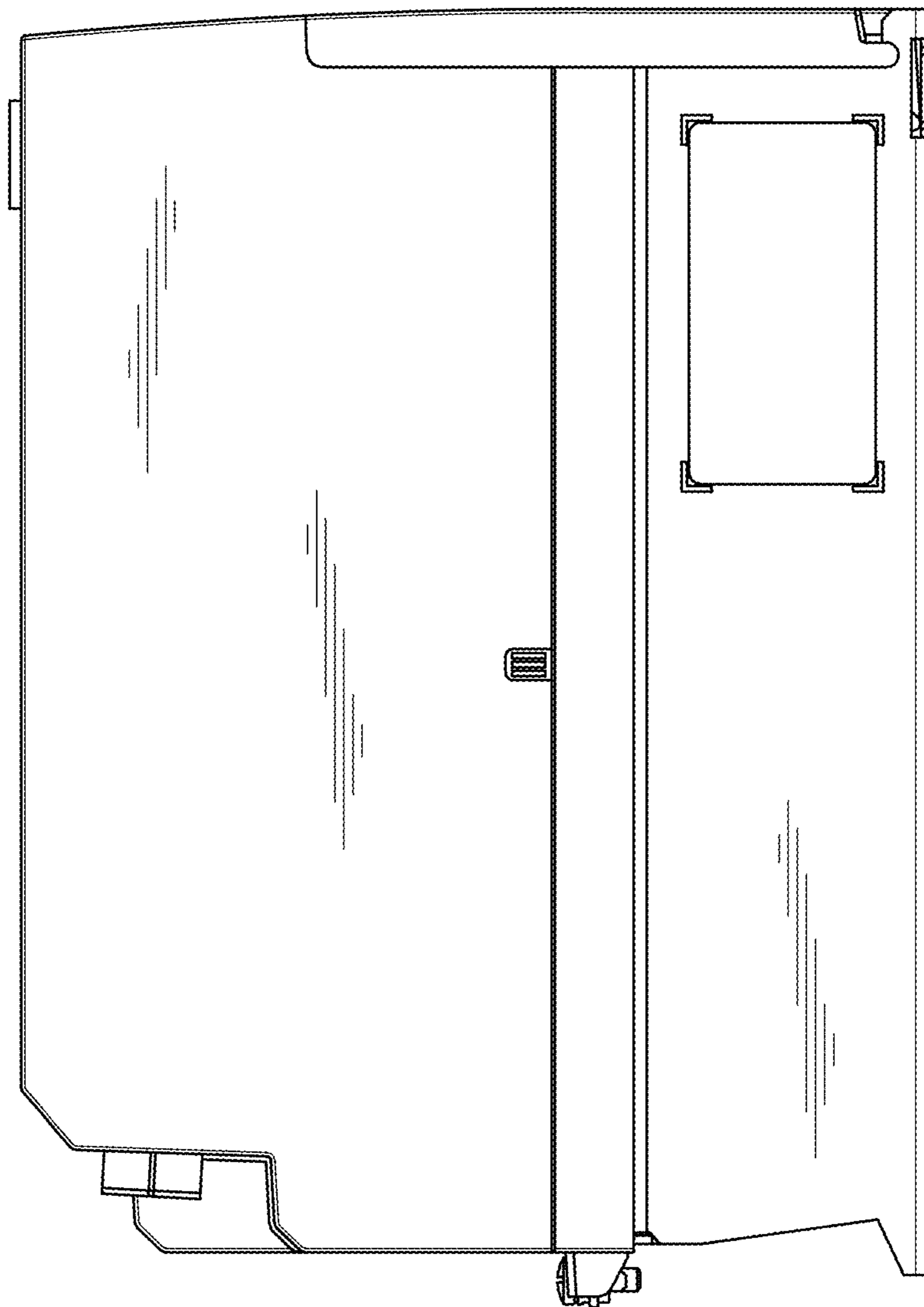

FIG. 7

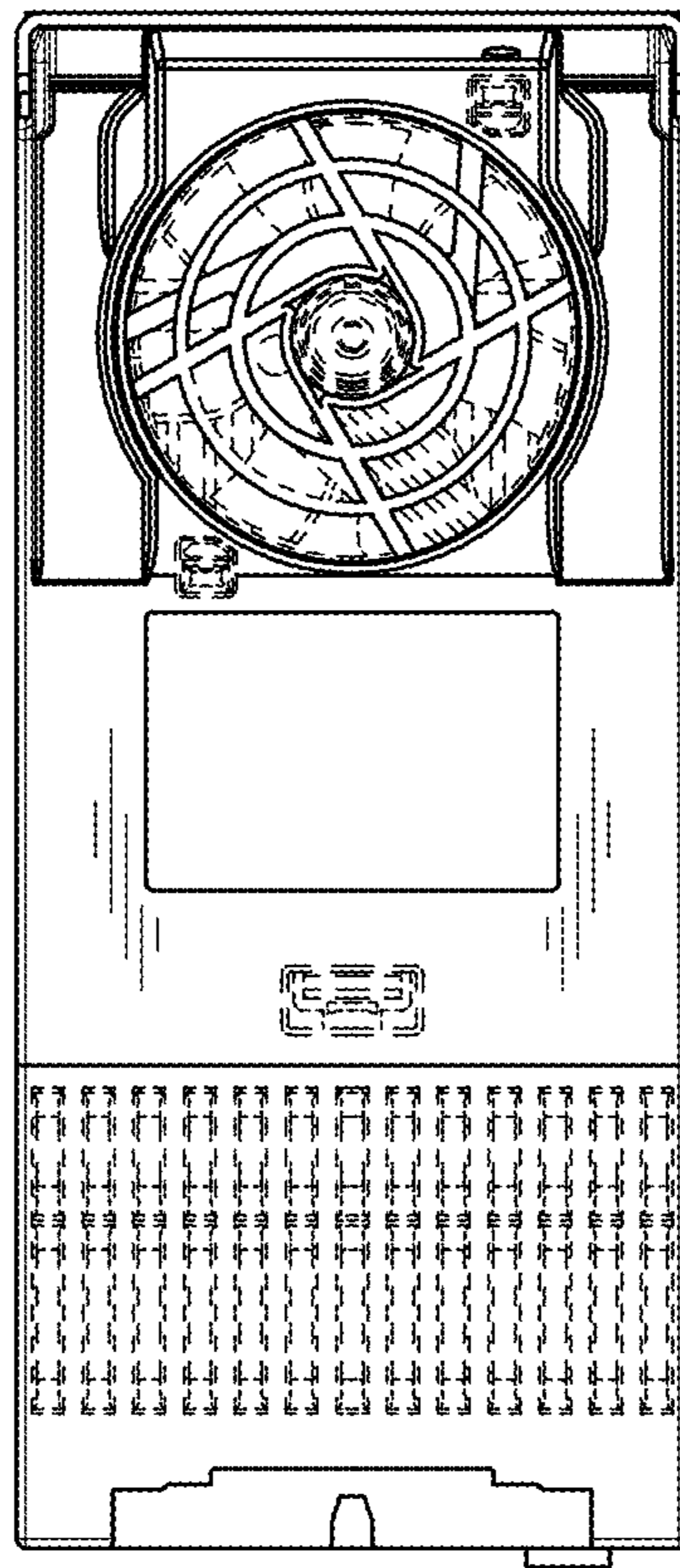

FIG. 8

