



US00D929531S

(12) **United States Design Patent** (10) **Patent No.:** **US D929,531 S**  
**Schellaars** (45) **Date of Patent:** **\*\* Aug. 31, 2021**

(54) **TANK ASSEMBLY FOR FIRE SUPPRESSION**

D699,813 S \* 2/2014 Vogt ..... D23/202  
D768,261 S \* 10/2016 Martin ..... D23/202  
2010/0224542 A1 \* 9/2010 Arita ..... C02F 3/2806  
210/167.22

(71) Applicant: **Helitak Fire Fighting Equipment Pty Ltd, Noosaville (AU)**

(72) Inventor: **Jason Schellaars, Noosaville (AU)**

(\*\*) Term: **15 Years**

(21) Appl. No.: **29/693,436**

(22) Filed: **Jun. 3, 2019**

(51) **LOC (13) Cl.** ..... **23-01**

(52) **U.S. Cl.**  
USPC ..... **D23/202**

(58) **Field of Classification Search**  
USPC ..... D23/200–205, 210  
CPC ..... A01K 63/04  
See application file for complete search history.

(56) **References Cited**

**U.S. PATENT DOCUMENTS**

2,507,939 A \* 5/1950 Smith ..... A62C 8/005  
220/666  
2,749,956 A \* 6/1956 Eldred ..... B65D 90/205  
220/9.3  
D294,172 S \* 2/1988 Willinger ..... D23/210  
5,266,190 A \* 11/1993 Tominaga ..... A01K 63/045  
119/259  
6,106,709 A \* 8/2000 Bresolin ..... A01K 63/045  
119/259  
D441,829 S \* 5/2001 Wang ..... D23/210  
D473,282 S \* 4/2003 Lin ..... D23/210  
D505,711 S \* 5/2005 Wu ..... D23/210  
D520,104 S \* 5/2006 Wang ..... D23/210  
D650,041 S \* 12/2011 Wu ..... D23/210  
D650,468 S \* 12/2011 Wang ..... D23/210

**OTHER PUBLICATIONS**

Helicopter fire tank, posted Jan. 10, 2007 [online], [retrieved Nov. 17, 2020]. Retrieved from internet, <https://www.youtube.com/watch?v=WGBWG5ET3V8> (on or around timestamp 0:21 into the video) (Year: 2007).\*

Helitak Fire Tank, announced date unavailable[online], [site visited Nov. 18, 2020]. Available from internet, URL:<<https://helitak.com.au/helitak-fire-tank/>> (Year: 2020).\*

\* cited by examiner

*Primary Examiner* — Barbara Fox

*Assistant Examiner* — Jamaal Rasheed

(74) *Attorney, Agent, or Firm* — Williams Intellectual Property; Benjamin F. Williams

(57) **CLAIM**

The ornamental design for a tank assembly for fire suppression, as shown and described.

**DESCRIPTION**

FIG. 1 is a perspective view of a tank assembly for fire suppression, showing my new design; FIG. 2 is a front elevation view; FIG. 3 is left side elevation view; FIG. 4 is a right side elevation view; FIG. 5 is a top elevation view; and, FIG. 6 is a bottom elevation view.

The broken lines shown in the drawings depict portions of the tank assembly for fire suppression that form no part of the claimed design.

**1 Claim, 6 Drawing Sheets**

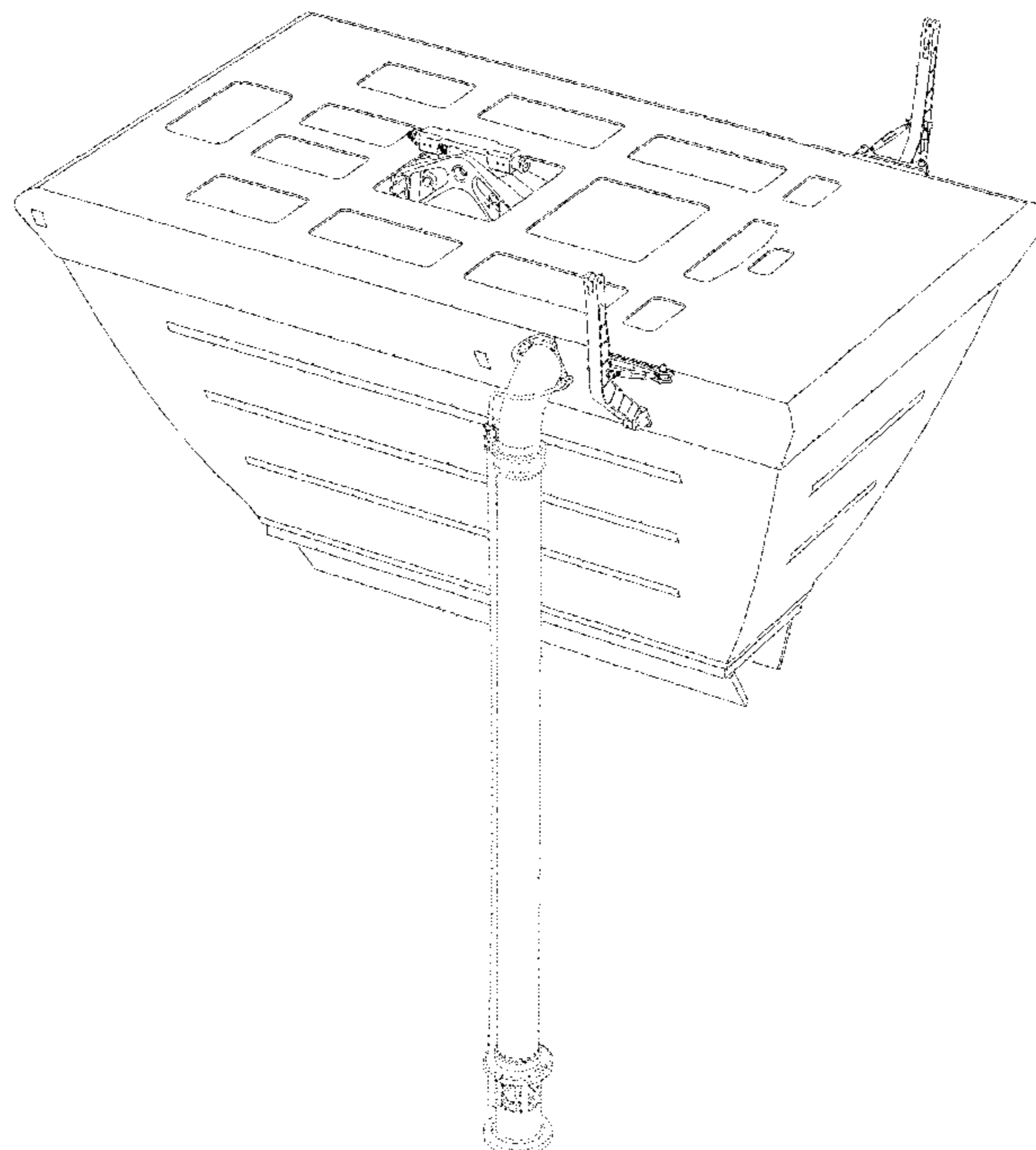

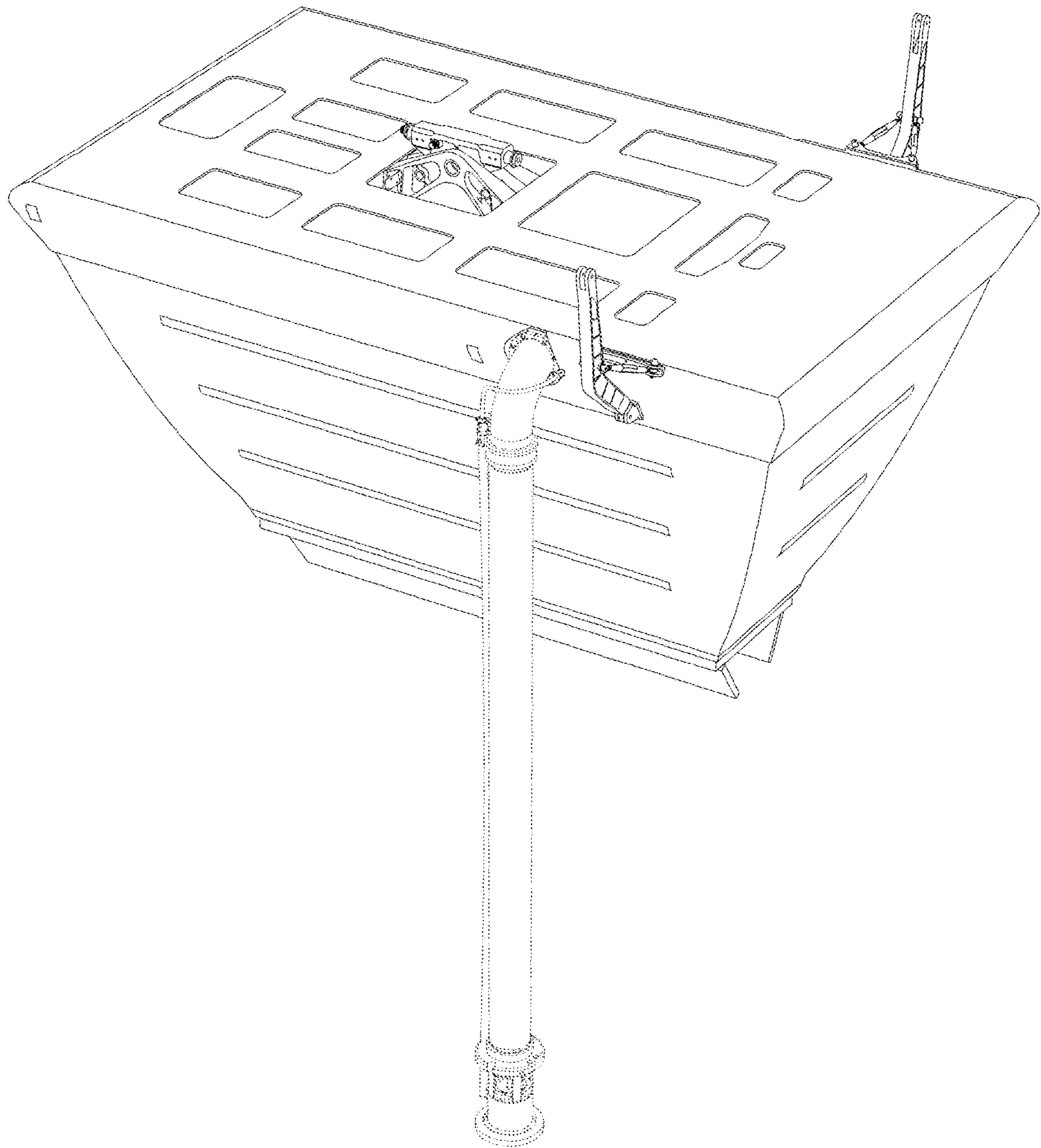

FIG. 1

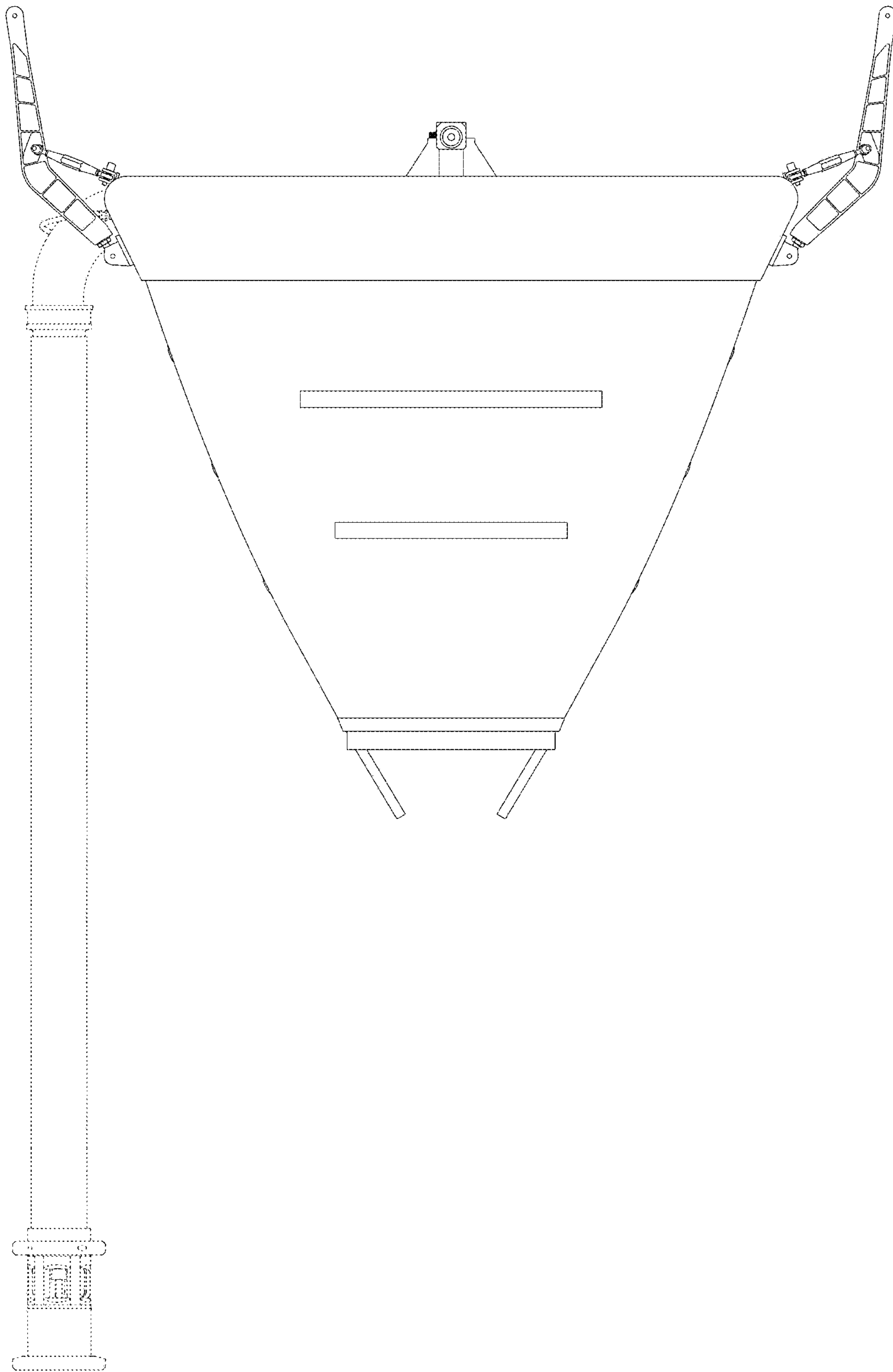

FIG. 2

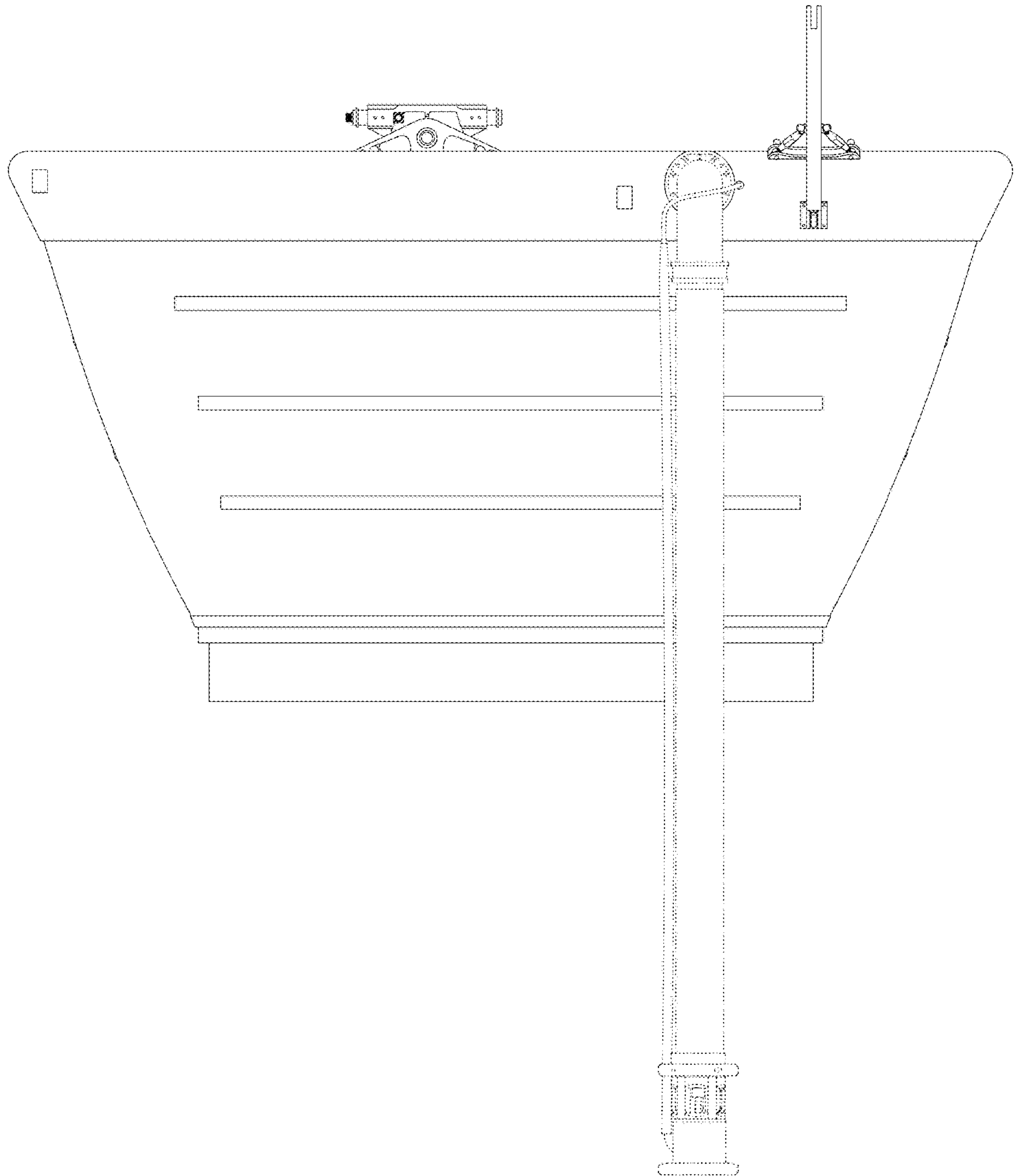

FIG. 3

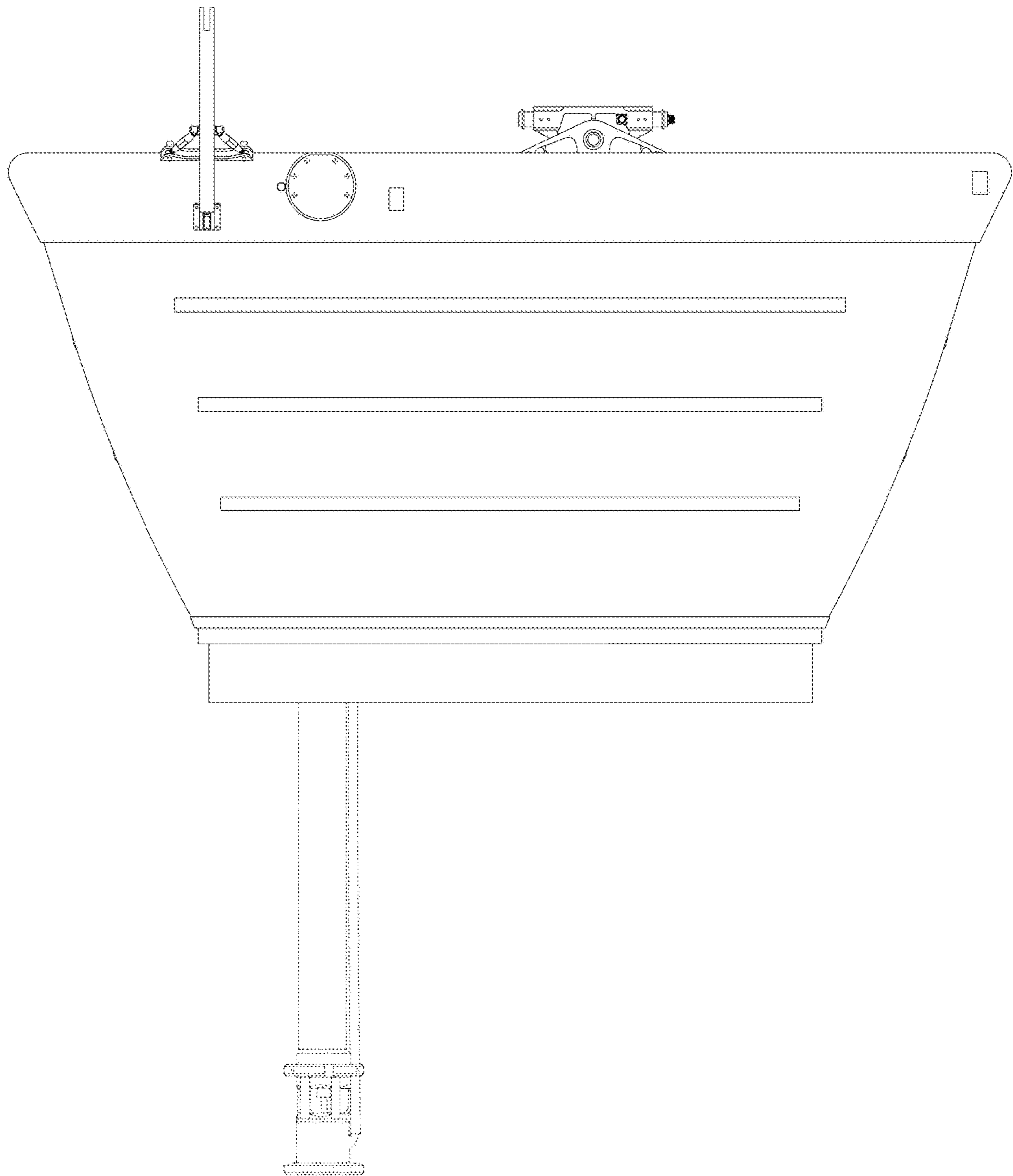

FIG. 4

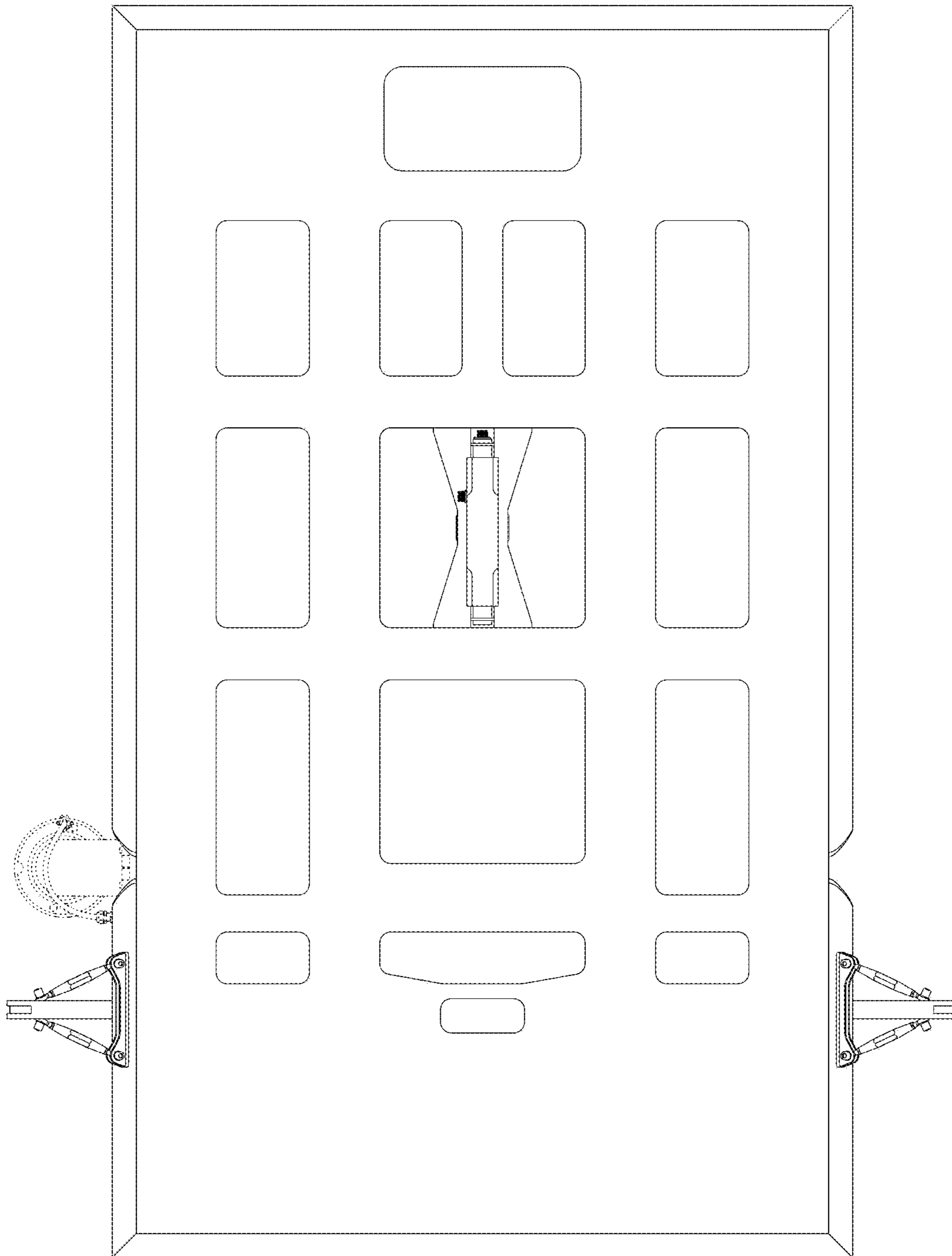

FIG. 5



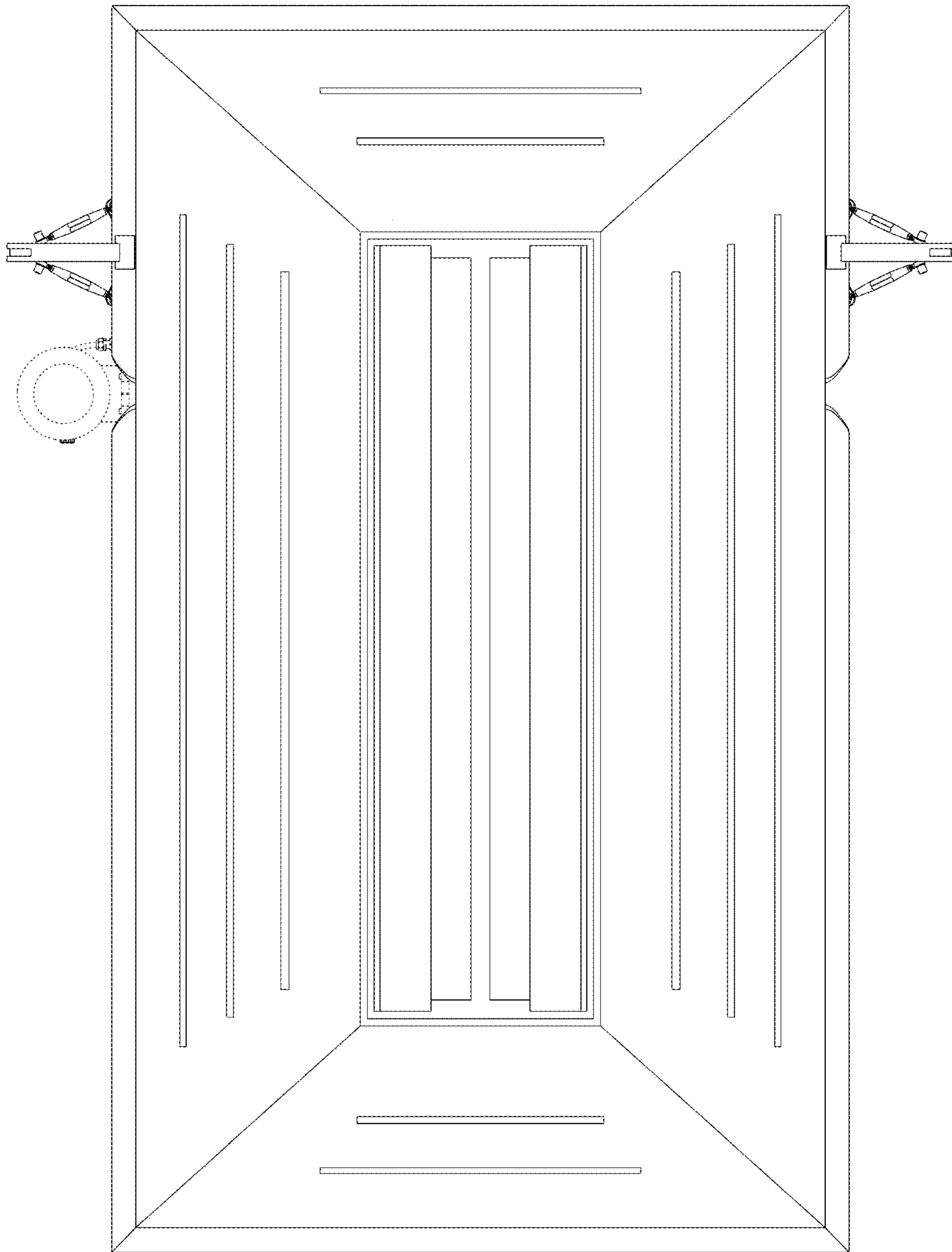

FIG. 6