



US00D929511S

(12) **United States Design Patent** (10) **Patent No.:** **US D929,511 S**  
**Chen** (45) **Date of Patent:** **\*\* Aug. 31, 2021**

(54) **TREADMILL**  
(71) Applicant: **SHENZHEN RIDETECH ELECTRONICS CO., LTD**, Shenzhen (CN)  
(72) Inventor: **Guoming Chen**, Shenzhen (CN)  
(73) Assignee: **SHENZHEN RIDETECH ELECTRONICS CO., LTD**, Shenzhen (CN)  
(\*\*) Term: **15 Years**  
(21) Appl. No.: **29/715,184**  
(22) Filed: **Nov. 28, 2019**  
(51) **LOC (13) Cl.** ..... **21-02**  
(52) **U.S. Cl.**  
USPC ..... **D21/669**  
(58) **Field of Classification Search**  
USPC ..... D21/669, 800, 662, 668, 670, 671, 694  
See application file for complete search history.

(56) **References Cited**  
U.S. PATENT DOCUMENTS  
D207,541 S \* 5/1967 Hesen ..... D21/669  
3,642,279 A \* 2/1972 Cutter ..... A63B 22/02  
482/54  
3,650,529 A \* 3/1972 Salm ..... A63B 22/02  
482/54  
4,151,988 A \* 5/1979 Nabinger ..... A63B 22/02  
188/72.9  
D280,002 S \* 8/1985 Smith ..... D21/669  
4,544,152 A \* 10/1985 Taitel ..... A63B 21/015  
188/187  
4,614,336 A \* 9/1986 Taitel ..... A63B 21/015  
482/54  
5,018,722 A \* 5/1991 Whitmore ..... A63B 22/02  
482/54  
D325,951 S \* 5/1992 Johnson ..... D21/669

D342,107 S \* 12/1993 Chang ..... D21/669  
D355,227 S \* 2/1995 Summers ..... D21/669  
D412,953 S \* 8/1999 Armstrong ..... D21/669  
D413,366 S \* 8/1999 Husted ..... D21/668  
D424,137 S \* 5/2000 Barker ..... D21/669  
D425,154 S \* 5/2000 Alessandri ..... D21/668  
6,174,267 B1 \* 1/2001 Dalebout ..... A63B 22/02  
482/51  
D437,371 S \* 2/2001 Webber ..... D21/686  
D484,554 S \* 12/2003 Hellman, Jr. .... D21/669  
D494,234 S \* 8/2004 Sporie ..... D21/669  
D613,353 S \* 4/2010 Bulva ..... D21/694  
D888,845 S \* 6/2020 Luo ..... D21/669  
D908,817 S \* 1/2021 Wang ..... D21/669  
D910,123 S \* 2/2021 Li ..... D21/669  
2009/0088301 A1 \* 4/2009 Alling ..... A63B 24/00  
482/54  
2012/0040802 A1 \* 2/2012 Dibble ..... A63B 22/02  
482/54

\* cited by examiner

*Primary Examiner* — Khawaja Anwar  
*Assistant Examiner* — Julice Seung Eun Oum

(57) **CLAIM**

The ornamental design for a treadmill, as shown and described.

**DESCRIPTION**

FIG. 1 is a front, top and right side perspective view of a treadmill, showing my new design;  
FIG. 2 is a front view thereof;  
FIG. 3 is a rear view thereof;  
FIG. 4 is a left side view thereof;  
FIG. 5 is a right side view thereof;  
FIG. 6 is a top plan view thereof; and,  
FIG. 7 is a bottom plan view thereof.  
The broken lines are for the purpose of illustrating portions of the article that form no part of the claimed design.

**1 Claim, 7 Drawing Sheets**

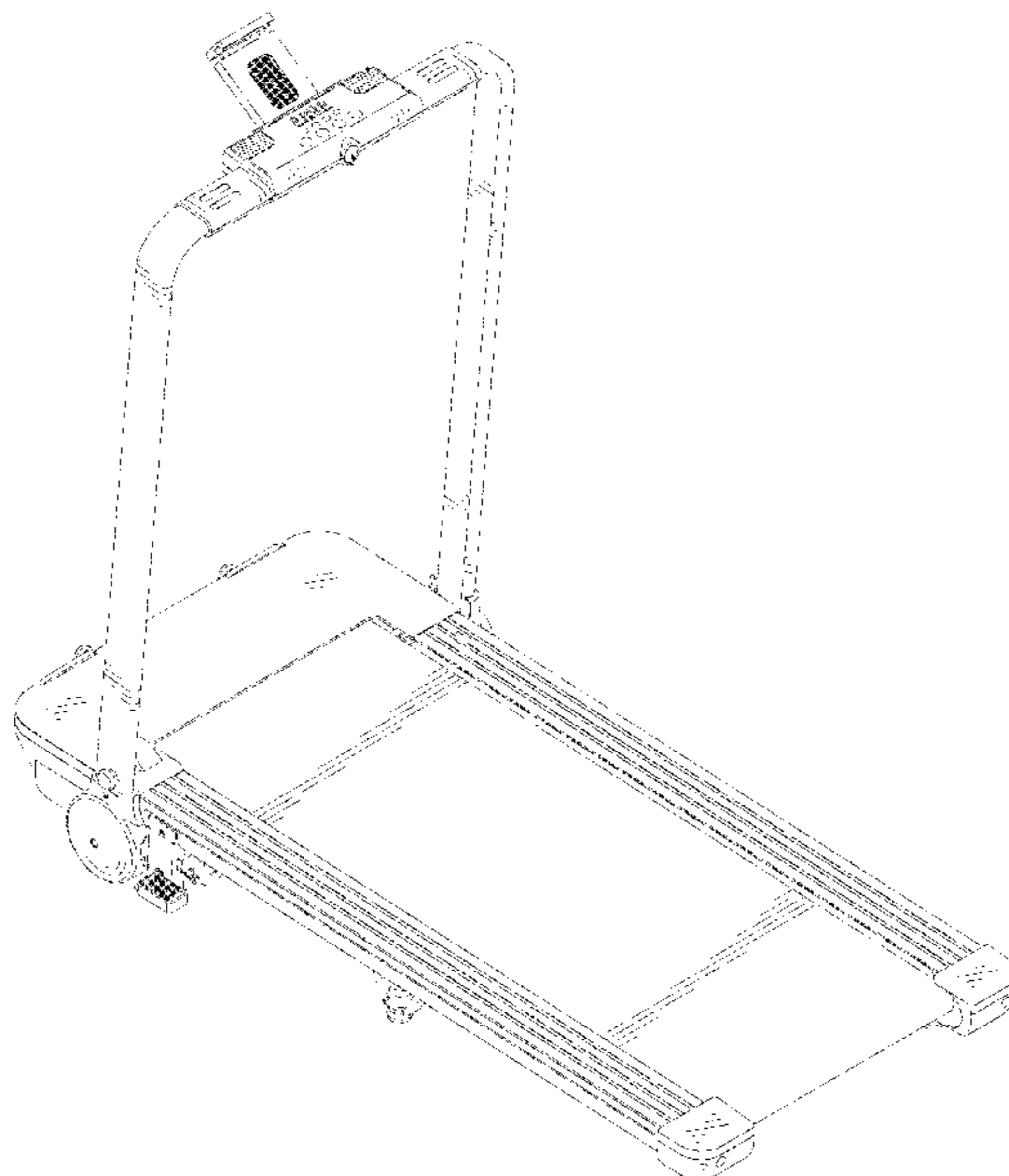

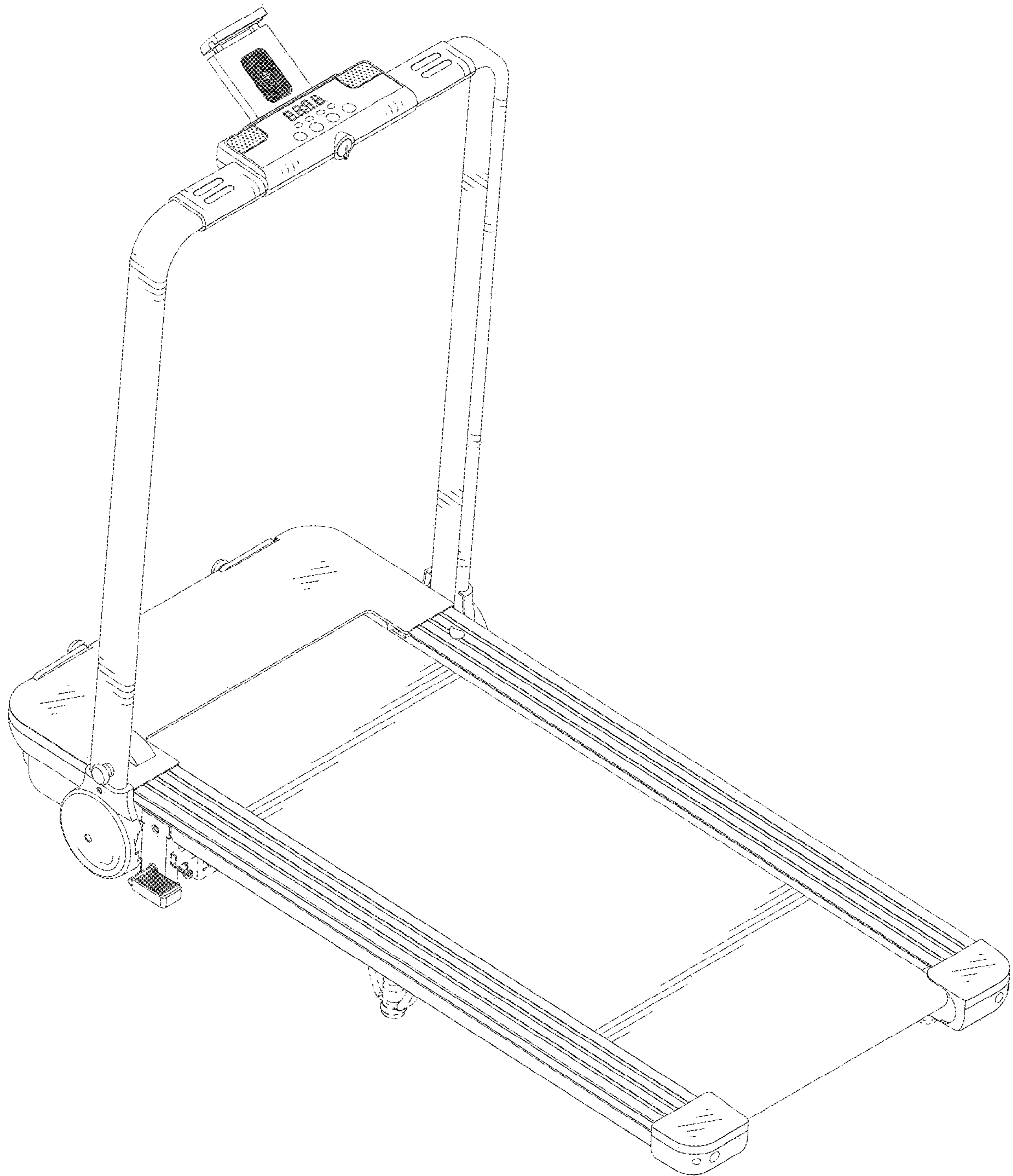

FIG. 1

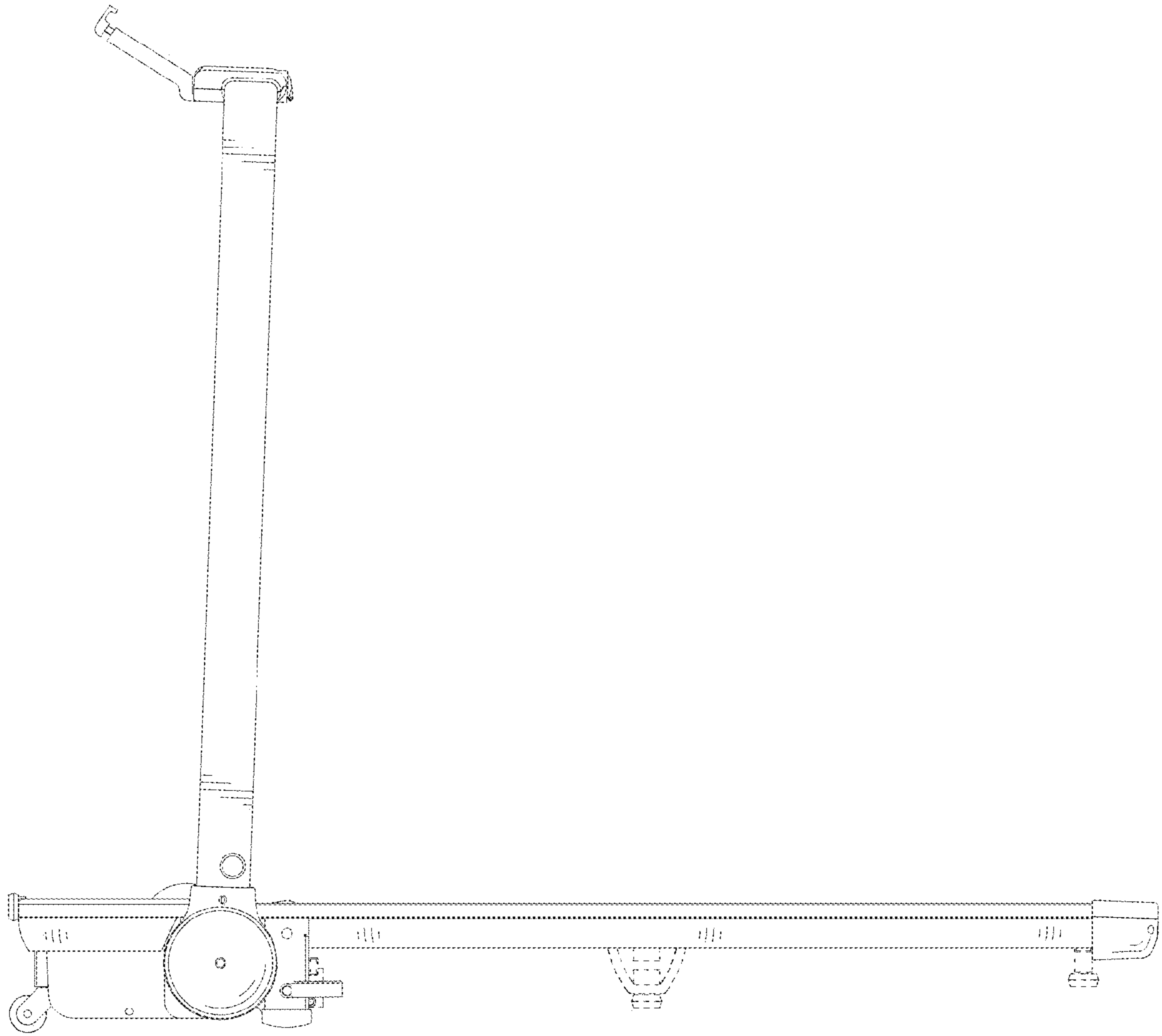

FIG. 2

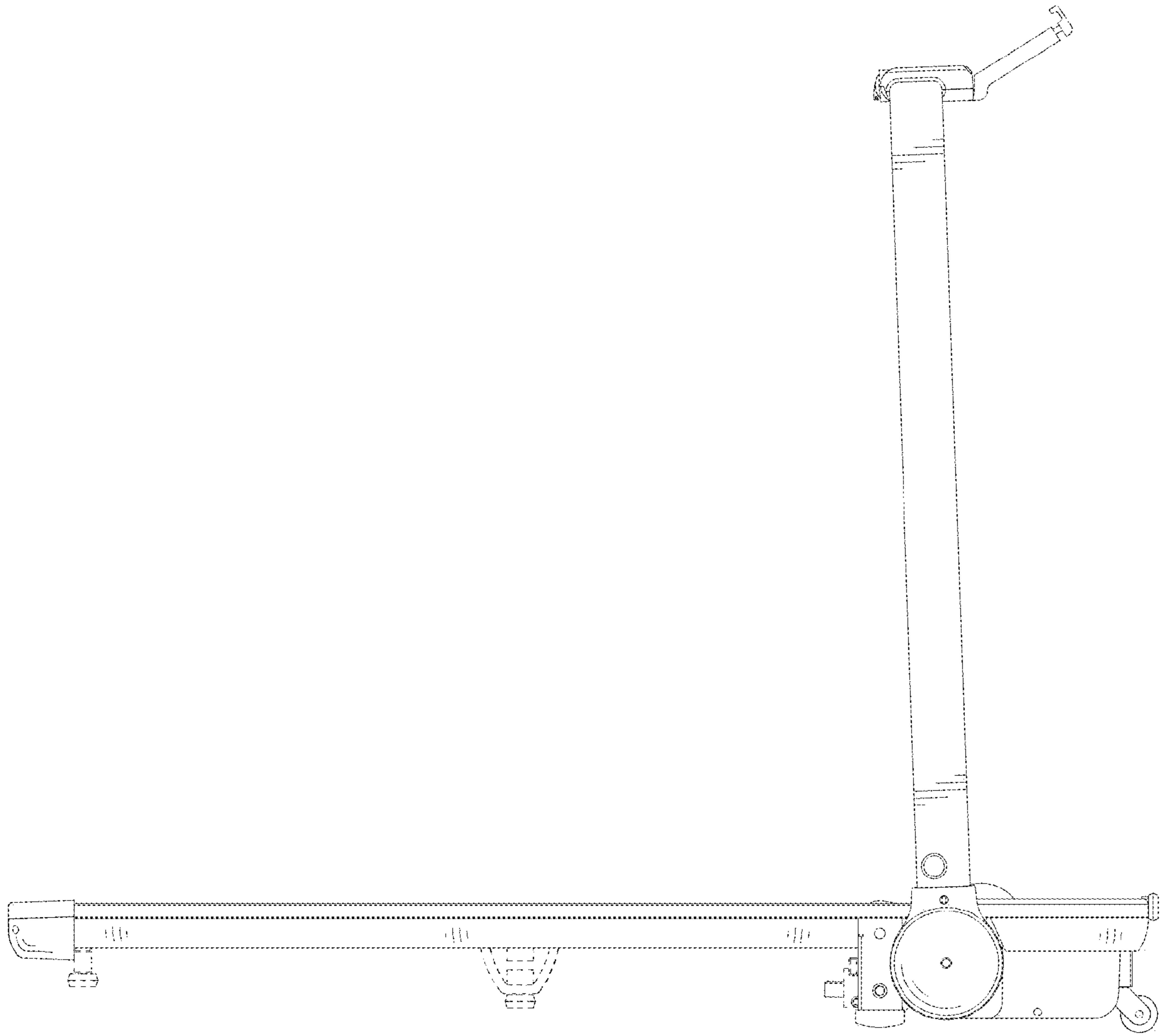

FIG. 3

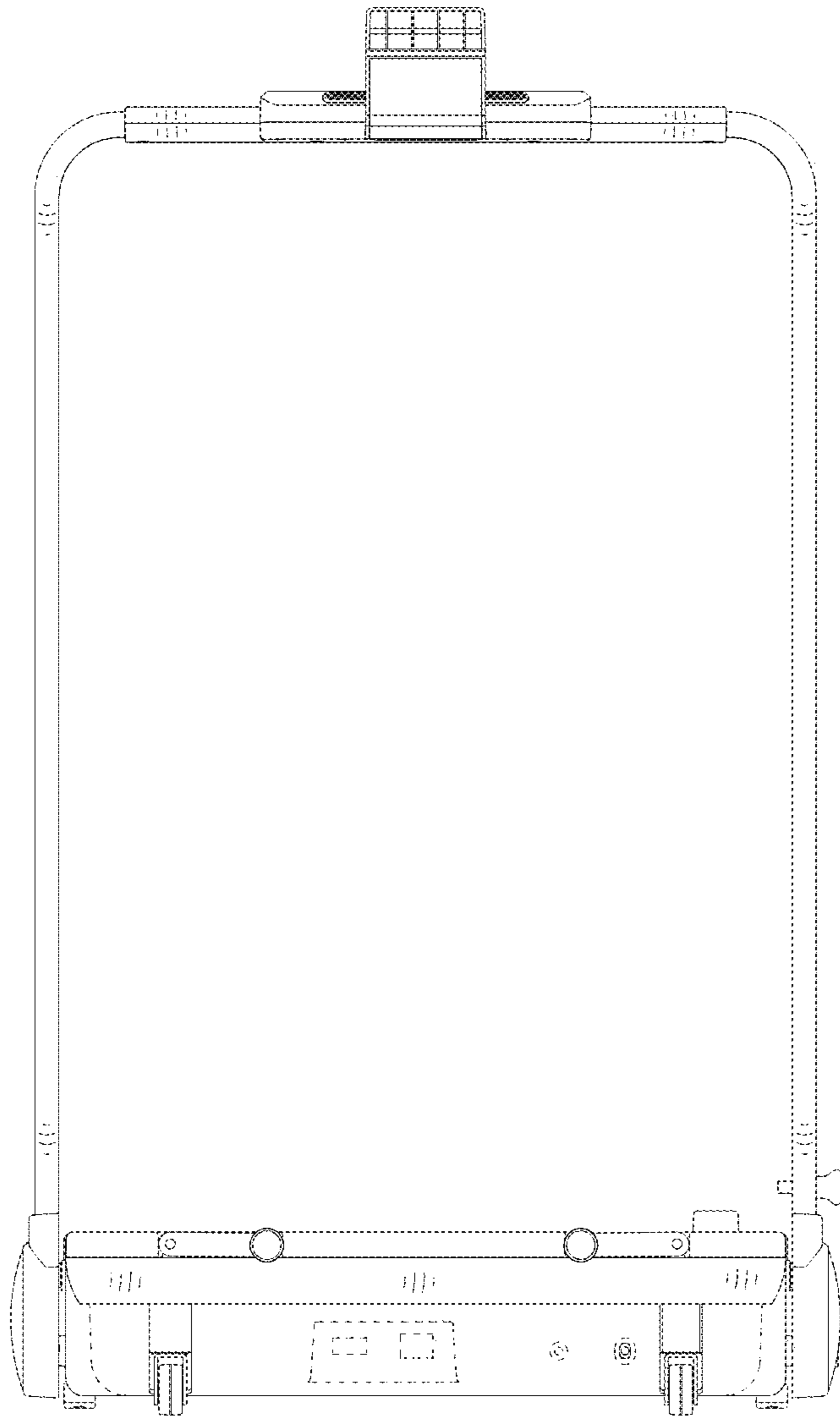

FIG. 4

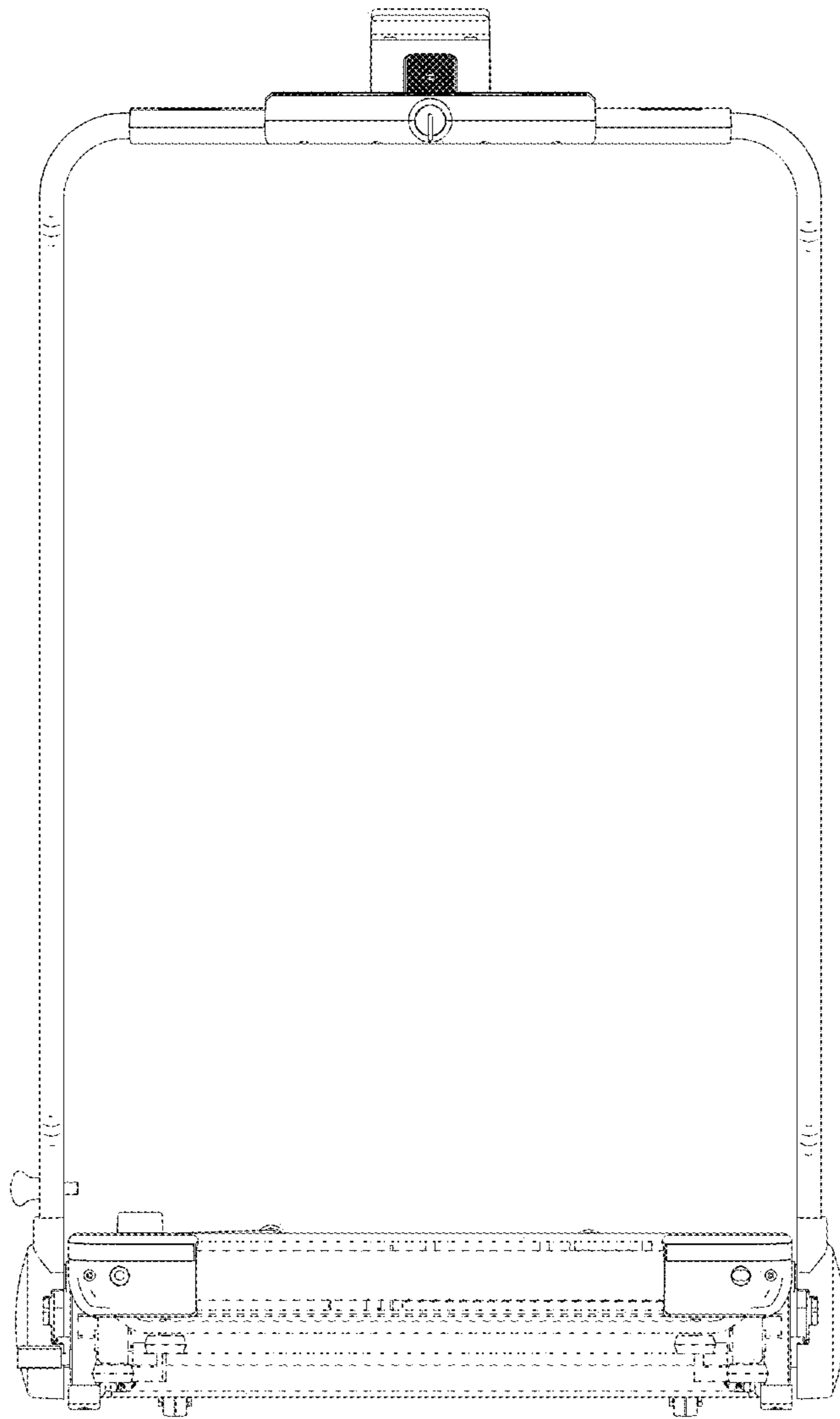

FIG. 5

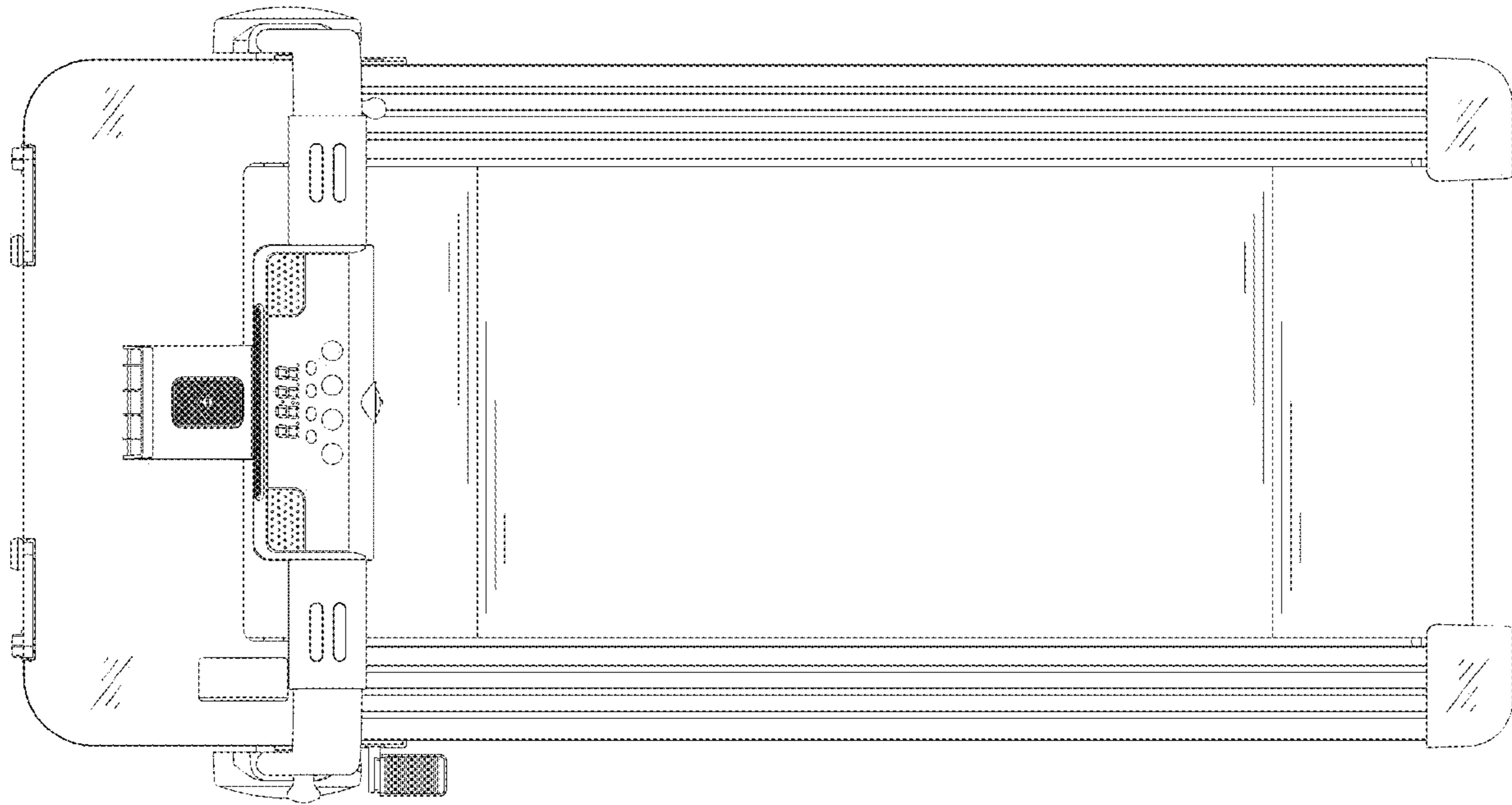

FIG. 6

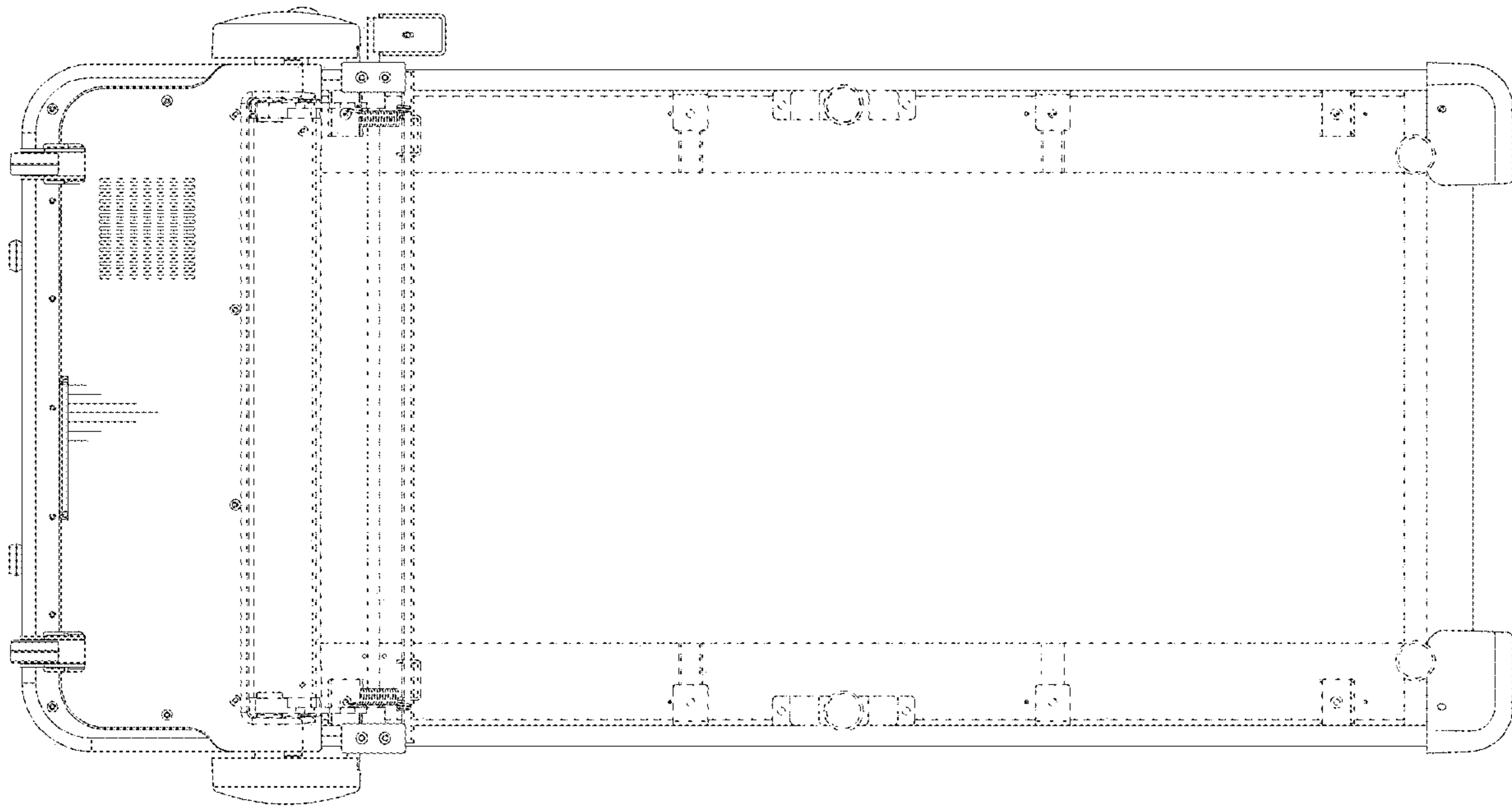

FIG. 7