



US00D929310S

(12) **United States Design Patent**  
**Kang et al.**

(10) **Patent No.:** **US D929,310 S**  
(45) **Date of Patent:** **\*\* Aug. 31, 2021**

(54) **AUTOMOBILE**

(71) Applicant: **LG Electronics Inc.**, Seoul (KR)

(72) Inventors: **Seungmo Kang**, Seoul (KR); **Romain Diboine**, Seoul (KR); **Juneho Song**, Seoul (KR); **Sewon Chun**, Seoul (KR)

(73) Assignee: **LG ELECTRONICS INC.**, Seoul (KR)

(\*\*) Term: **15 Years**

(21) Appl. No.: **35/509,372**

(22) Filed: **Oct. 16, 2019**

(80) **Hague Agreement Data**

Int. Filing Date: **Oct. 16, 2019**  
Int. Reg. No.: **DM/207855**  
Int. Reg. Date: **Oct. 16, 2019**  
Int. Reg. Pub. Date: **May 15, 2020**

(30) **Foreign Application Priority Data**

Apr. 16, 2019 (KR) ..... 30-2019-0017875

(51) **LOC (13) Cl.** ..... **12-08**

(52) **U.S. Cl.**  
USPC ..... **D12/421**

(58) **Field of Classification Search**

USPC ..... D12/415-426.1  
CPC ..... B60R 2011/0007; B60R 2011/0014; B60R 2011/0021; B60N 3/001; B60N 3/002; B60N 3/007

See application file for complete search history.

(56) **References Cited**

**U.S. PATENT DOCUMENTS**

D535,609 S \* 1/2007 Vitito ..... D12/421  
D535,937 S \* 1/2007 Vitito ..... D12/421

D535,957 S \* 1/2007 Vitito ..... D12/421  
D538,737 S \* 3/2007 Scully ..... D12/421  
D543,930 S \* 6/2007 Vitito ..... D12/421  
D710,786 S \* 8/2014 Tilscher ..... D12/424  
D742,806 S \* 11/2015 Vissers ..... D12/421  
D742,807 S \* 11/2015 Vissers ..... D12/421  
D800,635 S \* 10/2017 Fontaeus ..... D12/416  
D824,324 S \* 7/2018 Gao ..... D12/415  
D877,692 S \* 3/2020 Egbufoama ..... D12/415

\* cited by examiner

*Primary Examiner* — George D. Kirschbaum

*Assistant Examiner* — Joseph J Kukella

(74) *Attorney, Agent, or Firm* — Birch, Stewart, Kolasch & Birch LLP

(57) **CLAIM**

The ornamental design for an automobile, as shown and described.

**DESCRIPTION**

1. Automobile

Fig. 1.1 is a front perspective view of the automobile;

Fig. 1.2 is a front view thereof;

Fig. 1.3 is a back view thereof;

Fig. 1.4 is a left view thereof where the right view is a mirror image;

Fig. 1.5 is a top view thereof;

Fig. 1.6 is an enlarged view of Fig. 1.1;

Fig. 1.7 is an enlarged view of Fig. 1.5;

Fig. 1.8 shows the article in an alternate position;

Fig. 1.9 is an enlarged view of Fig. 1.8; the bottom views are omitted since they cannot be seen in use and form no part of the claimed design.

The dash-dash broken lines depict portions of the automobile that form no part of the claimed design; the dash-dot broken lines define the boundary of the claimed design and form no part thereof.

**1 Claim, 9 Drawing Sheets**

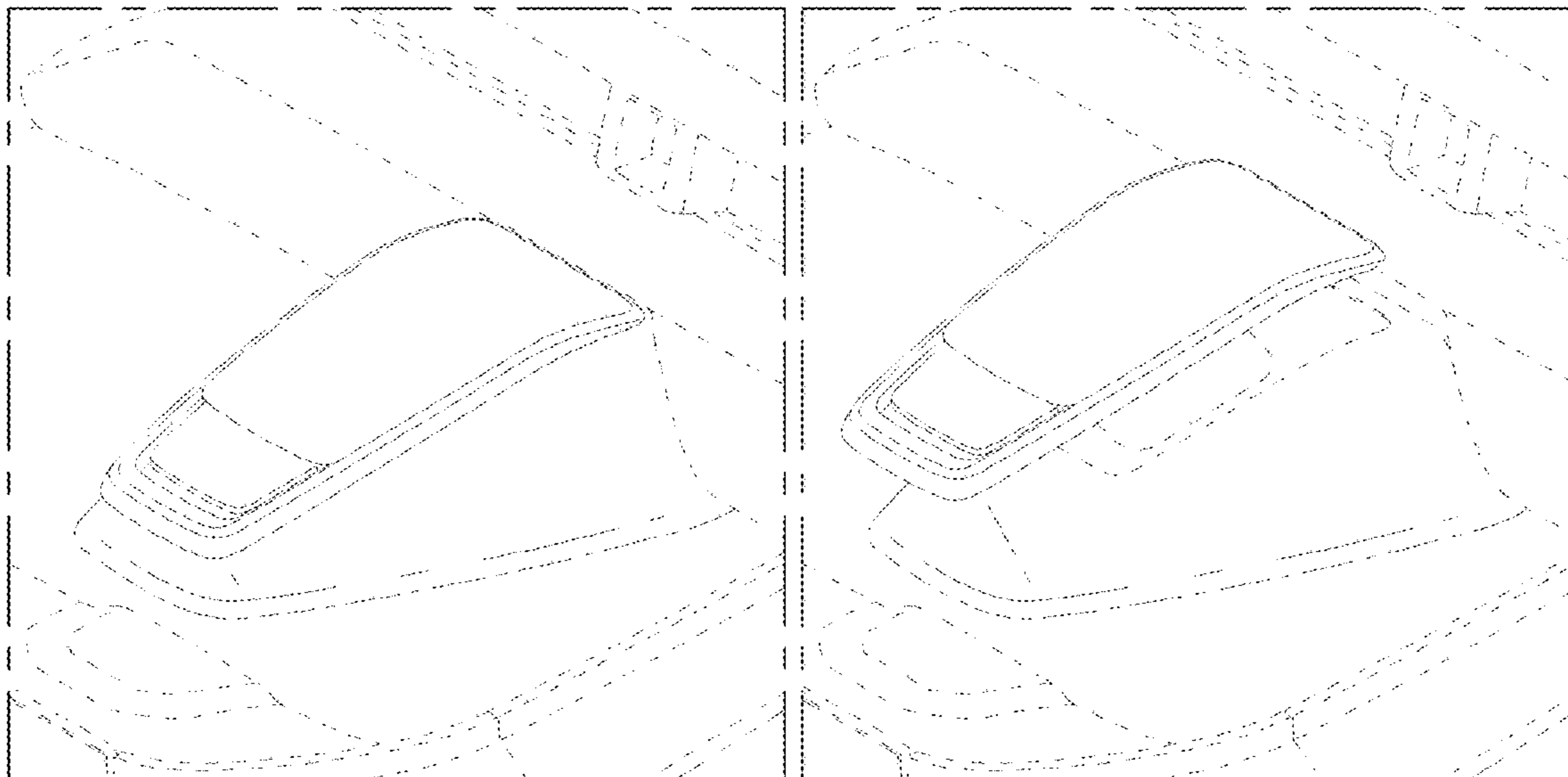

1.1

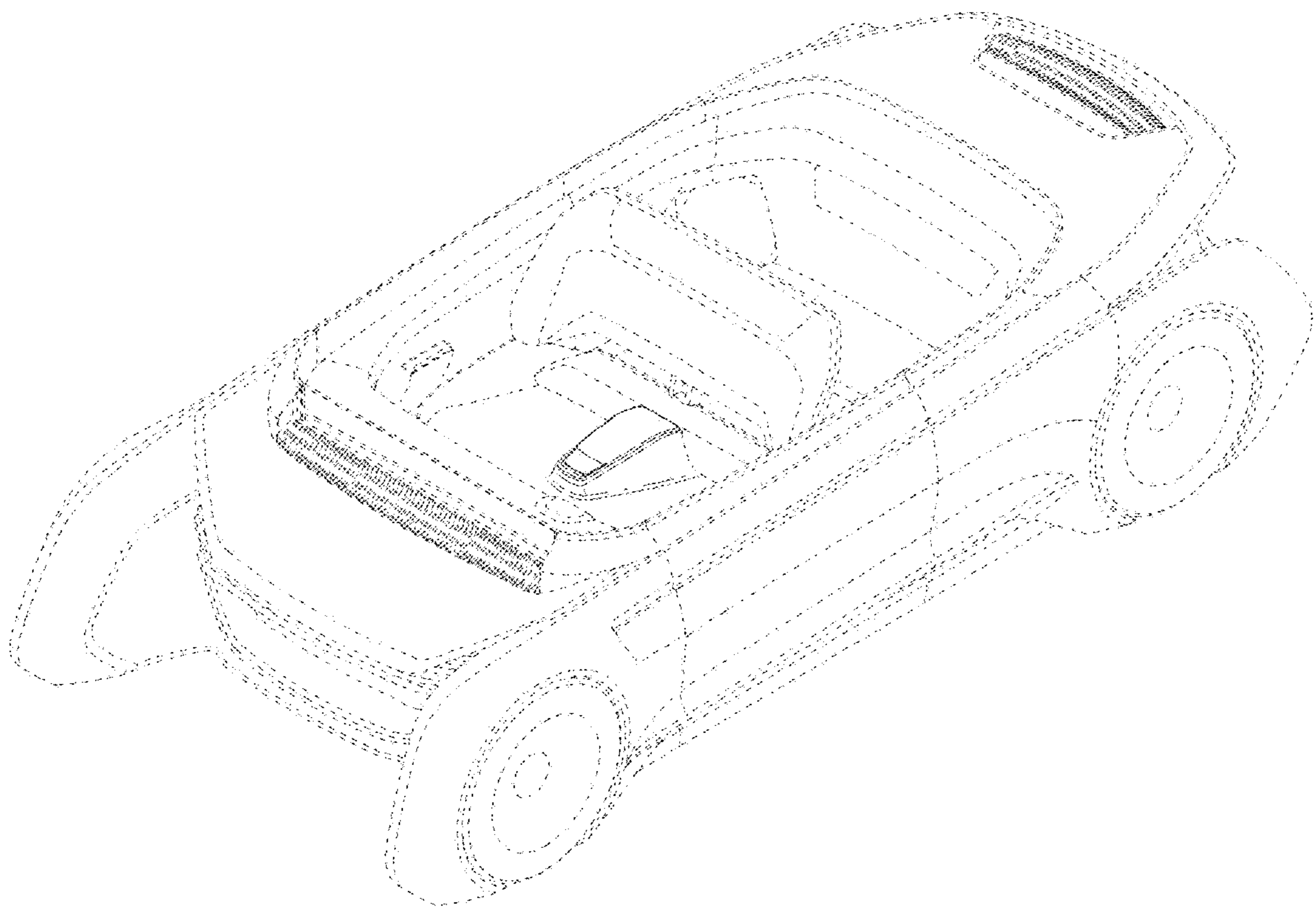

1.2

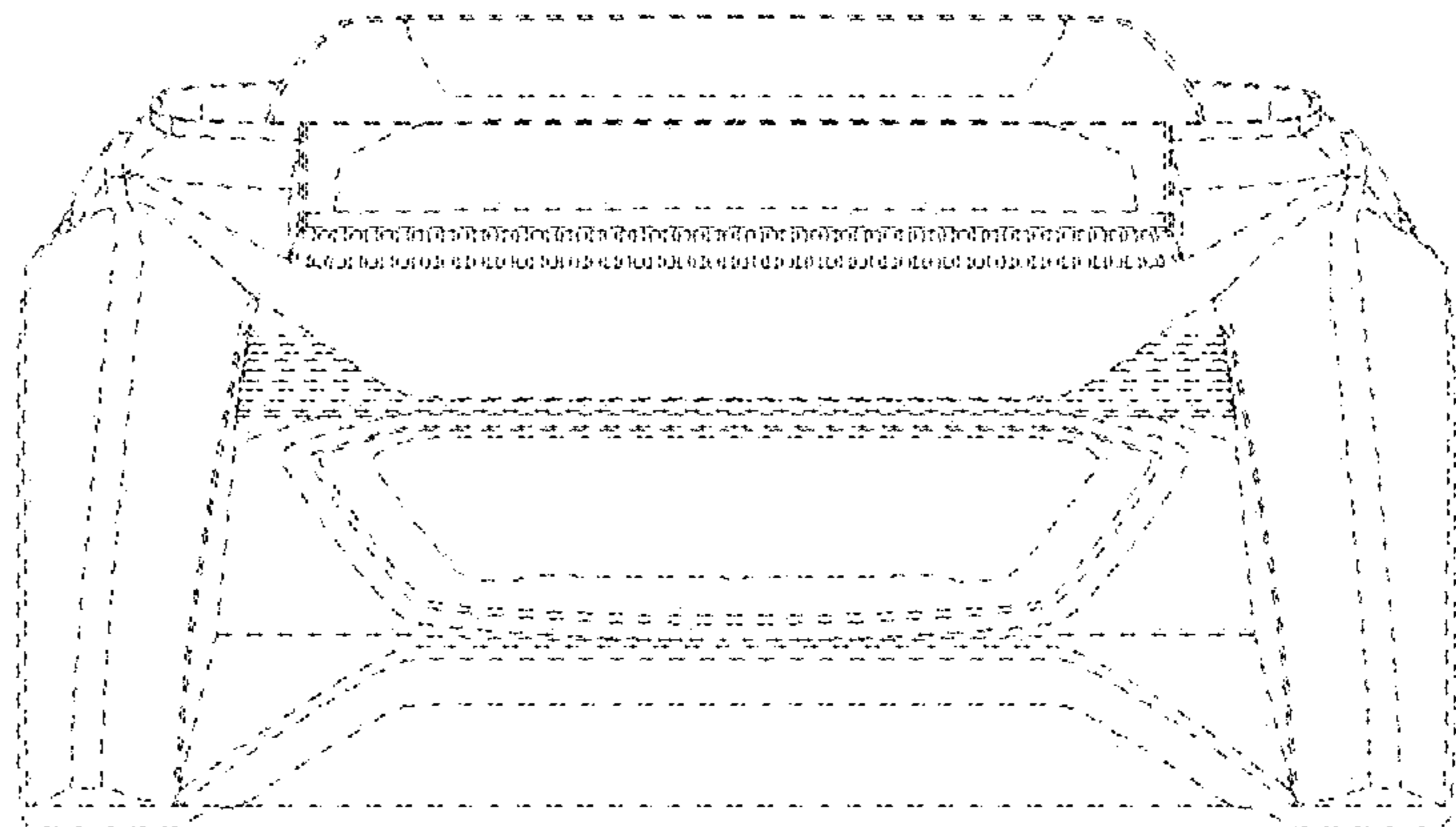

1.3

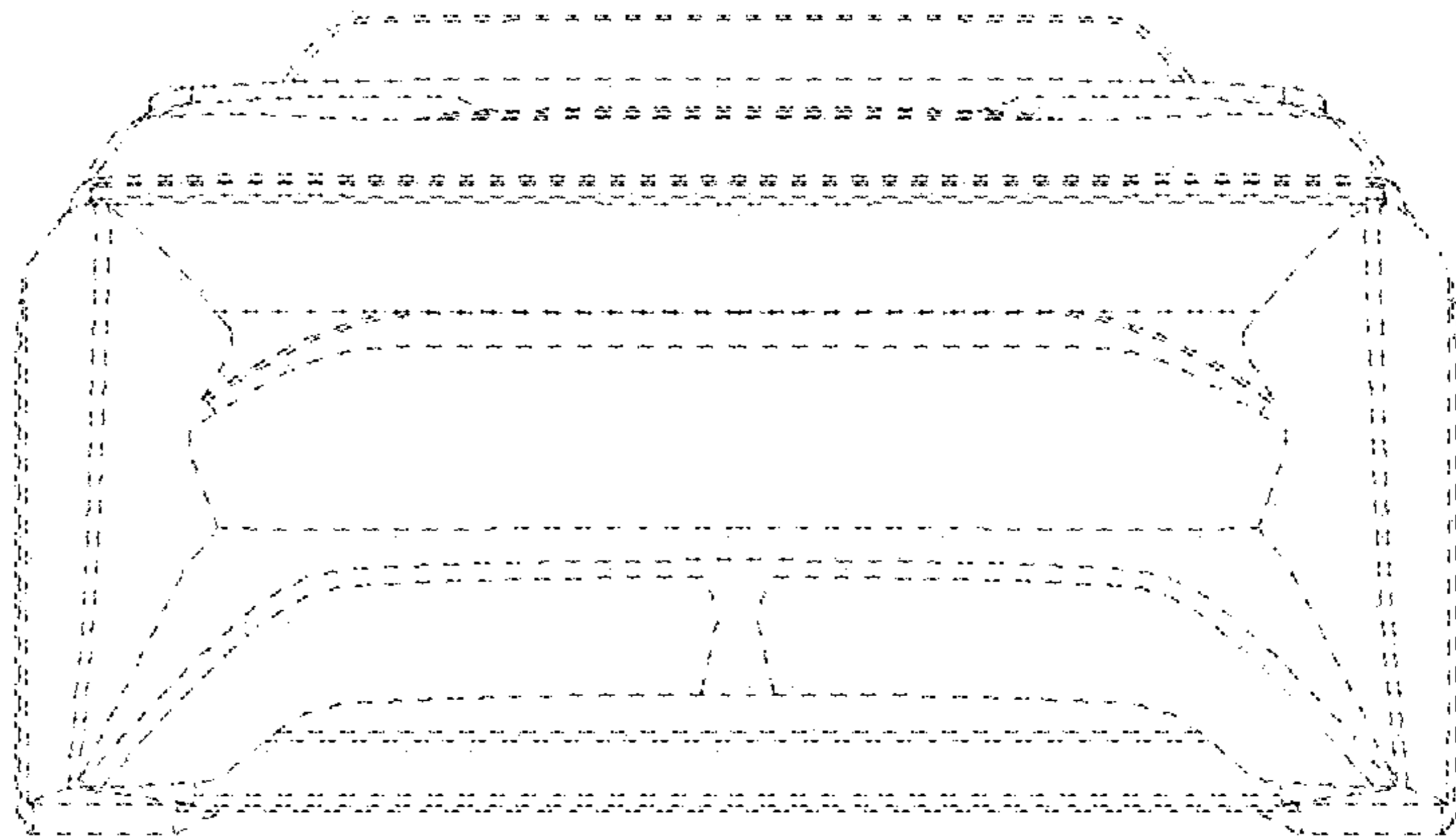

1.4

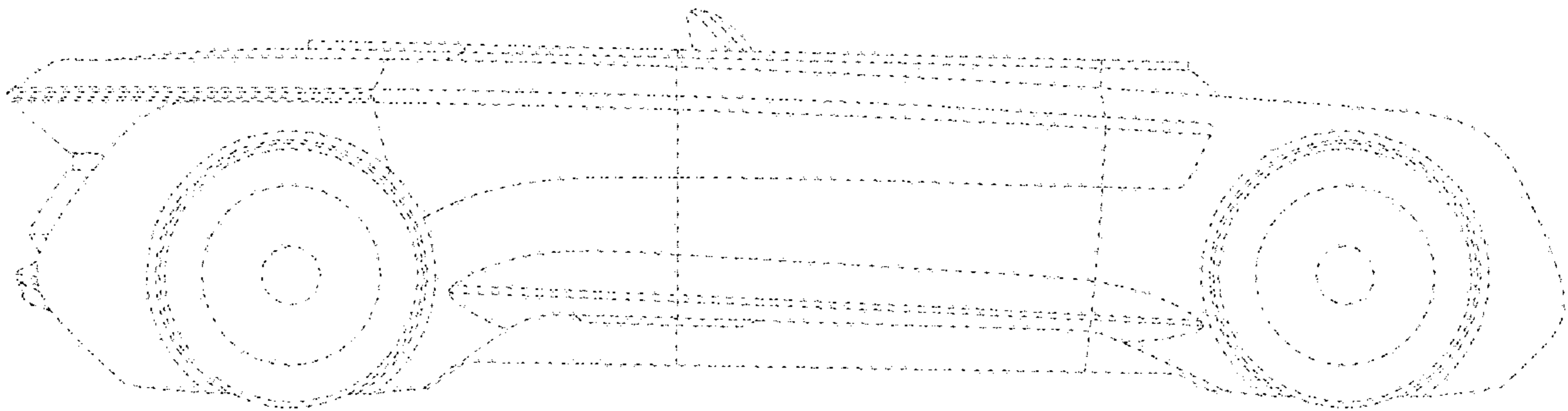

1.5

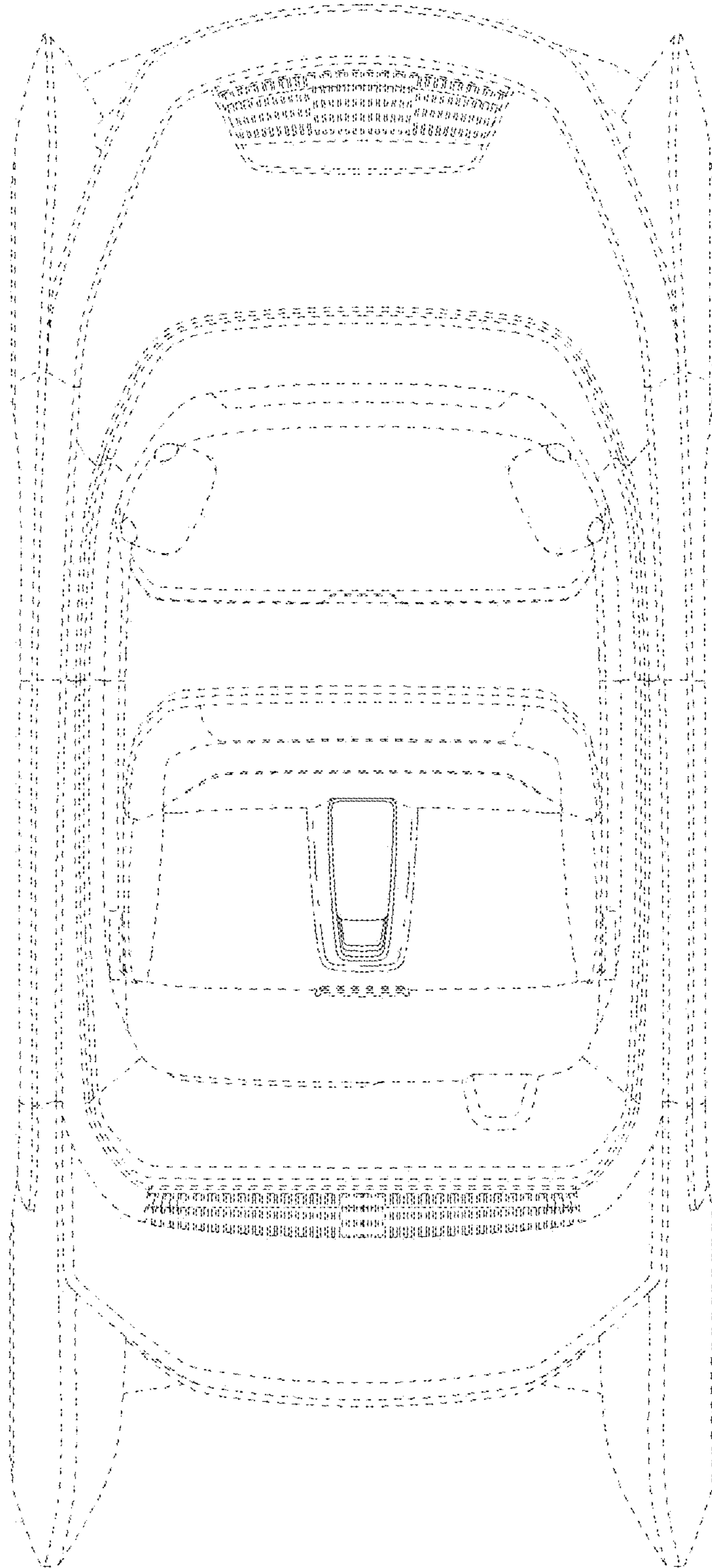

1.6

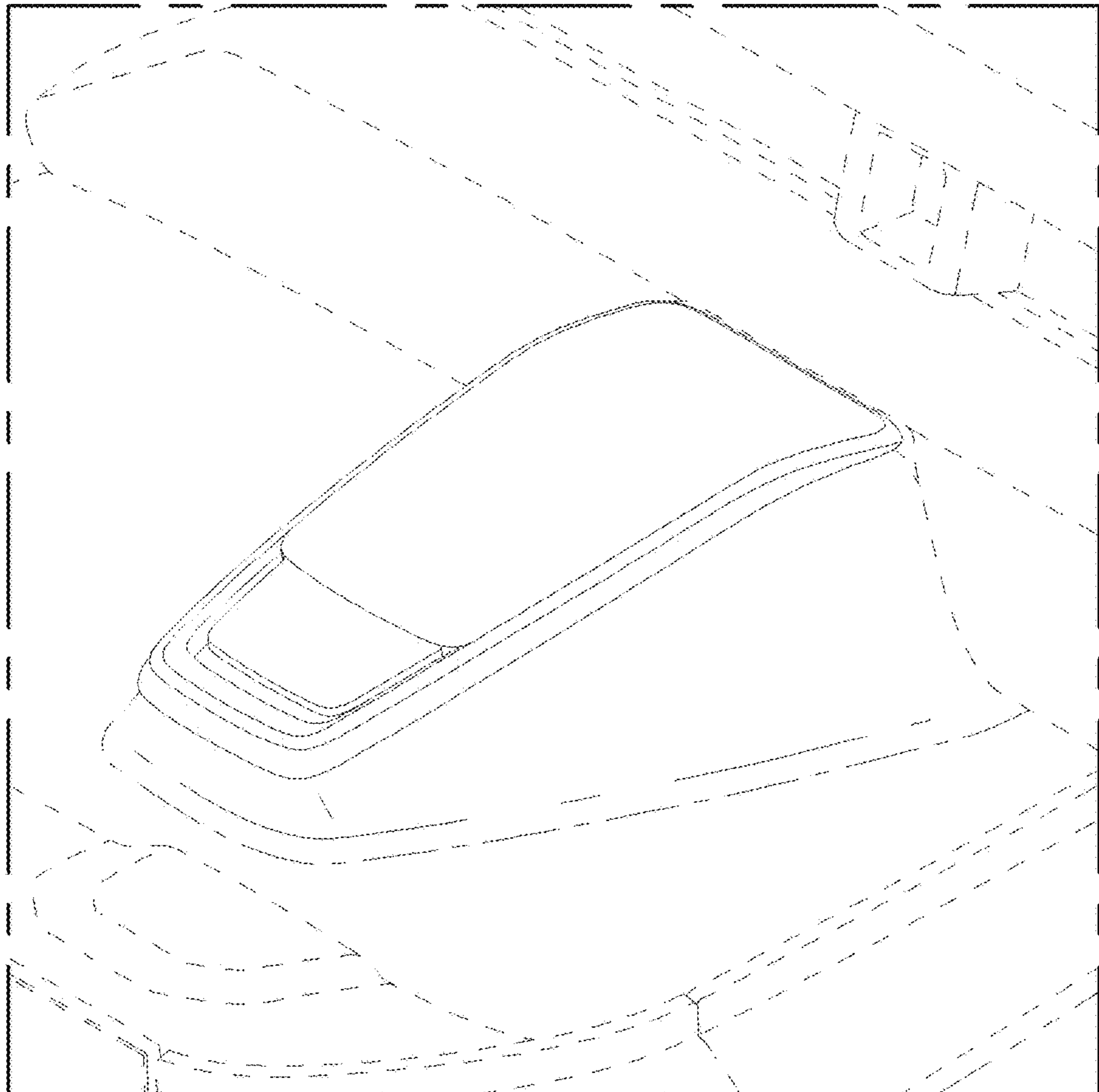

1.7

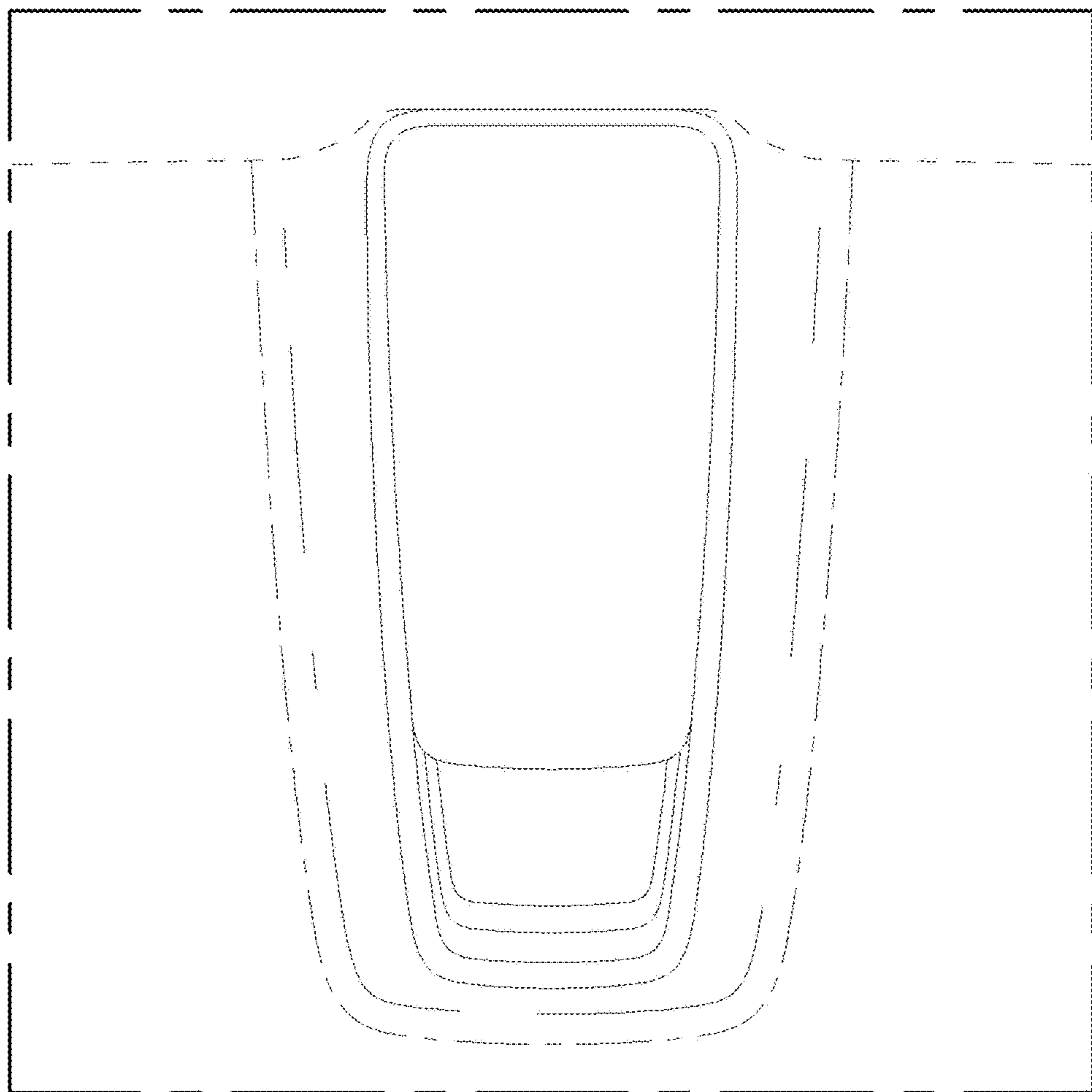



1.8

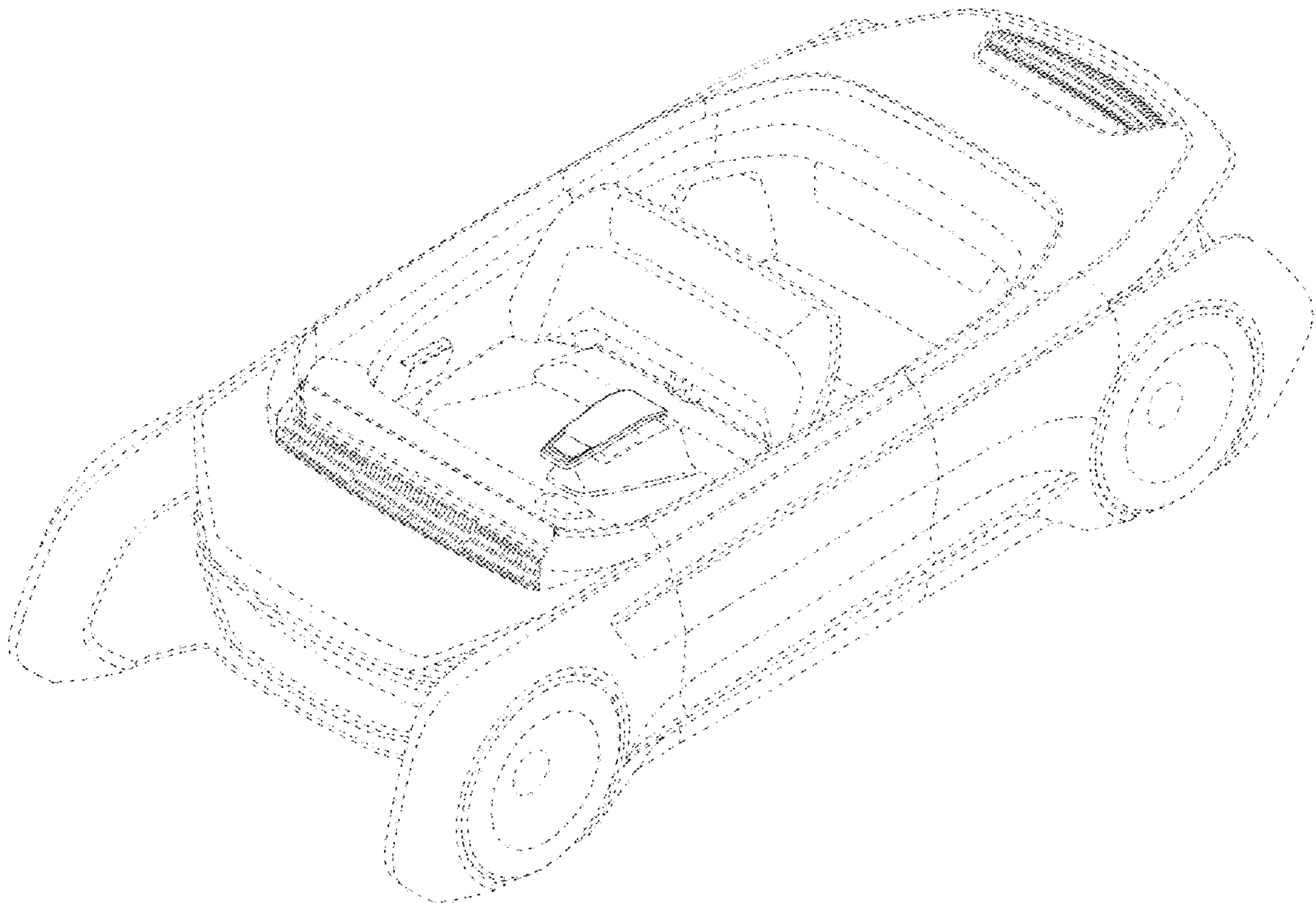

1.9

