



US00D929277S

(12) **United States Design Patent** (10) **Patent No.:** **US D929,277 S**  
**Chan et al.** (45) **Date of Patent:** **\*\* Aug. 31, 2021**

(54) **REAR BUMPER**

(71) Applicant: **Jaguar Land Rover Limited**, Coventry (GB)

(72) Inventors: **Alex Chan**, Coventry (GB); **Paven Patel**, Coventry (GB)

(73) Assignee: **JAGUAR LAND ROVER LIMITED**, Whitley Coventry (GB)

(\*\*) Term: **15 Years**

(21) Appl. No.: **29/704,212**

(22) Filed: **Sep. 3, 2019**

**Related U.S. Application Data**

(62) Division of application No. 29/629,401, filed on Dec. 13, 2017, now Pat. No. Des. 864,055.

(30) **Foreign Application Priority Data**

Jun. 15, 2017 (EM) ..... 004049054

(51) **LOC (13) Cl.** ..... **12-16**

(52) **U.S. Cl.**  
USPC ..... **D12/169**

(58) **Field of Classification Search**  
USPC .... D12/86, 90-92, 163, 164, 169, 171, 196, D12/216

(Continued)

(56) **References Cited**

**U.S. PATENT DOCUMENTS**

D637,535 S \* 5/2011 Yukawa ..... D12/169  
D793,927 S \* 8/2017 Potter ..... D12/169

(Continued)

*Primary Examiner* — Leanne Was-Englehart

(74) *Attorney, Agent, or Firm* — Reising Ethington P.C.

(57) **CLAIM**

The ornamental design for a rear bumper, as shown and described.

**DESCRIPTION**

FIG. 1 is a front right perspective view of a rear bumper. FIG. 2 is a front left perspective view of the rear bumper shown in FIG. 1.

FIG. 3 is a rear left perspective view thereof.

FIG. 4 is a rear right perspective view thereof.

FIG. 5 is a front view thereof.

FIG. 6 is a rear view thereof.

FIG. 7 is a right side view thereof.

FIG. 8 is a left side view thereof.

FIG. 9 is a top view thereof.

FIG. 10 is a bottom view thereof.

FIG. 11 is a front view of the rear bumper shown in FIGS. 1-10, but with the rear bumper mounted on a vehicle, and the rest of the vehicle shown in de-emphasized and half-tone portions so as to illustrate environmental structure. These portions form no part of the claimed design. More particularly, in FIG. 11 the inventive rear bumper is shown within the broken line, and the elements shown outside the broken line form no part of the claimed design, but are instead included to show environmental aspects thereof.

FIG. 12 is a front right perspective view of a rear bumper according to an alternative embodiment.

FIG. 13 is a front left perspective view of the rear bumper shown in FIG. 12.

FIG. 14 is a rear left perspective view thereof.

FIG. 15 is a rear right perspective view thereof.

FIG. 16 is a front view thereof.

FIG. 17 is a rear view thereof.

FIG. 18 is a right side view thereof.

FIG. 19 is a left side view thereof.

FIG. 20 is a top view thereof.

FIG. 21 is a bottom view thereof; and,

FIG. 22 is a front view of the rear bumper shown in FIGS. 12-21, but with the rear bumper mounted on a vehicle, and the rest of the vehicle shown in de-emphasized and half-tone portions so as to illustrate environmental structure. These portions form no part of the claimed design. More particularly, in FIG. 22 the inventive rear bumper is shown within

(Continued)

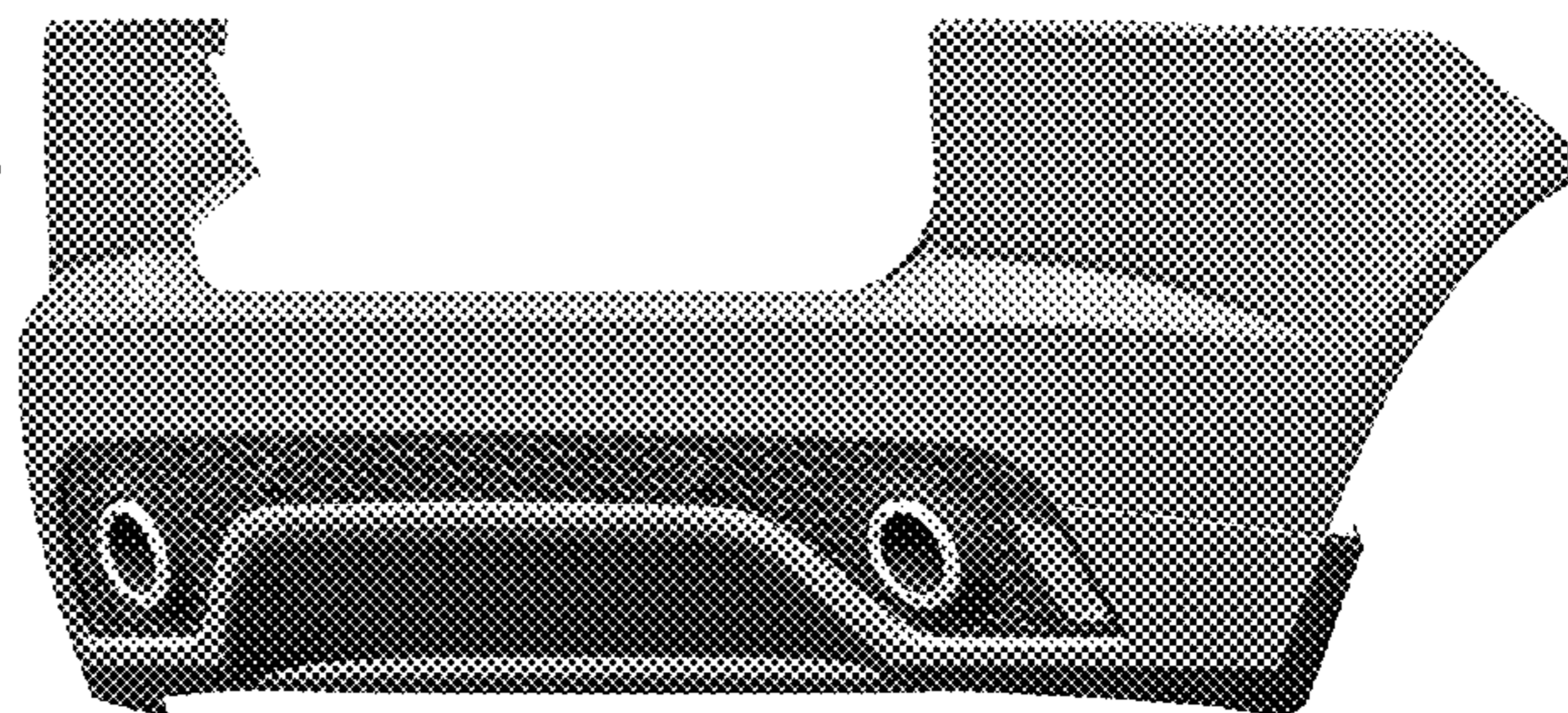
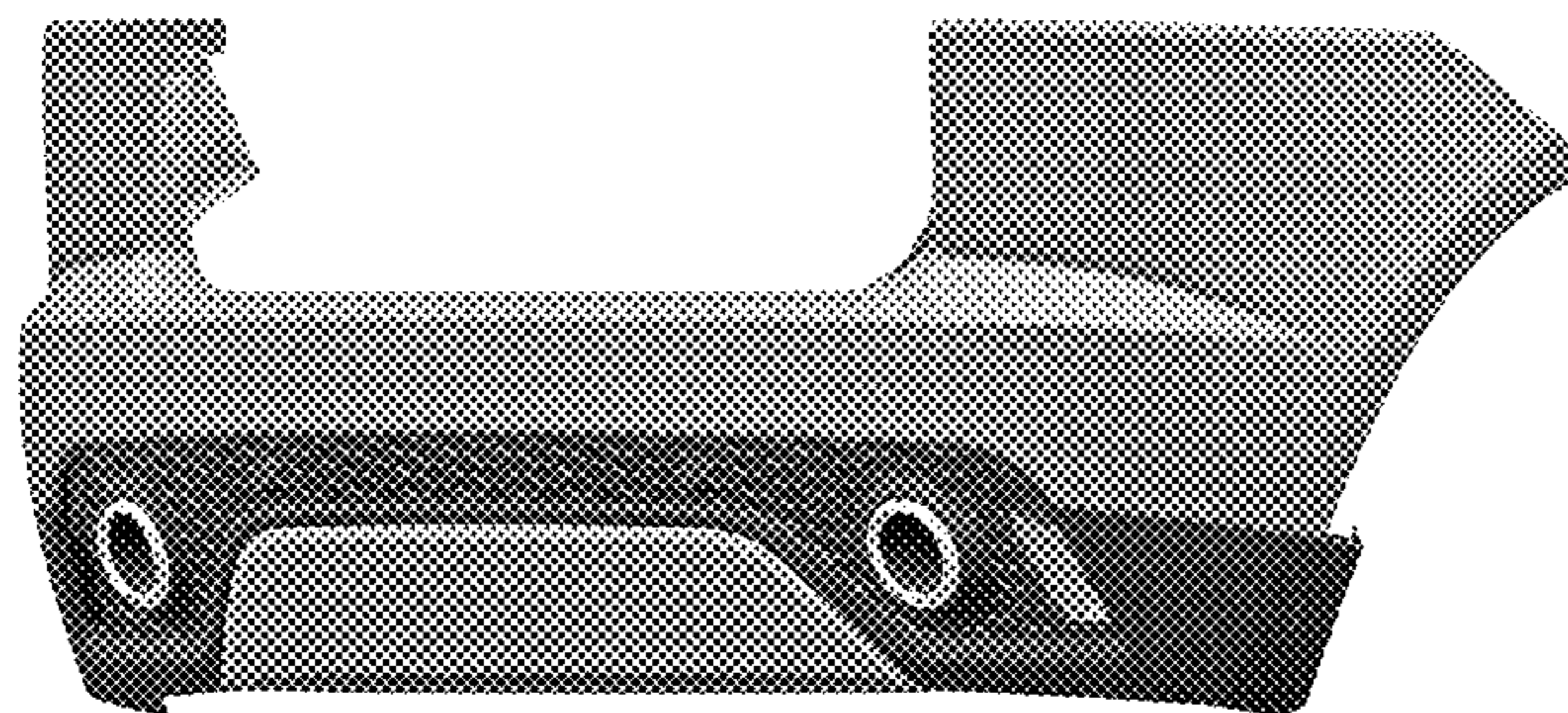

the broken line, and the elements shown outside the broken line form no part of the claimed design, but are instead included to show environmental aspects thereof.

**1 Claim, 22 Drawing Sheets**

(58) **Field of Classification Search**

CPC ..... B60R 19/02; B60R 19/04; B62D 25/08  
See application file for complete search history.

(56) **References Cited**

U.S. PATENT DOCUMENTS

D797,615 S *	9/2017	Hatton .....	D12/169
D801,885 S *	11/2017	Melikian .....	D12/169
D808,871 S *	1/2018	Peat .....	D12/169
D814,985 S *	4/2018	Peat .....	D12/169
D818,402 S *	5/2018	Kawakami .....	D12/169
D820,175 S *	6/2018	Ishigaki .....	D12/169
D824,816 S *	8/2018	Nakajima .....	D12/169
D824,818 S *	8/2018	Morikawa .....	D12/169
D825,409 S *	8/2018	Kayakabe .....	D12/169
D825,413 S *	8/2018	Luk .....	D12/169
D825,415 S *	8/2018	De Bono .....	D12/169
D827,517 S *	9/2018	Whang .....	D12/169
D831,547 S *	10/2018	Granlund .....	D12/163
D864,055 S *	10/2019	Chan .....	D12/169

\* cited by examiner



FIG. 1



FIG. 2



FIG. 3



FIG. 4

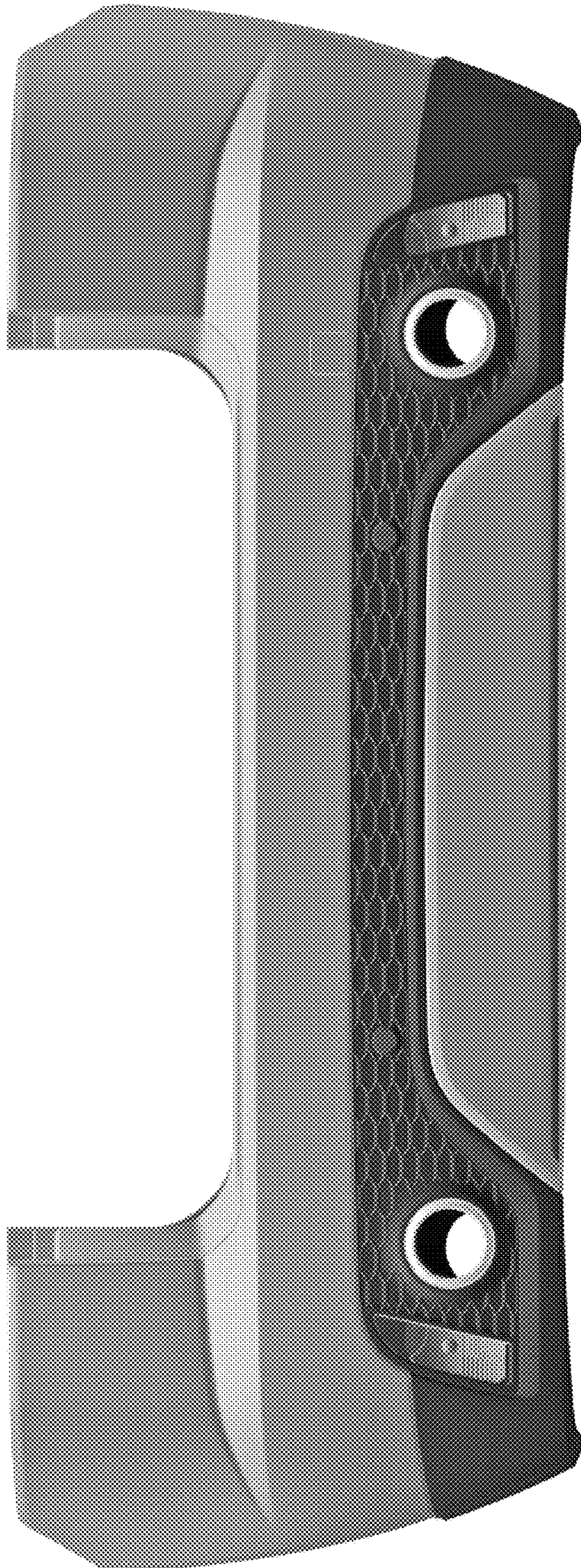

FIG. 5

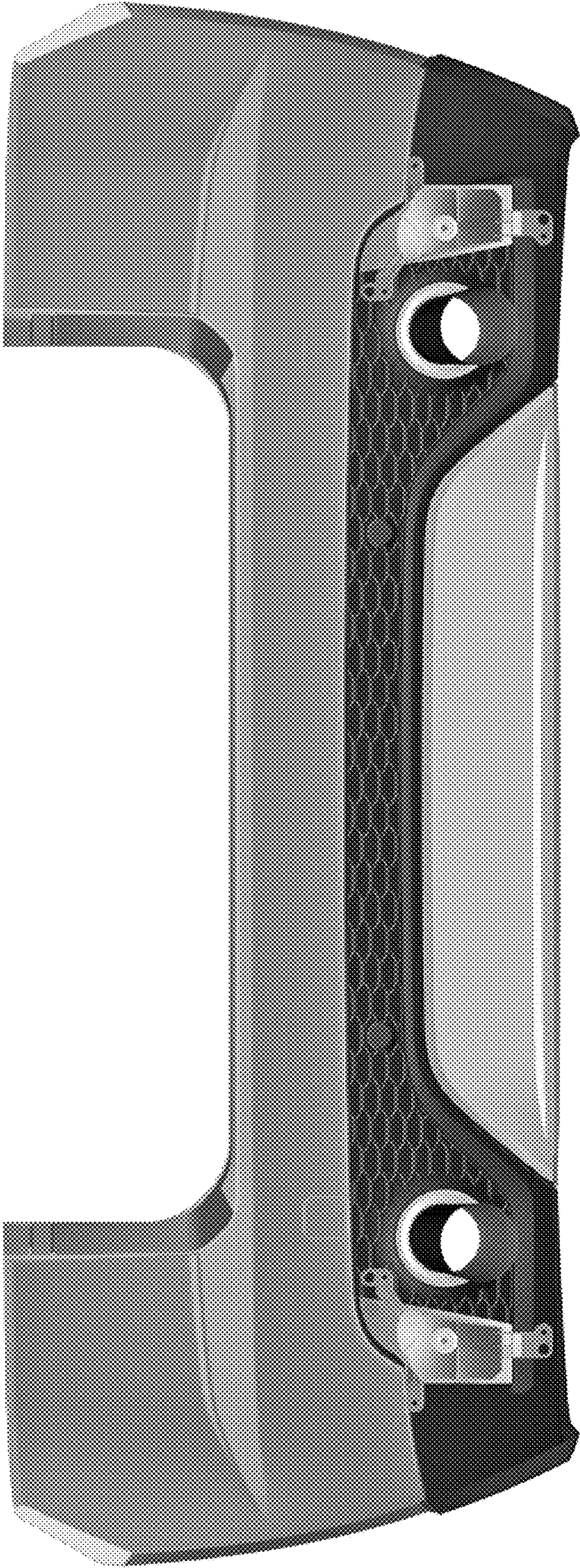

FIG. 6



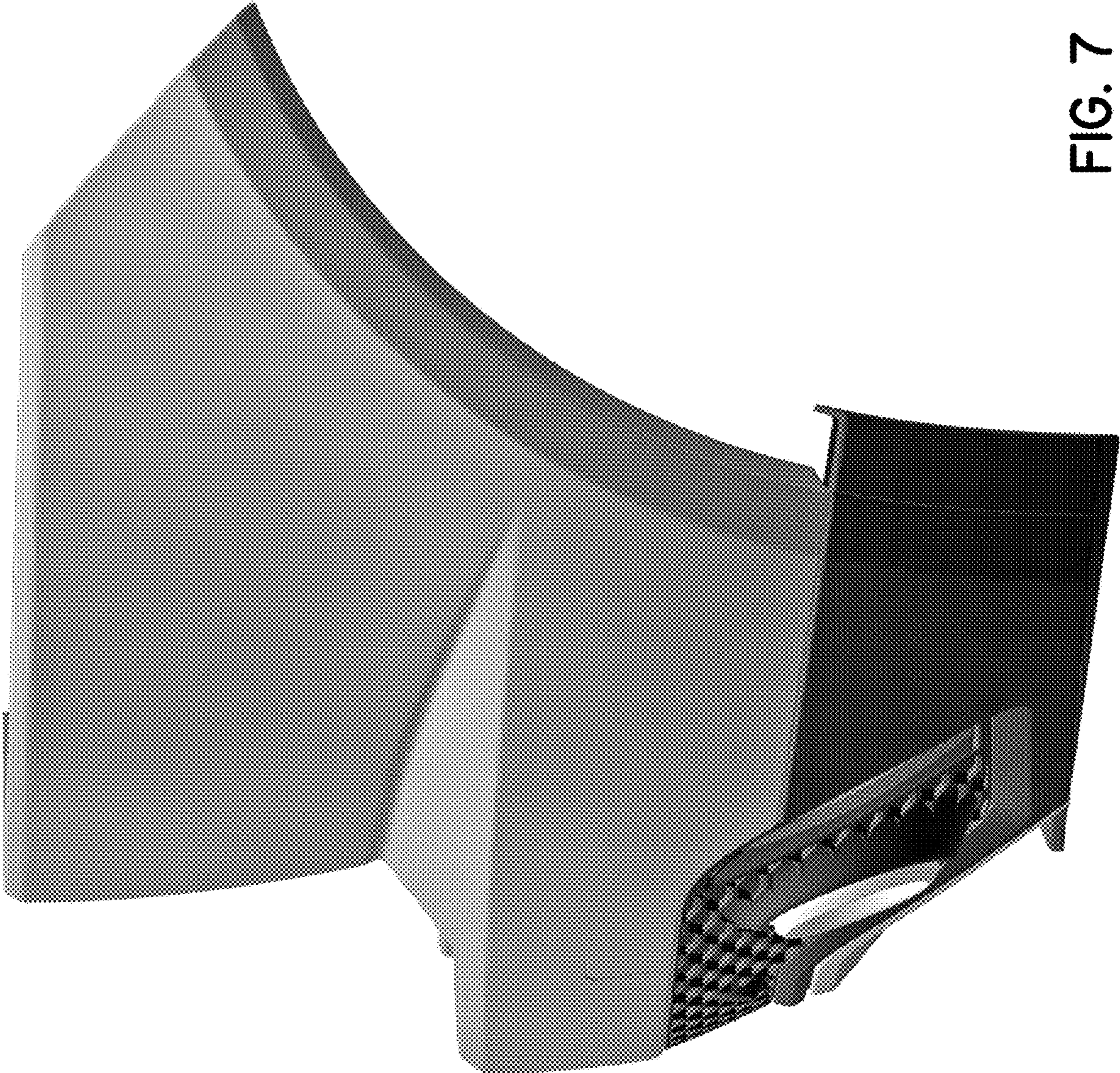

FIG. 7

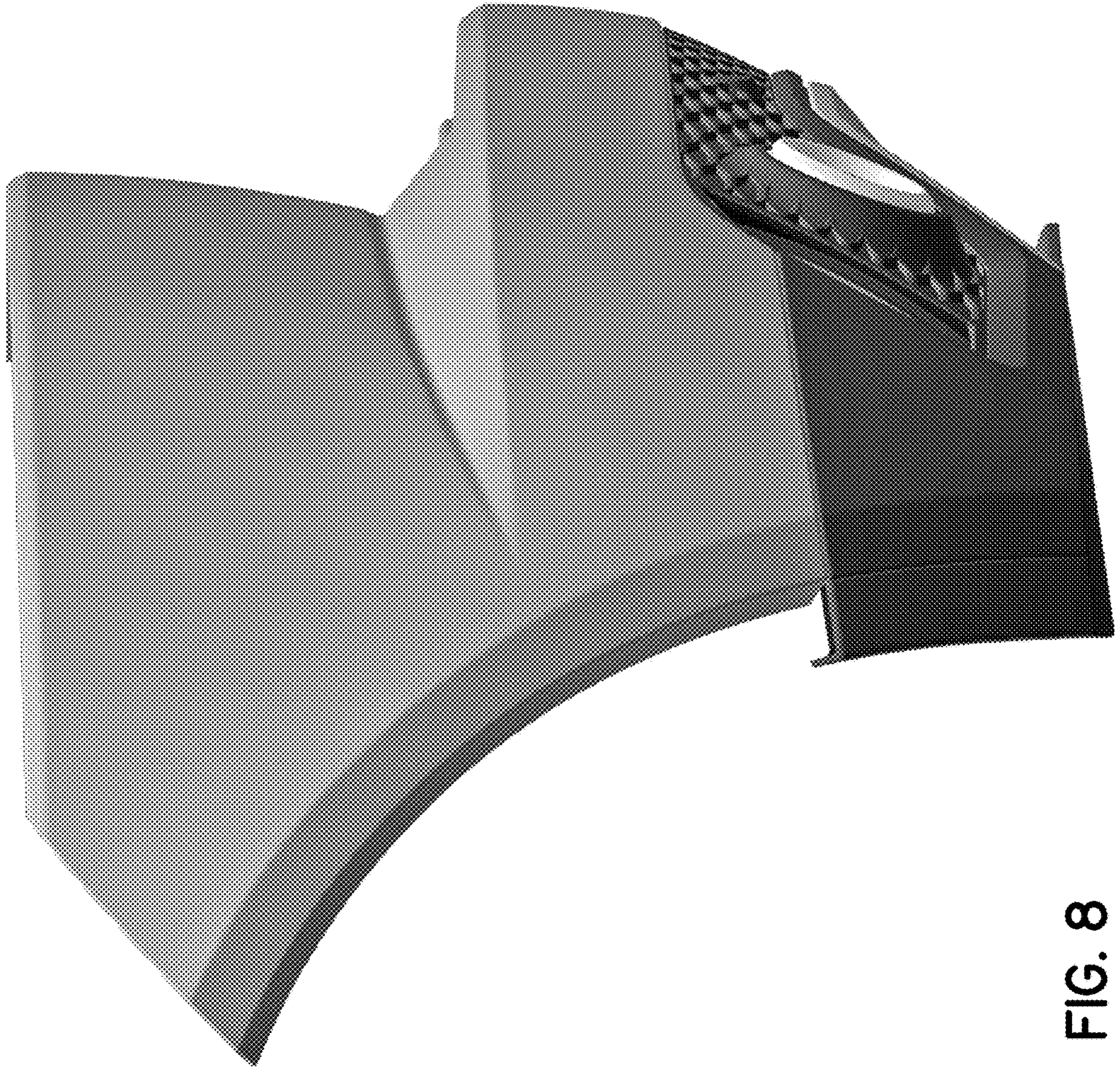

FIG. 8

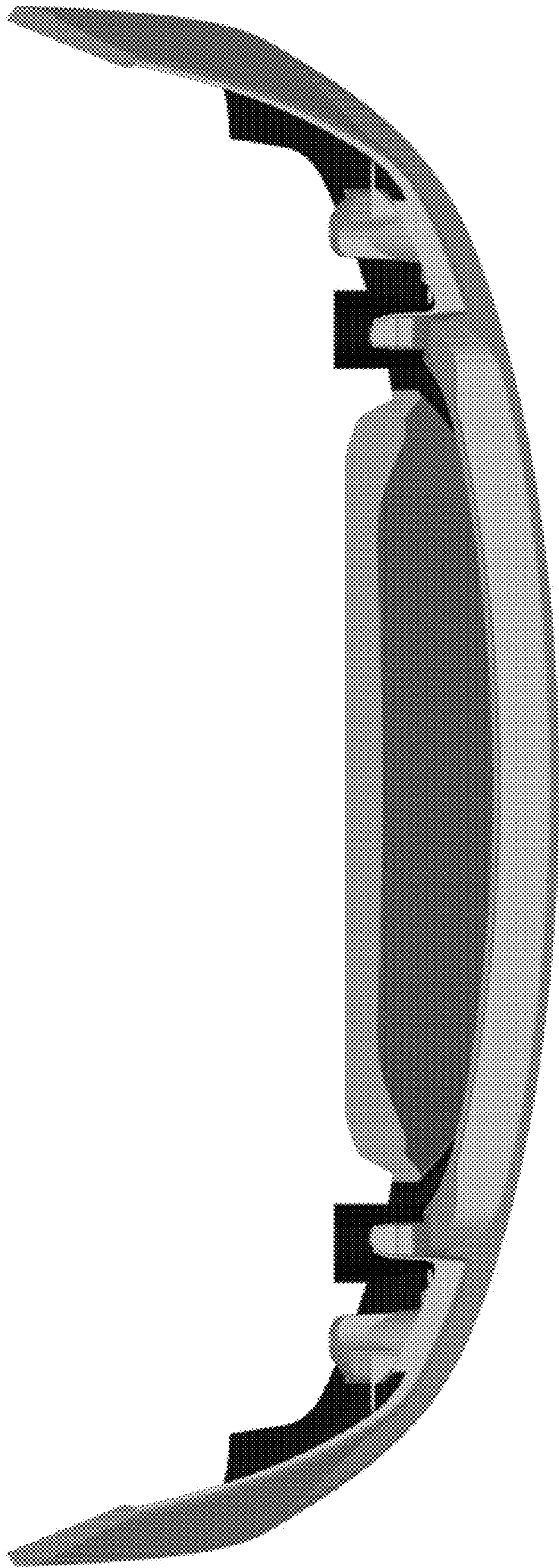

FIG. 9

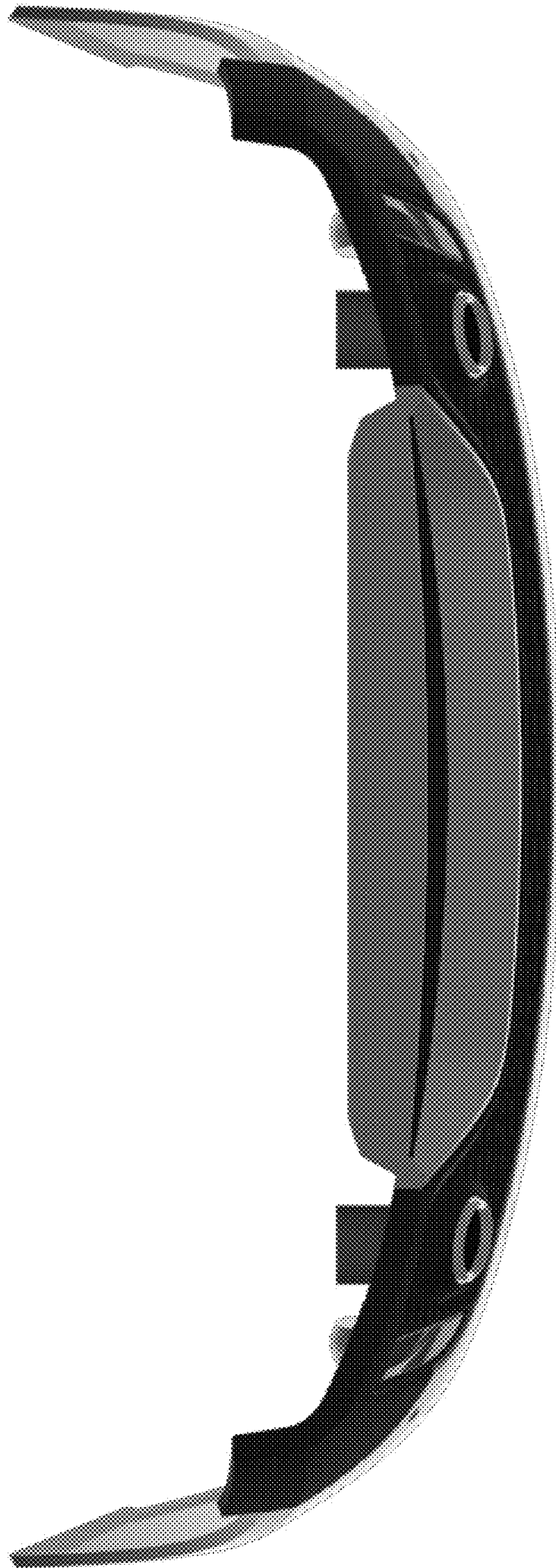

FIG. 10

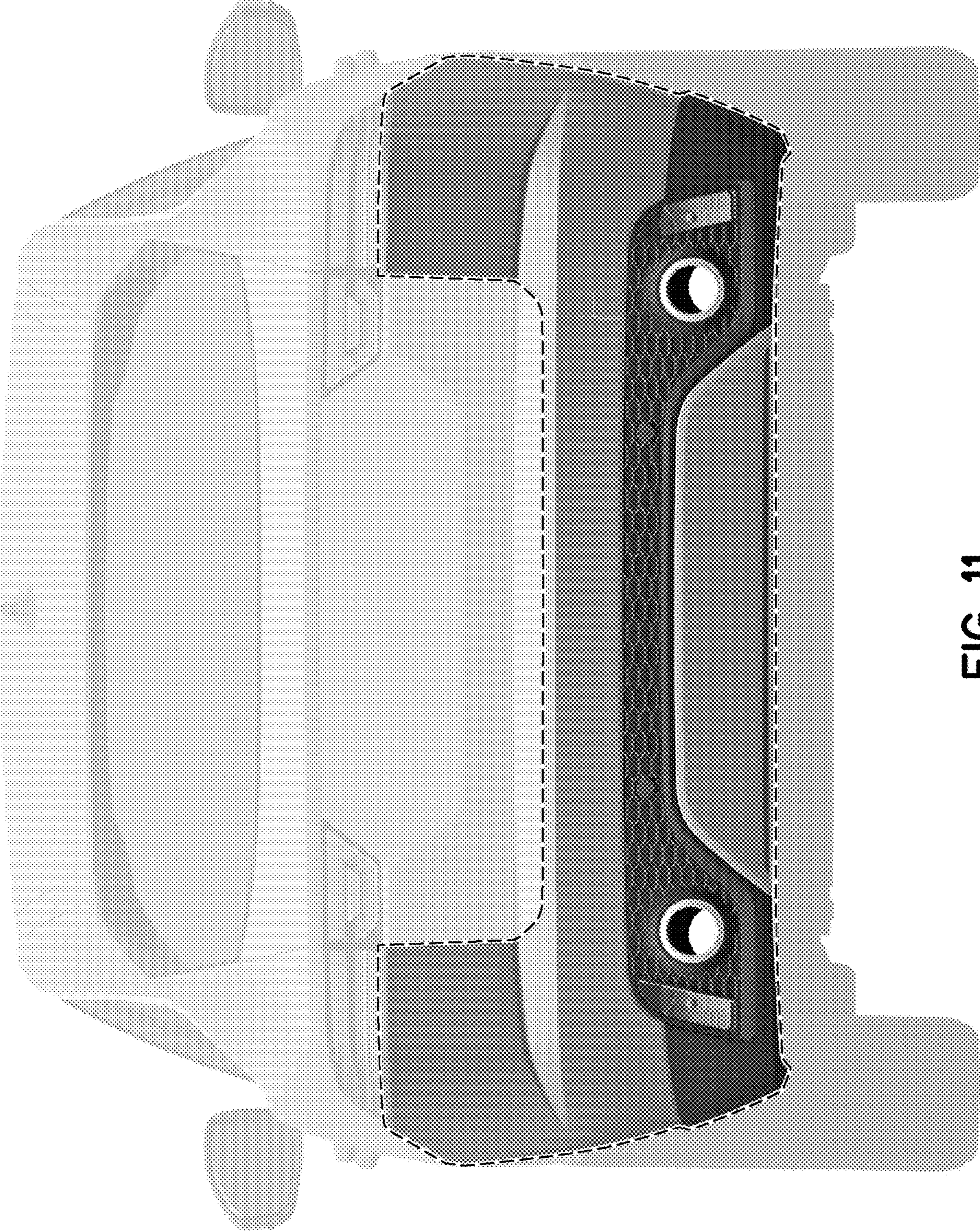

FIG. 11



FIG. 12



FIG. 13



FIG. 14





FIG. 15

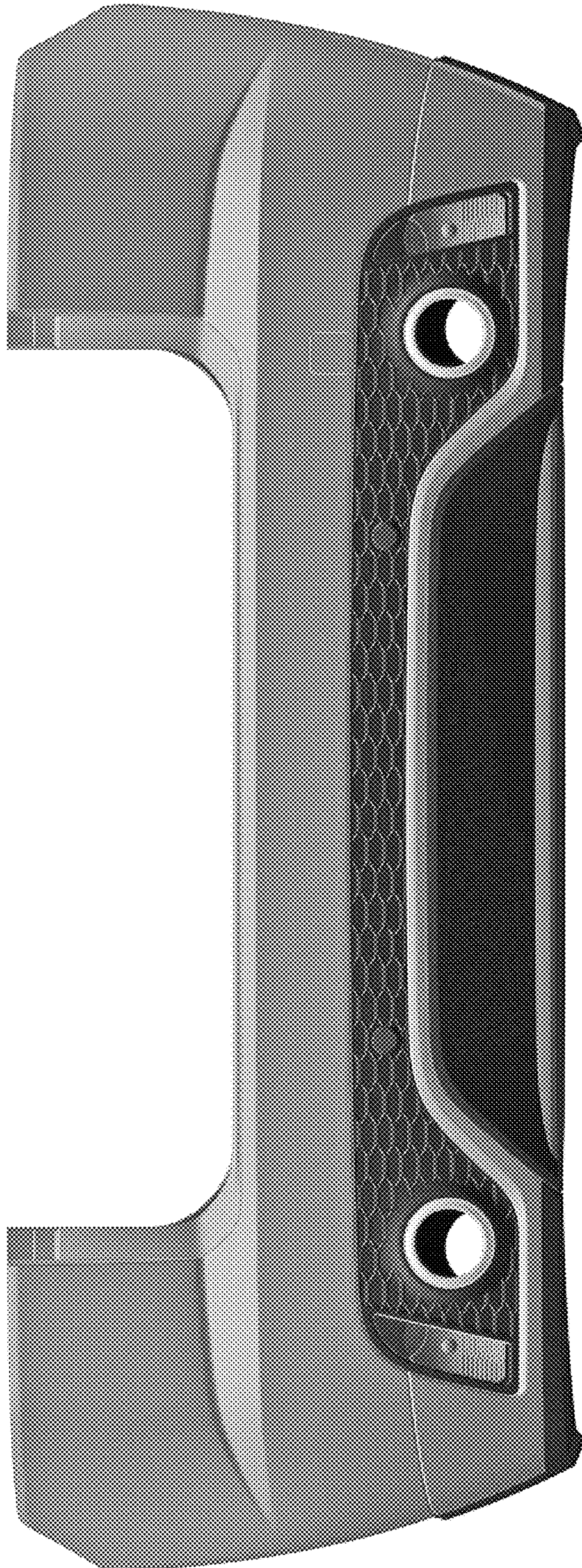

FIG. 16

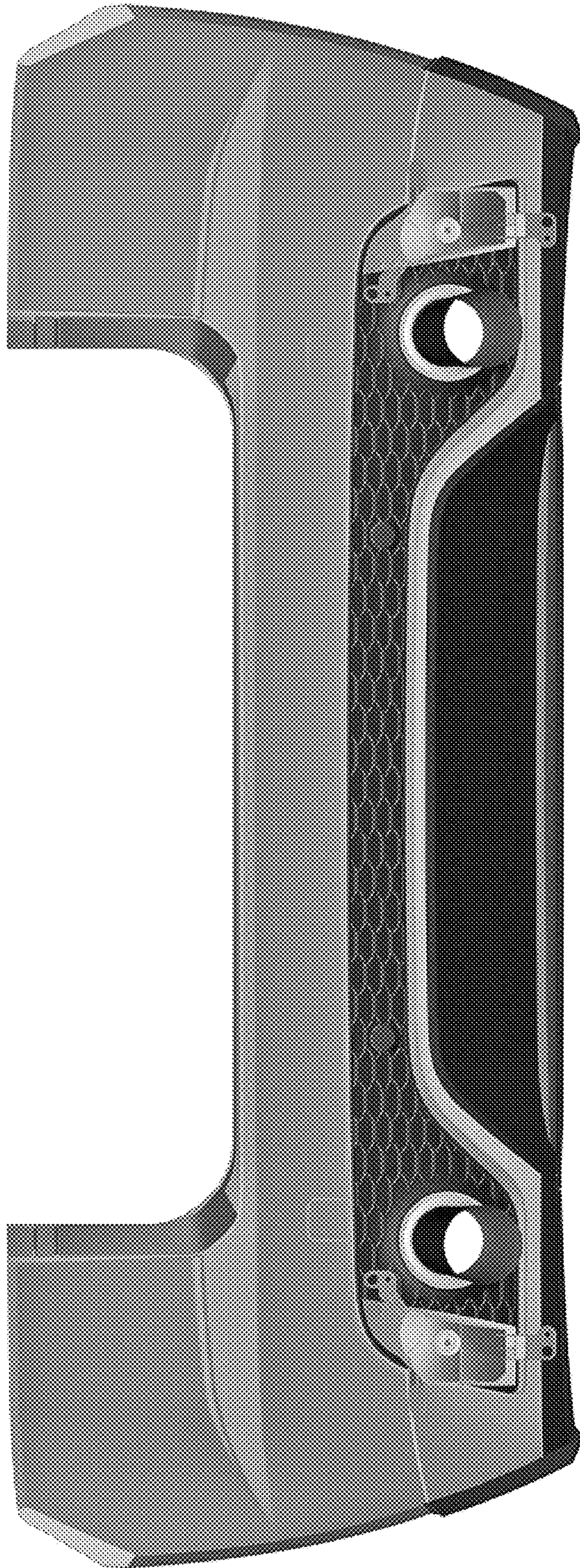

FIG. 17

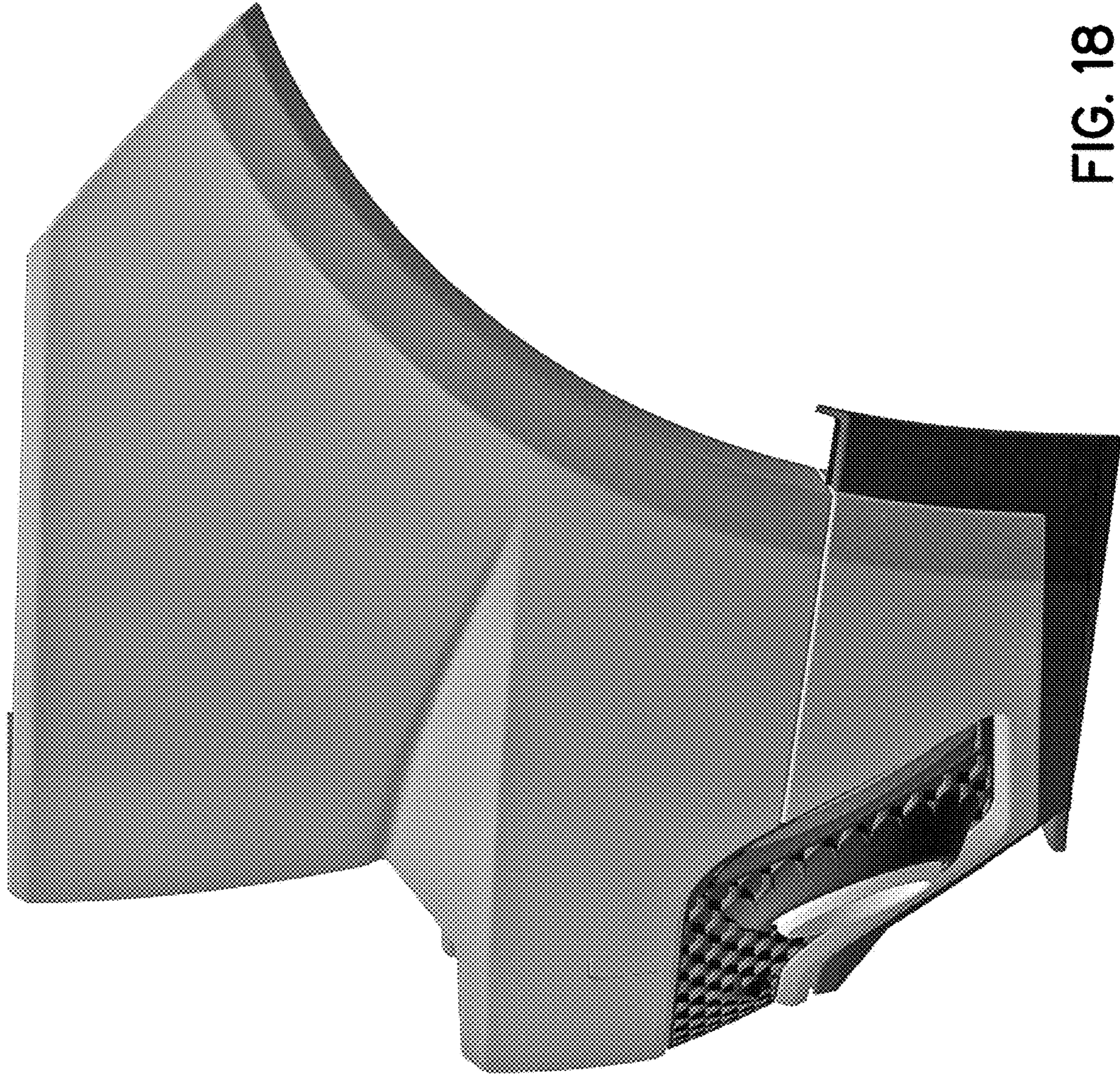

FIG. 18

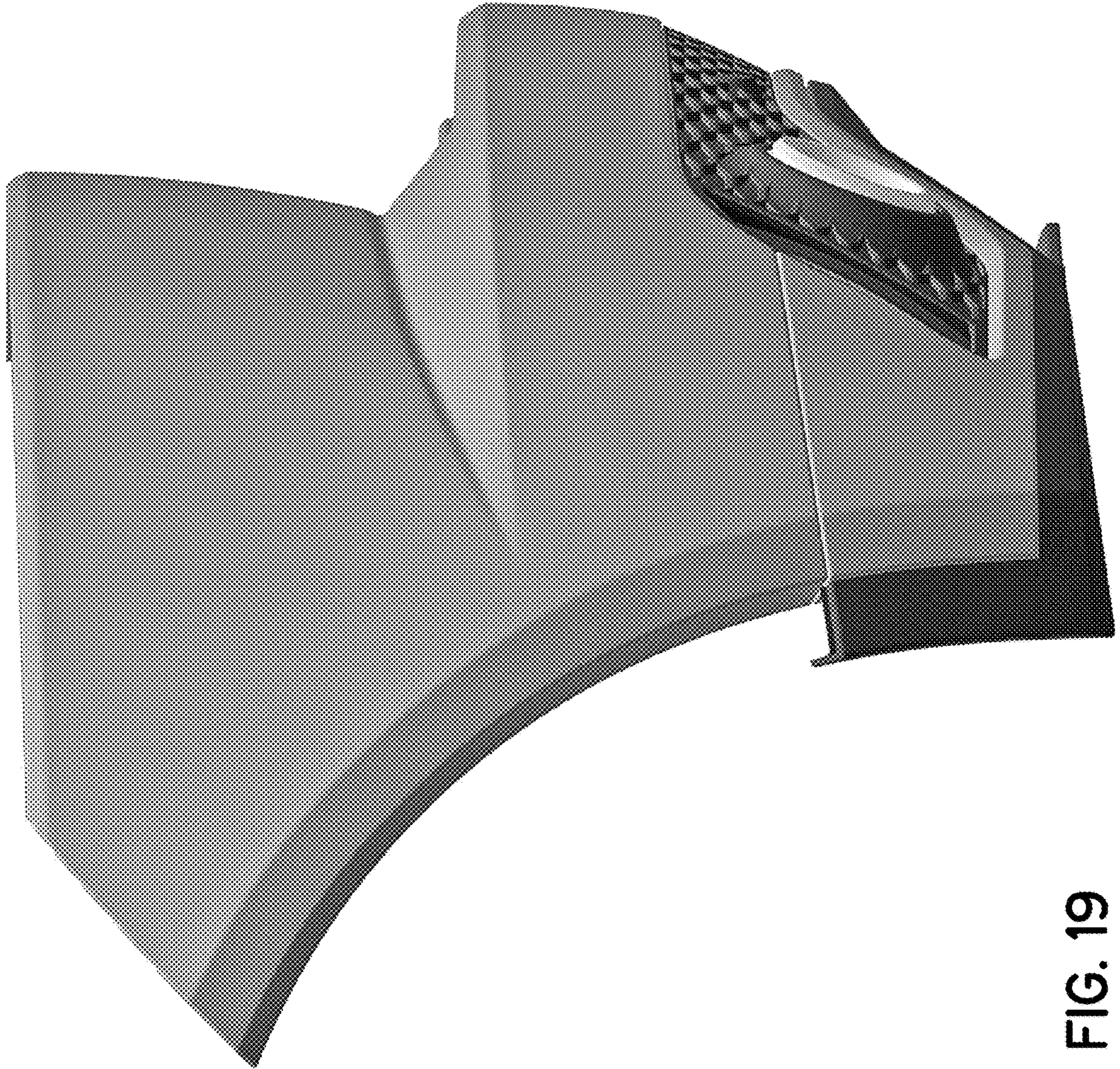

FIG. 19

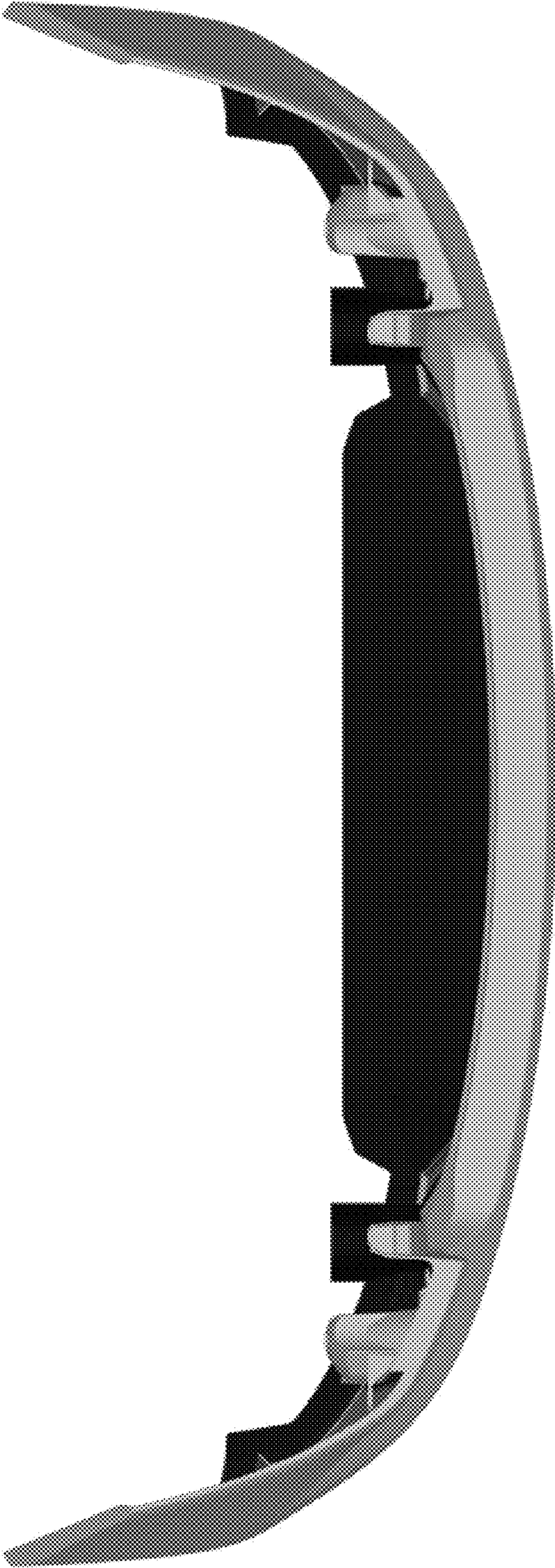

FIG. 20



FIG. 21

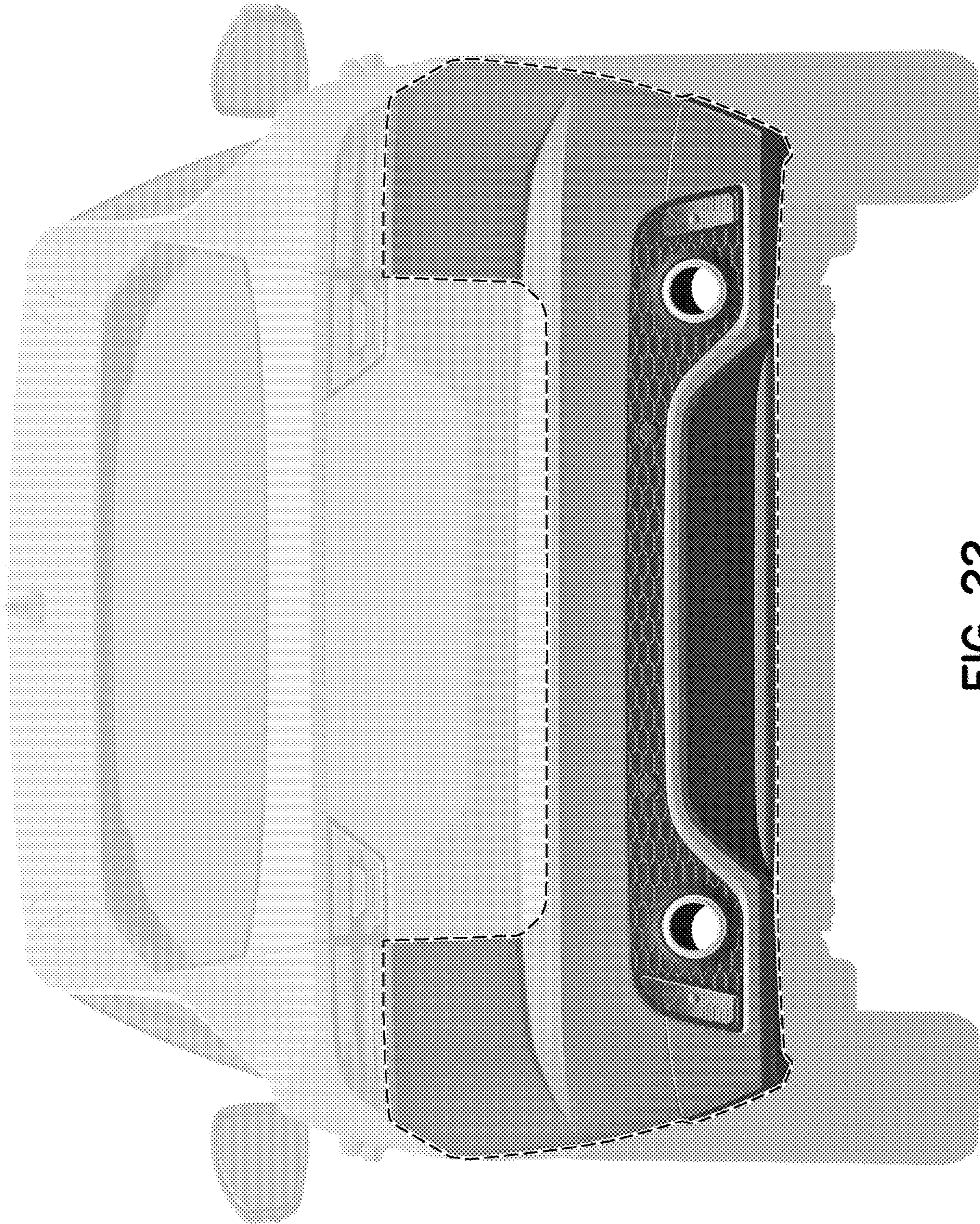

FIG. 22