



US00D929002S

(12) **United States Design Patent** (10) **Patent No.:** **US D929,002 S**
Thomas (45) **Date of Patent:** **** Aug. 24, 2021**

(54) **DAYTIME RUNNING LIGHT ARRANGEMENT**

Primary Examiner — Marcus A Jackson
(74) *Attorney, Agent, or Firm* — Reising Ethington P.C.

(71) Applicant: **JAGUAR LAND ROVER LIMITED**,
Coventry (GB)

(72) Inventor: **Gareth Thomas**, Coventry (GB)

(73) Assignee: **JAGUAR LAND ROVER LIMITED**,
Coventry (GB)

(**) Term: **15 Years**

(21) Appl. No.: **29/771,854**

(22) Filed: **Feb. 25, 2021**

Related U.S. Application Data

(62) Division of application No. 29/674,028, filed on Dec. 19, 2018, now Pat. No. Des. 913,543.

(30) **Foreign Application Priority Data**

Jun. 28, 2018 (EM) 005329109

(51) **LOC (13) Cl.** **26-06**

(52) **U.S. Cl.**
USPC **D26/28**

(58) **Field of Classification Search**

USPC D26/28-36, 139
CPC F21S 48/00; F21S 48/10; F21S 48/115;
F21S 48/225; F21S 48/1233; F21S
48/1266; F21S 48/1388; F21S 48/2268;
F21V 5/00; F21V 21/04; F21V 29/004;
B60Q 9/13; B60Q 9/135; B60Q 9/1375

See application file for complete search history.

(56) **References Cited**

U.S. PATENT DOCUMENTS

D785,829 S * 5/2017 Park D26/28
D797,965 S * 9/2017 Matsumoto D26/28
D819,851 S * 6/2018 Munakata D26/28
D833,658 S * 11/2018 Lee D26/28

(Continued)

(57) **CLAIM**

The ornamental design for a daytime running light arrangement, as shown and described.

DESCRIPTION

FIG. 1 is a front left elevated perspective view of a daytime running light arrangement for a vehicle, shown in dash profile for enhanced clarity;

FIG. 2 is a front left perspective view thereof;

FIG. 3 is a front view thereof;

FIG. 4 is a left side view thereof;

FIG. 5 is a top view thereof;

In FIGS. 1-5, for visual clarity, a darker shade is used to show the activated, or illuminated, state of the various portions of the headlight, in inverted fashion, with those darker shades also bounded by broken lines which form no part of the claimed design. The darker shade itself forms no part of the claimed design. Also, the lighter tones which surround the broken lines are included for environmental purposes and form no part of the claimed design.

FIG. 6 is another front view thereof, but mounted on a vehicle to show environmental structure, the vehicle being unclaimed and shown in broken lines; and,

FIG. 7 shows a variation thereof, with the same daytime running light arrangement shown on the left side, as shown in FIG. 6, plus a mirror image daytime running light arrangement shown also on the right side of the same unclaimed vehicle, with the unclaimed vehicle shown in broken lines.

In both of FIGS. 6 and 7, as in FIGS. 1-5, for clarity the claimed design is shown in darker tones, in inverted fashion. The darker tones, by themselves, form no part of the claimed design.

1 Claim, 7 Drawing Sheets



(56)

References Cited

U.S. PATENT DOCUMENTS

D835,313 S * 12/2018 Jung D26/28
D855,848 S * 8/2019 Lai D26/28

* cited by examiner



FIG. 1

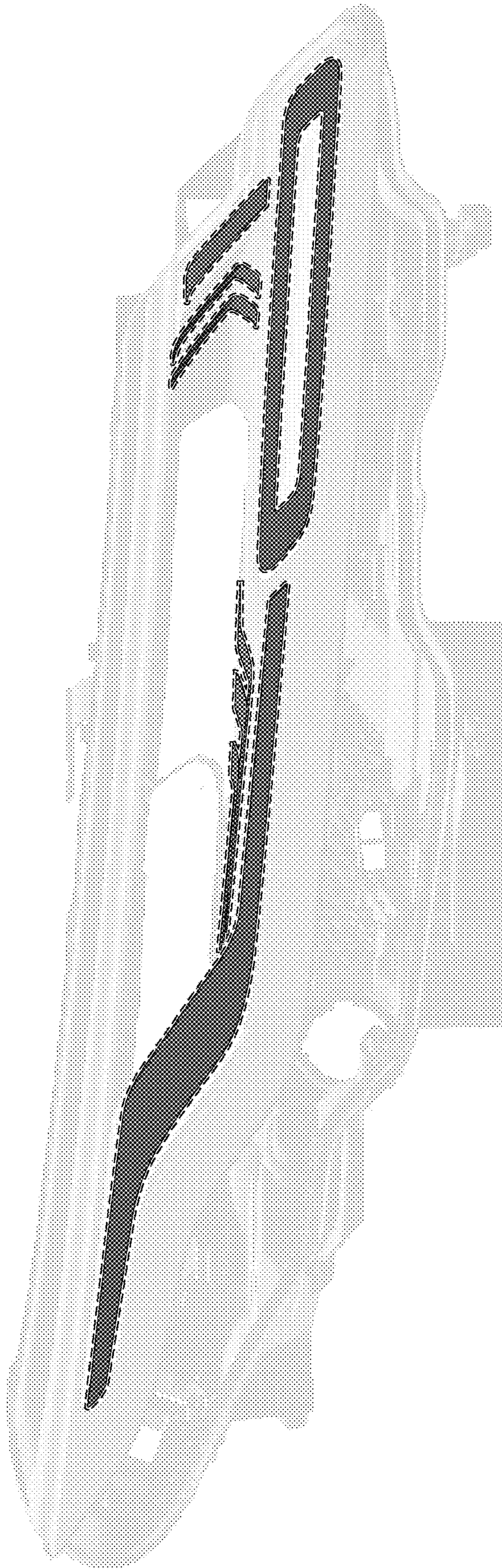

FIG. 2

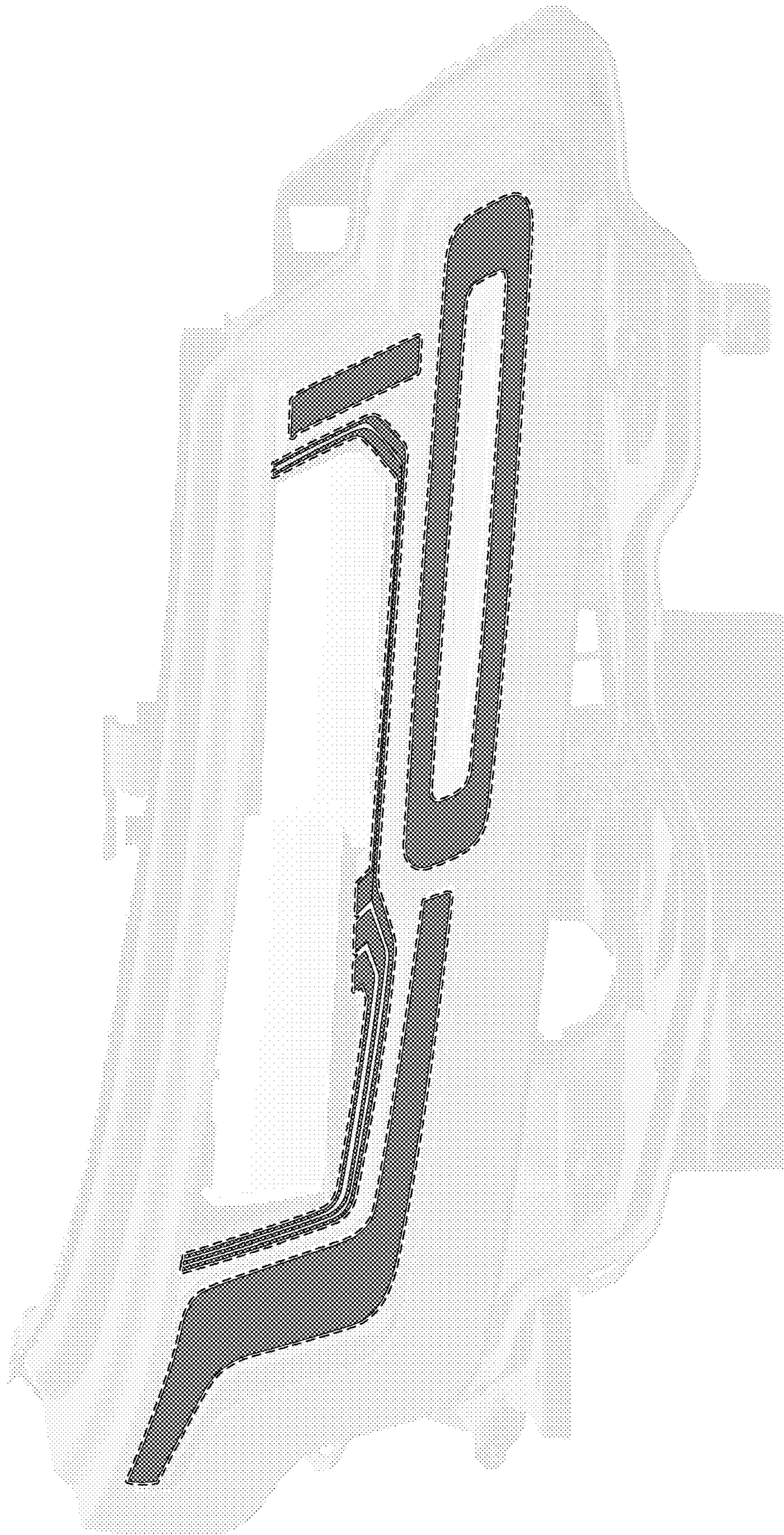

FIG. 3



FIG. 4

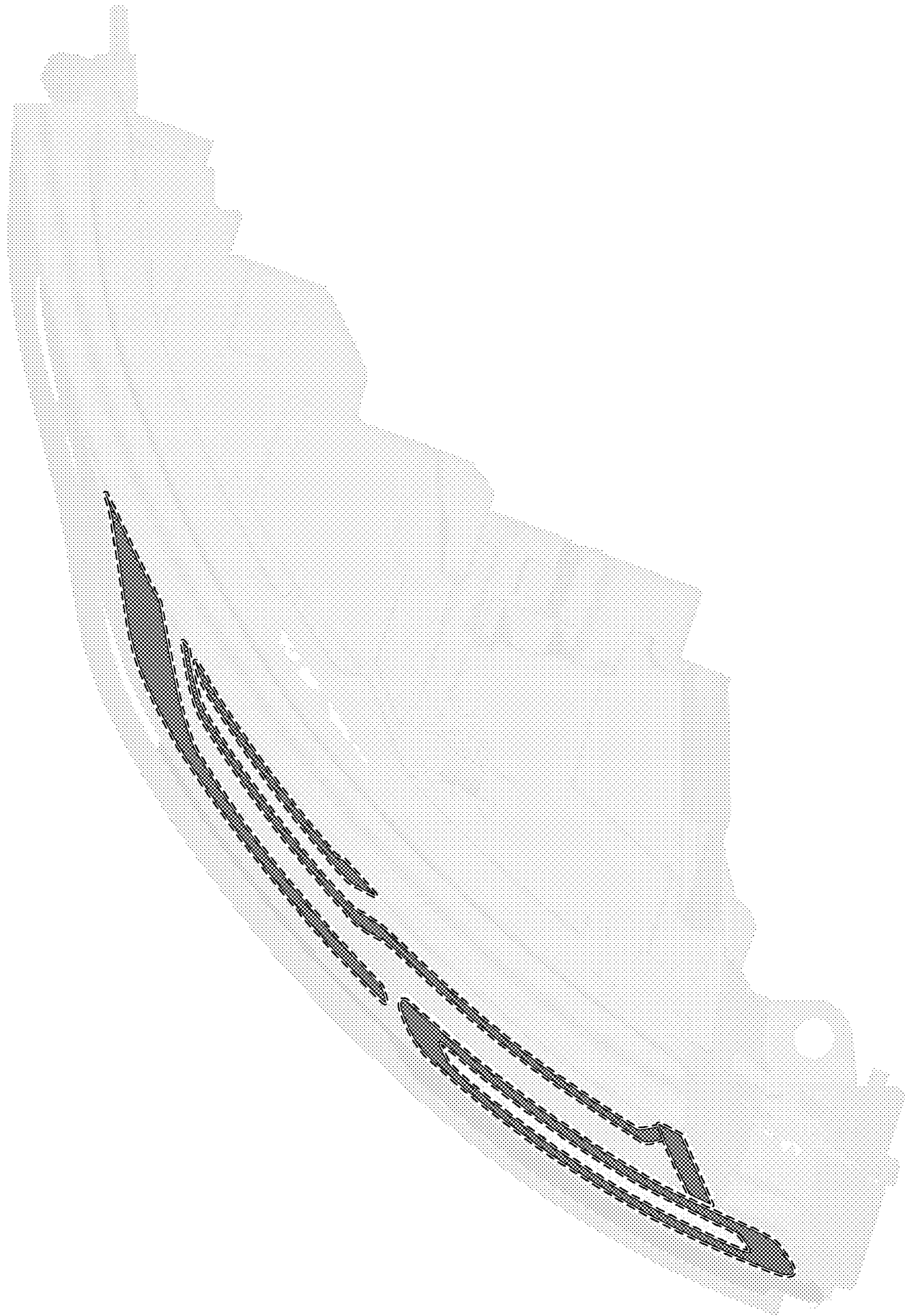

FIG. 5

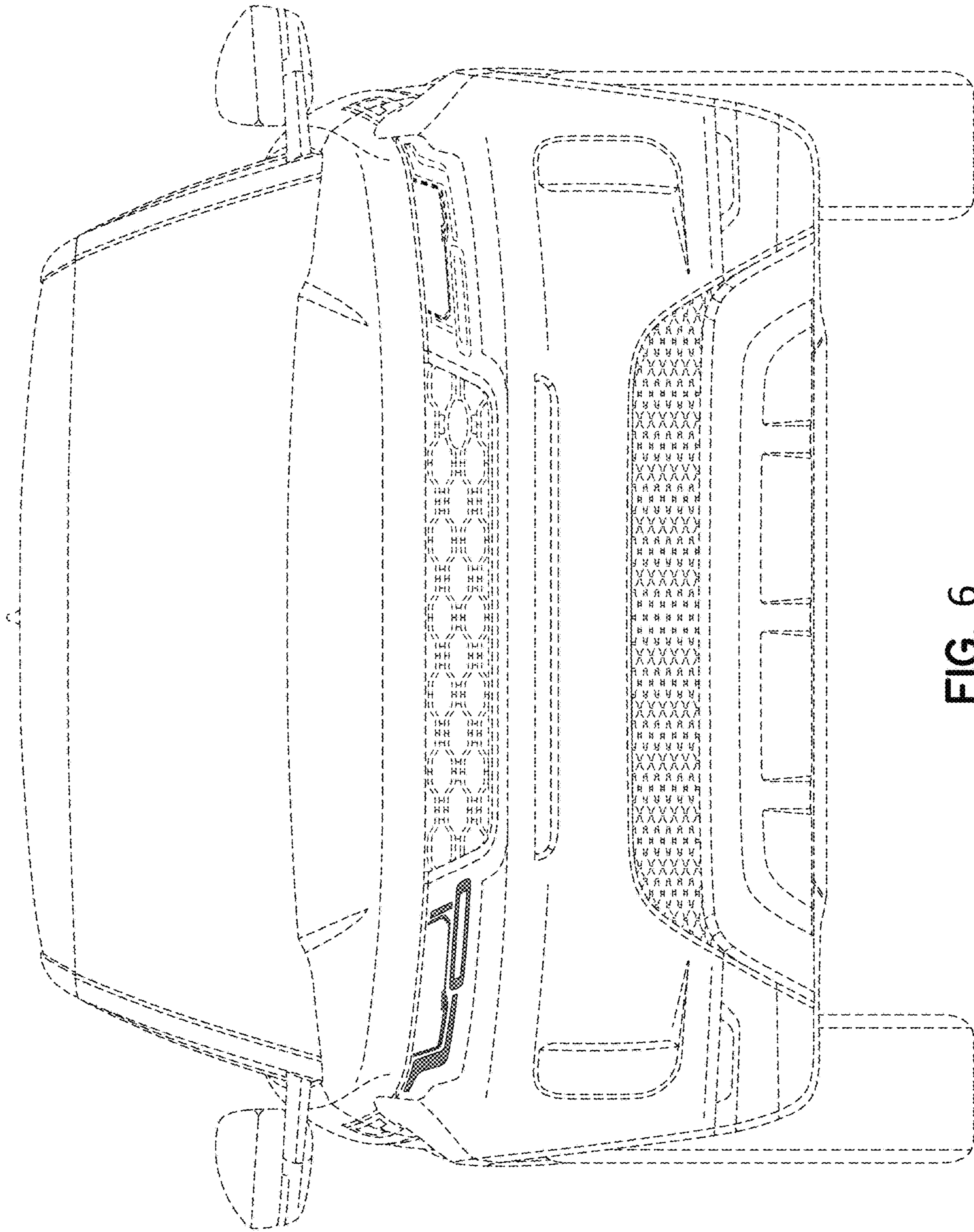

FIG. 6

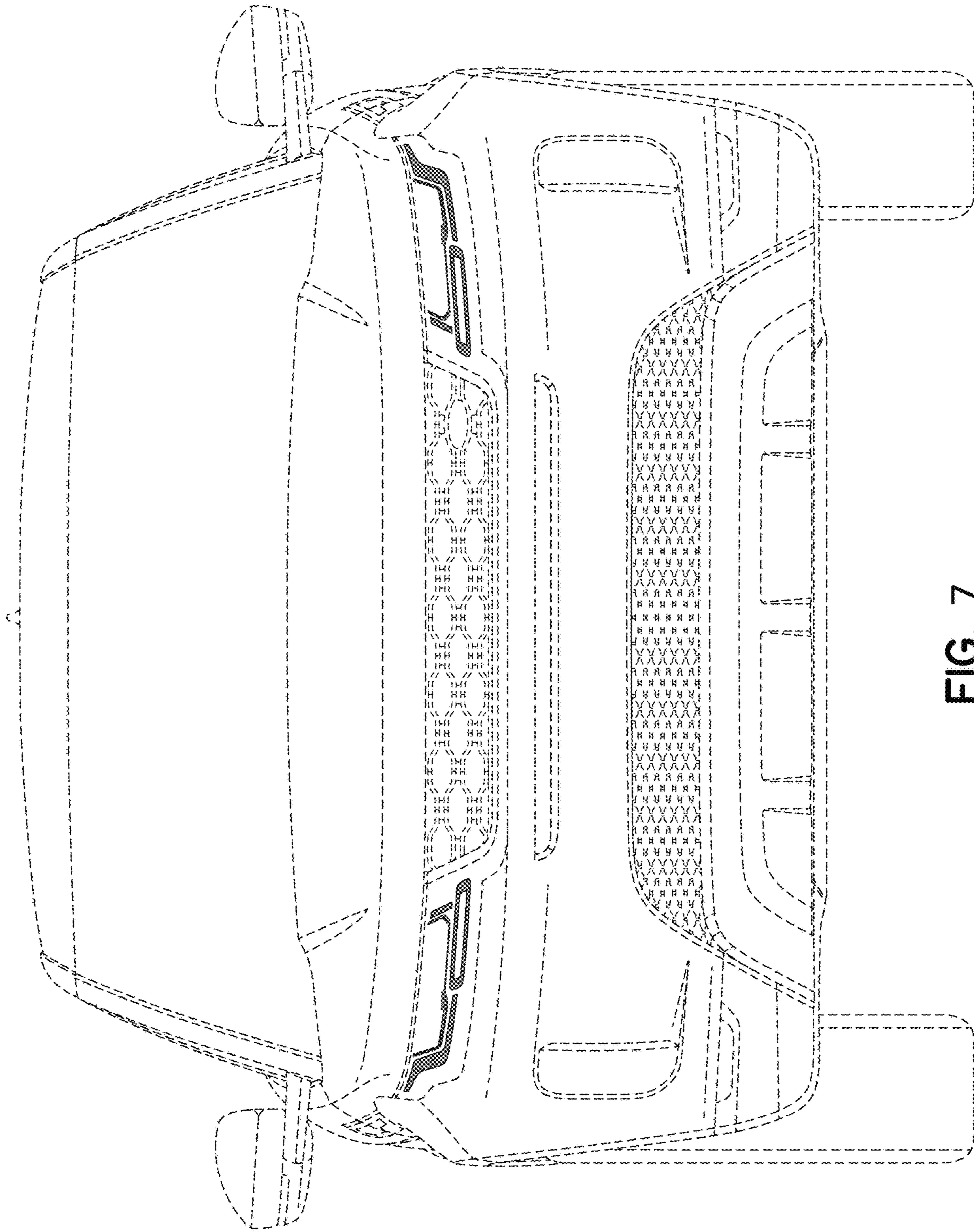

FIG. 7