



US00D928911S

(12) **United States Design Patent** (10) **Patent No.:** **US D928,911 S**
Huda et al. (45) **Date of Patent:** **** Aug. 24, 2021**

(54) **WATER PURIFICATION MEDIA DEVICE**
(71) Applicant: **Unger Marketing International, LLC**,
Bridgeport, CT (US)
(72) Inventors: **Stephen P. Huda**, Shelton, CT (US);
Kai Hirsch, Cologne (DE)
(73) Assignee: **UNGER MARKETING**
INTERNATIONAL, LLC, Bridgeport,
CT (US)

5,637,214 A 6/1997 Kahana
6,132,612 A 10/2000 Bourgeois
6,197,193 B1 3/2001 Archer
6,685,843 B2 2/2004 Leaverton
D506,551 S 6/2005 Booth et al.
7,014,690 B2 3/2006 Mitsch et al.
7,303,605 B2 12/2007 Zia et al.
D692,524 S 10/2013 Ziser
D740,915 S 10/2015 Harrington
D742,997 S * 11/2015 Sgroi, Jr. D23/207
(Continued)

(**) Term: **15 Years**

(21) Appl. No.: **29/764,043**

(22) Filed: **Dec. 28, 2020**

Related U.S. Application Data

(63) Continuation of application No. 29/693,663, filed on
Jun. 4, 2019, now Pat. No. Des. 913,413.

(51) **LOC (13) Cl.** **23-01**

(52) **U.S. Cl.**
USPC **D23/207**

(58) **Field of Classification Search**
USPC D23/207-209; D4/199; 55/369
CPC B01D 29/1134; B01D 29/0029; B01D
29/0097

See application file for complete search history.

(56) **References Cited**

U.S. PATENT DOCUMENTS

1,211,369 A 1/1917 Miller
1,834,978 A * 12/1931 Shapiro A61F 7/103
383/60
1,995,830 A * 3/1935 Barnsby A47L 9/149
55/369
2,278,488 A 4/1942 Ralston
4,932,915 A 6/1990 Boris et al.
5,154,823 A 10/1992 Ma et al.
5,595,652 A 1/1997 Rainer

FOREIGN PATENT DOCUMENTS

WO 2010010574 A1 1/2010
WO 2015157680 A1 10/2015

OTHER PUBLICATIONS

Ultra Resin Pack, announced Date unavailable[online], [site visited
Mar. 15, 2021]. Available from internet, URL:<<https://usa.ungerglobal.com/product/hydropower-ultra-resin-packs/>> (Year: 2021).*

(Continued)

Primary Examiner — Barbara Fox
Assistant Examiner — Jamaal Rasheed
(74) *Attorney, Agent, or Firm* — Cantor Colburn LLP

(57) **CLAIM**

The ornamental design for a water purification media device,
as shown and described.

DESCRIPTION

FIG. 1 is a front top perspective view of the design;
FIG. 2 is a front view of the design, the rear view and side
views being the same as the front view;
FIG. 3 is a top view of the design; and,
FIG. 4 is a bottom view of the design.
The dash dot lines represent boundary lines between claimed
and unclaimed subject matter.

1 Claim, 4 Drawing Sheets

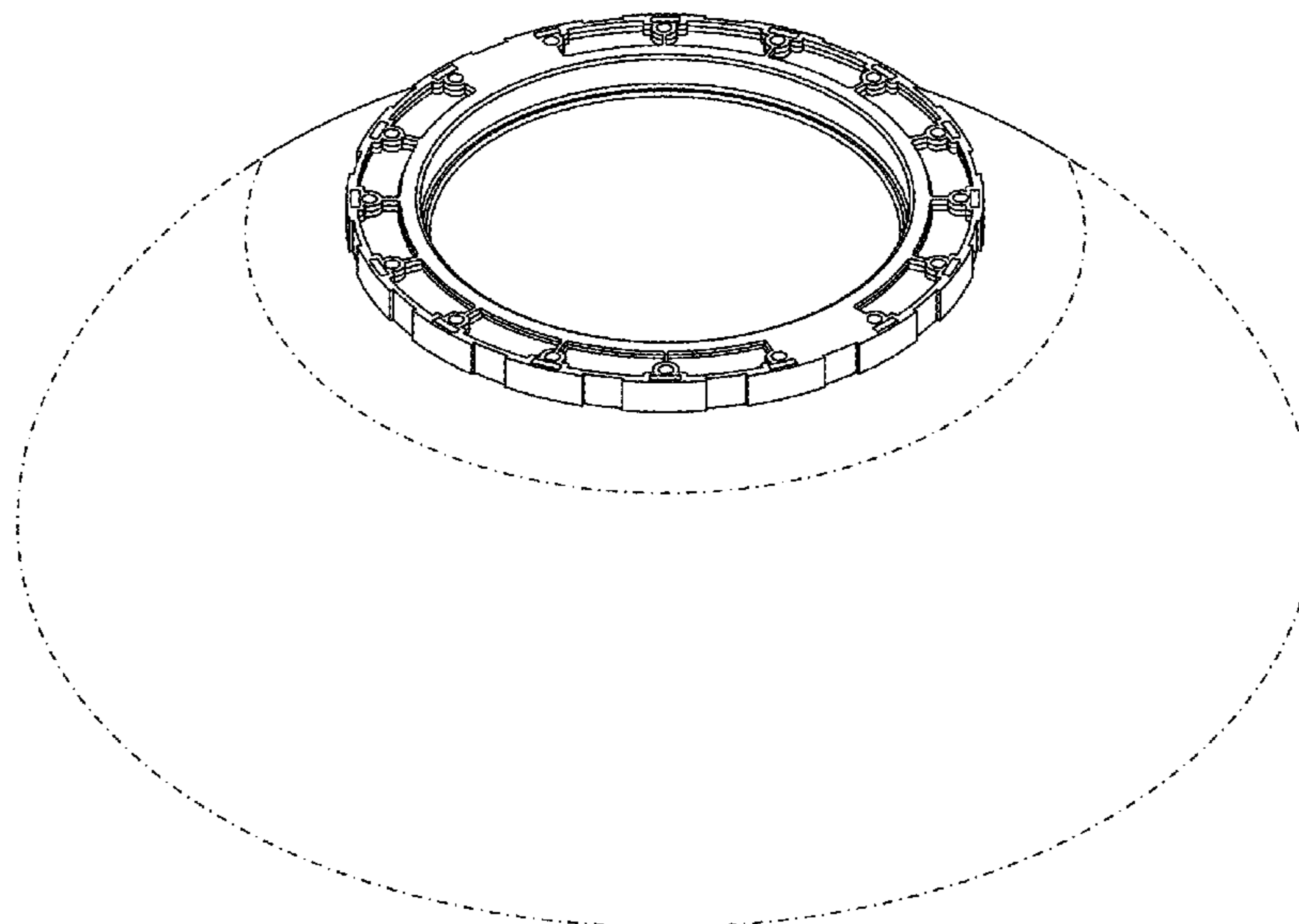

(56)

References Cited

U.S. PATENT DOCUMENTS

D798,996 S * 10/2017 Sgroi, Jr. D23/207
D828,488 S * 9/2018 Sgroi, Jr. D23/207
D851,412 S * 6/2019 Harrington A46B 9/06
D4/199
D894,326 S * 8/2020 Sommerfeld D23/207
2010/0012590 A1 1/2010 Slark
2012/0031142 A1* 2/2012 Marton A61F 7/02
62/530
2012/0132573 A1 5/2012 Lautzenheiser et al.
2012/0261329 A1 10/2012 Quintel
2013/0020246 A1 1/2013 Hoots et al.
2013/0158637 A1* 6/2013 Sheikh A61F 7/103
607/114
2018/0194646 A1 7/2018 Camp

OTHER PUBLICATIONS

Ultra Resin Pack, announced Date unavailable(online), [site visited Sep. 22, 2020]. Available from internet, URL:<https://usa.ungerglobal.com/product/hydroopower-ultra-resin-packs/> (Year: 2020).

* cited by examiner

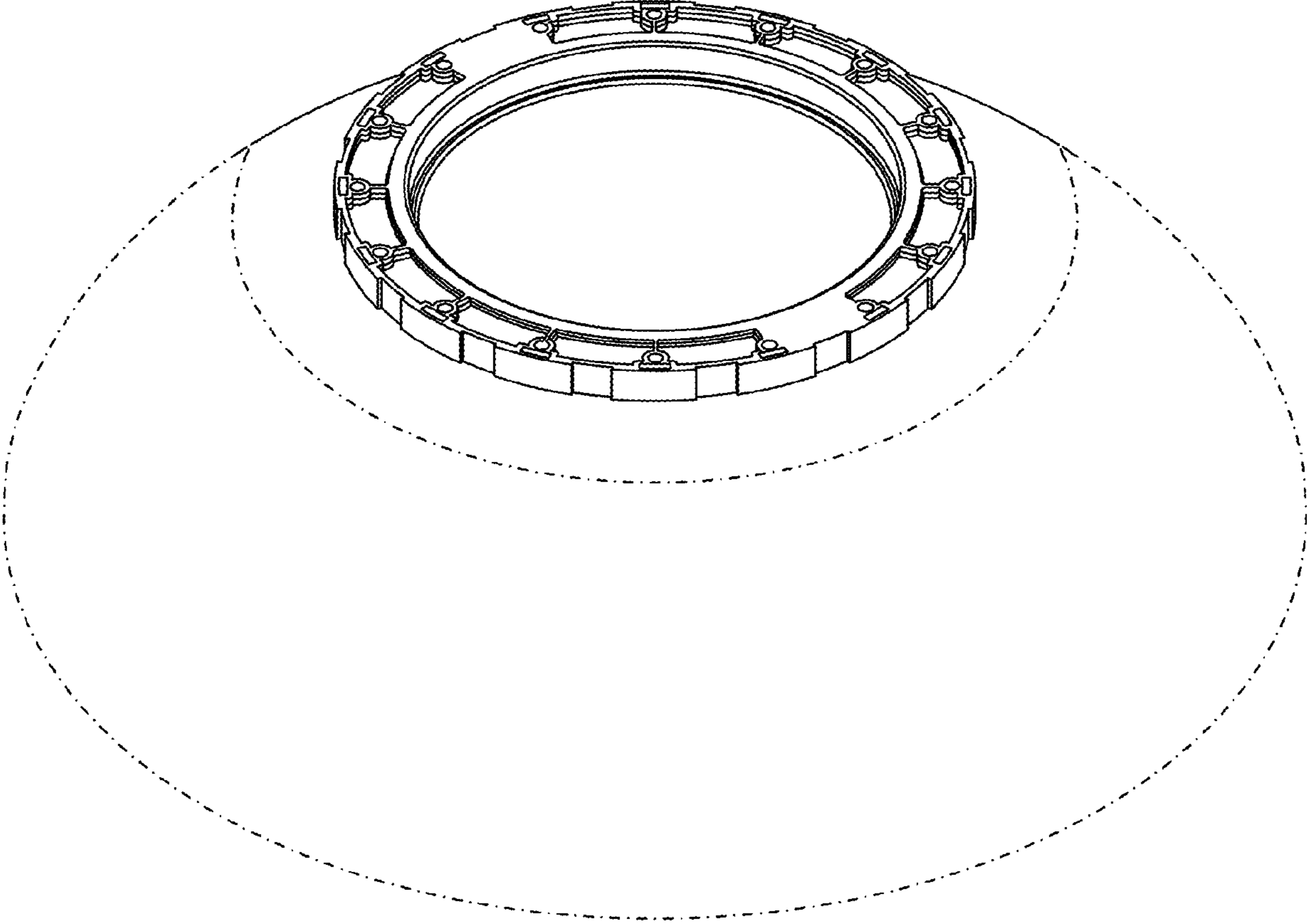

FIG. 1

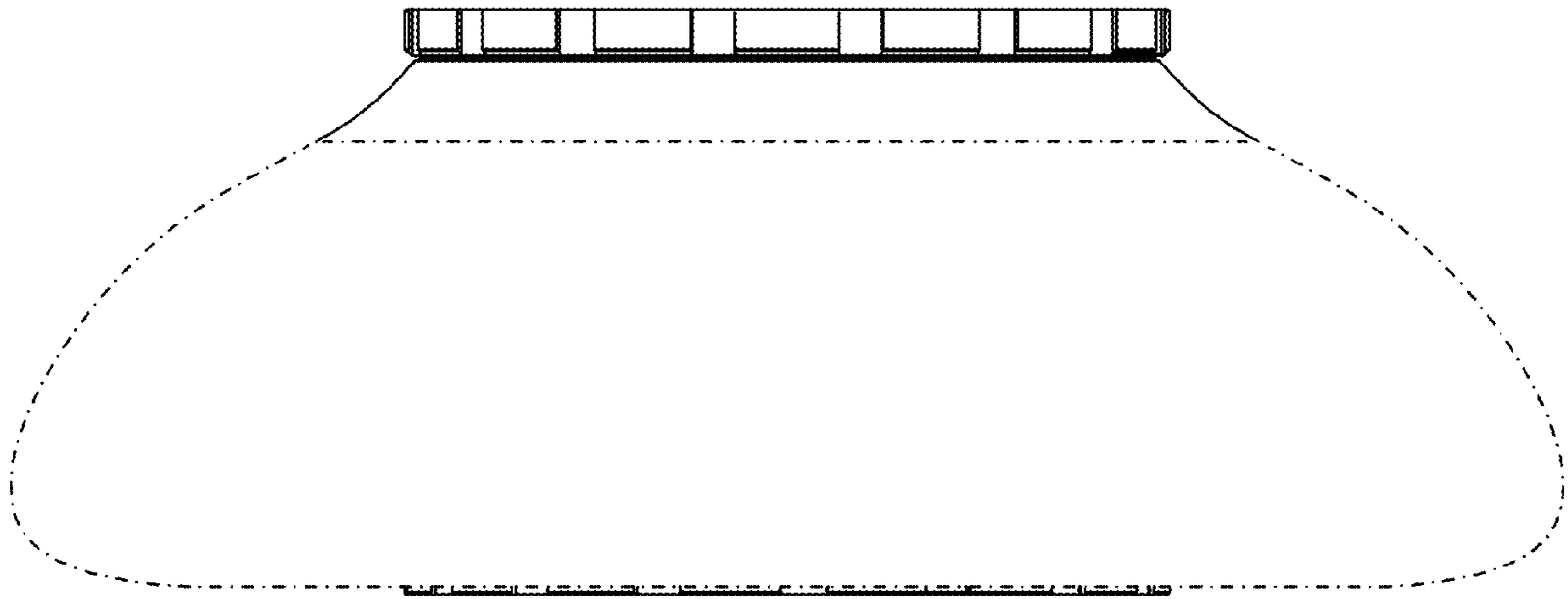

FIG. 2

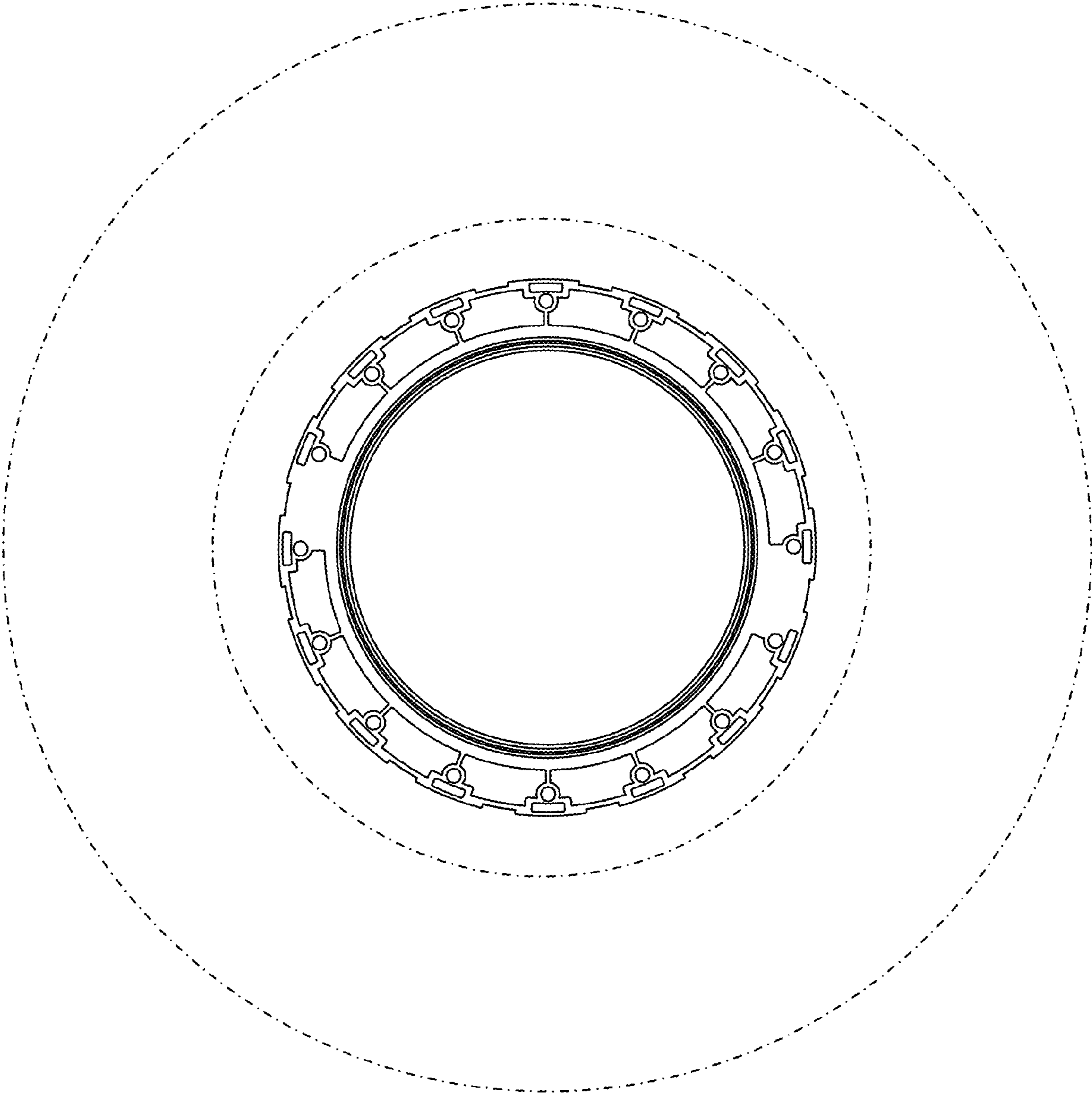

FIG. 3

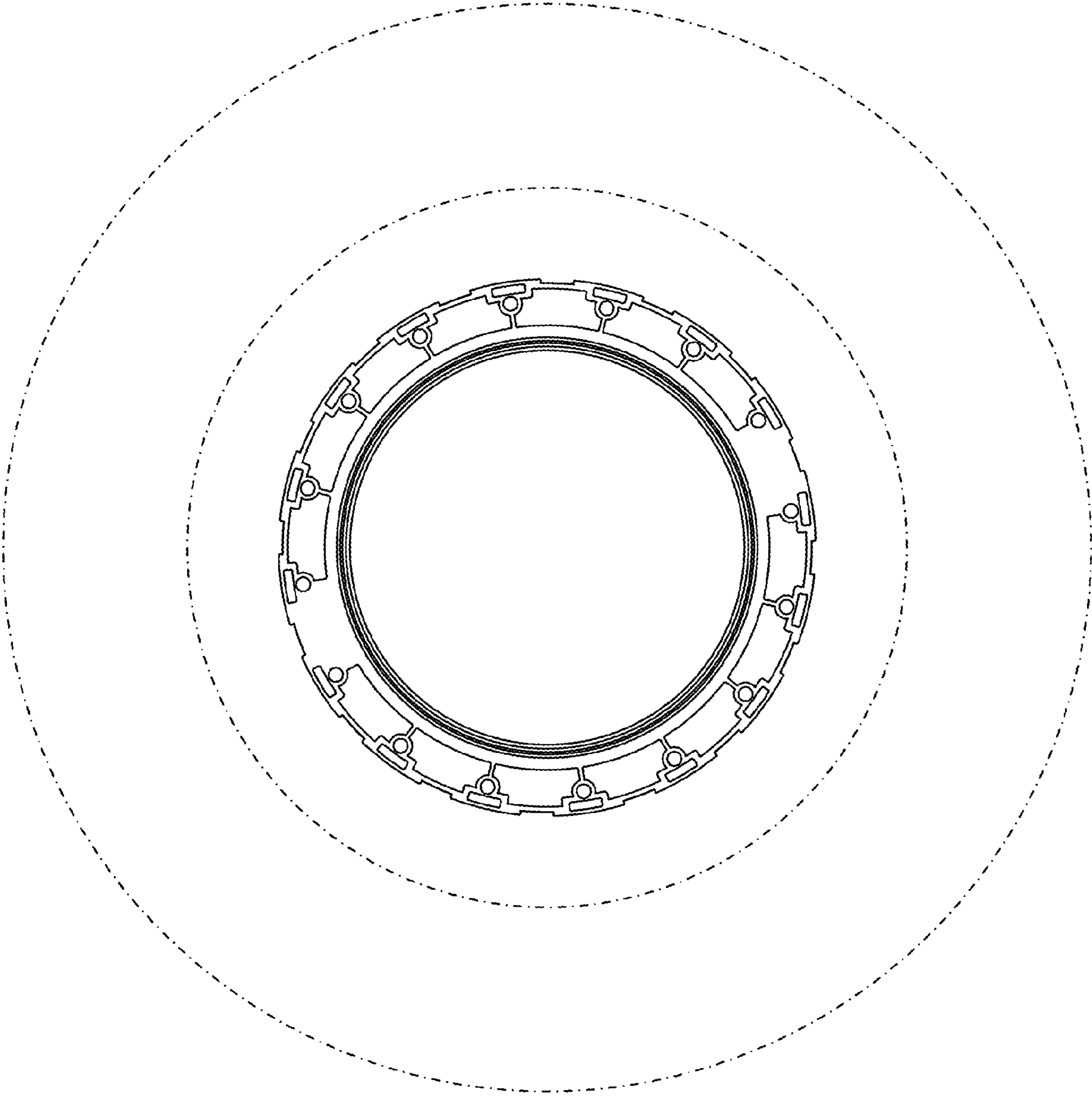

FIG. 4