



US00D928866S

(12) **United States Design Patent** (10) **Patent No.:** **US D928,866 S**  
**Wolff** (45) **Date of Patent:** **\*\* \*Aug. 24, 2021**

(54) **GUITAR STRAP LOCK ADAPTER**

(71) Applicant: **Music Nomad, LLC**, Sonoma, CA (US)

(72) Inventor: **Glen C. Wolff**, Lakeside, CA (US)

(73) Assignee: **Music Nomad LLC**, Sonoma, CA (US)

(\* ) Notice: This patent is subject to a terminal disclaimer.

(\*\*) Term: **15 Years**

(21) Appl. No.: **29/673,468**

(22) Filed: **Dec. 14, 2018**

(51) **LOC (13) Cl.** ..... **17-03**

(52) **U.S. Cl.**  
USPC ..... **D17/20**

(58) **Field of Classification Search**  
USPC ..... D17/14, 18, 19, 20, 21, 99; D21/405  
CPC .. G10D 1/08; G10D 1/10; G10D 3/00; G10D 3/04; G10D 3/16; G10D 3/163; G10D 3/18; G10G 5/005; G10H 1/348; G09B 15/00  
See application file for complete search history.

(56) **References Cited**

**U.S. PATENT DOCUMENTS**

4,993,127 A \* 2/1991 Mechem ..... A45C 13/30  
224/257  
7,818,851 B2 \* 10/2010 Perrotta ..... A45F 3/14  
24/265 BC

D790,623 S \* 6/2017 Wang ..... D17/2  
D852,649 S \* 7/2019 Burns ..... D10/46  
2005/0284282 A1 \* 12/2005 D'Addario ..... G10G 5/005  
84/327  
2019/0244591 A1 \* 8/2019 Bodnar ..... A44B 99/00

**FOREIGN PATENT DOCUMENTS**

GB 2182092 A \* 5/1987 ..... A45C 13/30  
WO WO-2008083410 A1 \* 7/2008 ..... G10G 5/005

\* cited by examiner

*Primary Examiner* — R. Johnson

(74) *Attorney, Agent, or Firm* — Bond Schoeneck & King, PLLC; George McGuire

(57) **CLAIM**

The ornamental design for a guitar strap lock adapter, as shown and described.

**DESCRIPTION**

FIG. 1 is a top perspective view of a guitar strap lock adapter showing my new design;  
FIG. 2 is a top plan view thereof;  
FIG. 3 is a bottom plan view thereof;  
FIG. 4 is a first side elevation view thereof;  
FIG. 5 is a second side elevation view thereof;  
FIG. 6 is a front elevation view thereof;  
FIG. 7 is a rear elevation view thereof; and,  
FIG. 8 is a perspective view showing the guitar strap lock adapter attached to and securing a guitar strap to the guitar. The broken lines in FIGS. 1-8 illustrate environment only and form no part of the claimed design.

**1 Claim, 8 Drawing Sheets**

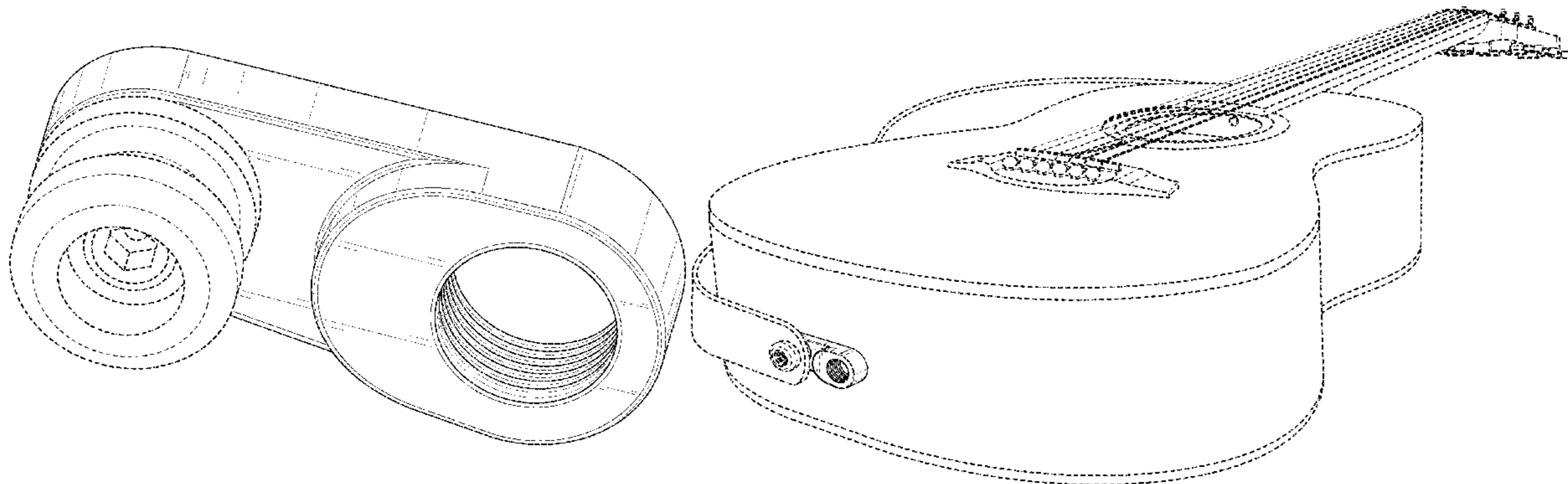

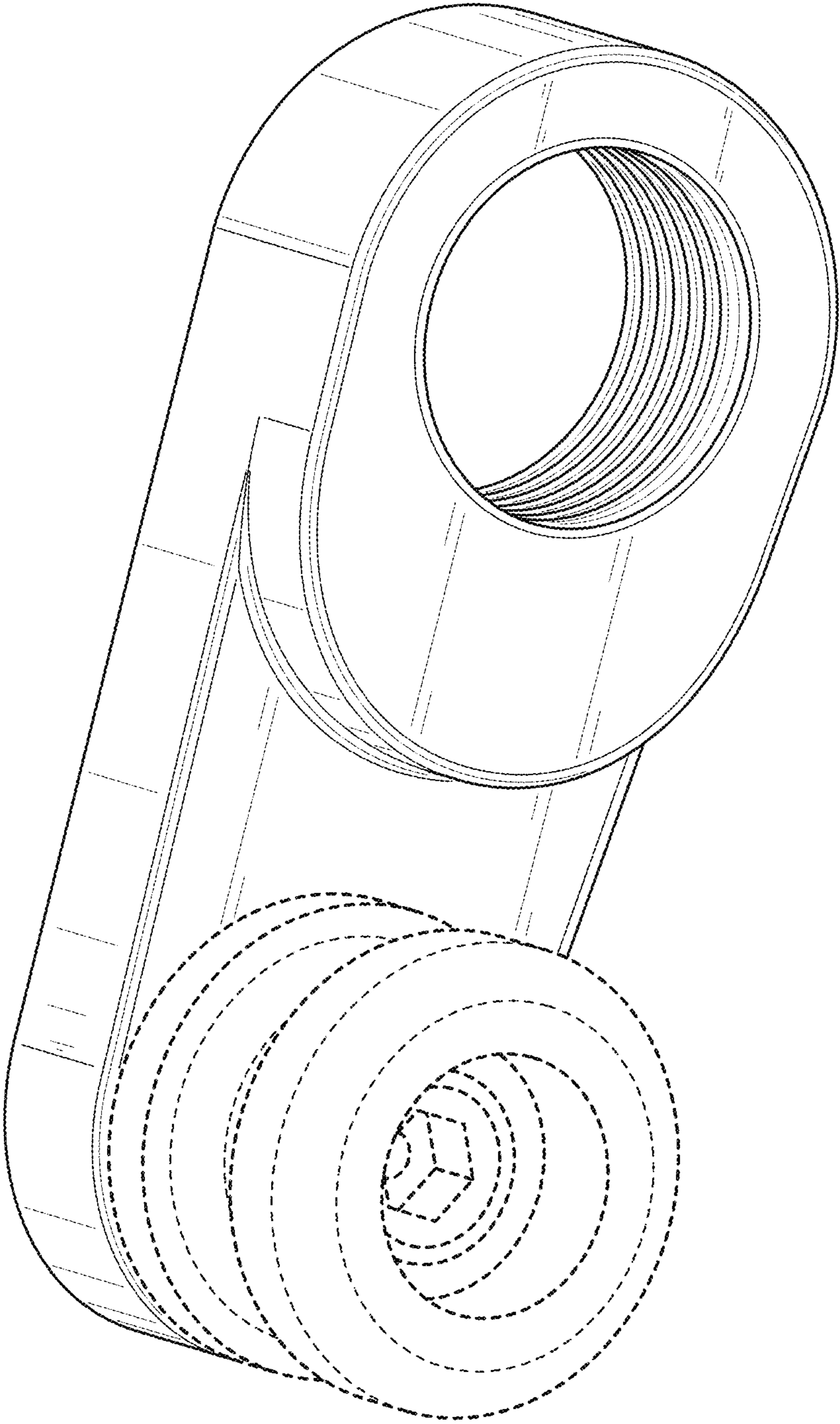

FIG. 1

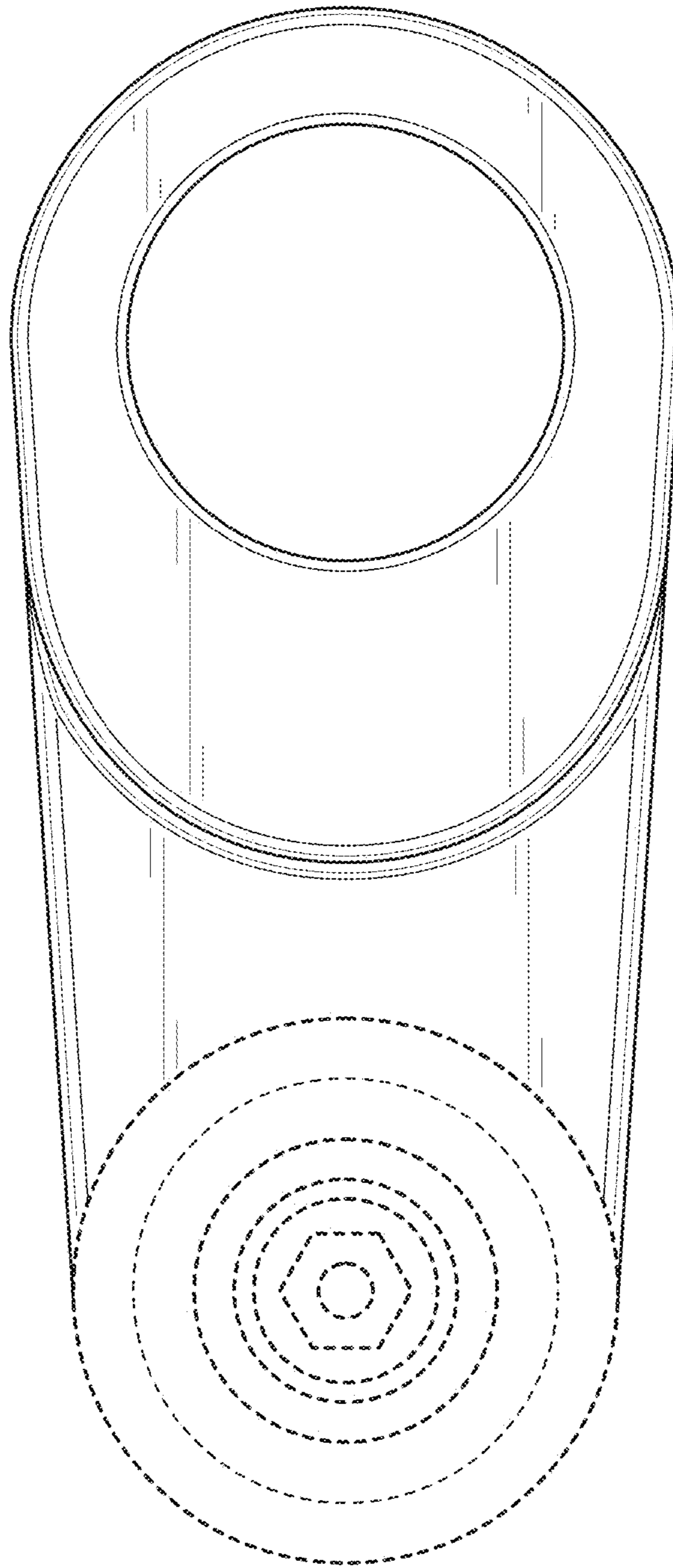

FIG. 2

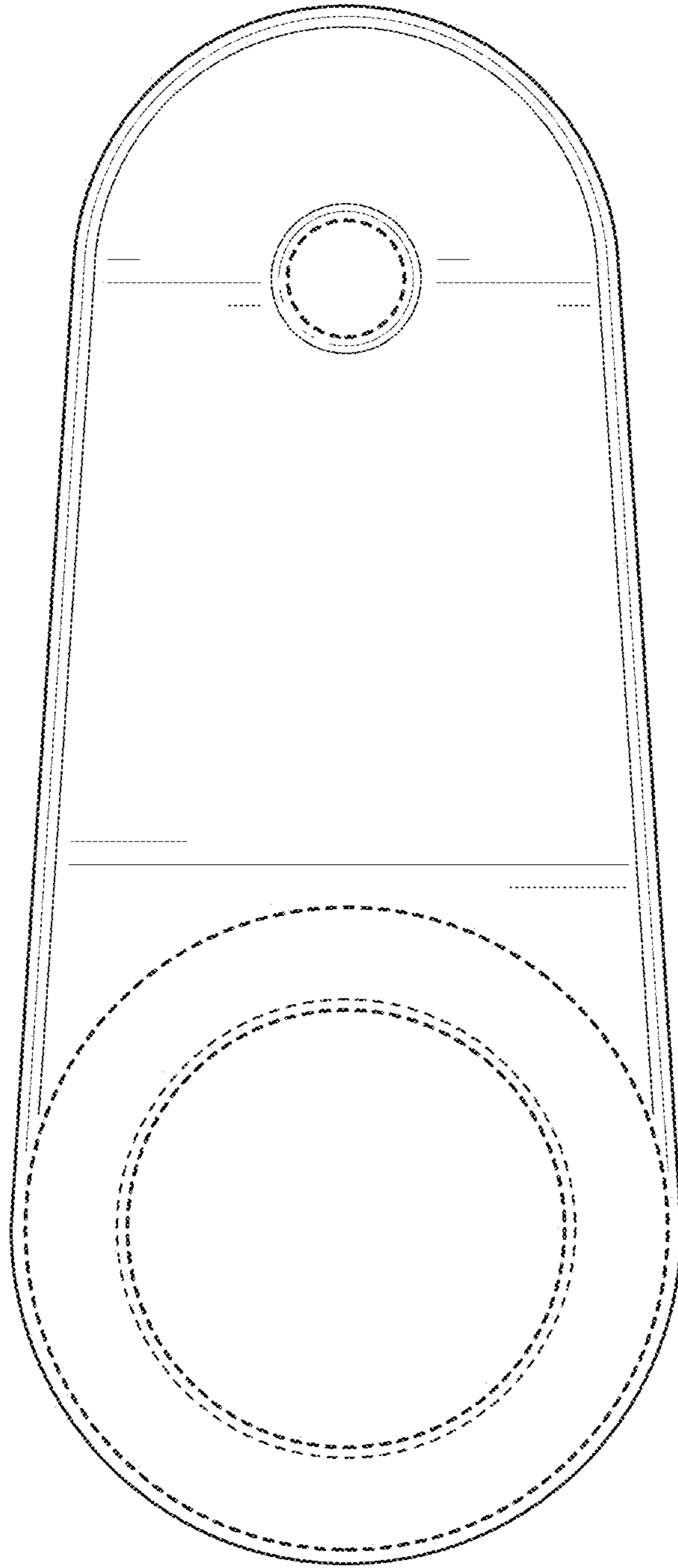

FIG. 3

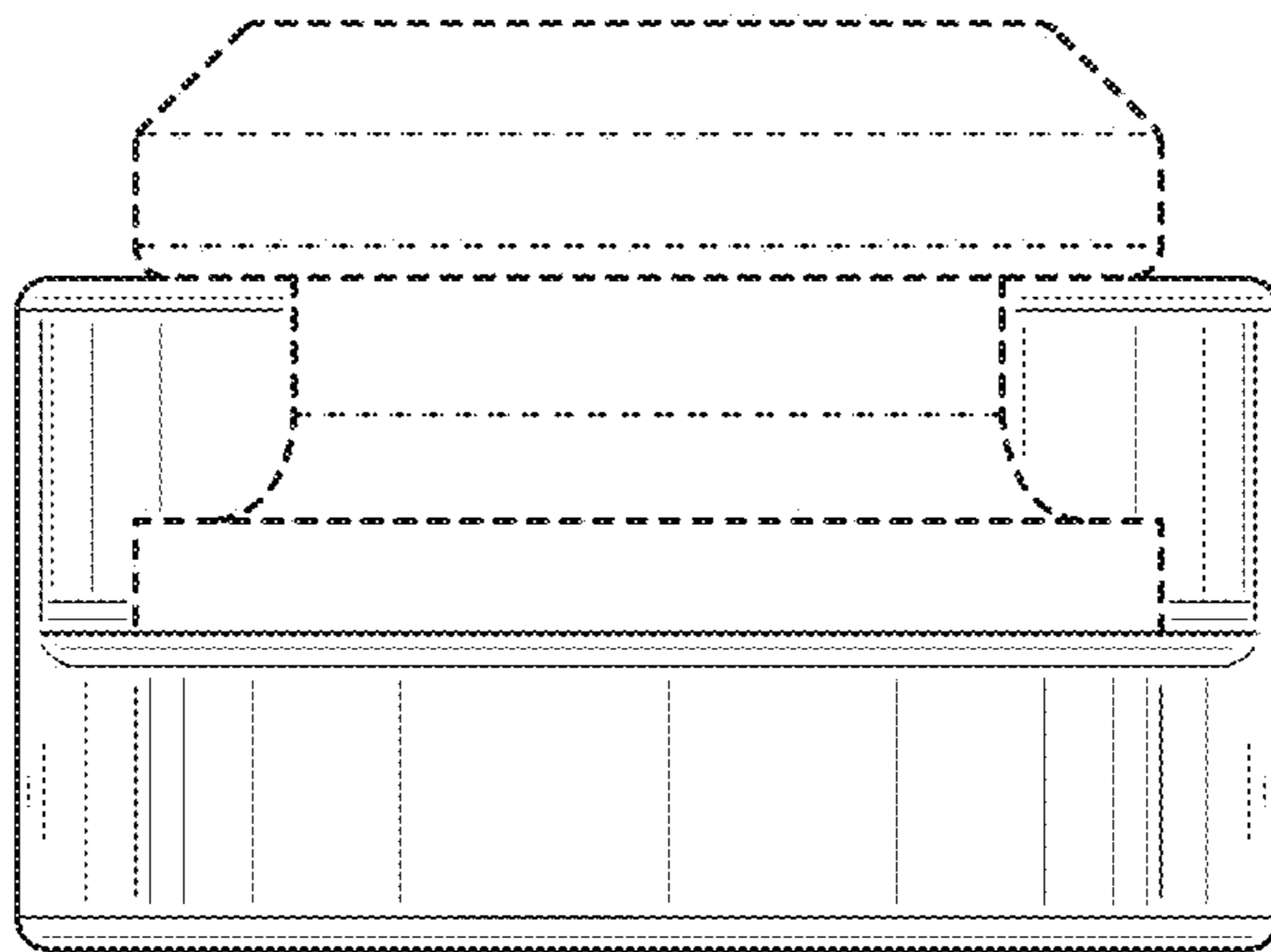

FIG. 4

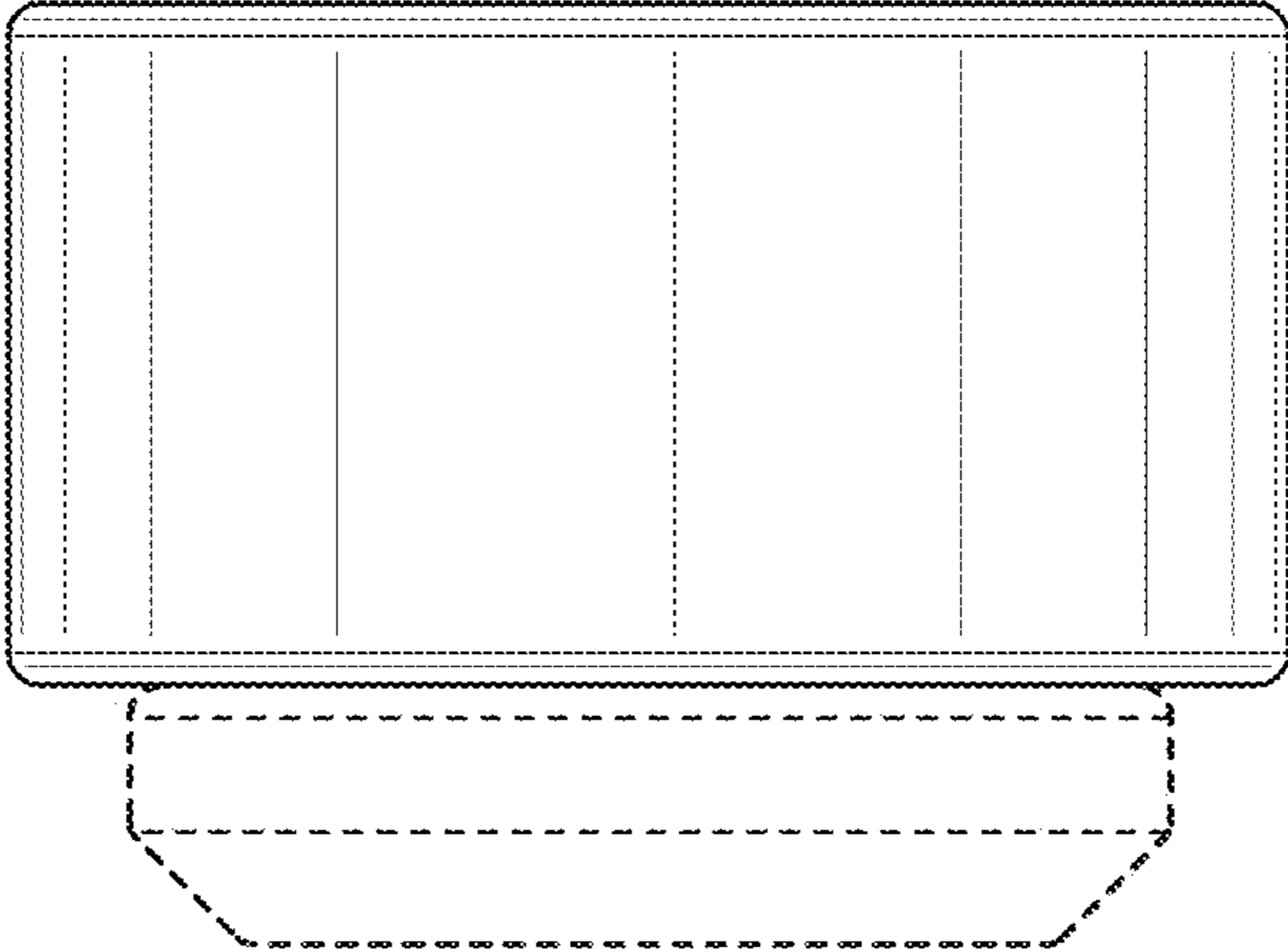

FIG. 5

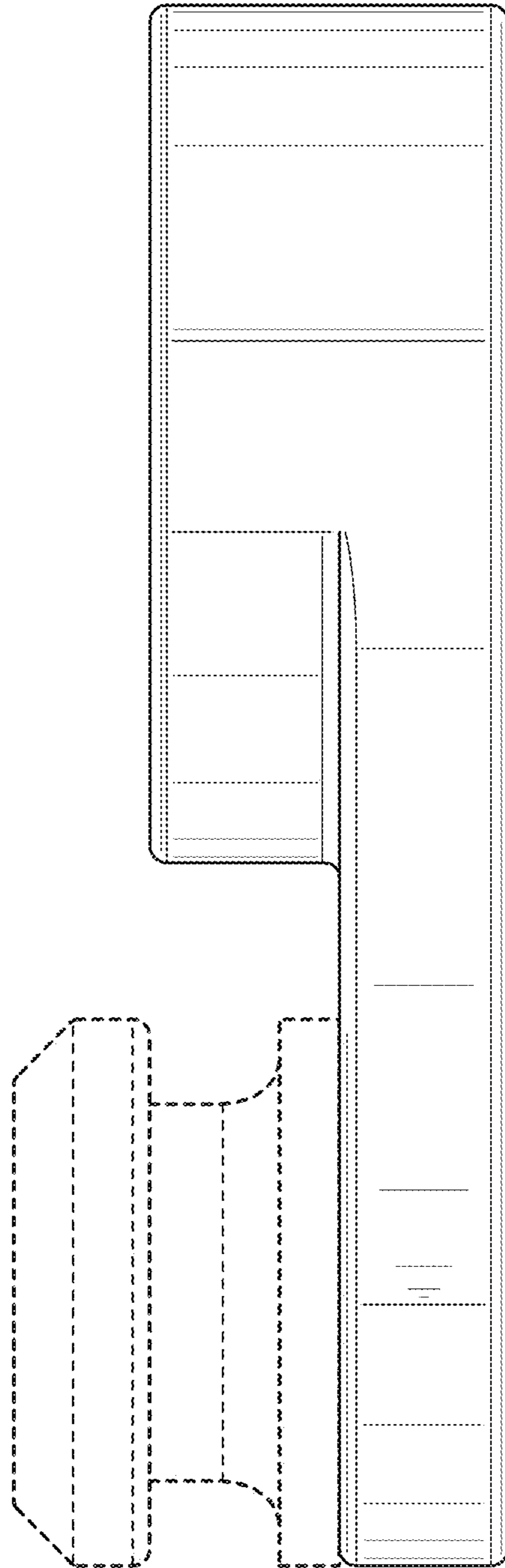

FIG. 6

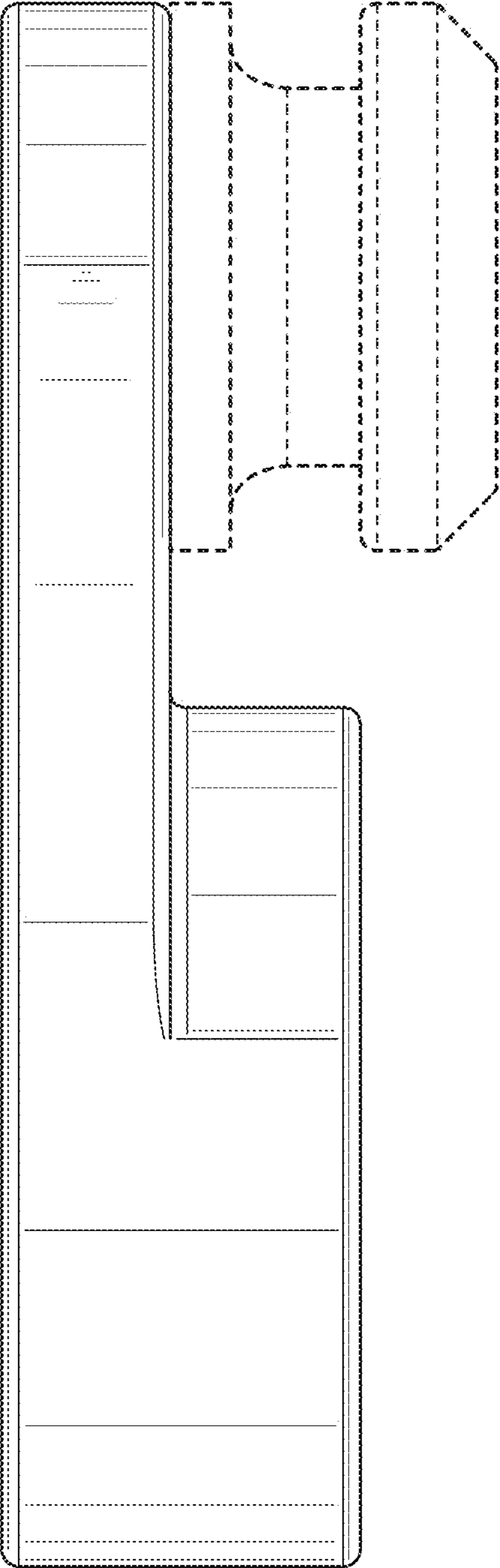

FIG. 7



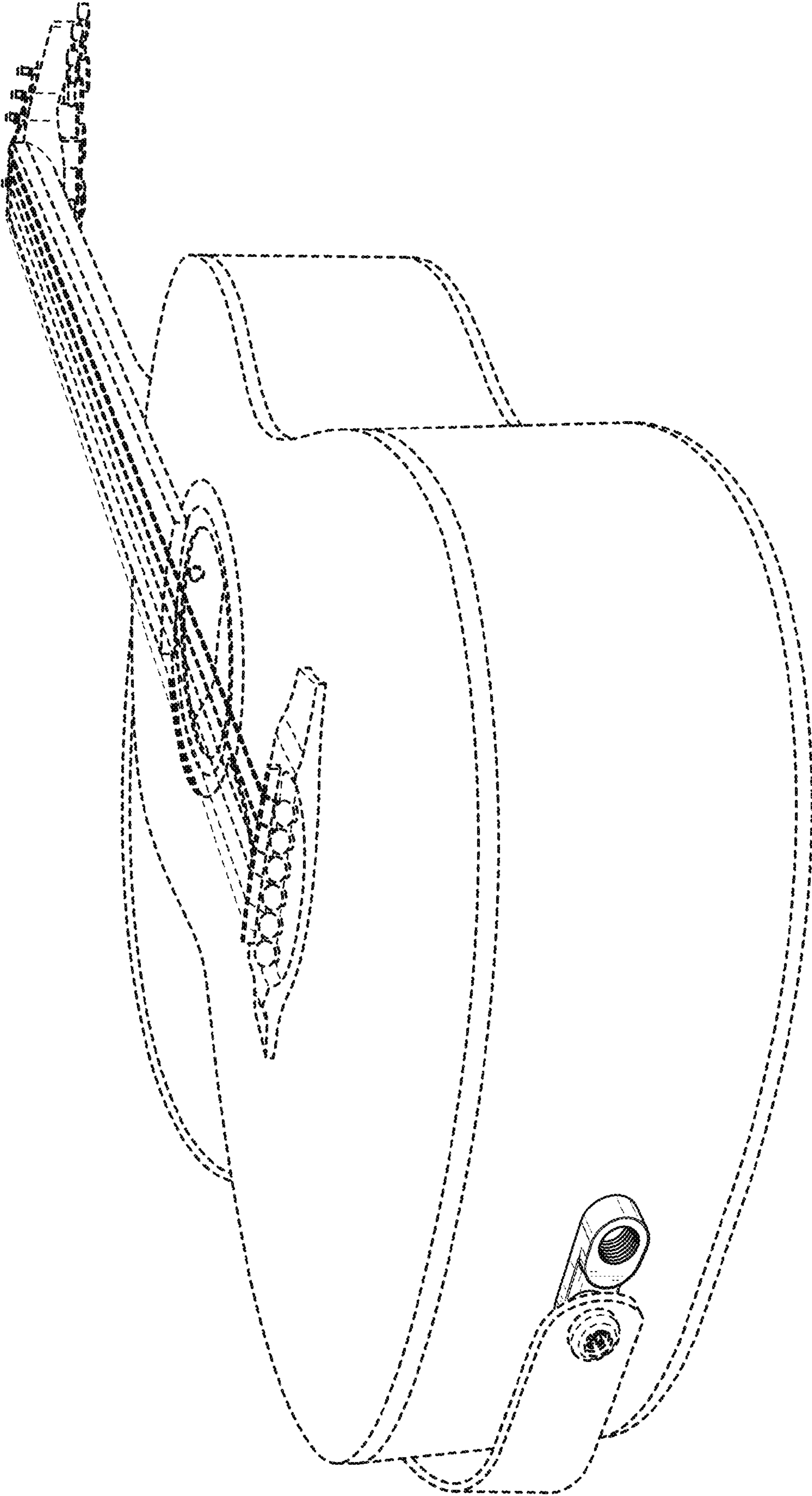

FIG. 8