



US00D928671S

(12) **United States Design Patent** (10) **Patent No.:** **US D928,671 S**
Andoh (45) **Date of Patent:** **** Aug. 24, 2021**

(54) **FRONT GRILLE FOR AN AUTOMOBILE**

(71) Applicant: **Subaru Corporation**, Tokyo (JP)

(72) Inventor: **Takahiro Andoh**, Tokyo (JP)

(73) Assignee: **Subaru Corporation**, Tokyo (JP)

(**) Term: **15 Years**

(21) Appl. No.: **29/727,802**

(22) Filed: **Mar. 13, 2020**

(30) **Foreign Application Priority Data**

Sep. 13, 2019 (JP) 2019-020560

(51) **LOC (13) Cl.** **12-16**

(52) **U.S. Cl.**
USPC **D12/163**

(58) **Field of Classification Search**
USPC D12/163, 164, 165, 166, 167, 168, 169,
D12/170, 171, 172, 173, 181
CPC B60K 11/08; B62L 39/16; B60R 19/50;
B62D 25/08
See application file for complete search history.

(56) **References Cited**

U.S. PATENT DOCUMENTS

D575,687 S *	8/2008	Hatake	D12/163
D575,689 S *	8/2008	Chang	D12/163
D579,829 S *	11/2008	Hokao	D12/163
D592,563 S *	5/2009	Asakura	D12/163
D597,898 S *	8/2009	Nakamura	D12/163
D625,670 S *	10/2010	Roller	D12/163
D726,079 S *	4/2015	Reichman	D12/163
D805,005 S *	12/2017	Tomita	D12/163
D811,953 S *	3/2018	Seol	D12/163
D819,506 S *	6/2018	Han	D12/163
D821,932 S *	7/2018	Andoh	D12/163
D824,297 S *	7/2018	Janssen	D12/164
D827,509 S *	9/2018	Behmer	D12/163
D844,500 S *	4/2019	Metros	D12/163

D855,502 S *	8/2019	Behmer	D12/163
D858,372 S *	9/2019	Betancourt	D12/163
D863,145 S *	10/2019	Woodhouse	D12/164
D866,413 S *	11/2019	Luke	D12/163
D868,640 S *	12/2019	DiCanzio	D12/163
D869,350 S *	12/2019	Bucher	D12/163
D870,000 S *	12/2019	Joudo	D12/163
D878,255 S *	3/2020	Tonello	D12/163
D880,378 S *	4/2020	Lu	D12/163
D887,913 S *	6/2020	Scott	D12/164

(Continued)

OTHER PUBLICATIONS

Flierl, Denis. "Meet the 2021 Subaru Impreza—One Trim Level is Still the Best value." Sep. 4, 2020. Torque News, <https://www.torquenews.com/1084/meet-2021-subaru-impreza-one-trim-level-still-best-value>.*

(Continued)

Primary Examiner — Brett Miller
Assistant Examiner — Suzanne E Tisdell
(74) *Attorney, Agent, or Firm* — Schiff Hardin LLP

(57) **CLAIM**

I claim the ornamental design for a front grille for an automobile, as shown and described.

DESCRIPTION

FIG. 1 is a front perspective view for a "front grille for an automobile" showing our new design, FIG. 2 is a rear perspective view thereof, FIG. 3 is a front view thereof, FIG. 4 is a rear view thereof, FIG. 5 is a top view thereof, FIG. 6 is a bottom view thereof, FIG. 7 is a left-side view thereof, FIG. 8 is a right-side view thereof; and, FIG. 9 is an enlarged view taken along the line 9-9 of FIG. 3 thereof.

1 Claim, 5 Drawing Sheets

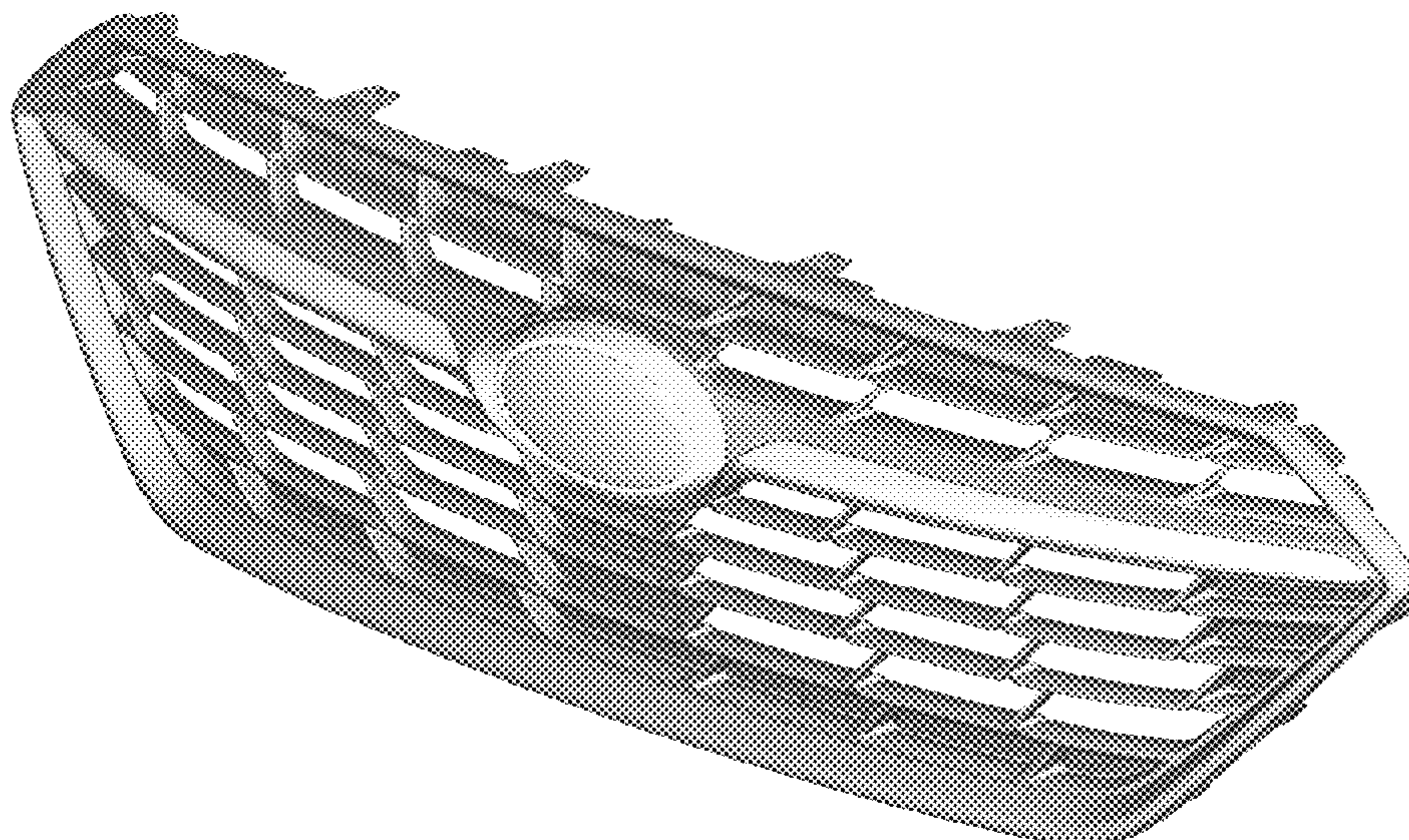

(56)

References Cited

U.S. PATENT DOCUMENTS

D888,623	S	*	6/2020	Vidojkovic	D12/164
D889,325	S	*	7/2020	Geoppel	D12/163
D891,315	S	*	7/2020	Metros	D12/163
D893,360	S	*	8/2020	Escobedo	D12/163
D893,364	S	*	8/2020	Gillam	D12/164
D894,059	S	*	8/2020	Mai	D12/163
D902,092	S	*	11/2020	Park	D12/163
D903,543	S	*	12/2020	Myrberg	D12/163
D906,190	S	*	12/2020	Wraith	D12/163
D906,191	S	*	12/2020	Han	D12/163
D907,538	S	*	1/2021	Gittin, Jr.	D12/163
D908,050	S	*	1/2021	Gittin, Jr.	D12/163
D908,551	S	*	1/2021	Choi	D12/163
D909,260	S	*	2/2021	De Rudnicki	D12/163
2011/0133498	A1	*	6/2011	Huang-Tsai	B60R 19/52 293/115

OTHER PUBLICATIONS

“The New 2021 Subaru Impreza, Built For Your Next Adventure.” Accessed Feb. 10, 2021. Carter Subaru Shoreline, <https://www.cartersubarushoreline.com/2021-subaru-impreza-launch.htm>.*

Courtney, Will Sabel. “This New Subaru Wagon Could Be Our Best Look Yet at the Next WRX.” Aug. 20, 2020. Gear Patrol. <https://www.gearpatrol.com/cars/a33656056/subaru-levorg-sti-look-next-wrx-preview/>.*

* cited by examiner

Fig. 1

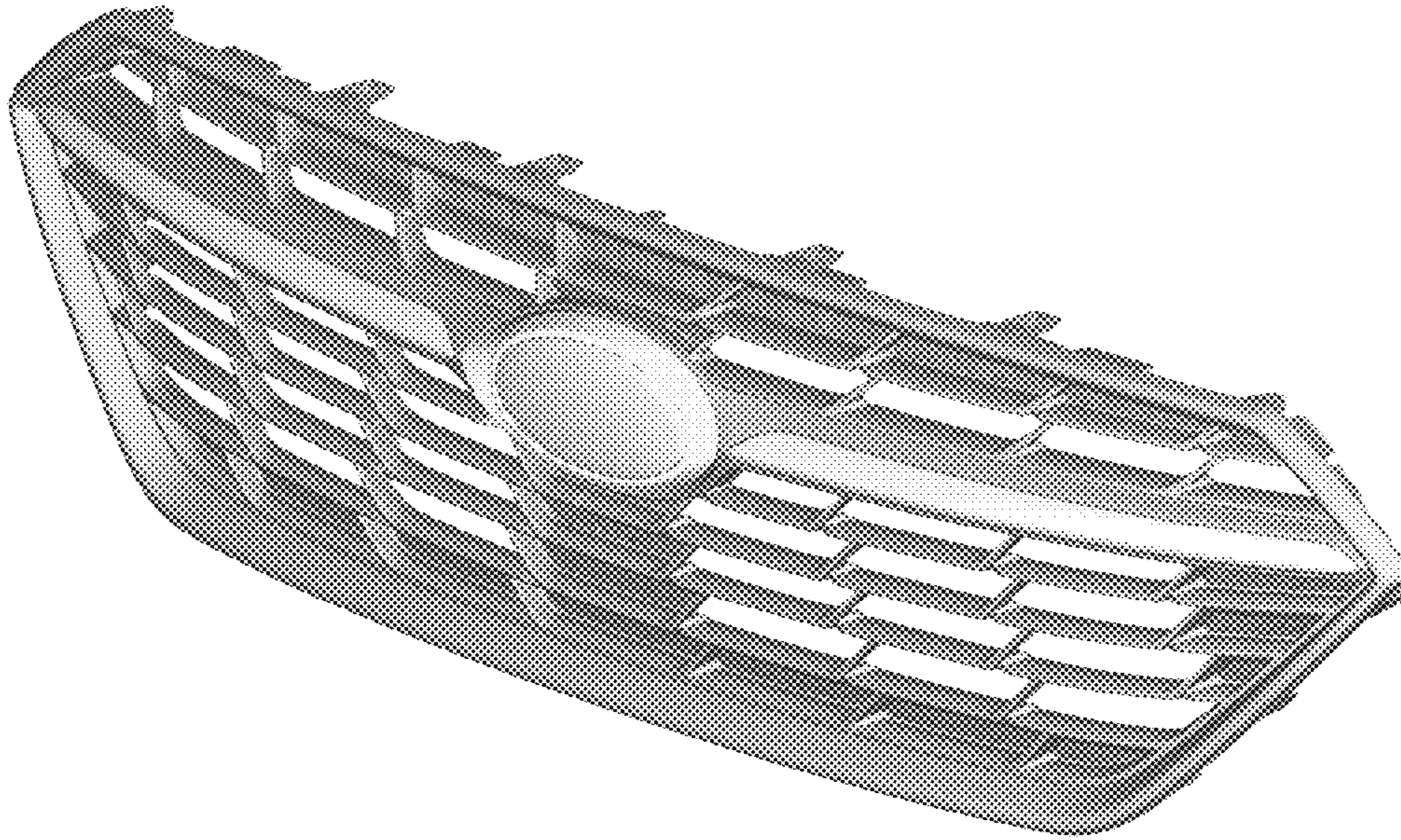

Fig. 2

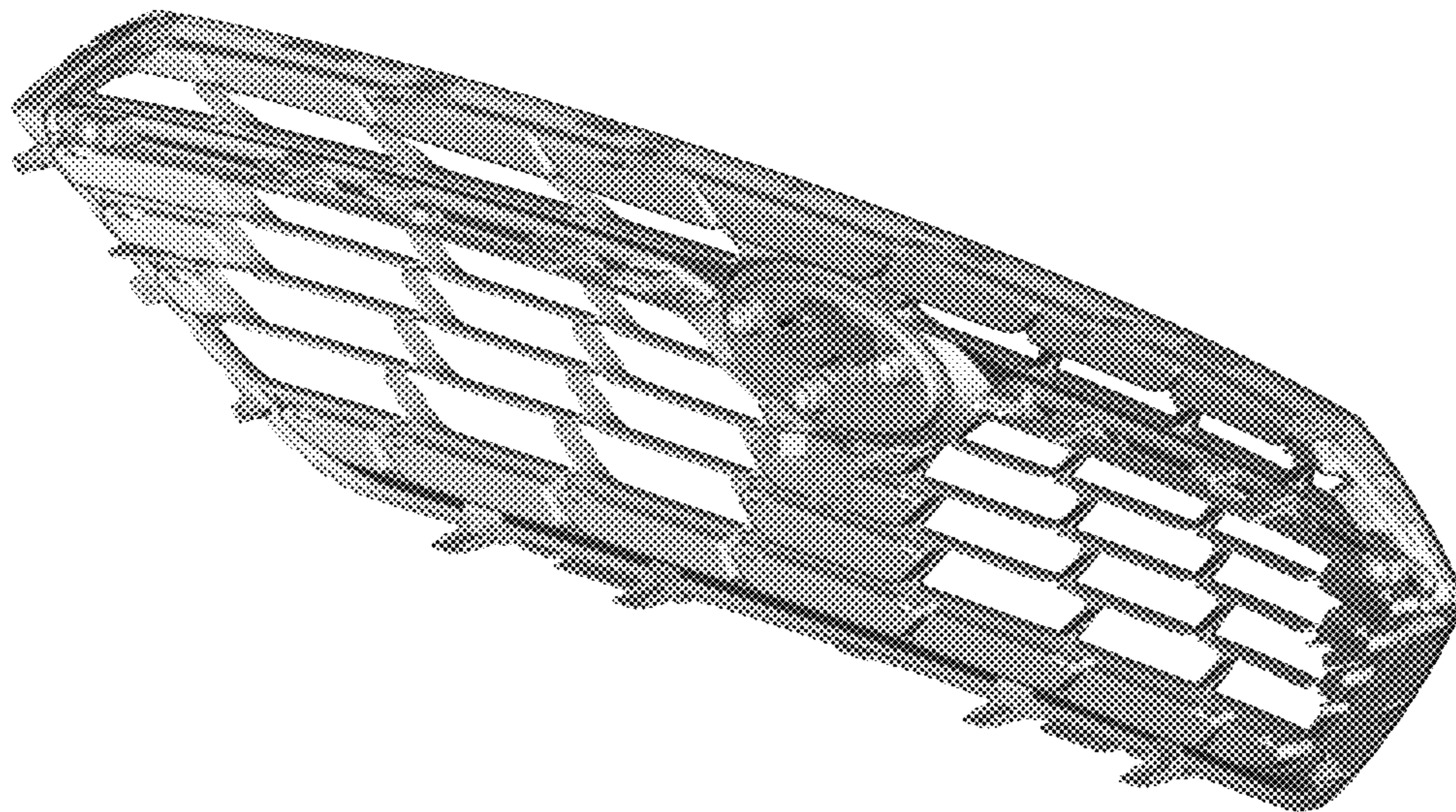

Fig. 3

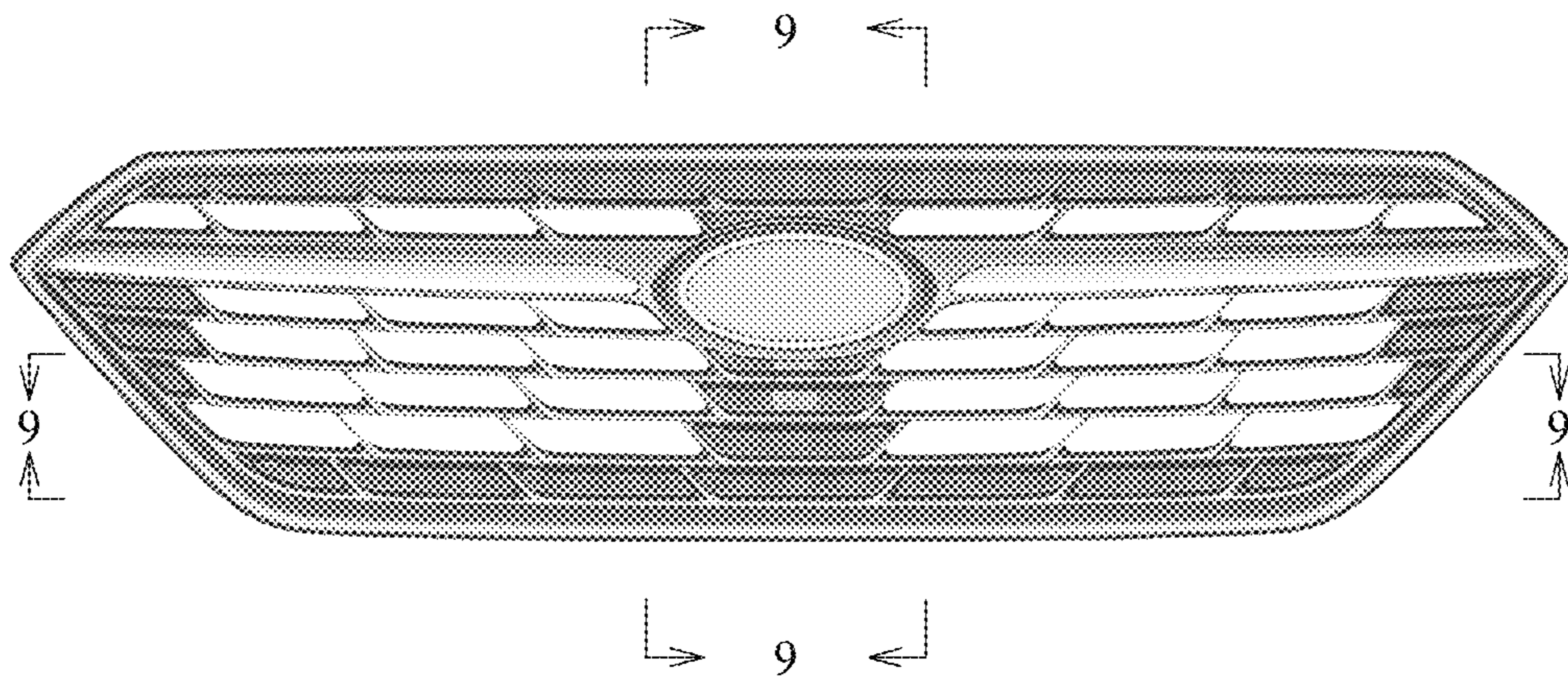

Fig. 4

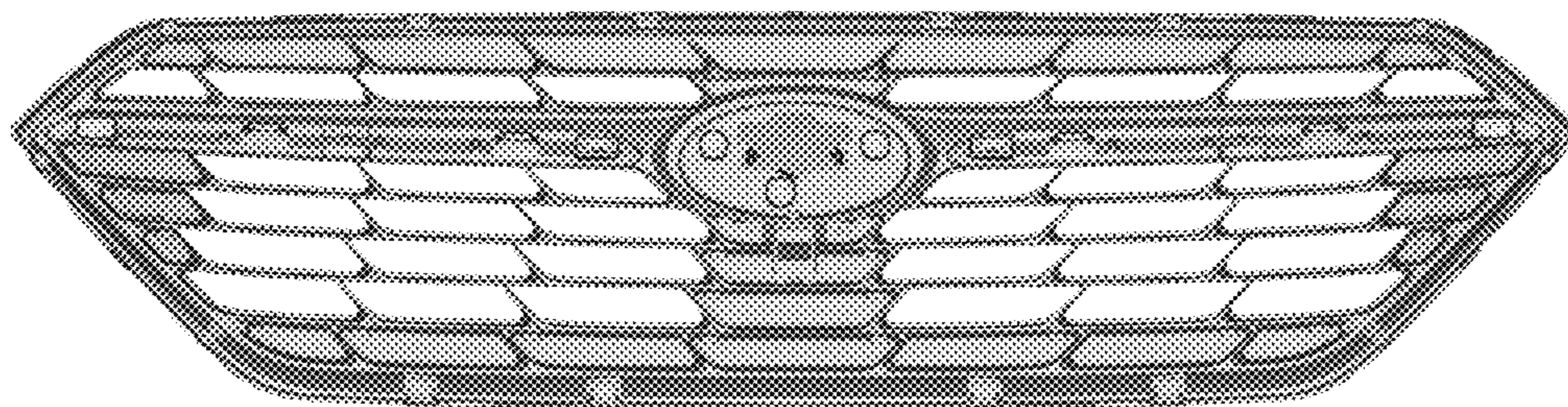

Fig. 5

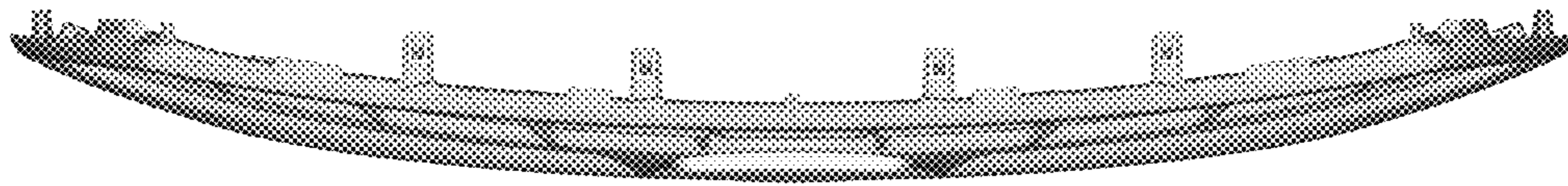

Fig. 6



Fig. 7



Fig. 8



Fig. 9

