



US00D928639S

(12) **United States Design Patent** (10) **Patent No.:** **US D928,639 S**
Ahn et al. (45) **Date of Patent:** **** Aug. 24, 2021**

(54) **REAR SENSOR HOUSING**

(71) Applicant: **Waymo LLC**, Mountain View, CA (US)

(72) Inventors: **YooJung Ahn**, Mountain View, CA (US); **Jared S. Gross**, Belmont, CA (US); **Thomas Southworth**, Royal Oak, MI (US); **Chun Chen**, Cupertino, CA (US)

(73) Assignee: **Waymo LLC**, Mountain View, CA (US)

(**) Term: **15 Years**

(21) Appl. No.: **29/688,905**

(22) Filed: **Apr. 25, 2019**

(51) **LOC (13) Cl.** **10-04**

(52) **U.S. Cl.**
USPC **D10/70; D12/190; D12/197**

(58) **Field of Classification Search**
USPC **D10/70; D12/190, 197**
(Continued)

(56) **References Cited**

U.S. PATENT DOCUMENTS

D328,436 S 8/1992 Fuerst et al.
5,945,907 A 8/1999 Yaron et al.
(Continued)

FOREIGN PATENT DOCUMENTS

KR 101998298 B1 7/2019
WO 2018138584 A1 8/2018

Primary Examiner — Antoine Duval Davis

(74) *Attorney, Agent, or Firm* — Banner & Witcoff, Ltd.

(57) **CLAIM**

The ornamental design for a rear sensor housing, as shown and described.

DESCRIPTION

The present application is related to U.S. Design patent application Ser. No. 29/688,903, entitled Front Sensor Housing, filed concurrently herewith, the entire disclosure of which is incorporated by reference herein.

FIG. 1 is a front perspective view of a rear sensor housing according to a first embodiment of our design; FIG. 2 is a front elevation view thereof; FIG. 3 is a back elevation view thereof; FIG. 4 is a right side elevation view thereof; FIG. 5 is a left side elevation view thereof; FIG. 6 is a top plan view thereof; FIG. 7 is a bottom plan view thereof; FIG. 8 is a front perspective view of a rear sensor housing according to a second embodiment of our design; FIG. 9 is a front elevation view thereof; FIG. 10 is a back elevation view thereof; FIG. 11 is a right side elevation view thereof; FIG. 12 is a left side elevation view thereof; FIG. 13 is a top plan view thereof; FIG. 14 is a bottom plan view thereof; FIG. 15 is a front perspective view of a rear sensor housing according to a third embodiment of our design; FIG. 16 is a front elevation view thereof; FIG. 17 is a back elevation view thereof; FIG. 18 is a right side elevation view thereof; FIG. 19 is a left side elevation view thereof; FIG. 20 is a top plan view thereof; FIG. 21 is a bottom plan view thereof; and, FIG. 22 is a front perspective view of the rear sensor housing of the first embodiment positioned on an exemplary vehicle. The broken lines in the figures illustrate portions of the rear sensor housing that form no part of the claimed design. The broken lines shown in FIG. 22 illustrate an exemplary vehicle that forms no part of the claimed design. The specific placement of the rear sensor housing in FIG. 22 on the exemplary vehicle is for illustrative purposes only and does not limit placement of the rear sensor housing to a specific location on a vehicle or other object.

1 Claim, 13 Drawing Sheets

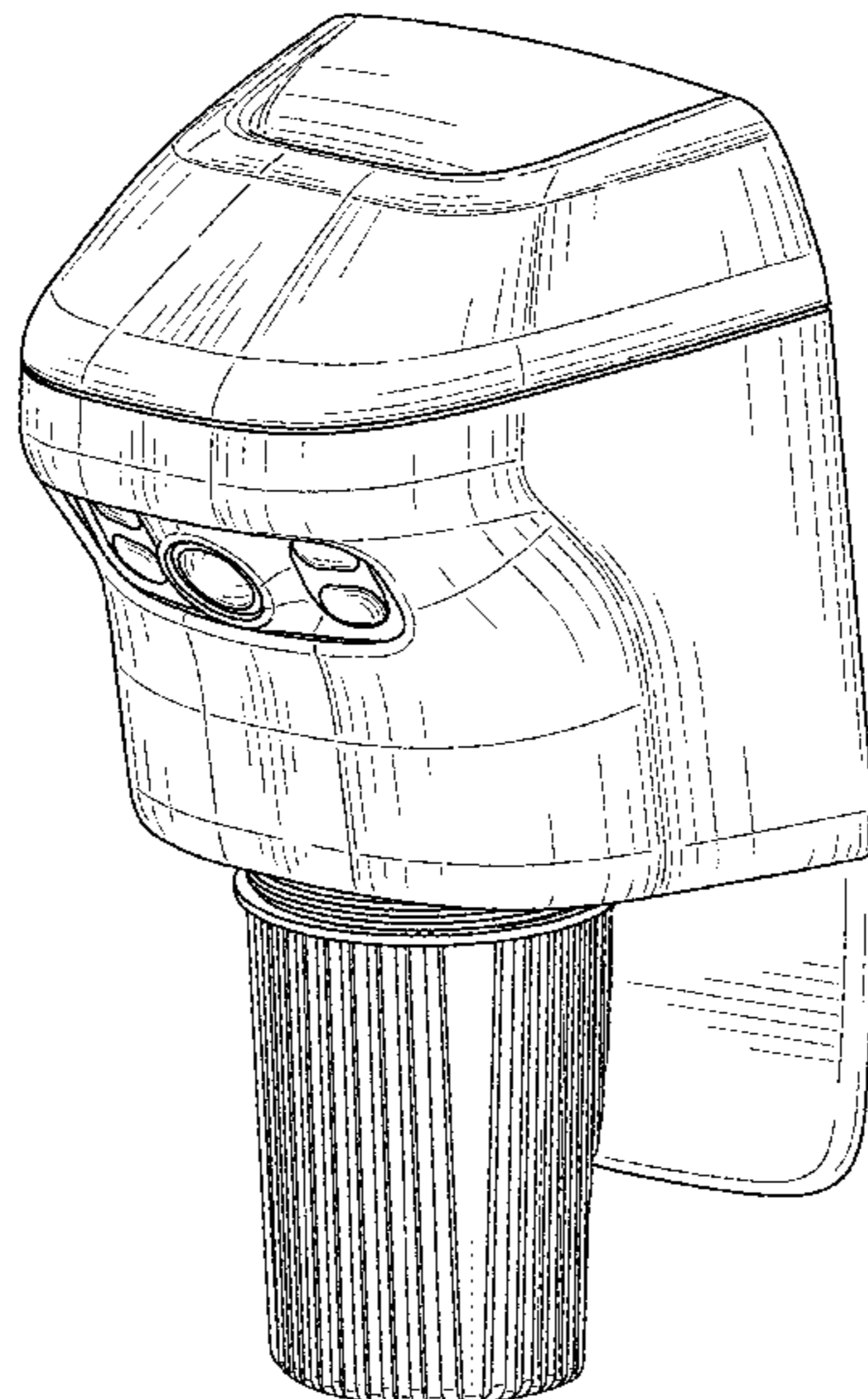

(58) **Field of Classification Search**

CPC .. B60Q 1/0017; B60Q 1/0023; B60Q 1/0029;
 B60Q 1/0035; B60Q 1/0041; B60Q 1/26;
 B60Q 1/2603; B60Q 1/2607; B60Q
 1/2611; B60Q 9/002; B60Q 9/003; B60Q
 9/004; B60Q 9/006; B60Q 9/007; B60Q
 9/008; B60R 1/10; B60R 1/12; B60R
 2001/1284; B60R 1/002; B60R 2300/105;
 B60R 2300/106; B60R 2300/802; B60R
 2300/8093; H04N 5/2254; H04N 5/2252;
 H04N 5/2256; H04N 5/33; G02B 3/0037

See application file for complete search history.

(56) **References Cited**

U.S. PATENT DOCUMENTS

D478,518 S	8/2003	Porter
D525,888 S	8/2006	Porter
9,725,060 B1	8/2017	Daniel et al.
9,862,311 B2	1/2018	Kiriyama et al.
D825,357 S	8/2018	Ahn et al.

D826,073 S	8/2018	Alkelai et al.	
D834,971 S	12/2018	Ahn et al.	
D835,028 S	12/2018	Ahn et al.	
D850,303 S	6/2019	Wang et al.	
D850,946 S	6/2019	Zhevelev et al.	
D860,013 S	9/2019	Ahn et al.	
10,444,752 B2	10/2019	Kim et al.	
D874,957 S *	2/2020	Ahn	D10/70
2013/0242586 A1 *	9/2013	Huizen	B60R 1/12 362/494
2016/0011594 A1	1/2016	Chung et al.	
2017/0151933 A1	6/2017	Doorley et al.	
2017/0293016 A1	10/2017	McCloskey et al.	
2017/0297488 A1	10/2017	Wang et al.	
2017/0300060 A1	10/2017	Crawley	
2017/0343654 A1	11/2017	Valois et al.	
2018/0011173 A1	1/2018	Newman	
2018/0015886 A1	1/2018	Frank et al.	
2018/0017680 A1	1/2018	Pennecot et al.	
2018/0037268 A1	2/2018	Moore et al.	
2018/0086280 A1	3/2018	Nguyen	
2020/0195816 A1	6/2020	Stein et al.	

* cited by examiner

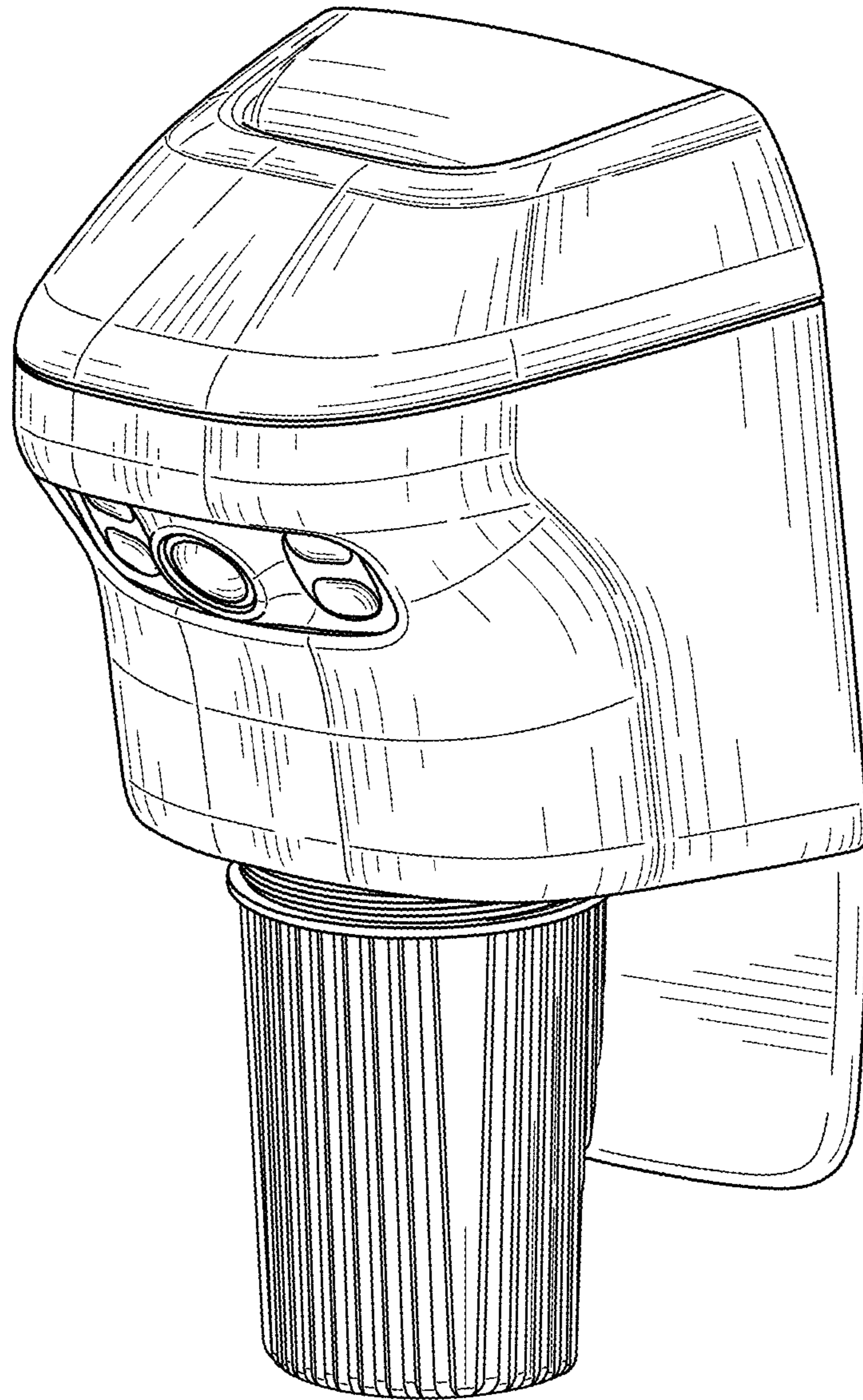

FIG. 1

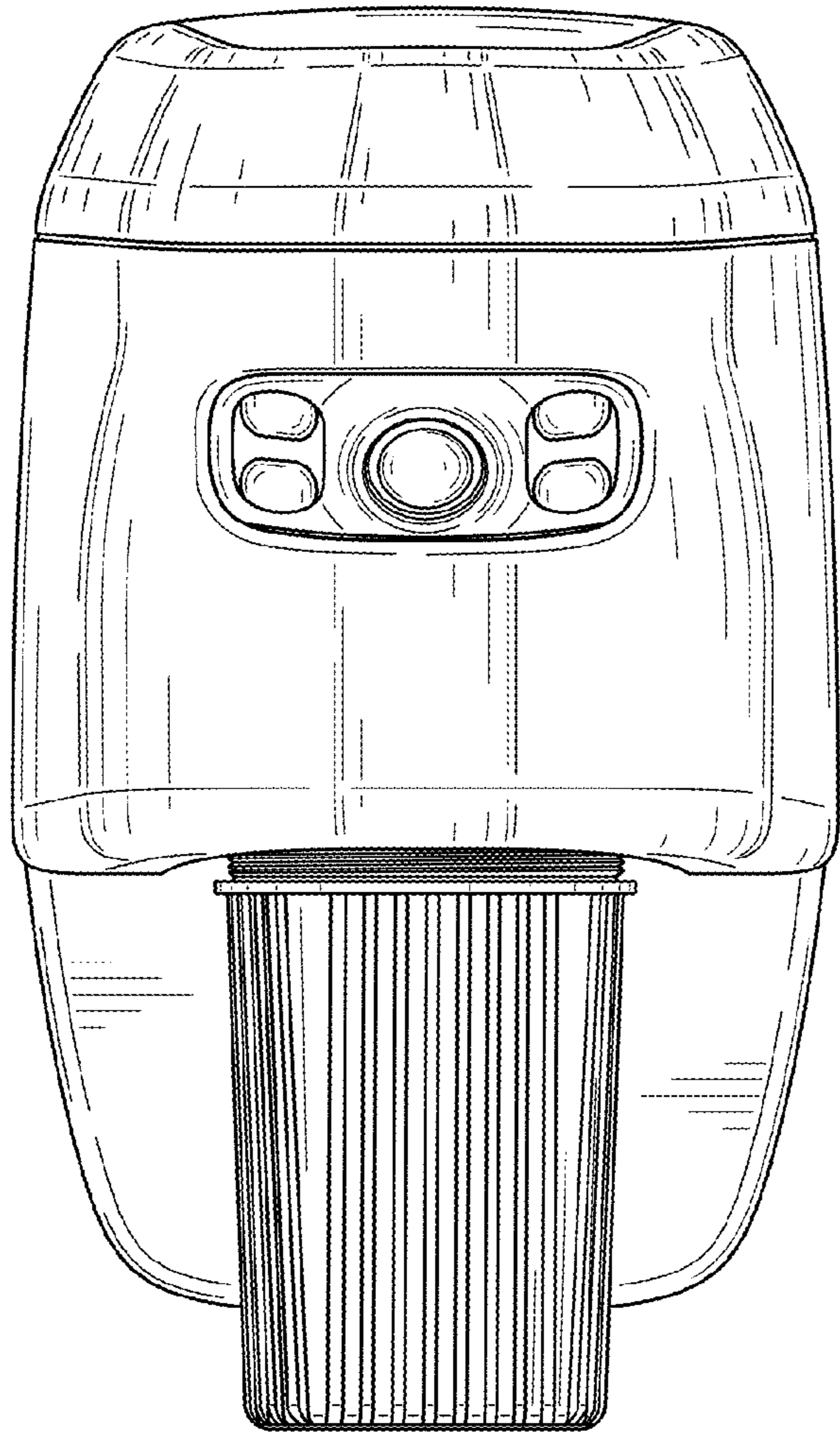

FIG. 2

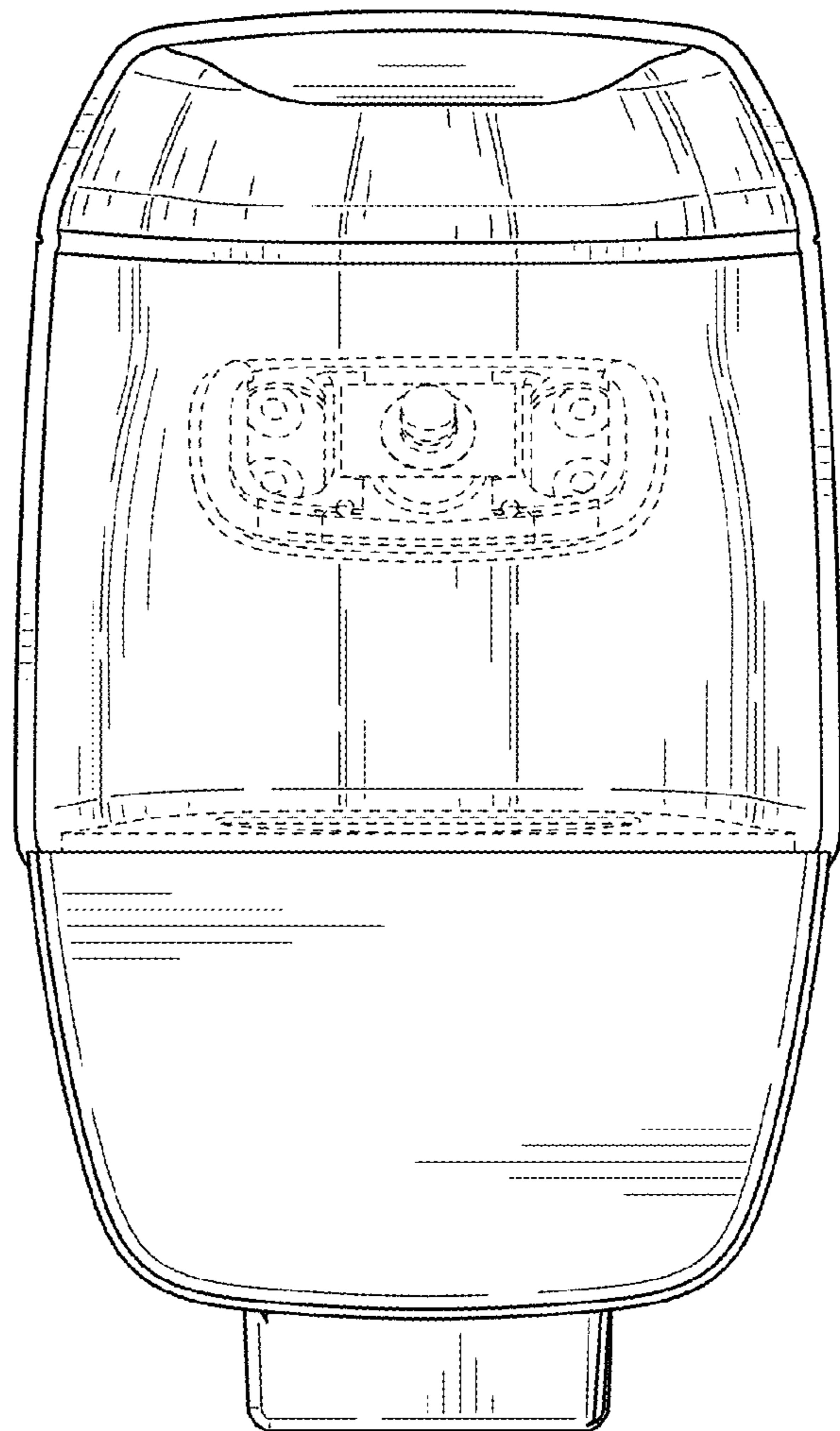

FIG. 3

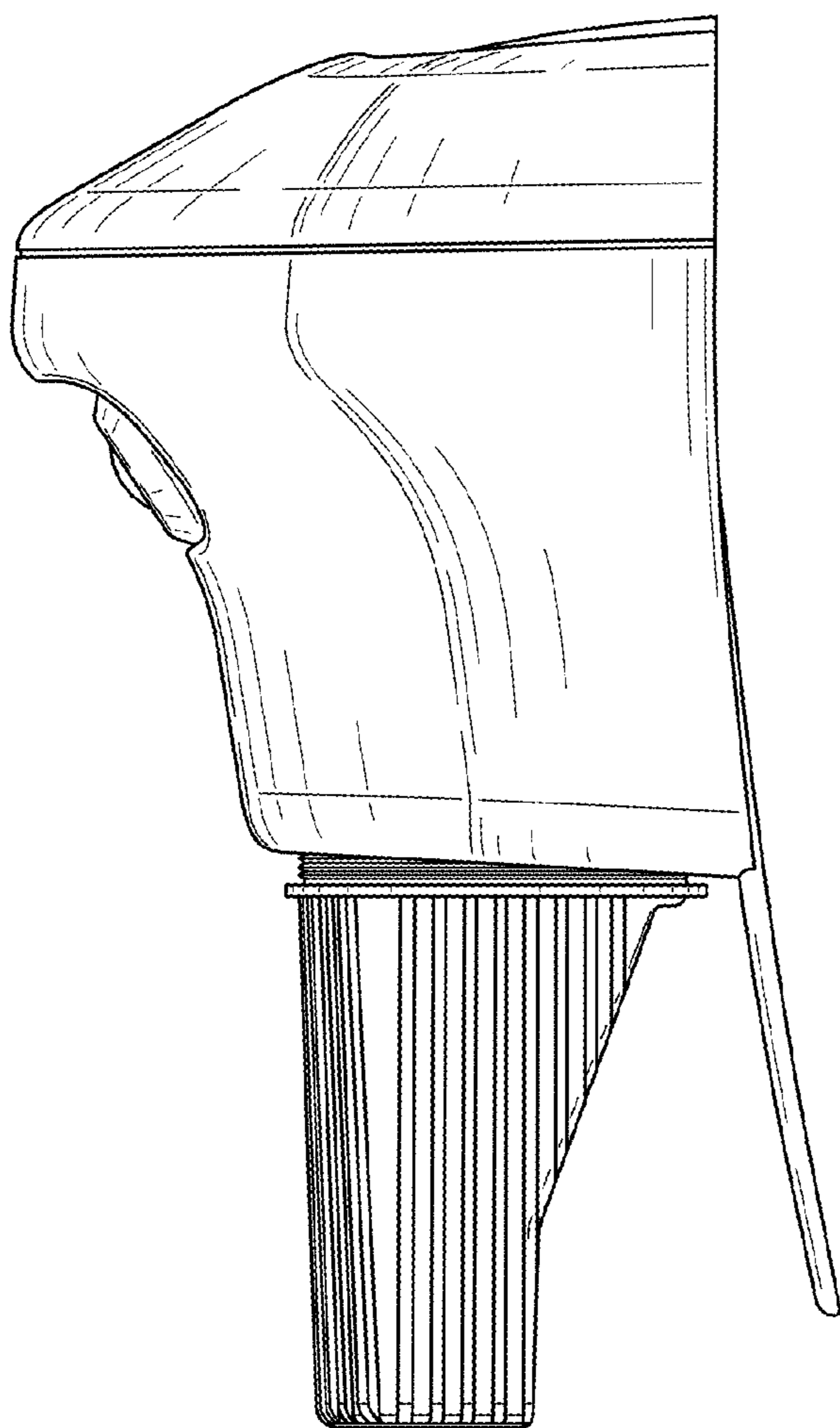

FIG. 4

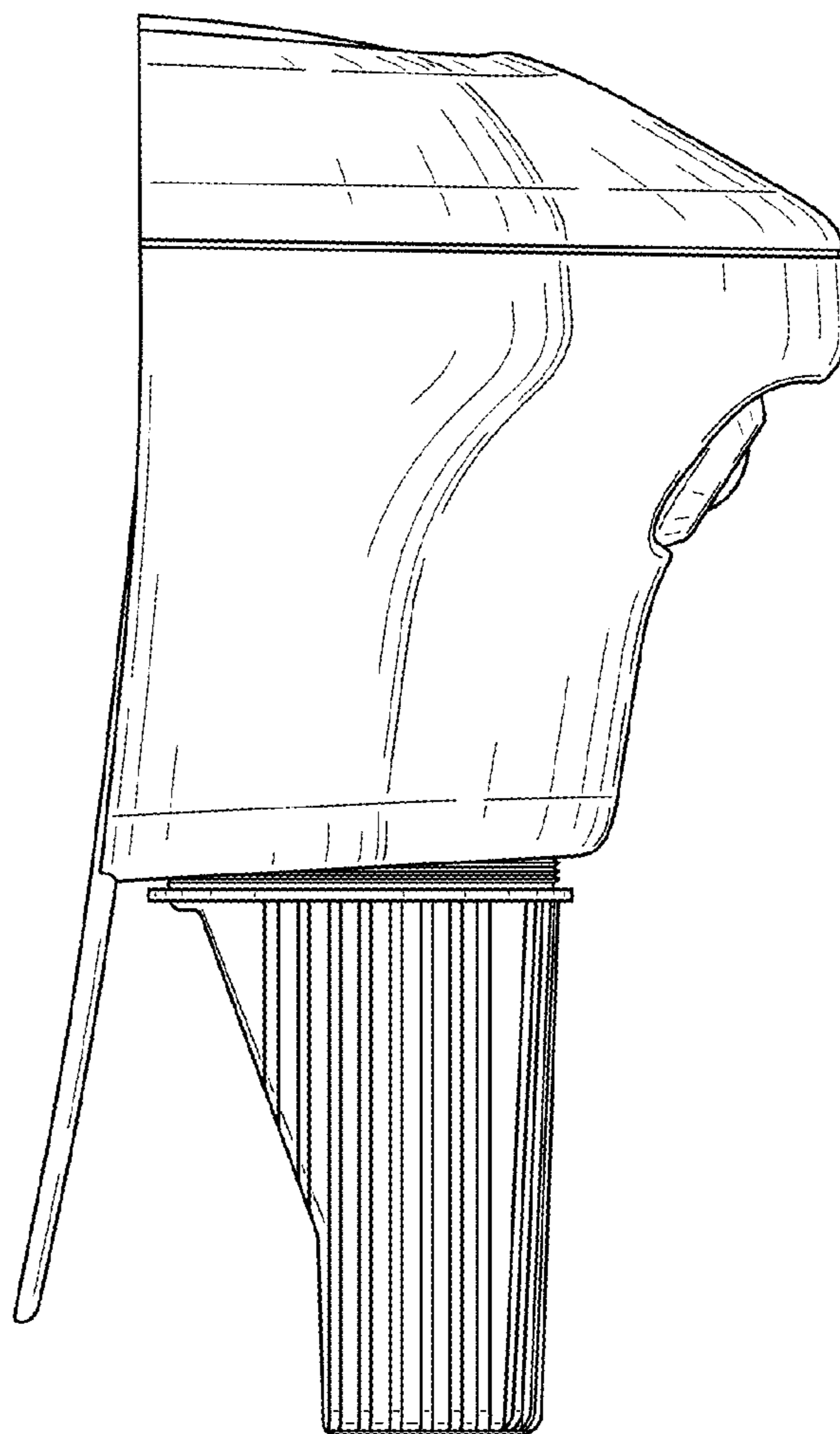

FIG. 5

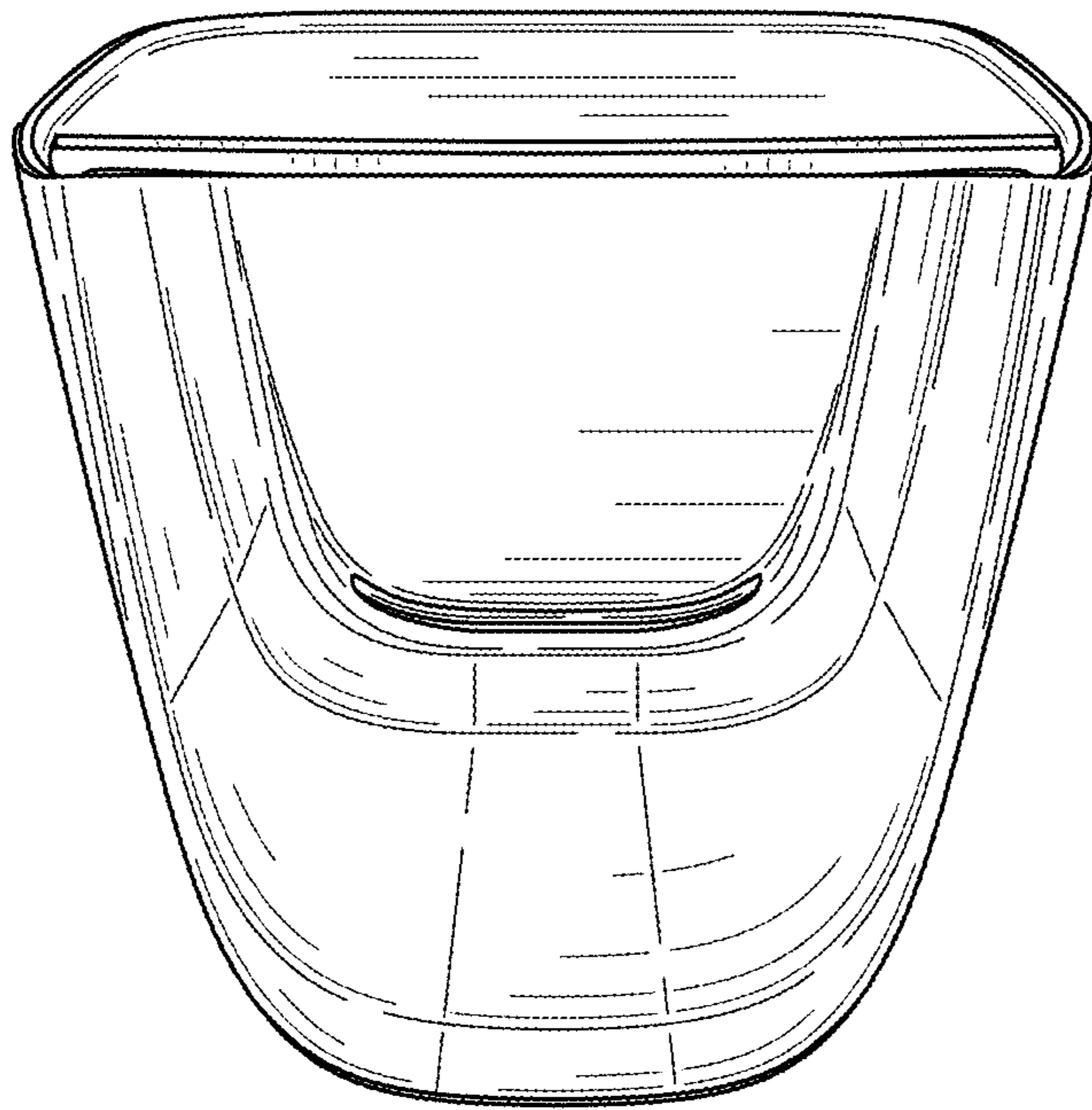

FIG. 6

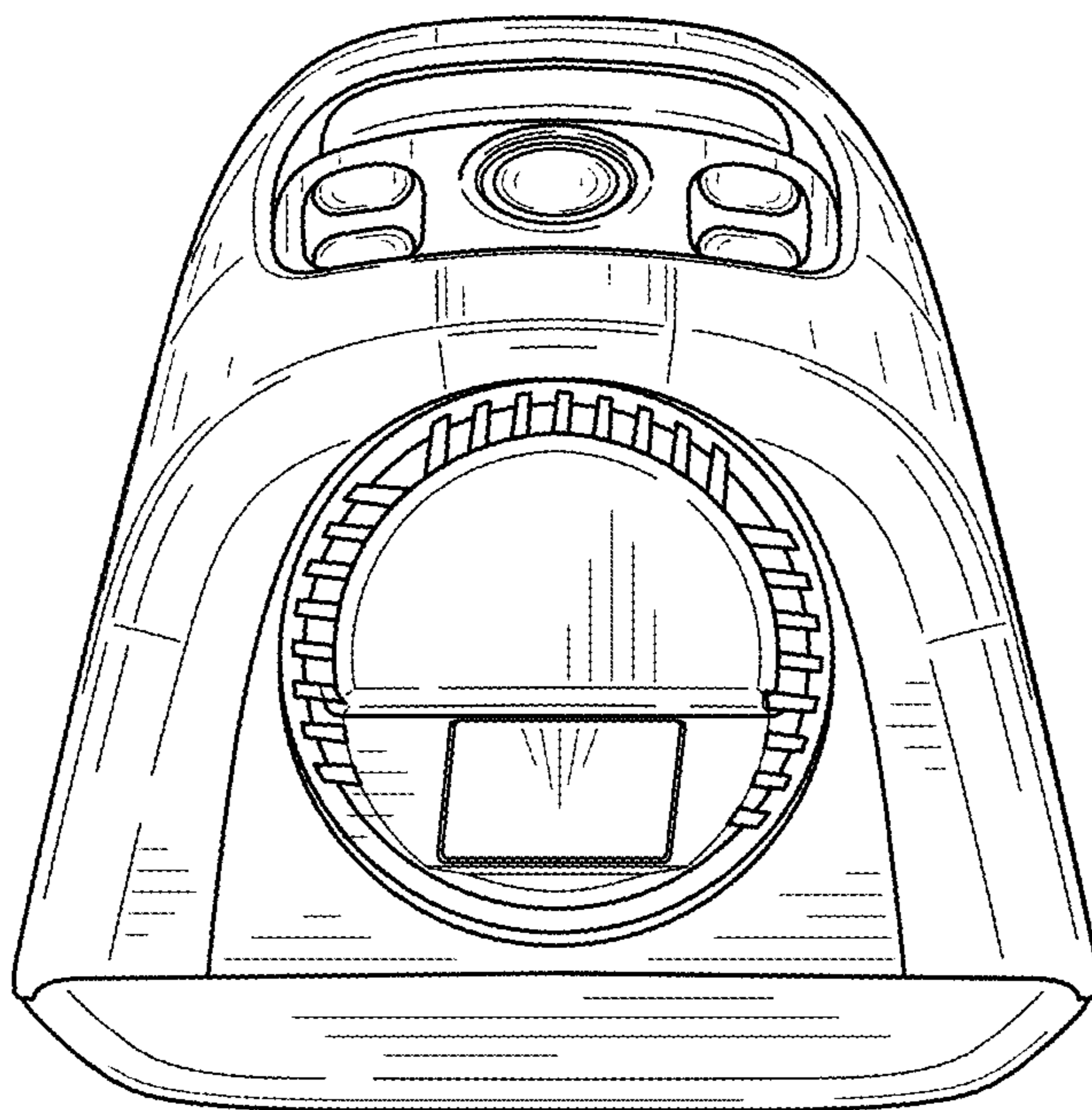

FIG. 7

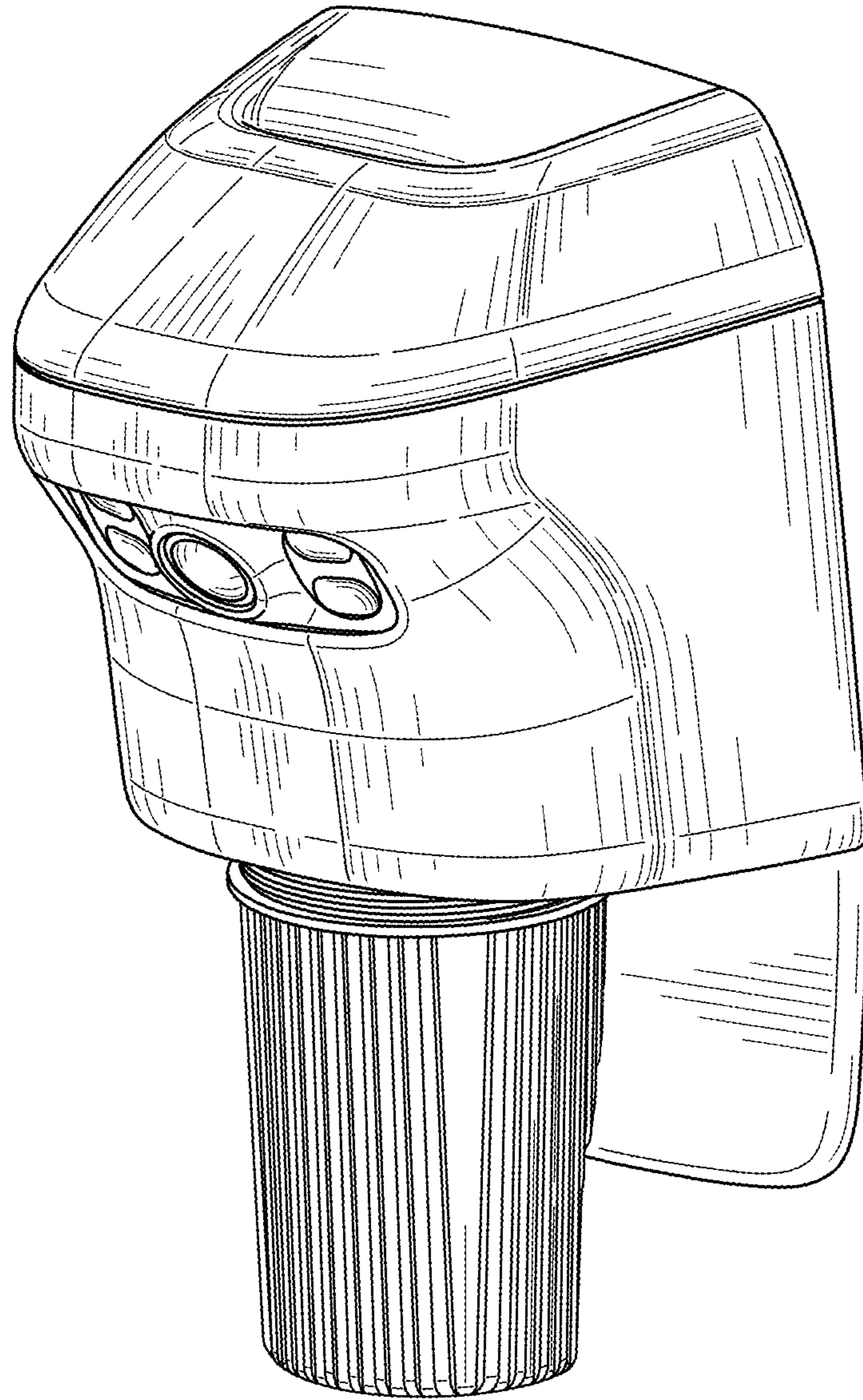

FIG. 8

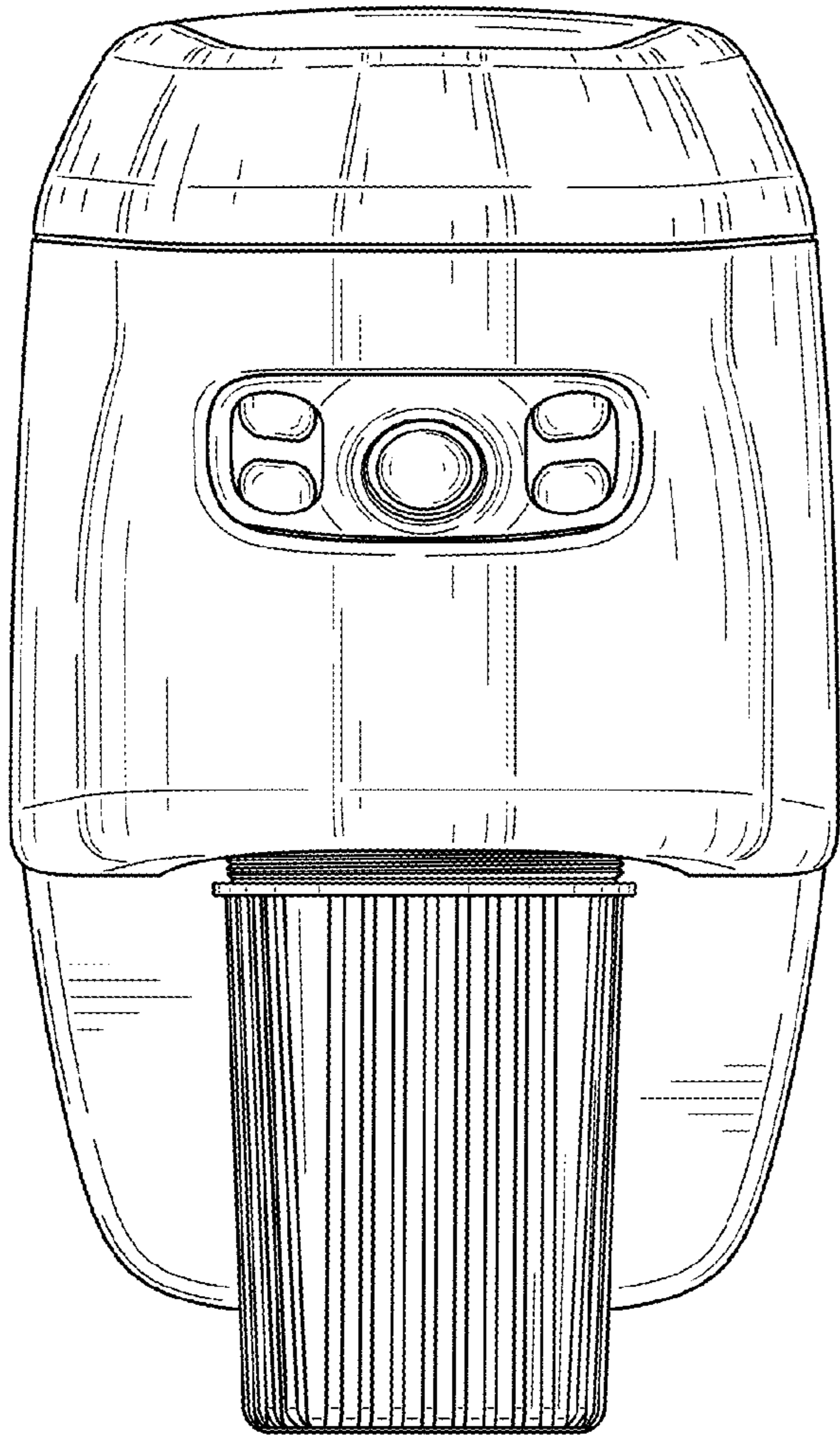

FIG. 9

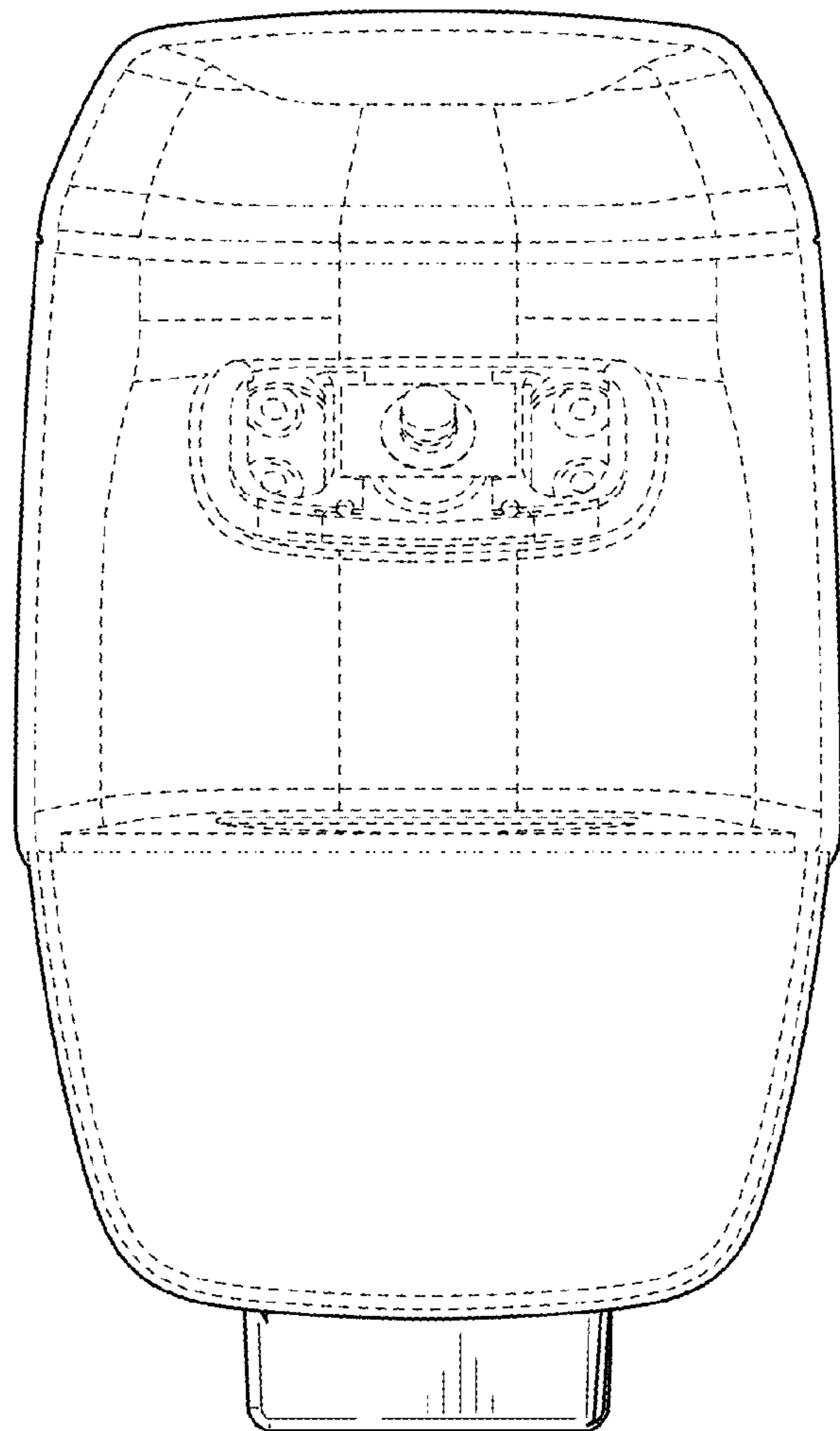

FIG. 10

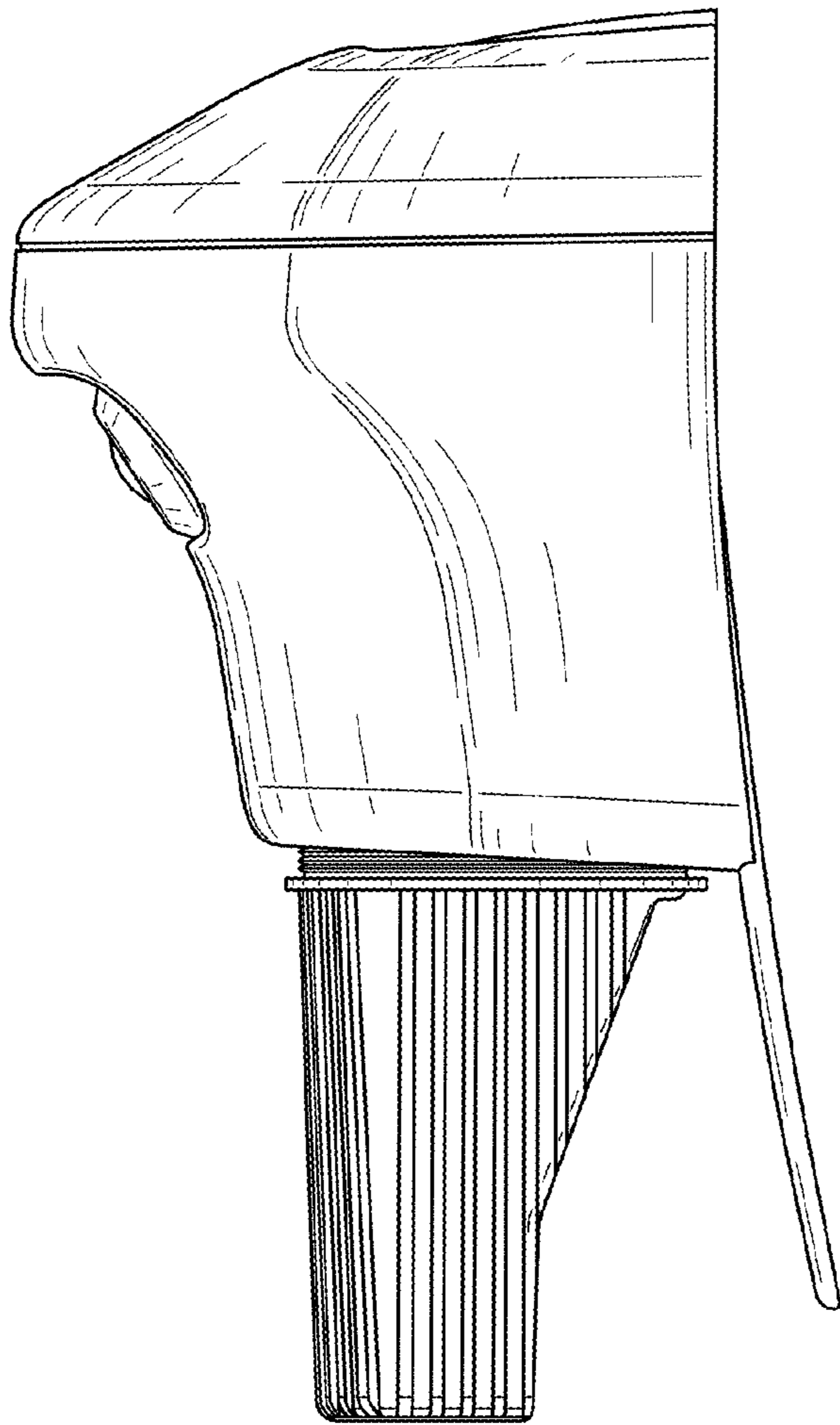

FIG. 11

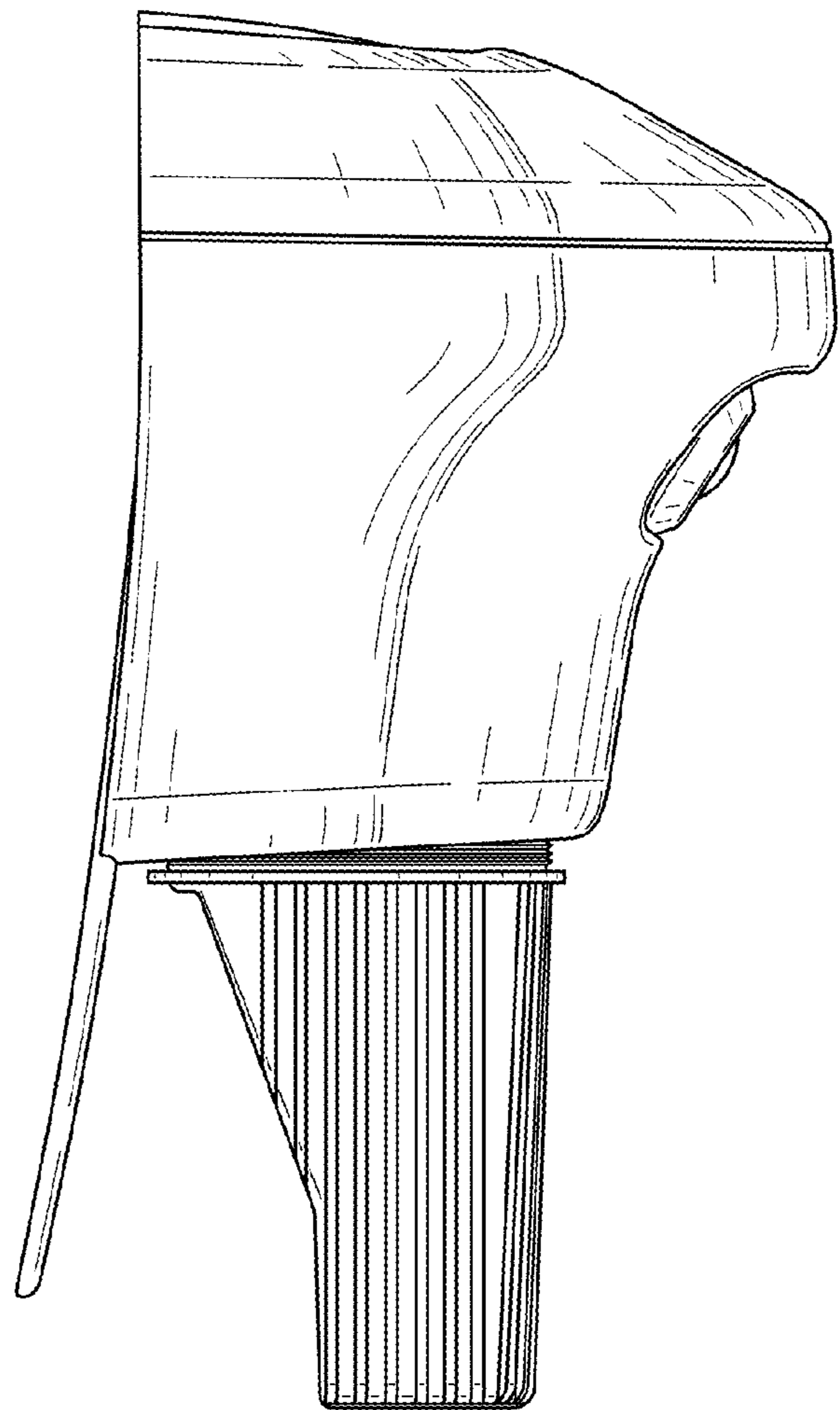

FIG. 12

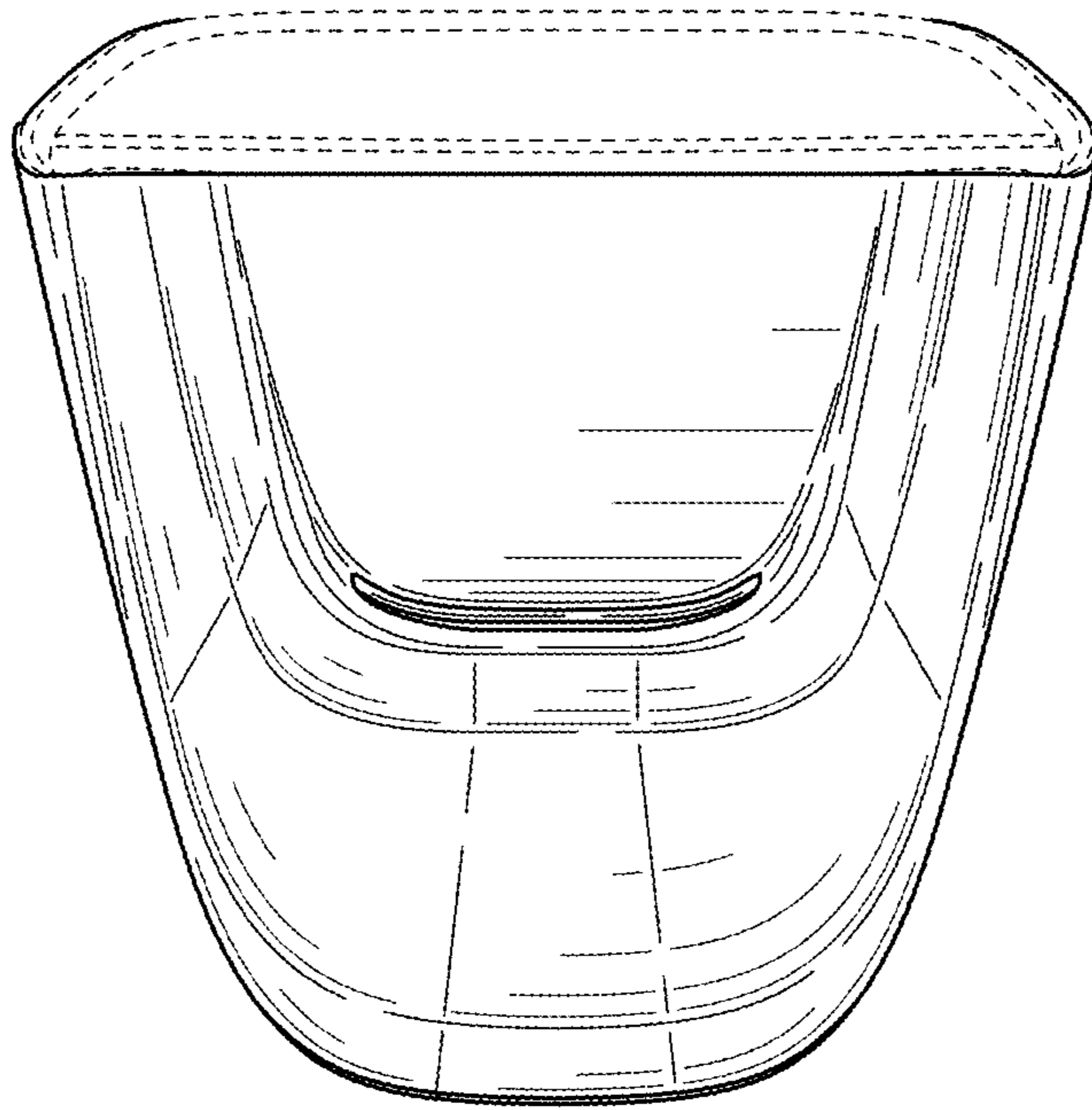

FIG. 13

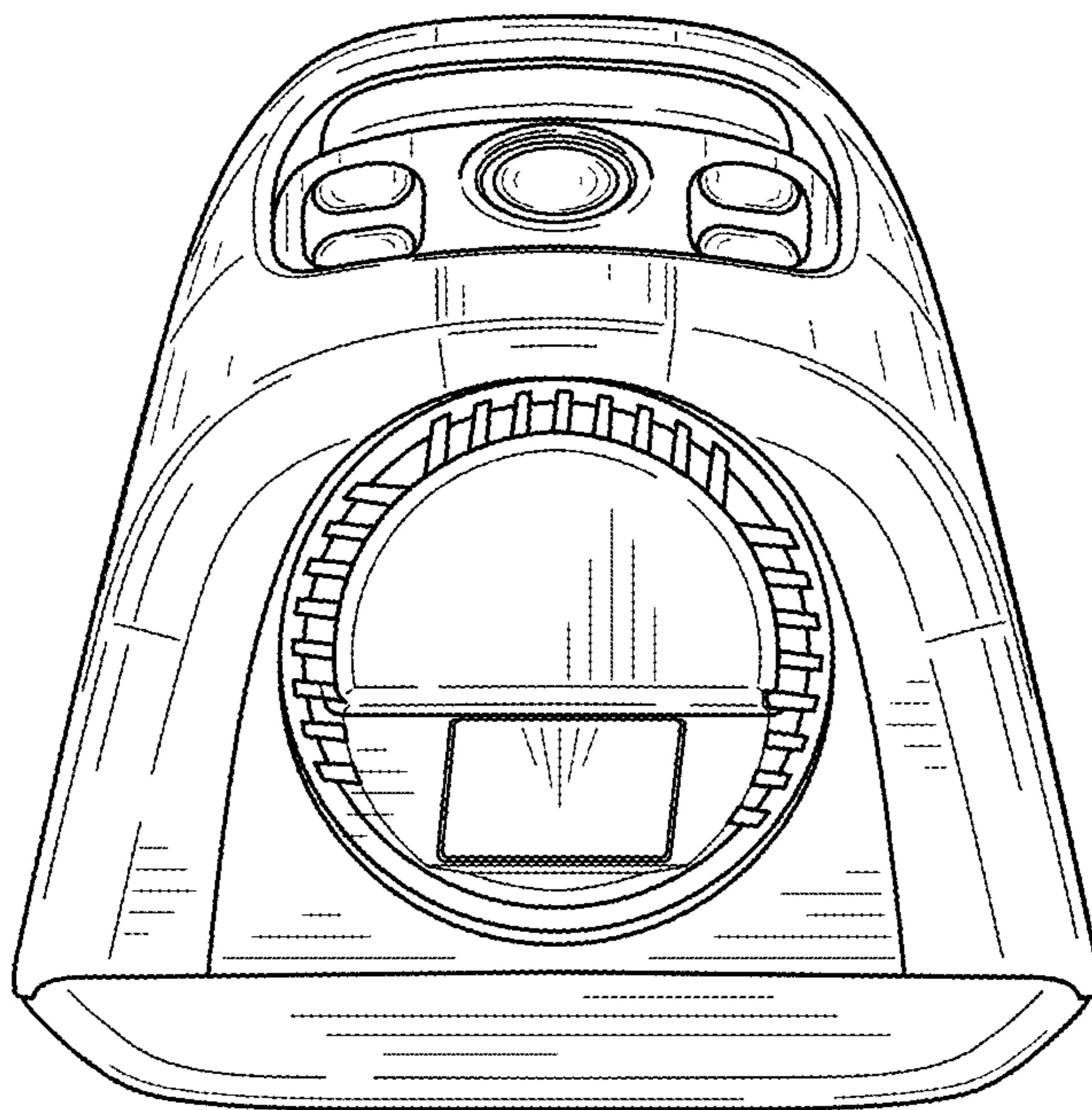

FIG. 14

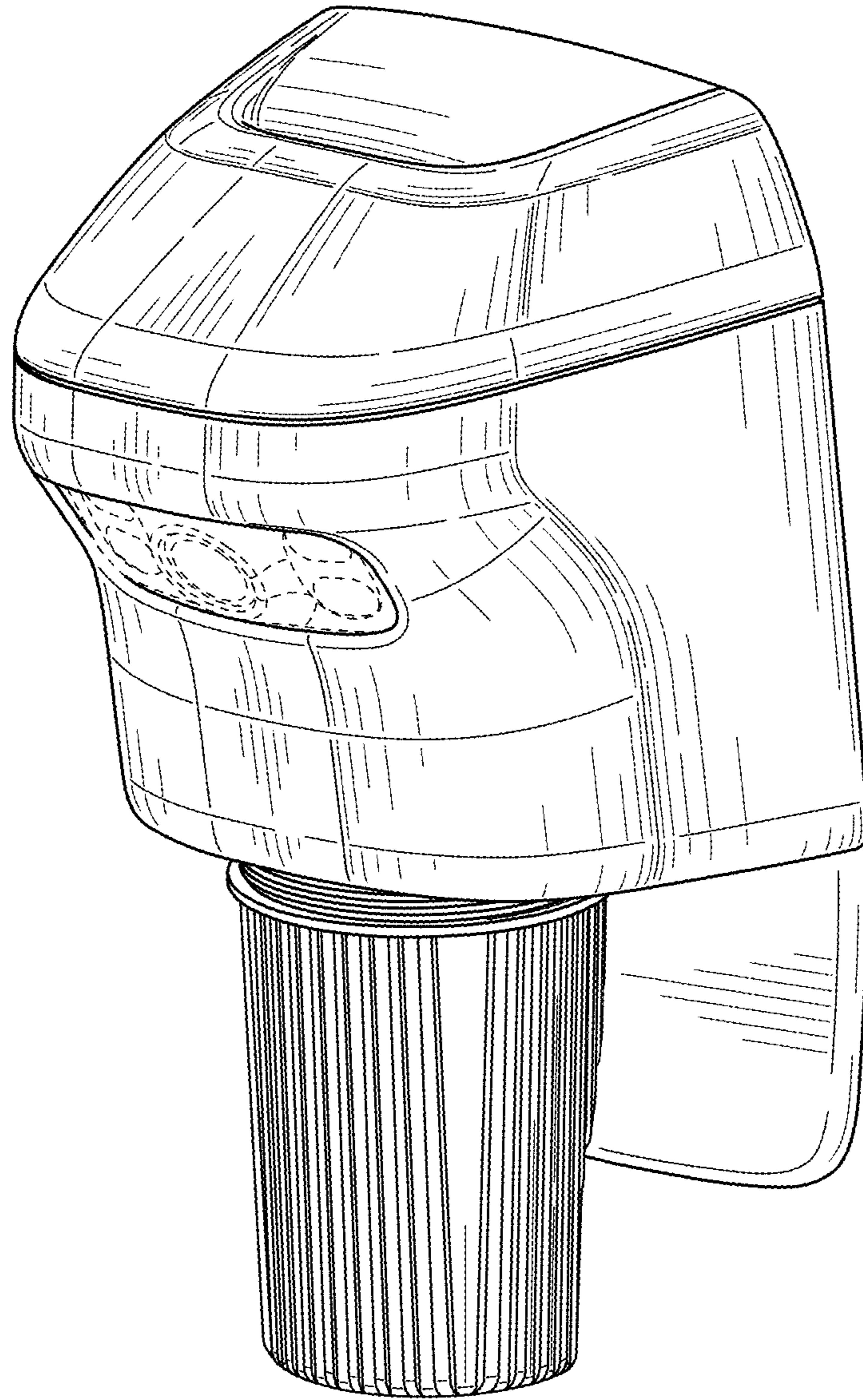

FIG. 15

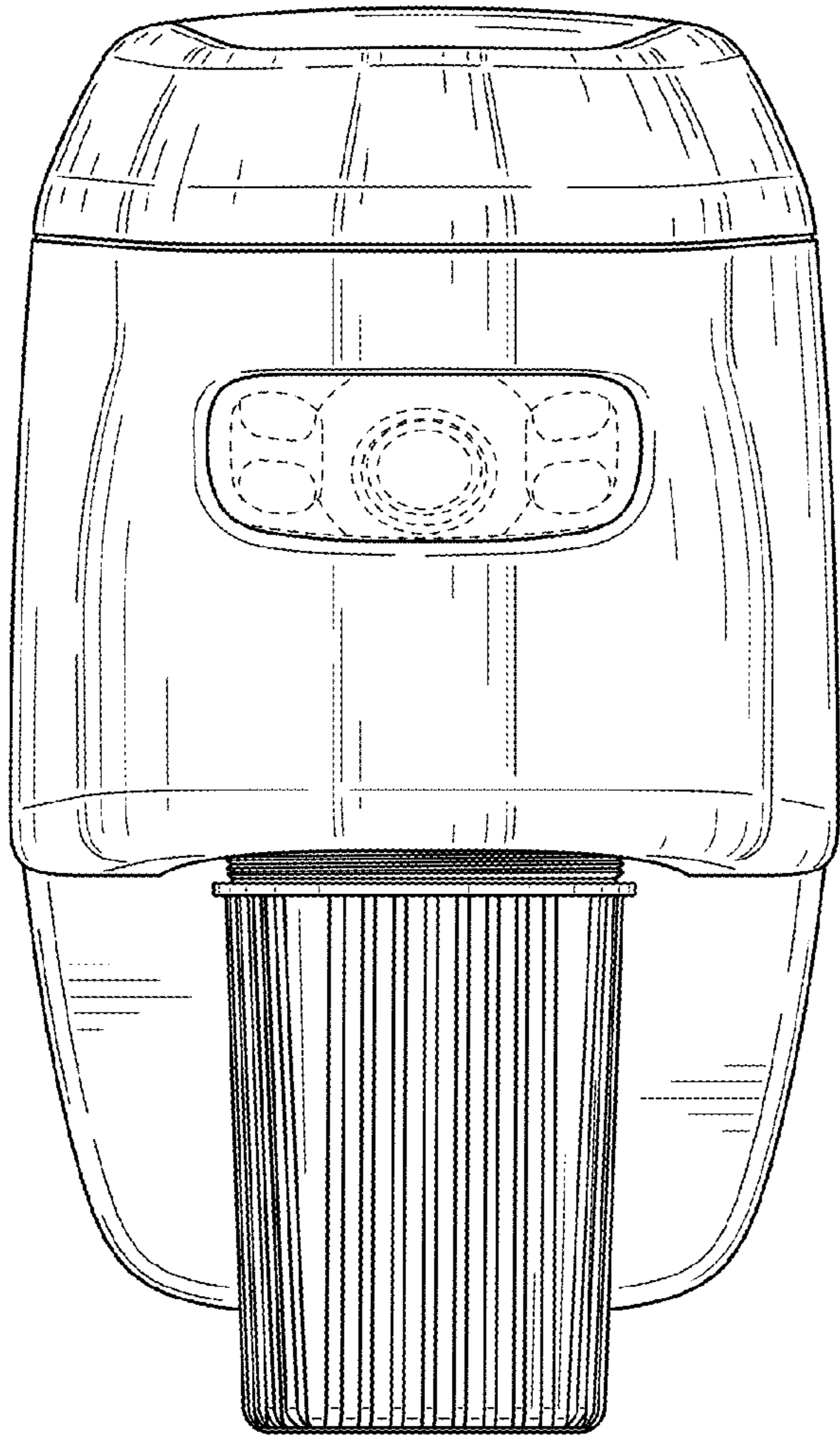

FIG. 16

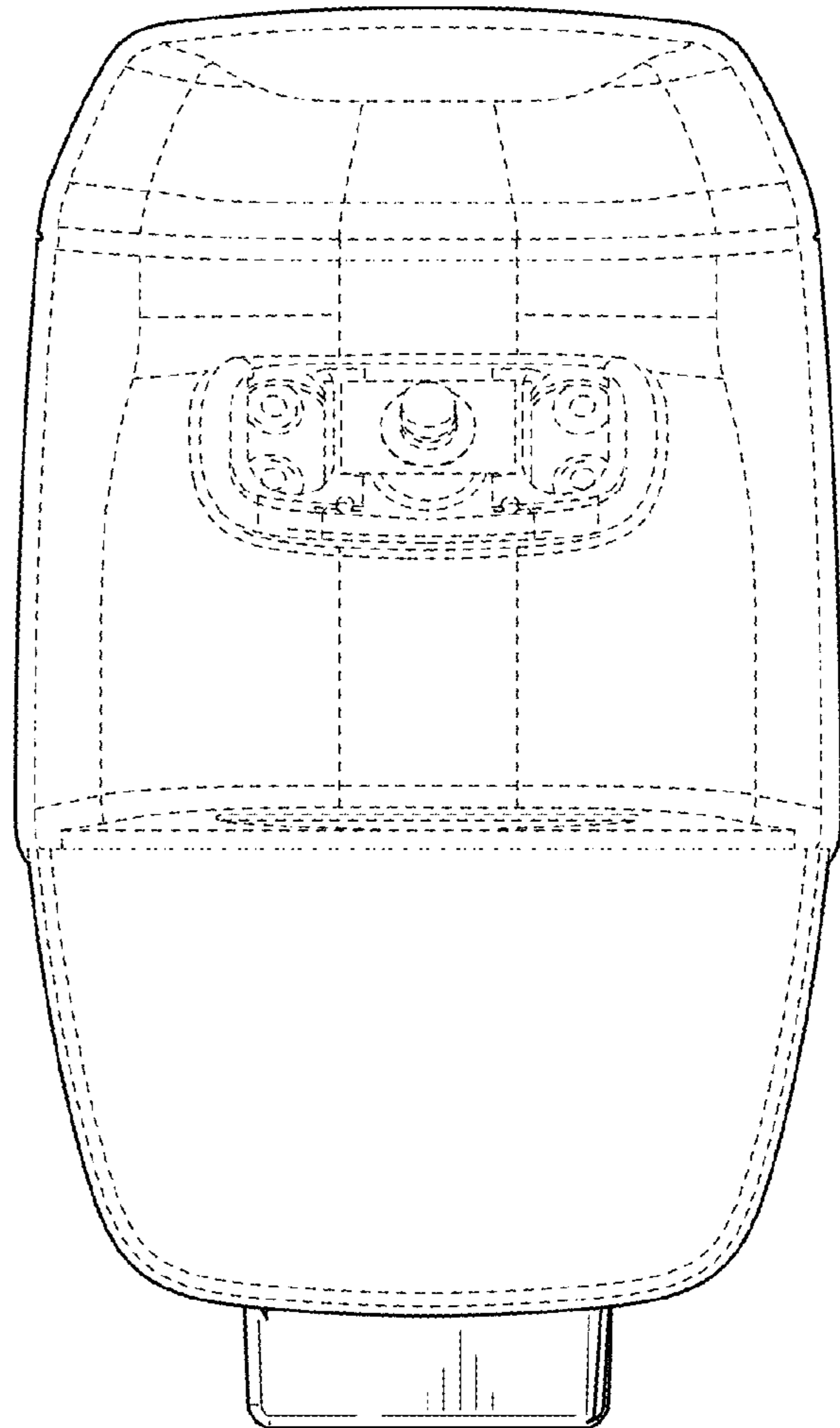

FIG. 17

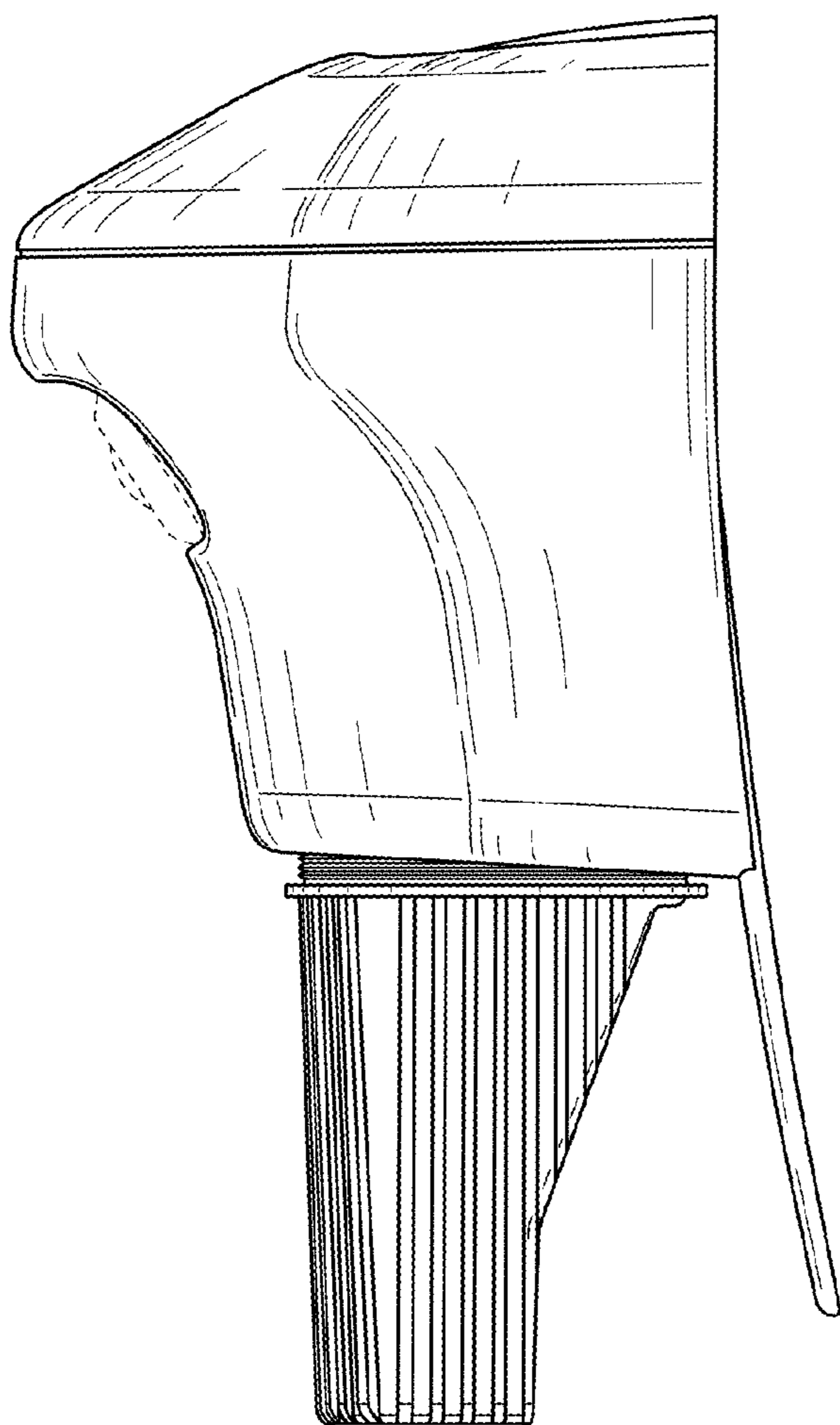

FIG. 18

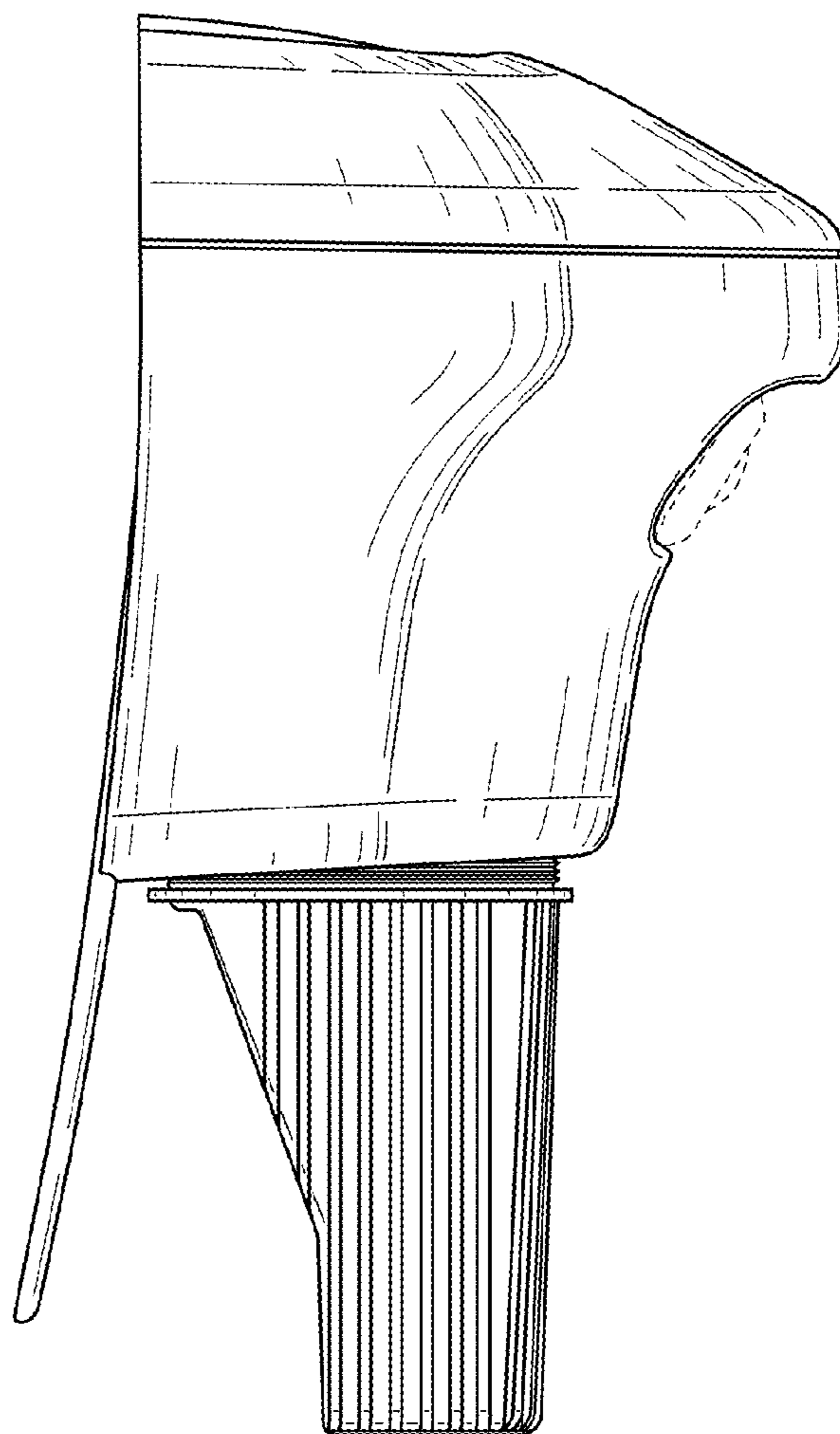

FIG. 19

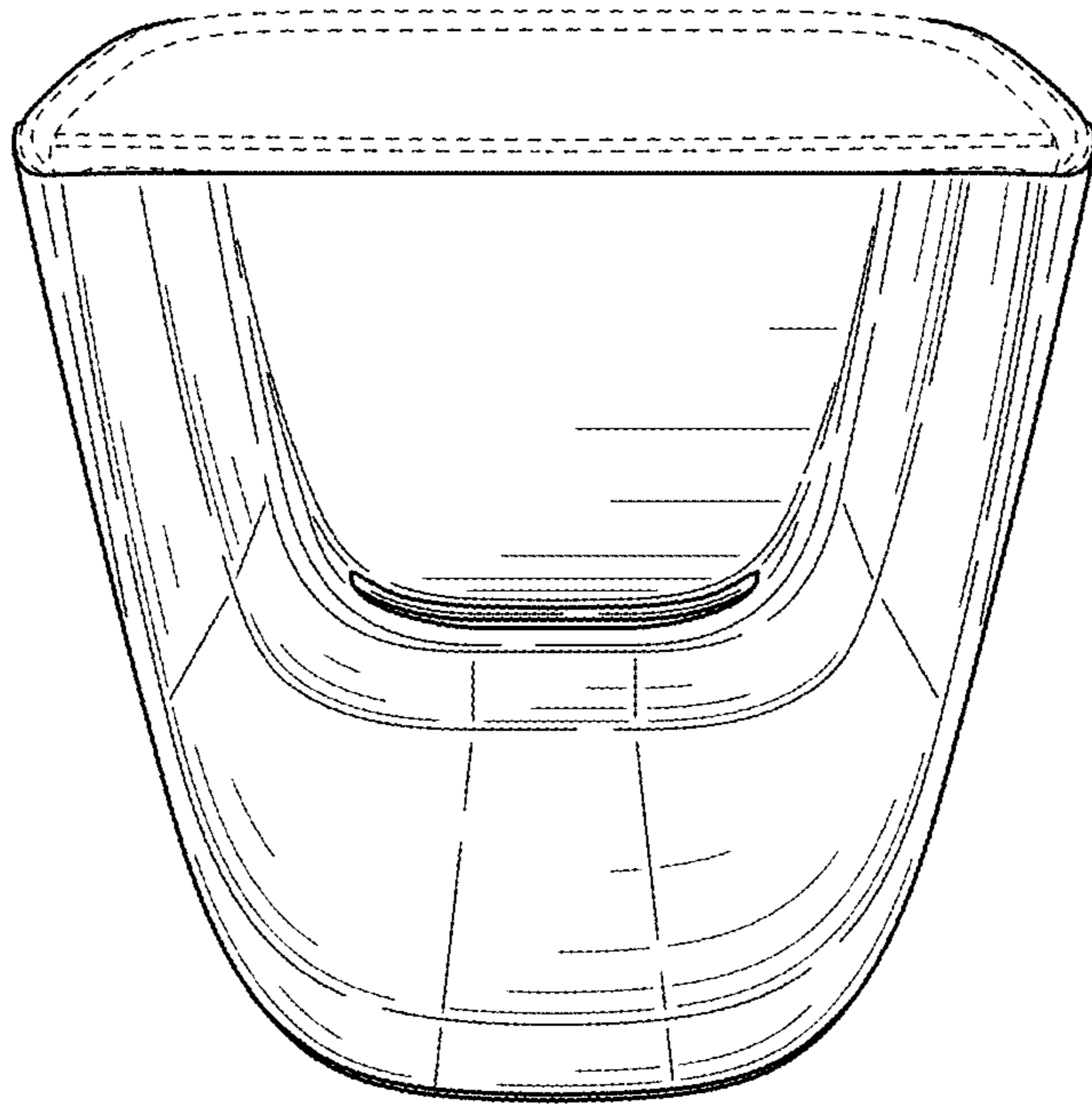

FIG. 20

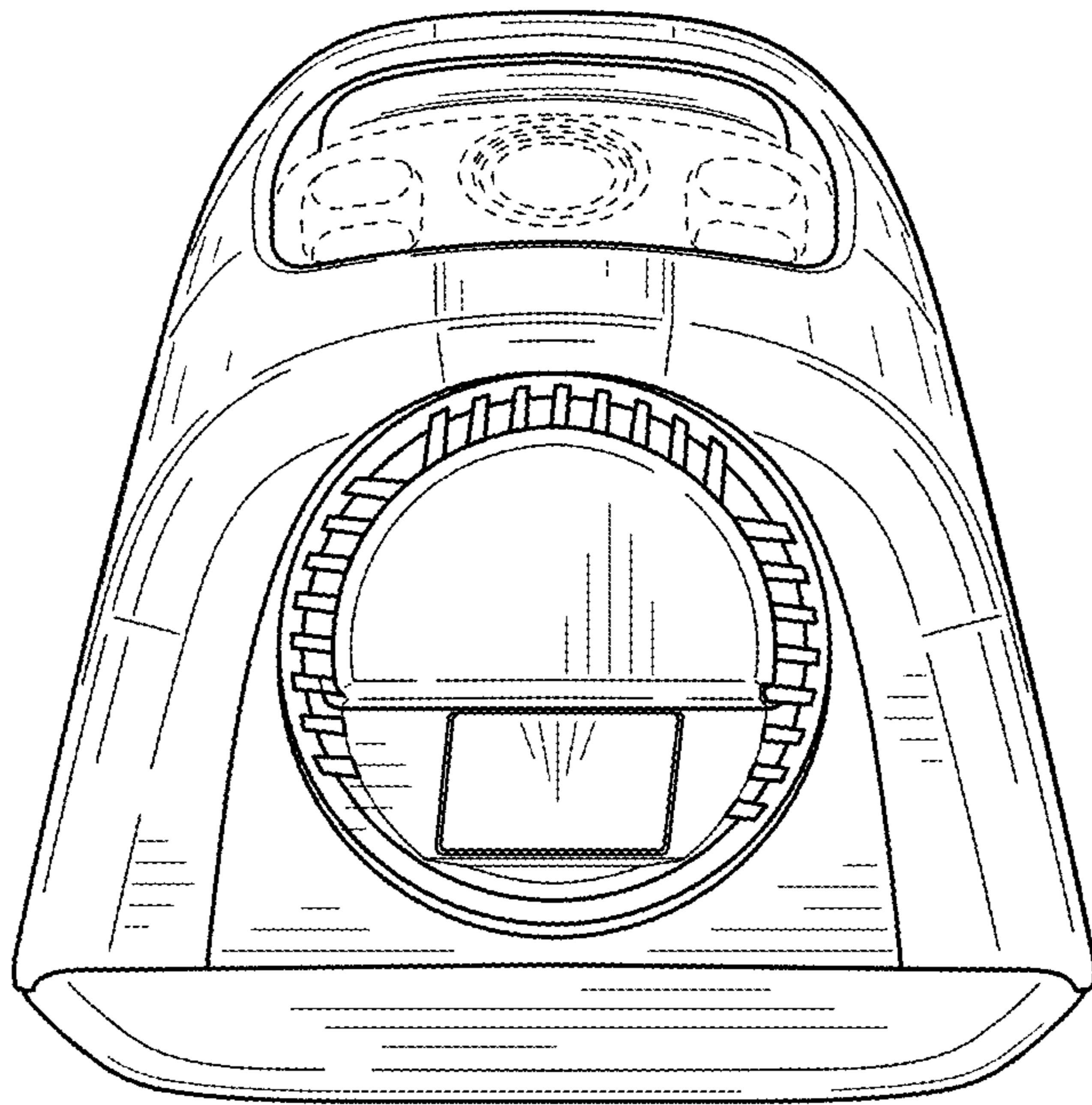

FIG. 21

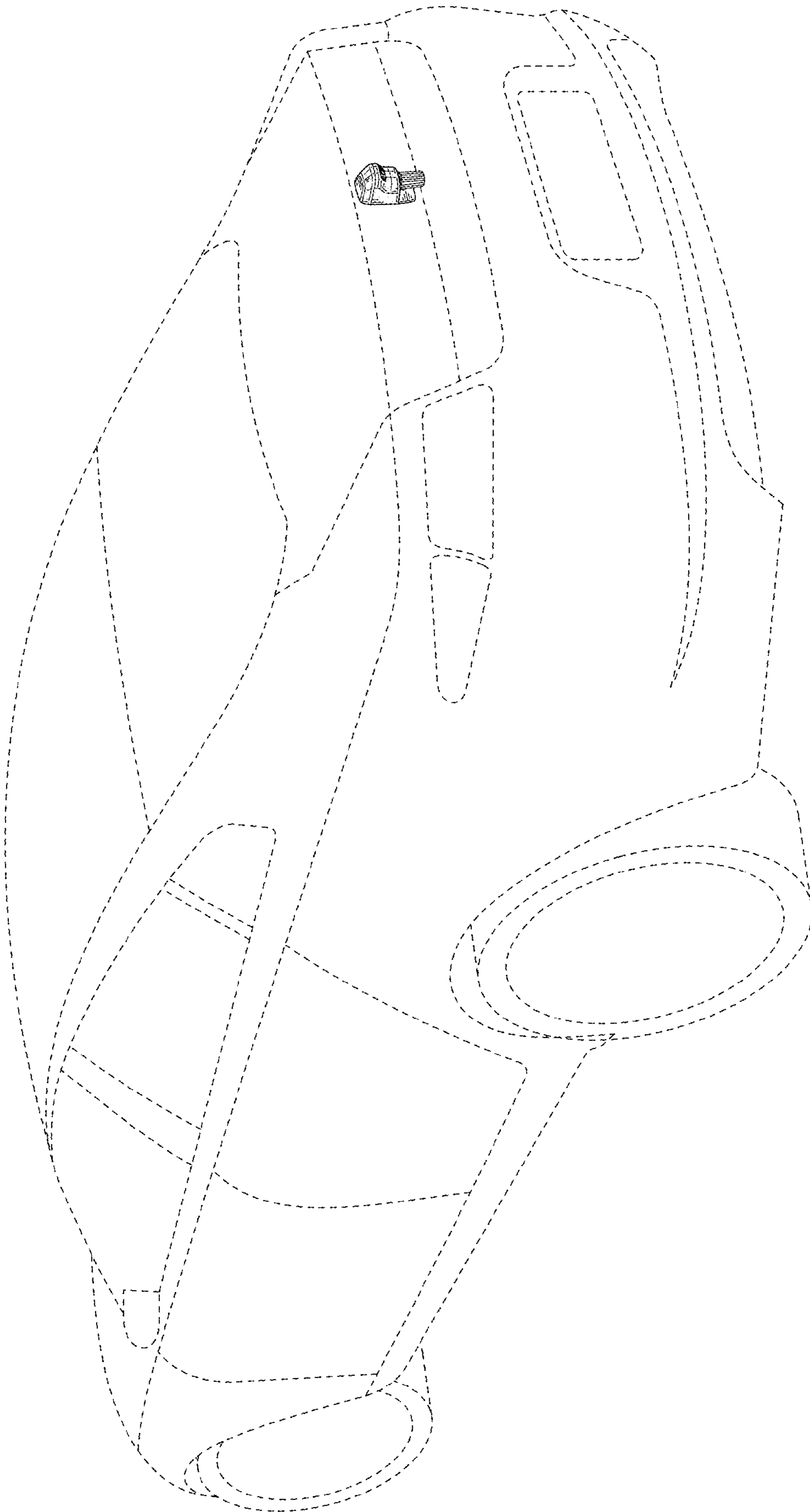

FIG. 22