



US00D928065S

(12) **United States Design Patent**
McGugan et al.

(10) **Patent No.:** **US D928,065 S**

(45) **Date of Patent:** **** Aug. 17, 2021**

(54) **WHEEL CHOCK**

(71) Applicants: **Austin Hugh McGugan**, Greensboro, NC (US); **Bruce Andrew Angel**, Stokesdale, NC (US); **Anthony Dwayne Moore**, Summerfield, NC (US)

(72) Inventors: **Austin Hugh McGugan**, Greensboro, NC (US); **Bruce Andrew Angel**, Stokesdale, NC (US); **Anthony Dwayne Moore**, Summerfield, NC (US)

(73) Assignee: **Camco Manufacturing, Inc.**, Greensboro, NC (US)

(**) Term: **15 Years**

(21) Appl. No.: **29/649,227**

(22) Filed: **May 29, 2018**

(51) **LOC (13) Cl.** **12-16**

(52) **U.S. Cl.**
USPC **D12/217**

(58) **Field of Classification Search**
USPC D12/217, 400, 223, 106; D34/31, 32, 38;
D25/102, 113; D8/354
See application file for complete search history.

(56) **References Cited**

U.S. PATENT DOCUMENTS

D236,612 S *	9/1975	Wetzel et al.	D12/217
D282,459 S *	2/1986	Sauber	D12/217
D493,408 S *	7/2004	Chrisco	D12/217
D500,979 S *	1/2005	Chrisco	D12/217
D502,139 S *	2/2005	Chrisco	D12/217
D503,139 S *	3/2005	Colak	D12/217
D531,568 S *	11/2006	Davidian	D12/217
D577,651 S *	9/2008	Shaw	D12/217

D594,398 S *	6/2009	Tai	D12/217
D601,479 S *	10/2009	Shaw	D12/217
D646,614 S *	10/2011	Brockington	D12/217
D656,881 S *	4/2012	Beranek	D12/217
D656,882 S *	4/2012	Beranek	D12/217
D662,026 S *	6/2012	Beranek	D12/217
D673,106 S *	12/2012	Rossmann	D12/217
D720,278 S *	12/2014	Pinkall	D12/217
D809,987 S *	2/2018	Angel	D12/217
D809,988 S *	2/2018	Angel	D12/217
D855,005 S *	7/2019	Delancey	D12/217
D860,107 S *	9/2019	Bilgin	D12/217
D868,635 S *	12/2019	Angel	D12/217
D918,522 S *	5/2021	Angel	D34/32
D918,523 S *	5/2021	Angel	D34/32
D918,776 S *	5/2021	Angel	D12/106

* cited by examiner

Primary Examiner — Stacia A Cadmus

(74) *Attorney, Agent, or Firm* — Tuggle Duggins P.A.;
Blake P. Hurt

(57) **CLAIM**

The ornamental design for a wheel chock, as shown and described.

DESCRIPTION

FIG. 1 is a front, top, left side perspective view of a wheel chock showing our new design;
FIG. 2 is a rear, bottom, left side perspective view thereof;
FIG. 3 is a top plan view thereof;
FIG. 4 is a bottom plan view thereof;
FIG. 5 is a front elevational view thereof;
FIG. 6 is a left side elevational view thereof;
FIG. 7 is a back elevational view thereof; and,
FIG. 8 is a right side elevational thereof.
The broken lines in the figures illustrate portions of the wheel chock that form no part of the claimed design.

1 Claim, 8 Drawing Sheets

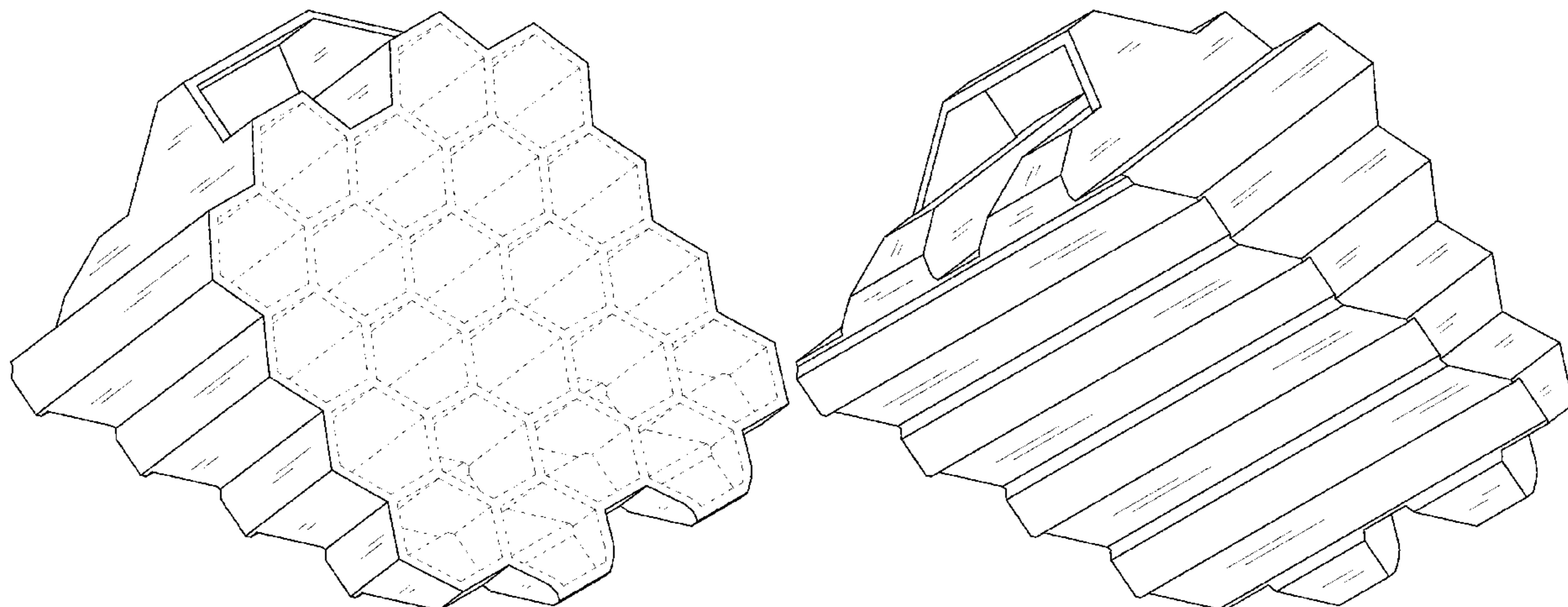

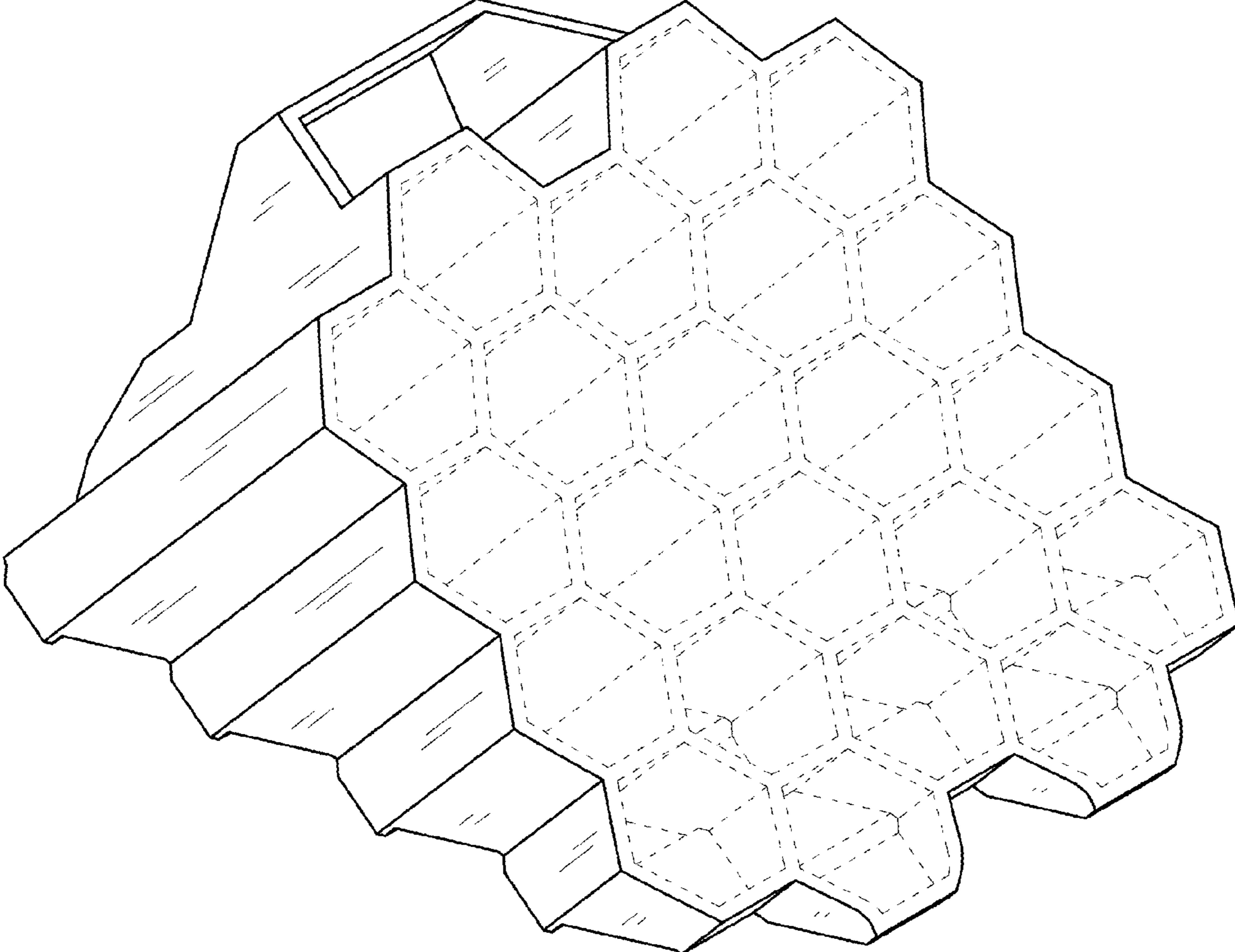

FIG. 1

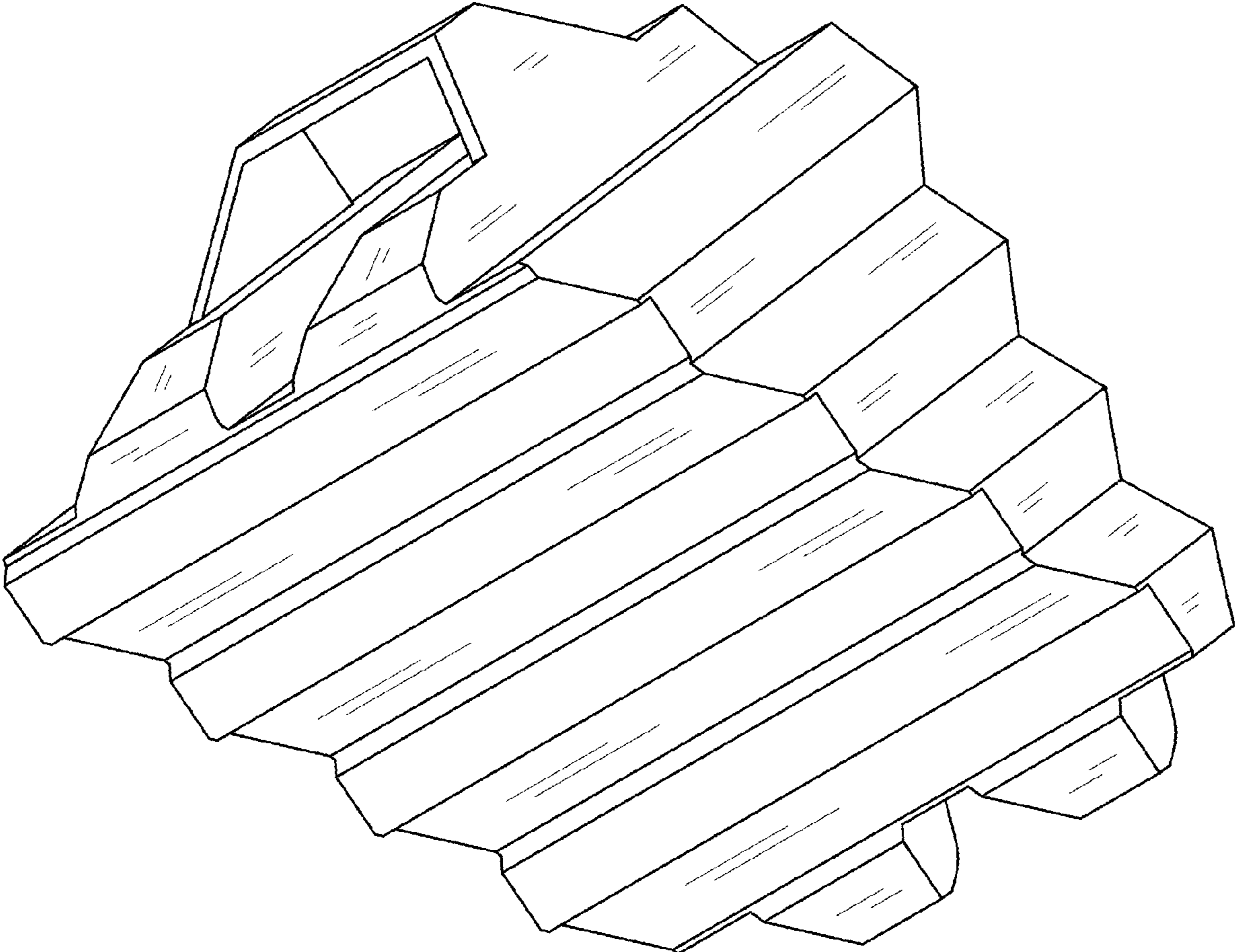

FIG. 2

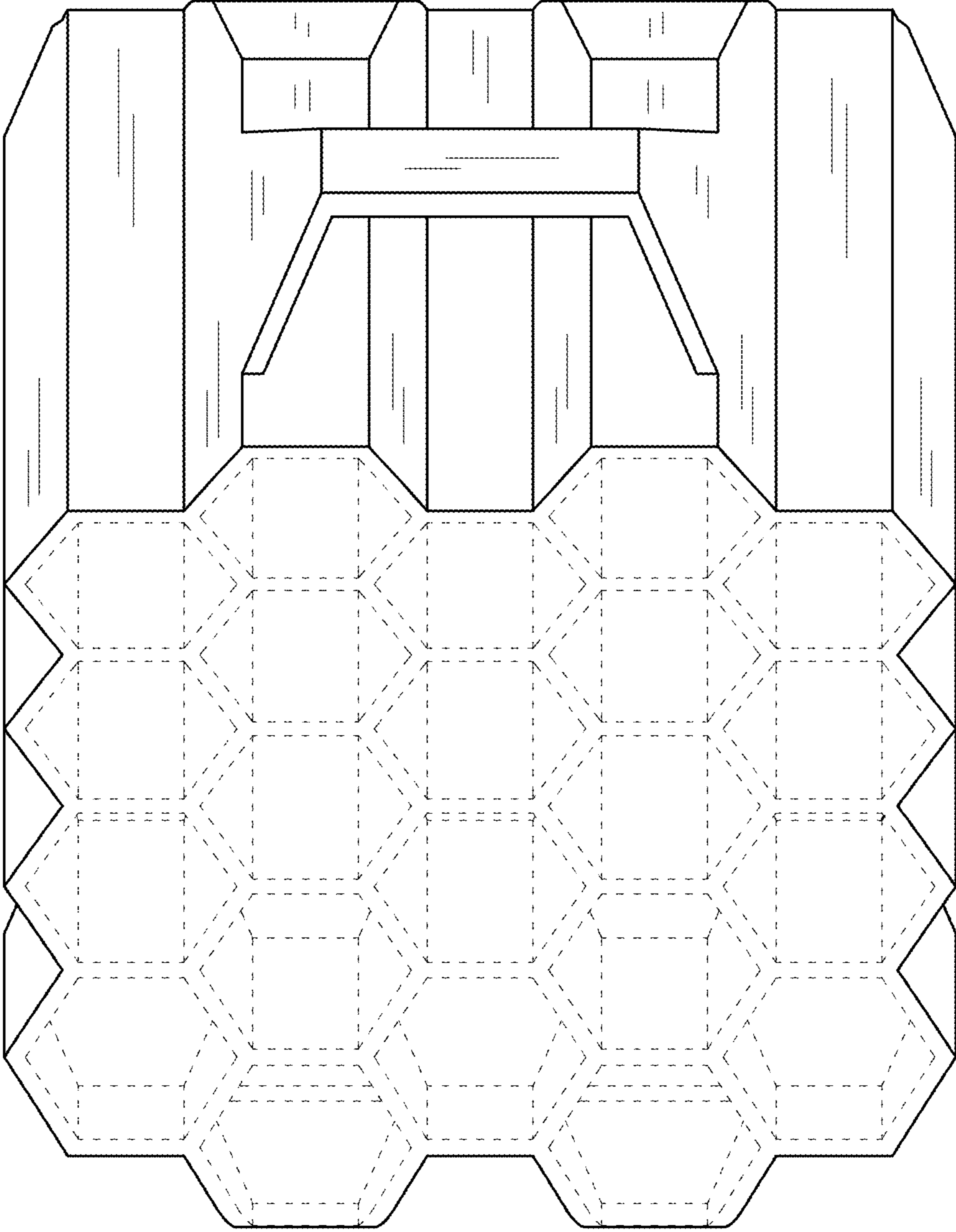

FIG. 3

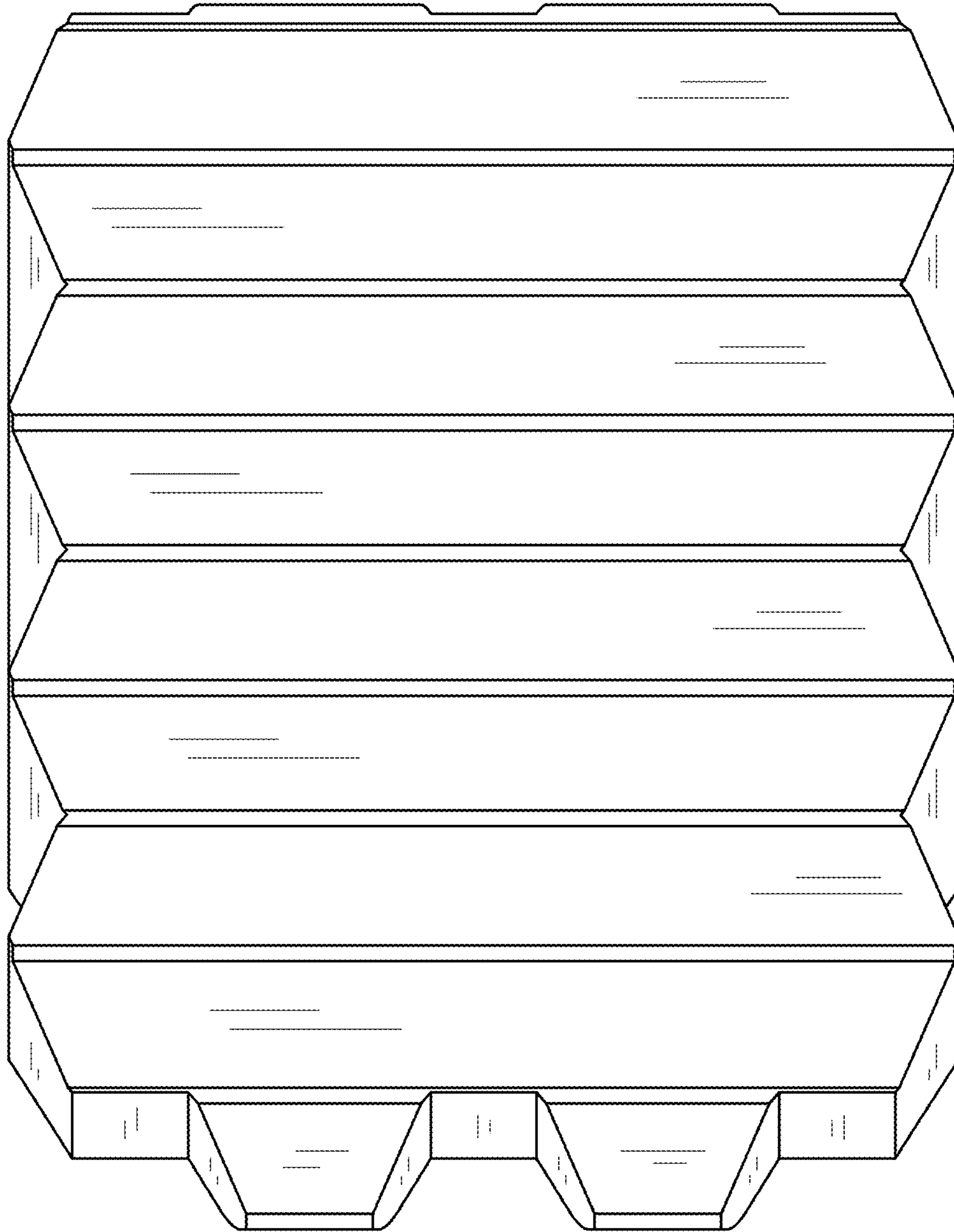

FIG. 4

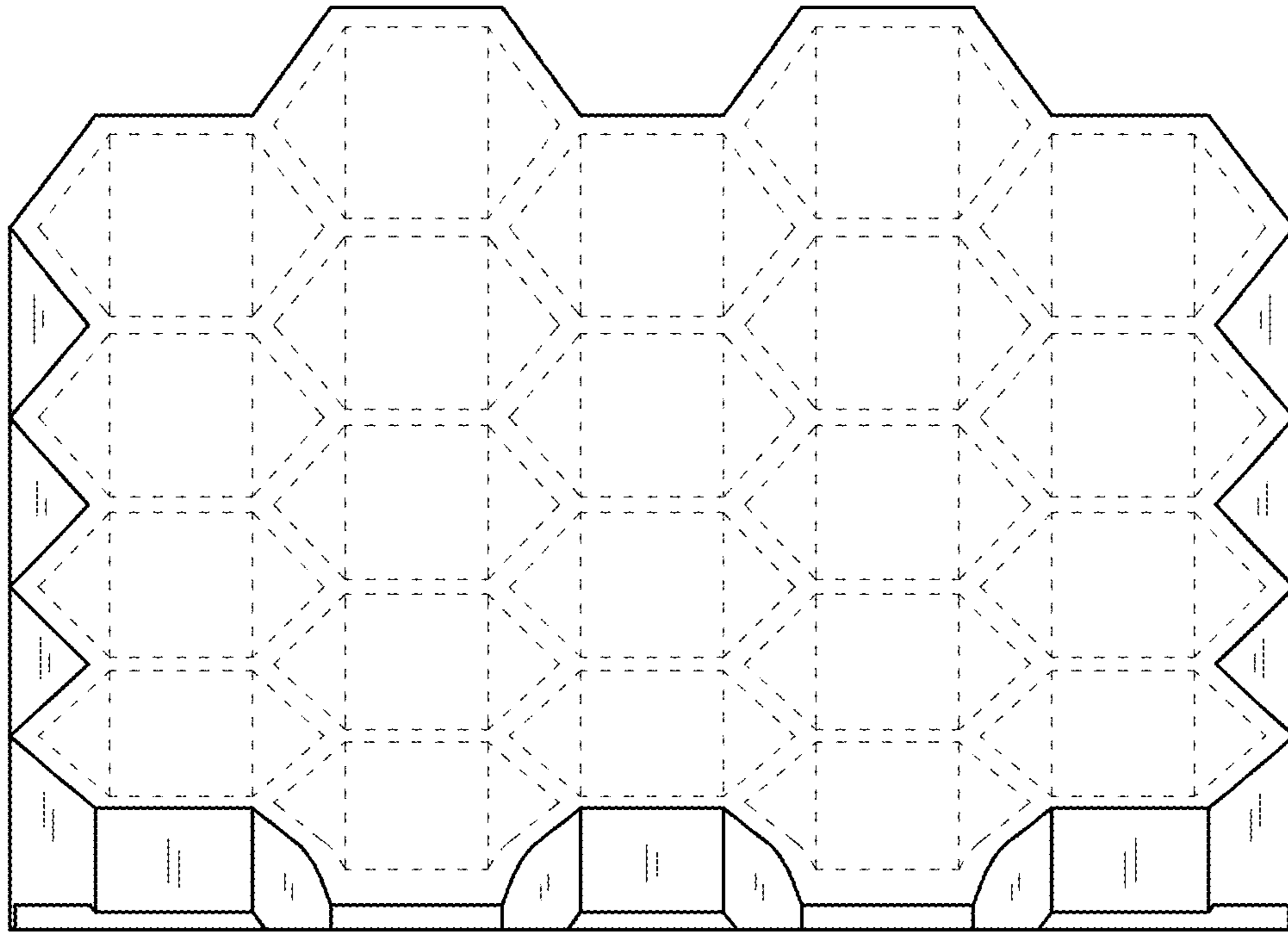

FIG. 5

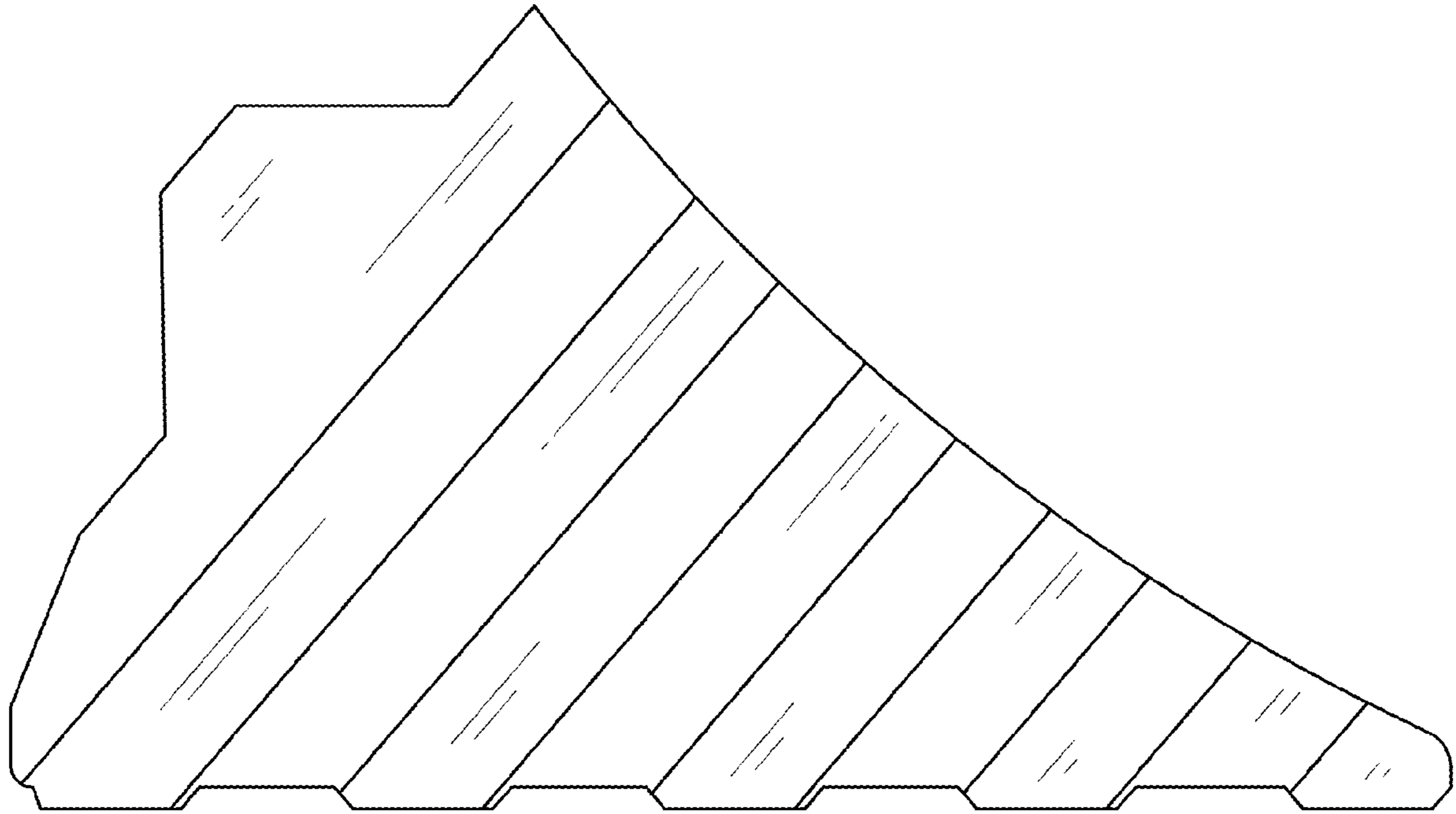

FIG. 6

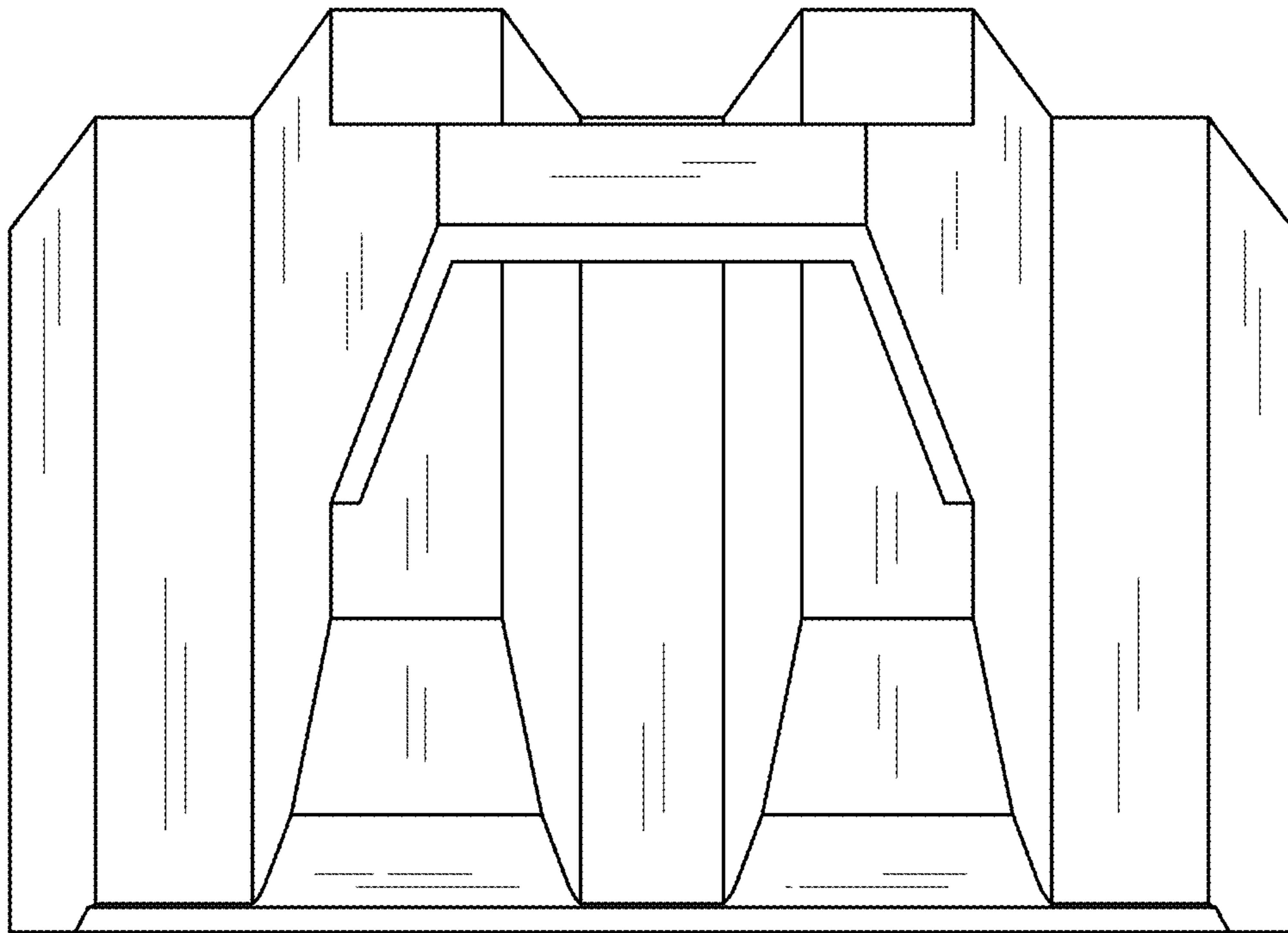

FIG. 7

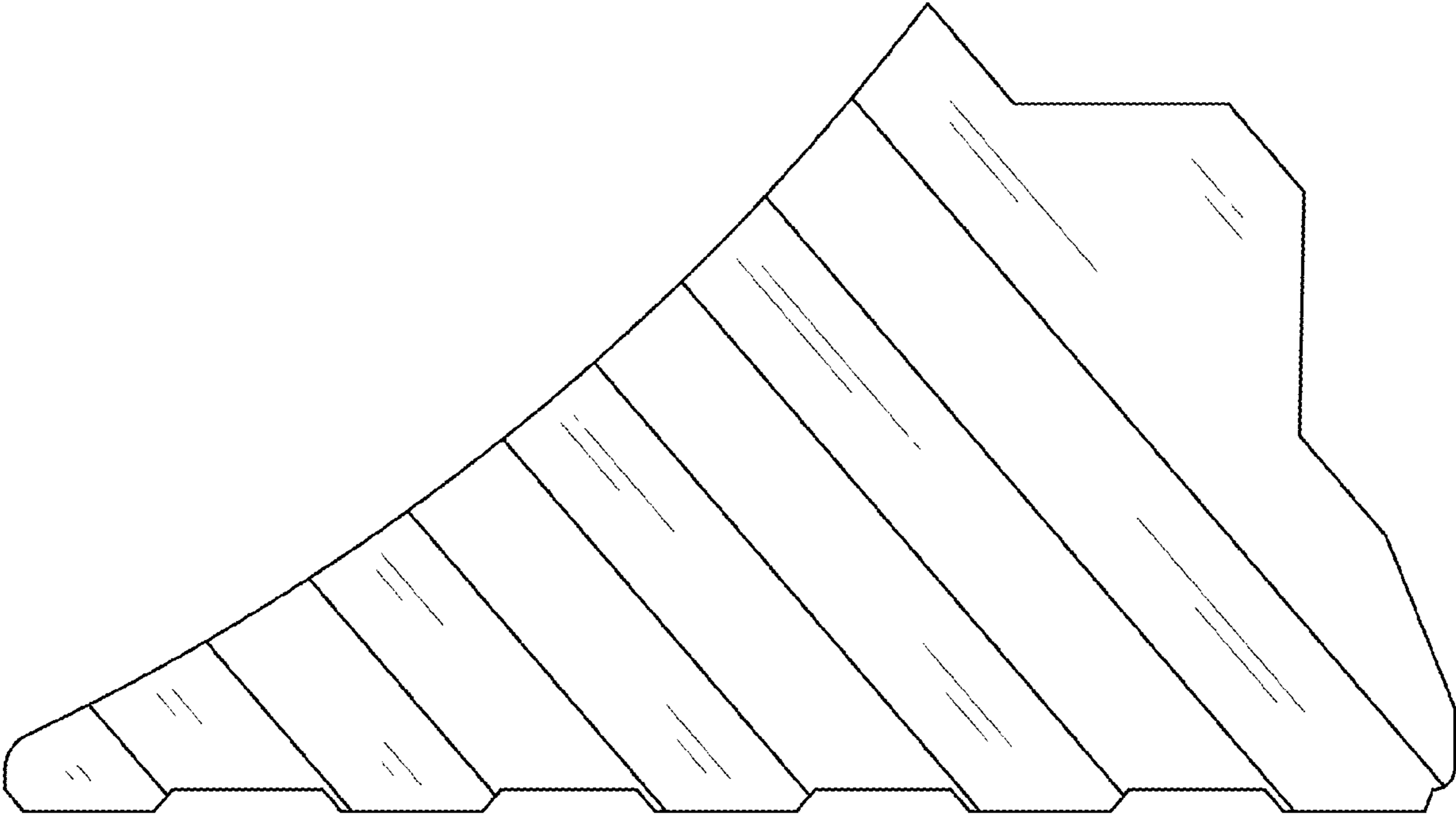

FIG. 8