



US00D927952S

(12) **United States Design Patent** (10) **Patent No.:** **US D927,952 S**  
**Tchakarov** (45) **Date of Patent:** **\*\* Aug. 17, 2021**

(54) **POLISHING OR GRINDING PAD ASSEMBLY WITH ABRASIVE DISK, SPACER, REINFORCEMENT AND PAD**

*Primary Examiner* — Darlington Ly  
(74) *Attorney, Agent, or Firm* — Burr & Forman, LLP

(71) Applicant: **Husqvarna AB**, Huskvarna (SE)  
(72) Inventor: **Tchavdar V. Tchakarov**, Monroe, MI (US)  
(73) Assignee: **HUSQVARNA AB**, Huskvarna (SE)

(57) **CLAIM**  
The ornamental design for the polishing or grinding pad assembly with abrasive disk, spacer, reinforcement and pad, as shown and described.

(\*\*) Term: **15 Years**

(21) Appl. No.: **29/709,106**

(22) Filed: **Oct. 11, 2019**

**Related U.S. Application Data**

(63) Continuation-in-part of application No. 29/615,569, filed on Aug. 30, 2017, now abandoned.

(51) **LOC (13) Cl.** ..... **08-05**

(52) **U.S. Cl.**  
USPC ..... **D8/70**

(58) **Field of Classification Search**  
USPC ..... D8/20, 61, 62, 63, 70; D15/124, 125, D15/126, 132, 138, 139, 140; D32/40  
(Continued)

(56) **References Cited**

**U.S. PATENT DOCUMENTS**

2,174,902 A 10/1939 Stratford  
2,225,193 A 12/1940 Benner et al.  
(Continued)

**FOREIGN PATENT DOCUMENTS**

CA 159666 S 7/2015  
CA 162792 S 7/2015  
(Continued)

**OTHER PUBLICATIONS**

“Confidential/experimental sale from Diamond Tool Supply, Inc. to Wagman Metal Products on Sep. 1, 2016,” 2 pages.

(Continued)

**DESCRIPTION**

FIG. 1 is a bottom perspective view of a polishing or grinding pad assembly with abrasive disk, spacer, reinforcement and pad of the present invention; FIG. 2 is a bottom plan view of the polishing or grinding pad assembly with abrasive disk, spacer, reinforcement and pad of FIG. 1; FIG. 3 is a side elevational view of the polishing or grinding pad assembly with abrasive disk, spacer, reinforcement and pad of FIG. 1; FIG. 4 is a side elevational view, opposite the view of FIG. 3, of the polishing or grinding pad assembly with abrasive disk, spacer, reinforcement and pad of FIG. 1; FIG. 5 is a rear elevational view of the polishing or grinding pad assembly with abrasive disk, spacer, reinforcement and pad of FIG. 1; FIG. 6 is a front elevational view, opposite the view of FIG. 5, of the polishing or grinding pad assembly with abrasive disk, spacer, reinforcement and pad of FIG. 1; FIG. 7 is an enlarged and exploded bottom perspective view of the polishing or grinding pad assembly with abrasive disk, spacer, reinforcement and pad of FIG. 1; FIG. 8 is an enlarged rear elevational view of the polishing or grinding pad assembly with abrasive disk, spacer, reinforcement and pad of FIG. 1; and, FIG. 9 is a top plan view of the polishing or grinding pad assembly with abrasive disk, spacer, reinforcement and pad of FIG. 1.

The even broken lines in the drawings illustrate portions of the polishing or grinding pad assembly with abrasive disk, spacer, reinforcement and pad that form no part of the claimed design.

**1 Claim, 4 Drawing Sheets**

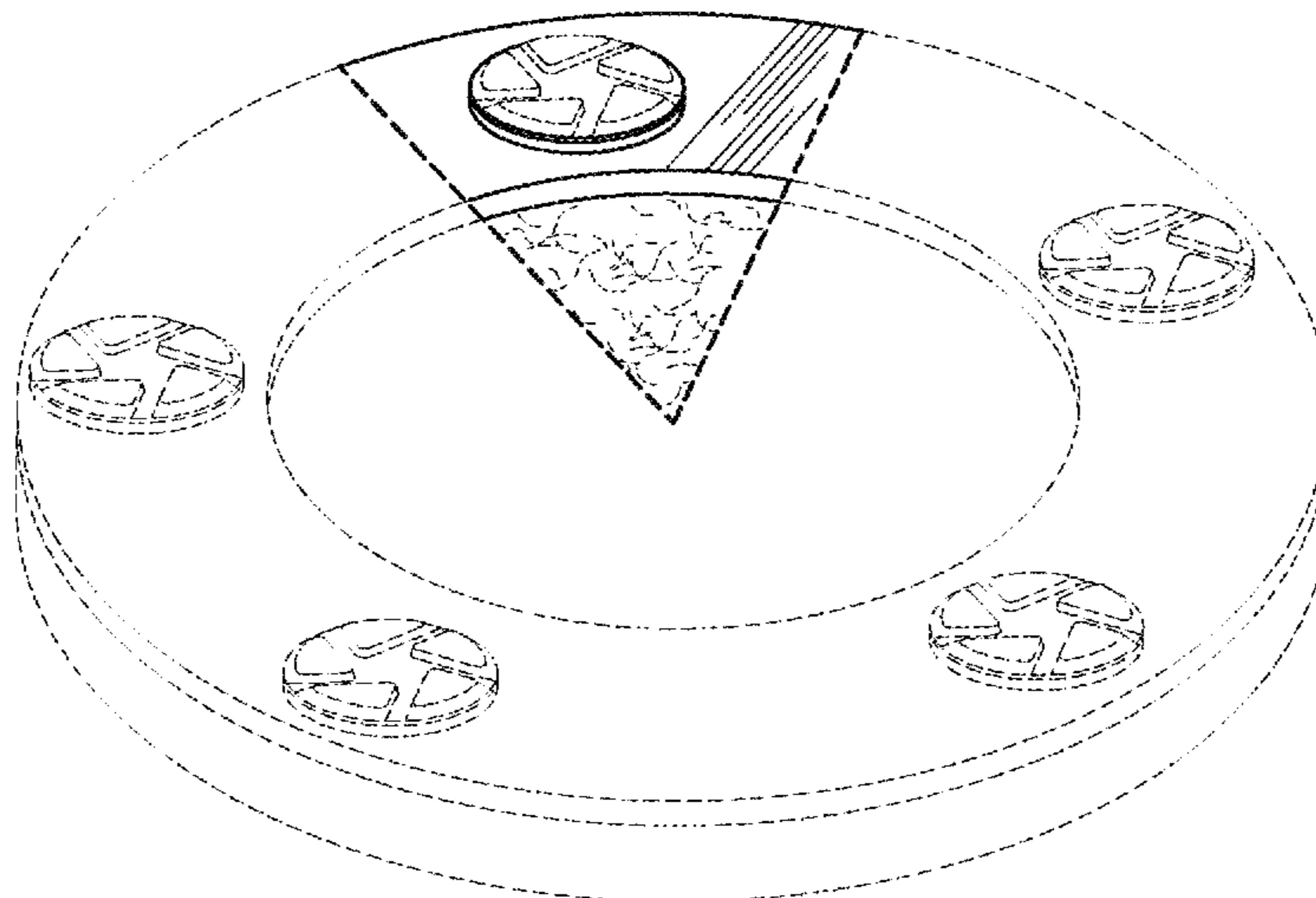



**US D927,952 S**

(58) **Field of Classification Search**  
 CPC . B24D 3/28; B24D 9/08; B24D 18/00; B24D  
 18/0027; B24B 37/24; B24B 37/26; B24B  
 55/102  
 See application file for complete search history.

(56) **References Cited**  
 U.S. PATENT DOCUMENTS

			7,059,801 B2	6/2006	Snyder et al.	
			7,094,138 B2 *	8/2006	Chang .....	B24B 55/10 451/359
			7,104,739 B2	9/2006	Lagler	
			7,144,194 B2	12/2006	Kipp, Jr.	
			7,147,548 B1	12/2006	Mehrabi	
			7,172,365 B2	2/2007	Lutz et al.	
			7,192,339 B1	3/2007	Harding	
			7,204,745 B2	4/2007	Thysell	
			7,223,161 B2	5/2007	Kodani et al.	
			7,261,623 B1	8/2007	Palushi	
			D559,063 S *	1/2008	Okamoto .....	D8/70
			7,326,106 B1	2/2008	Rogers et al.	
			D576,855 S *	9/2008	Okamoto .....	D8/70
			D580,728 S	11/2008	Umbrell	
			D581,237 S	11/2008	Okamoto et al.	
			D584,591 S *	1/2009	Tano .....	D8/70
			7,481,602 B2	1/2009	Lampley et al.	
			7,506,644 B2	3/2009	Park	
			7,520,800 B2	4/2009	Duescher	
			D592,029 S *	5/2009	Tano .....	D8/70
			D592,030 S *	5/2009	Tano .....	D8/70
			D600,989 S	9/2009	Tano et al.	
			D612,874 S *	3/2010	Nilsson .....	D15/138
			7,670,208 B2	3/2010	Thysell et al.	
			7,674,069 B2	3/2010	Stenzel	
			7,690,970 B2	4/2010	Palushaj	
			7,713,109 B2	5/2010	Estes	
			7,744,447 B2 *	6/2010	Kodani .....	B24D 7/06 451/548
			7,815,393 B2	10/2010	Snyder et al.	
			7,997,960 B2	8/2011	Williams, Sr.	
			D657,404 S	4/2012	Brandstetter	
			8,147,297 B2 *	4/2012	Hamm .....	B24B 41/047 451/353
			8,176,909 B2	5/2012	Ilgner	
			8,192,255 B2	6/2012	Gallup et al.	
			8,251,780 B2 *	8/2012	Ward .....	B24B 7/186 451/353
			8,272,924 B2	9/2012	Van Eijden et al.	
			D678,745 S *	3/2013	Nguyen .....	D8/70
			8,464,420 B2	6/2013	Ye	
			D694,081 S	11/2013	Wright	
			D708,497 S	7/2014	Hoglund	
			8,790,164 B2 *	7/2014	Rivard .....	B24D 9/003 451/490
			D731,448 S *	6/2015	Kinoshita .....	D13/182
			D732,917 S *	6/2015	Valentini .....	D8/70
			9,050,625 B1	6/2015	Bonachea Ruiz	
			D743,456 S *	11/2015	Shinozaki .....	D15/126
			9,174,326 B2	11/2015	Ahonen	
			9,314,899 B2 *	4/2016	Puchegger .....	B24B 7/18
			9,580,916 B2	2/2017	Tchakarov et al.	
			D795,666 S	8/2017	Tchakarov et al.	
			9,925,645 B2 *	3/2018	Song .....	B24B 7/186
			10,011,999 B2	7/2018	Tchakarov et al.	
			10,046,438 B2	8/2018	Tchakarov	
			10,092,159 B2	10/2018	Tchakarov	
			10,160,092 B2 *	12/2018	Lefevre .....	B24B 37/26
			D837,015 S	1/2019	Tchakarov et al.	
			10,244,914 B2	4/2019	Tchakarov	
			10,246,885 B2	4/2019	Tchakarov	
			D854,902 S *	7/2019	Tchakarov .....	D8/70
			D873,108 S *	1/2020	Tchakarov .....	D8/70
			10,625,392 B2 *	4/2020	Murakami .....	C08G 18/755
			2001/0048854 A1	12/2001	Carter, Jr.	
			2003/0029132 A1	2/2003	Ward	
			2004/0009744 A1	1/2004	Conley et al.	
			2005/0164620 A1 *	7/2005	Amamoto .....	B23C 5/006 451/548
			2005/0172428 A1 *	8/2005	Thysell .....	A47L 11/164 15/4
			2005/0227600 A1 *	10/2005	Fisher .....	B24D 9/085 451/538
			2006/0025059 A1	2/2006	Gueorguiev et al.	
			2006/0073776 A1	4/2006	Gallup	
			2006/0211353 A1	9/2006	Kodani et al.	
2,425,368 A	8/1947	Doermann				
2,556,983 A	6/1951	Root				
2,662,454 A	12/1953	Whiteman				
2,819,568 A	1/1958	Kasick				
2,963,059 A	12/1960	Grub				
3,121,982 A	2/1964	Miller				
3,452,381 A	7/1969	Bratti				
3,464,166 A	9/1969	Bouvier				
3,487,589 A	1/1970	Binkley				
3,517,466 A	6/1970	Bouvier				
3,591,884 A	7/1971	Grueb				
3,686,703 A	8/1972	Ray				
3,823,516 A	7/1974	Christian				
3,934,377 A	1/1976	Tertinek				
4,058,936 A	11/1977	Marton				
4,271,557 A	6/1981	Caron				
4,502,174 A	3/1985	Rones				
4,554,765 A	11/1985	Grimes et al.				
D284,969 S	8/1986	Olovsson				
4,694,615 A	9/1987	MacKay, Jr.				
4,724,567 A	2/1988	Rones				
4,781,556 A	11/1988	Paul				
4,874,478 A	10/1989	Ishak et al.				
4,939,872 A	7/1990	Revelin et al.				
5,020,280 A	6/1991	O'Reilly				
5,054,245 A	10/1991	Coty				
5,076,023 A	12/1991	Saguchi				
5,170,595 A	12/1992	Wiand				
5,174,795 A	12/1992	Wiand				
5,247,765 A	9/1993	Quintana				
5,372,452 A	12/1994	Hodgson				
5,449,406 A	9/1995	Presti, Jr.				
5,452,853 A	9/1995	Shook et al.				
5,477,580 A	12/1995	Buysse				
D367,743 S	3/1996	Krause et al.				
5,567,503 A	10/1996	Sexton et al.				
5,586,930 A	12/1996	Hayashi et al.				
5,605,493 A	2/1997	Donatelli et al.				
5,607,345 A	3/1997	Barry et al.				
5,632,570 A	5/1997	Balling				
5,632,790 A	5/1997	Wiand				
5,683,143 A	11/1997	Peterson et al.				
5,782,682 A	7/1998	Han et al.				
5,807,022 A	9/1998	McCleary				
5,882,249 A	3/1999	Ferland				
5,970,559 A	10/1999	Christy				
6,059,644 A	5/2000	Manor et al.				
6,196,911 B1	3/2001	Preston et al.				
6,206,771 B1	3/2001	Lehman				
6,234,886 B1	5/2001	Rivard et al.				
6,261,164 B1	7/2001	Rivard et al.				
6,298,518 B1	10/2001	Umbrell				
6,299,522 B1	10/2001	Lee				
6,371,842 B1 *	4/2002	Romero .....	B24D 11/001 451/540			
6,382,922 B1	5/2002	Lewis et al.				
6,536,989 B2	3/2003	Rijkers				
6,625,951 B1	9/2003	McCarthy				
6,641,627 B2	11/2003	Keipert et al.				
6,739,963 B1	5/2004	Mas Garcia				
6,830,506 B2	12/2004	Catalfamo				
D503,602 S *	4/2005	Hede .....	D8/70			
D506,376 S *	6/2005	Hede .....	D8/70			
D509,121 S *	9/2005	Hede .....	D8/70			
D510,850 S *	10/2005	Boler, Jr. ....	D8/70			
6,971,821 B1	12/2005	Mansour et al.				
7,004,676 B2	2/2006	Williams				
7,033,258 B2	4/2006	Jordan				

(56)

References Cited

U.S. PATENT DOCUMENTS

2007/0254568 A1\* 11/2007 Park ..... B24B 41/047  
451/548

2007/0292207 A1 12/2007 Reed et al.

2008/0108286 A1\* 5/2008 Thysell ..... B24B 7/186  
451/353

2008/0176498 A1\* 7/2008 Rossi ..... B24B 7/186  
451/508

2008/0311826 A1 12/2008 Thysell

2009/0053982 A1 2/2009 Popov

2009/0190999 A1 7/2009 Copoulos

2009/0191799 A1\* 7/2009 Rivard ..... B24D 13/16  
451/259

2010/0136889 A1 6/2010 Kilgren et al.

2010/0190421 A1 7/2010 Hamm et al.

2010/0240282 A1 9/2010 Young

2011/0053468 A1 3/2011 Vontell

2011/0092136 A1 4/2011 Thysell

2011/0195644 A1 8/2011 Gallup et al.

2011/0222966 A1 9/2011 Allen et al.

2011/0223845 A1 9/2011 Van Der Veen et al.

2011/0300784 A1 12/2011 Tchakaov et al.

2012/0270483 A1 10/2012 Bae et al.

2013/0000246 A1 1/2013 Bourelle

2013/0225051 A1 8/2013 Vankouenberg

2013/0324021 A1\* 12/2013 Ryan ..... B24D 13/147  
451/529

2014/0154961 A1 6/2014 Fiore

2015/0328742 A1 11/2015 Schuele et al.

2016/0083967 A1 3/2016 Tchakarov et al.

2016/0136772 A1 5/2016 Littlefield et al.

2016/0144485 A1 5/2016 Ruan et al.

2016/0221155 A1 8/2016 Song et al.

2017/0129067 A1\* 5/2017 Young ..... A47L 11/164

2017/0361414 A1 12/2017 Tchakarov

2017/0361423 A1 12/2017 Tchakarov

2018/0200857 A1 7/2018 Tchakarov

2018/0206690 A1 7/2018 Tchakarov

FOREIGN PATENT DOCUMENTS

CA 162793 S 7/2015

CA 162794 S 7/2015

CA 162795 S 7/2015

CA 162796 S 7/2015

CA 162797 S 7/2015

DE 20120137 U1 2/2002

DE 102009008261 A1 8/2010

DE 202015101442 U1 5/2015

EP 3 348 352 A1 7/2018

JP S49-77293 U 7/1974

JP S56-94267 U 7/1981

JP H01-117854 U 8/1989

JP 2001-526593 A 12/2001

JP 2004-025401 A 1/2004

JP 2004-276197 A 10/2004

JP 2006068885 A 3/2006

JP 2008-532781 A 8/2008

JP 2012-232378 A 11/2012

JP 2014-513635 A 6/2014

KR 100816026 B1 3/2008

KR 100853547 B1 8/2008

WO 2008/065210 A1 6/2008

WO 2017/053737 A1 3/2017

OTHER PUBLICATIONS

“Diamond Tools for Construction Stone,” EHWA Diamond Ind. Co. Ltd. Catalogue, Published 2016, 60 pages.

Diamond Tool Supply, Inc., “Floor Maintenance and Cleaning—Monroe” Catalog, (published prior to Sep. 2014).

Diamond Tool Supply, Inc., “Floor Maintenance and Cleaning—Vortex” Catalog, (published on or before May 2013).

Diamond Tool Supply, Inc., “Monroe Floor Polishing Systems,” www.diamondtoolsupply.com, published prior to Sep. 24, 2015, 14 pages.

Diamond Tool Supply, Inc., “Tools for Concrete” Catalog, (published on or before May 2013).

Diamond Tool Supply, Inc., “Tools for Concrete” Catalog, (published prior to Sep. 2014).

Diamond Tool Supply, Inc., “Tools for Stone” Catalog, (published prior to Sep. 2014).

Diamond Tool Supply, Inc., Various polishing and grinding parts, www.diamondtoolsupply.com, published prior to Sep. 24, 2015, 26 pages.

HTC, “Professional Floor Systems” Product catalog 2014, www.htc-floorsystems.com, 2014.

HTC, “Professional Floor Systems” Product catalogue 2015, www.htc-floorsystems.com, 2015.

Si GmbH, The System Manufacturer, Brochure Edition 12, Jan. 2017, 83 pages.

Wagman Metal Products Inc., “Concrete Finishing Tools” Catalog, (published prior to Sep. 23, 2016).

International Search Report and Written Opinion for International Application No. PCT/US2016/053355 dated Dec. 22, 2016.

International Search Report and Written Opinion for International Application No. PCT/US2018/048845 dated Dec. 5, 2018.

\* cited by examiner



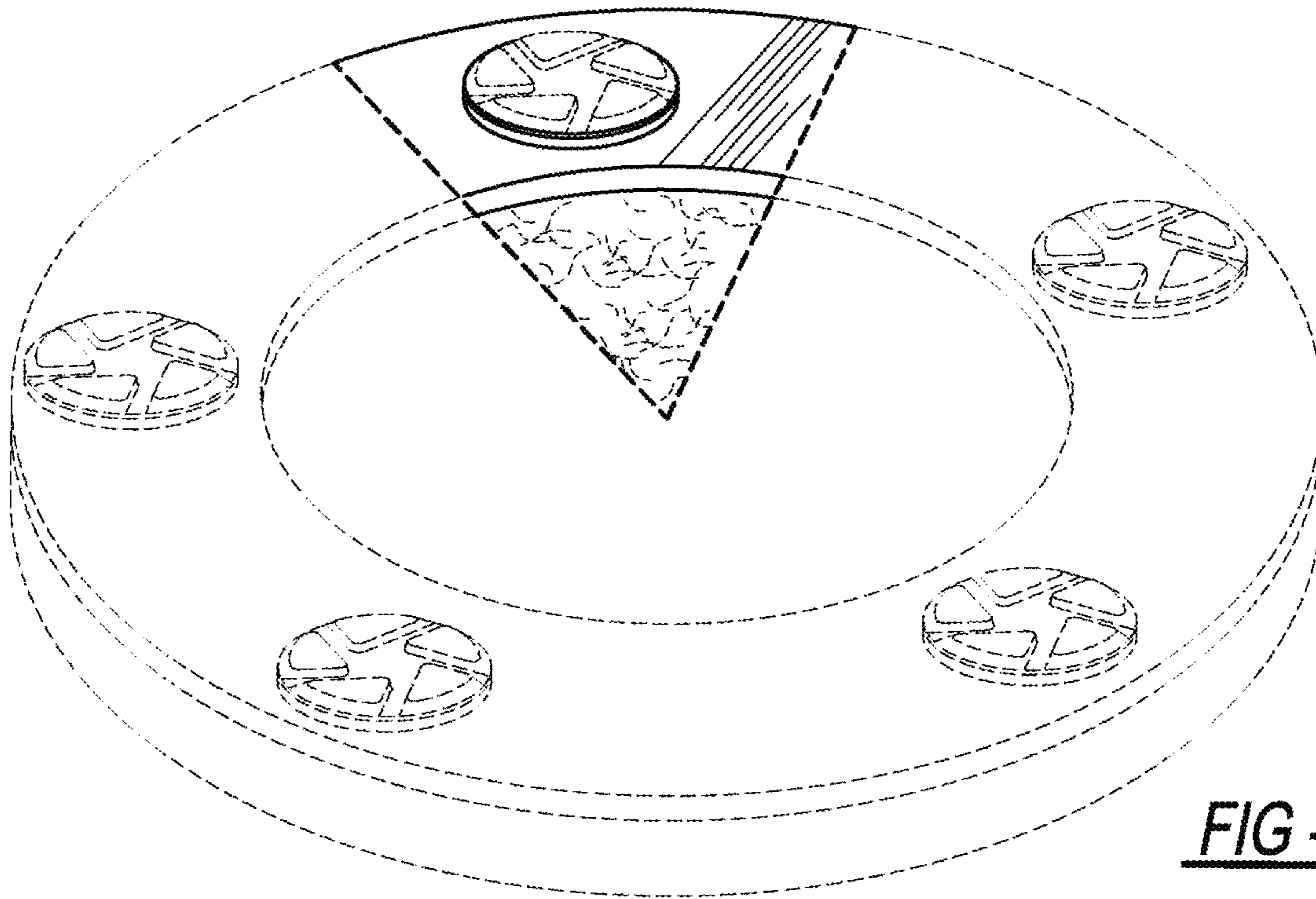

FIG - 1

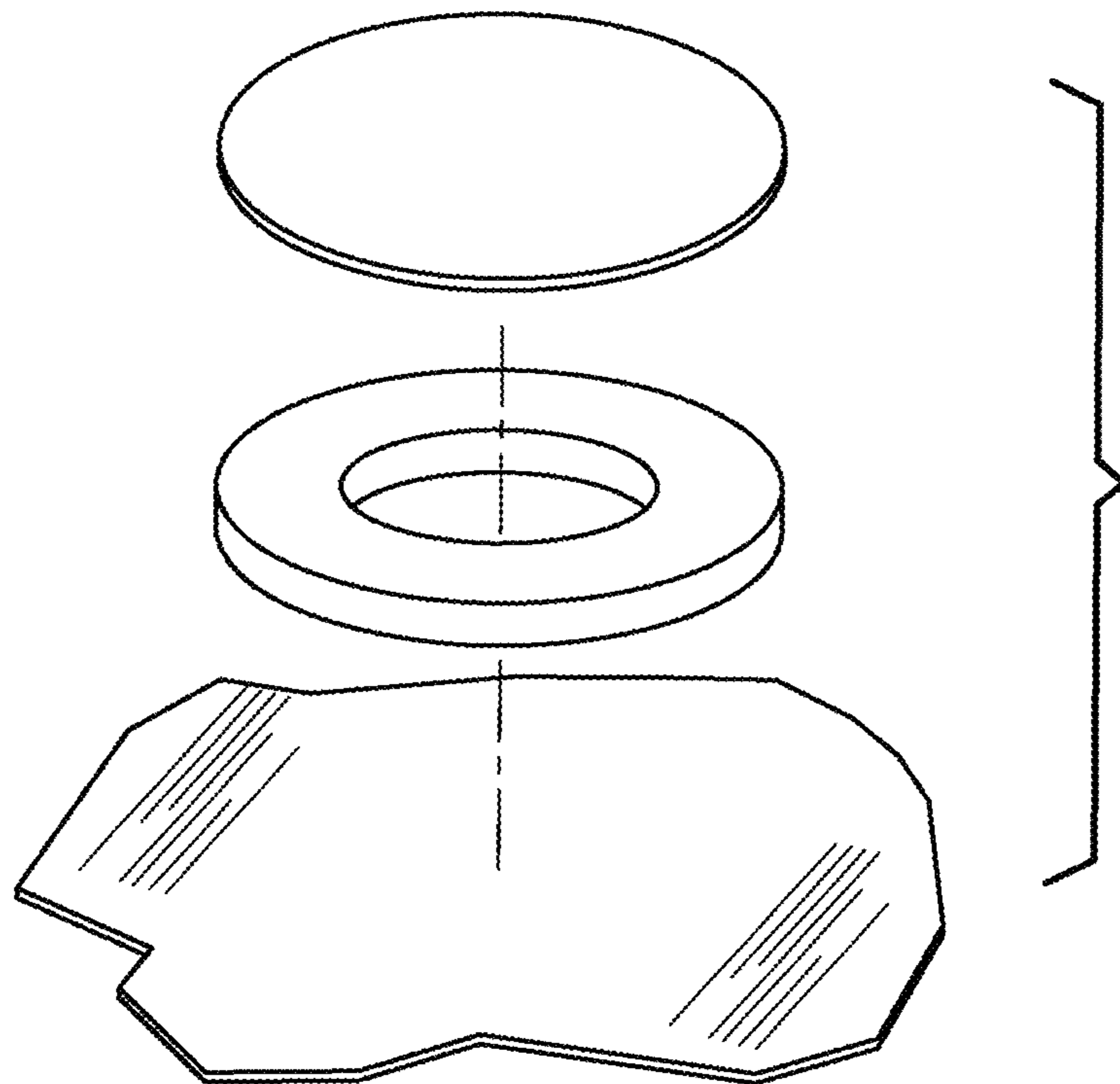

FIG - 7

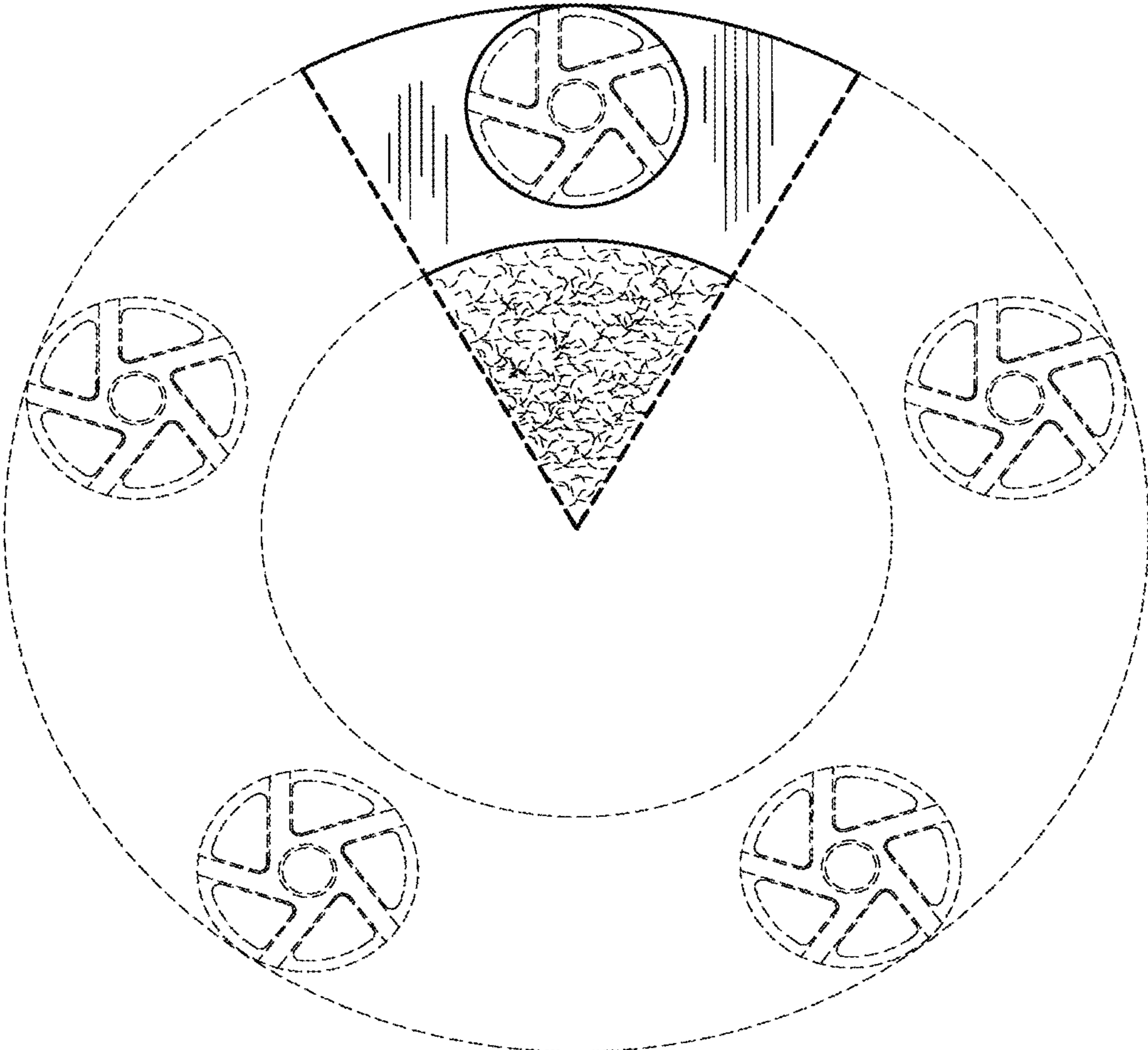

FIG - 2

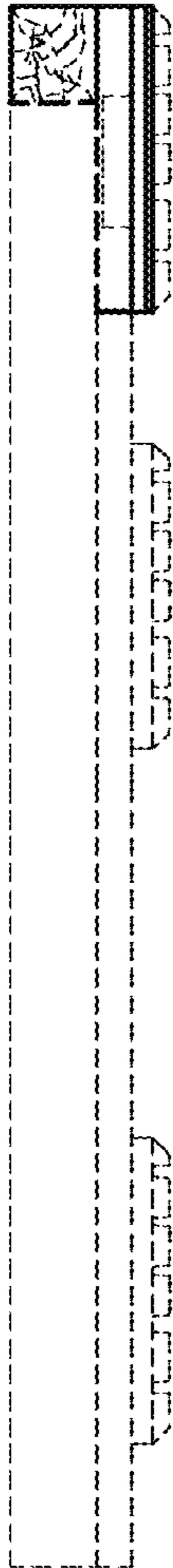

FIG - 3

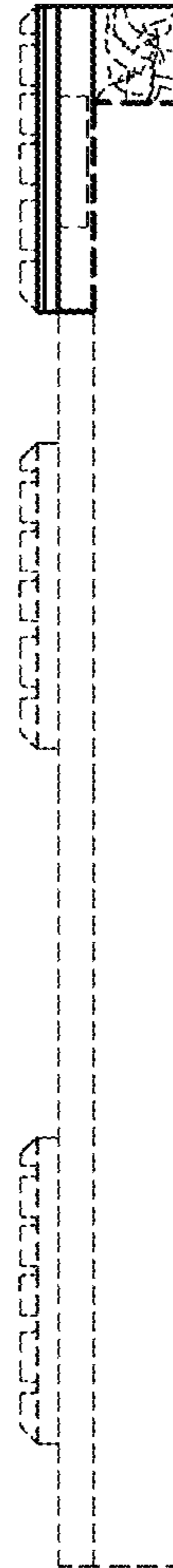

FIG - 4



FIG - 5

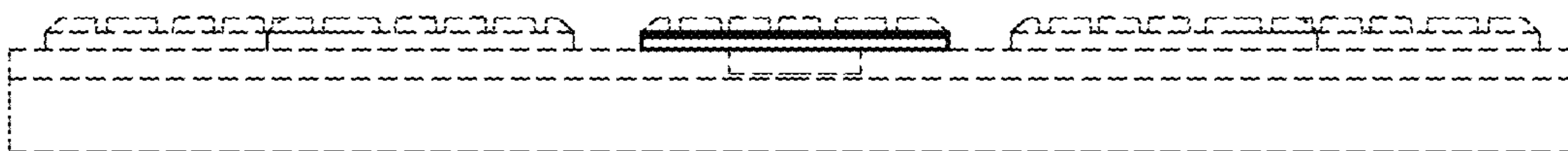

FIG - 6

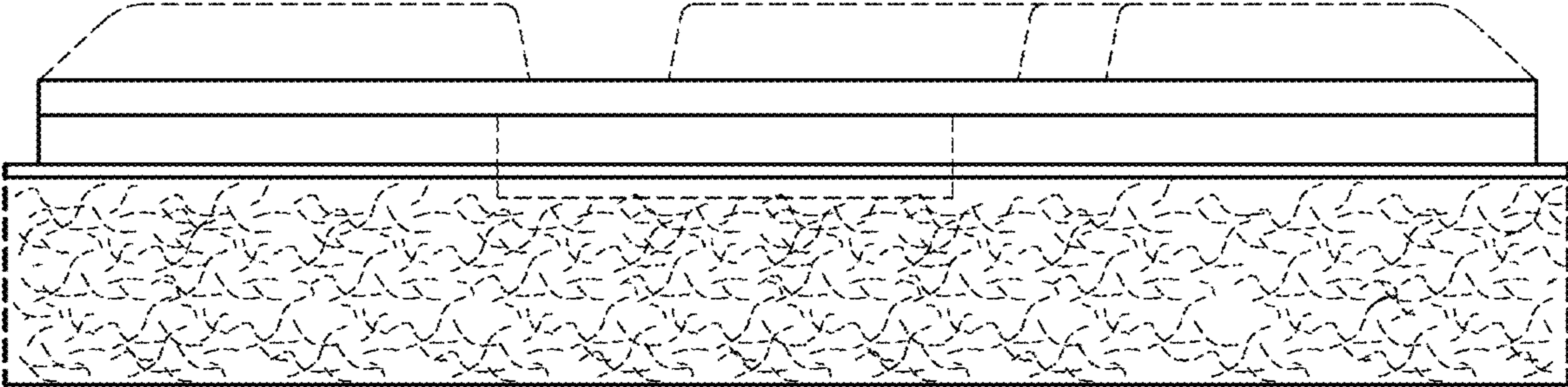

FIG - 8

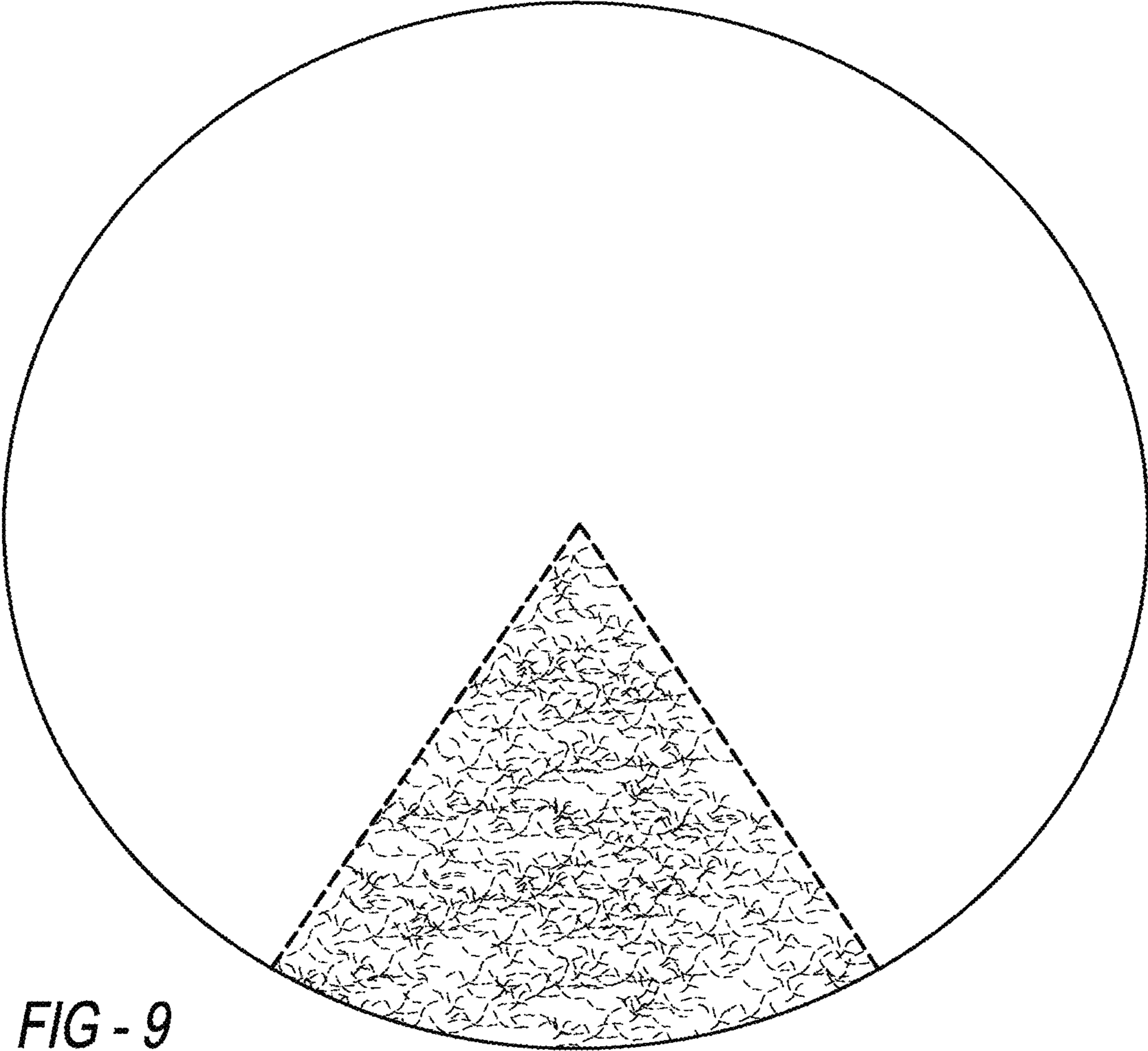

FIG - 9