



US00D927851S

(12) **United States Design Patent** (10) **Patent No.:** **US D927,851 S**
Chasseriaux et al. (45) **Date of Patent:** **** Aug. 17, 2021**

(54) **TRAVEL KIT**

(74) *Attorney, Agent, or Firm* — Gregory L. Mayback;
Dickinson Wright PLLC

(71) Applicant: **Rimowa GmbH**, Cologne (DE)

(72) Inventors: **Sylvain Chasseriaux**, Paris (FR);
François Rybarczyk, Nice (FR);
Maxime Loiseau, Paris (FR)

(57) **CLAIM**

The ornamental design for a travel kit, as shown and described.

(73) Assignee: **Rimowa GMBH**, Cologne (DE)

(**) Term: **15 Years**

DESCRIPTION

(21) Appl. No.: **35/508,887**

1.-4. Travel kit
FIG. 1.1 is a side perspective view of a travel kit showing our new design;

(22) Filed: **Dec. 13, 2019**

FIG. 1.2 is a top side elevation view thereof;

(80) **Hague Agreement Data**

Int. Filing Date: **Dec. 13, 2019**

Int. Reg. No.: **DM/206576**

Int. Reg. Date: **Dec. 13, 2019**

Int. Reg. Pub. Date: **Mar. 27, 2020**

FIG. 1.3 is a bottom side elevation view thereof;

FIG. 1.4 is a front side elevation view thereof;

FIG. 1.5 is a back side elevation view thereof;

FIG. 1.6 is a left side elevation view thereof;

FIG. 1.7 is a right side elevation view thereof;

FIG. 2.1 is a side perspective view thereof;

FIG. 2.2 is a top side elevation view thereof;

FIG. 2.3 is a bottom side elevation view thereof;

FIG. 2.4 is a front side elevation view thereof;

FIG. 2.5 is a back side elevation view thereof;

FIG. 2.6 is a left side elevation view thereof;

FIG. 2.7 is a right side elevation view thereof;

(30) **Foreign Application Priority Data**

Jun. 14, 2019 (EM) 006580668

(51) **LOC (13) Cl.** **03-01**

(52) **U.S. Cl.**
USPC **D3/294**

(58) **Field of Classification Search**

USPC D3/201, 247, 249–253, 273, 294

CPC A45C 1/06; A45C 3/08; A45C 11/00

See application file for complete search history.

FIG. 3.1 is a side perspective view thereof;

FIG. 3.2 is a top side elevation view thereof;

FIG. 3.3 is a bottom side elevation view thereof;

FIG. 3.4 is a front side elevation view thereof;

FIG. 3.5 is a back side elevation view thereof;

FIG. 3.6 is a left side elevation view thereof;

FIG. 3.7 is a right side elevation view thereof;

FIG. 4.1 is a side perspective view thereof;

FIG. 4.2 is a top side elevation view thereof;

FIG. 4.3 is a bottom side elevation view thereof;

FIG. 4.4 is a front side elevation view thereof;

FIG. 4.5 is a back side elevation view thereof;

FIG. 4.6 is a left side elevation view thereof; and

FIG. 4.7 is a right side elevation view thereof.

The broken lines shown in the figures depict portions of the travel kit that form no part of the claimed design. The

(56) **References Cited**

U.S. PATENT DOCUMENTS

D62,007 S * 2/1923 Hovesepan D3/247

D187,240 S * 2/1960 Harkins et al. D3/247

D491,358 S * 6/2004 Hofman D3/273

D516,807 S * 3/2006 Richardson D3/273

(Continued)

(Continued)

Primary Examiner — Holly E Thurman

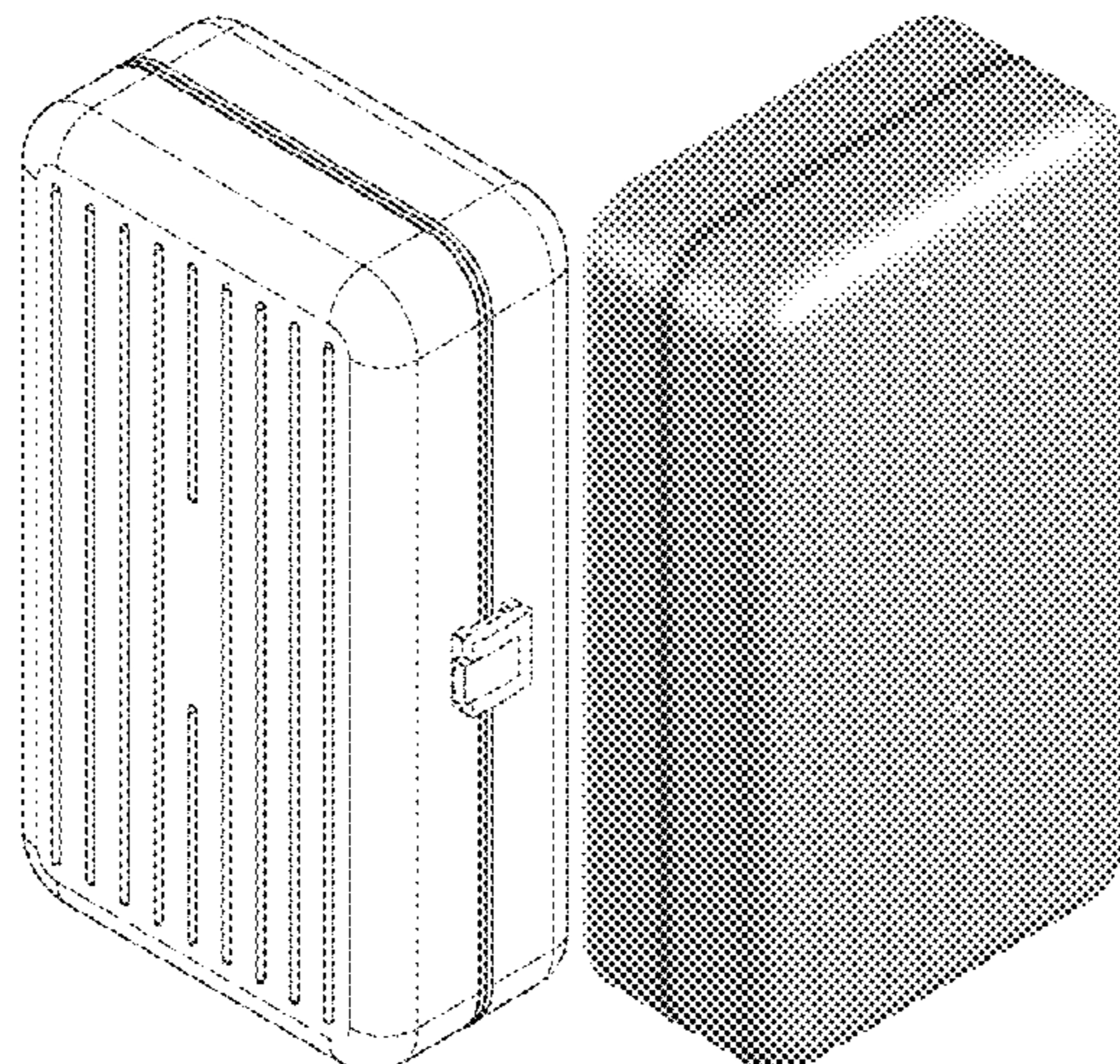

coloring shown on the claimed design in FIGS. 4.1 to 4.7
forms no part of the claimed design.

1 Claim, 28 Drawing Sheets

(56)

References Cited

U.S. PATENT DOCUMENTS

D527,182 S	*	8/2006	Ham	D3/274
D579,201 S	*	10/2008	Galli	D3/273
D713,641 S	*	9/2014	Batle	D3/247
D718,048 S	*	11/2014	Hsu	D3/273
D718,049 S	*	11/2014	Hsu	D3/273
D807,579 S	*	1/2018	Wu	D27/189
D839,583 S	*	2/2019	Cao	D3/201

* cited by examiner

1.1

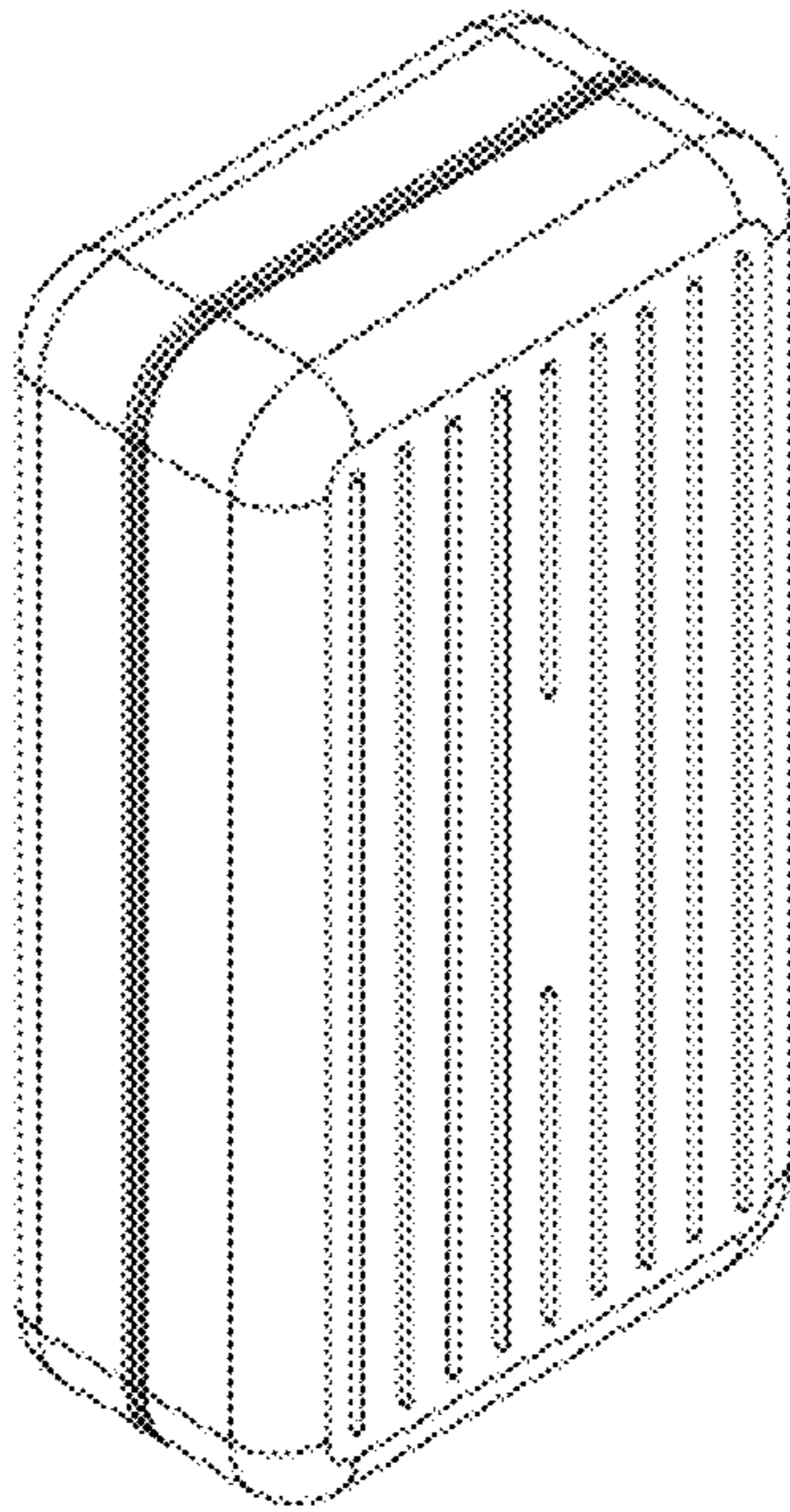

1.2

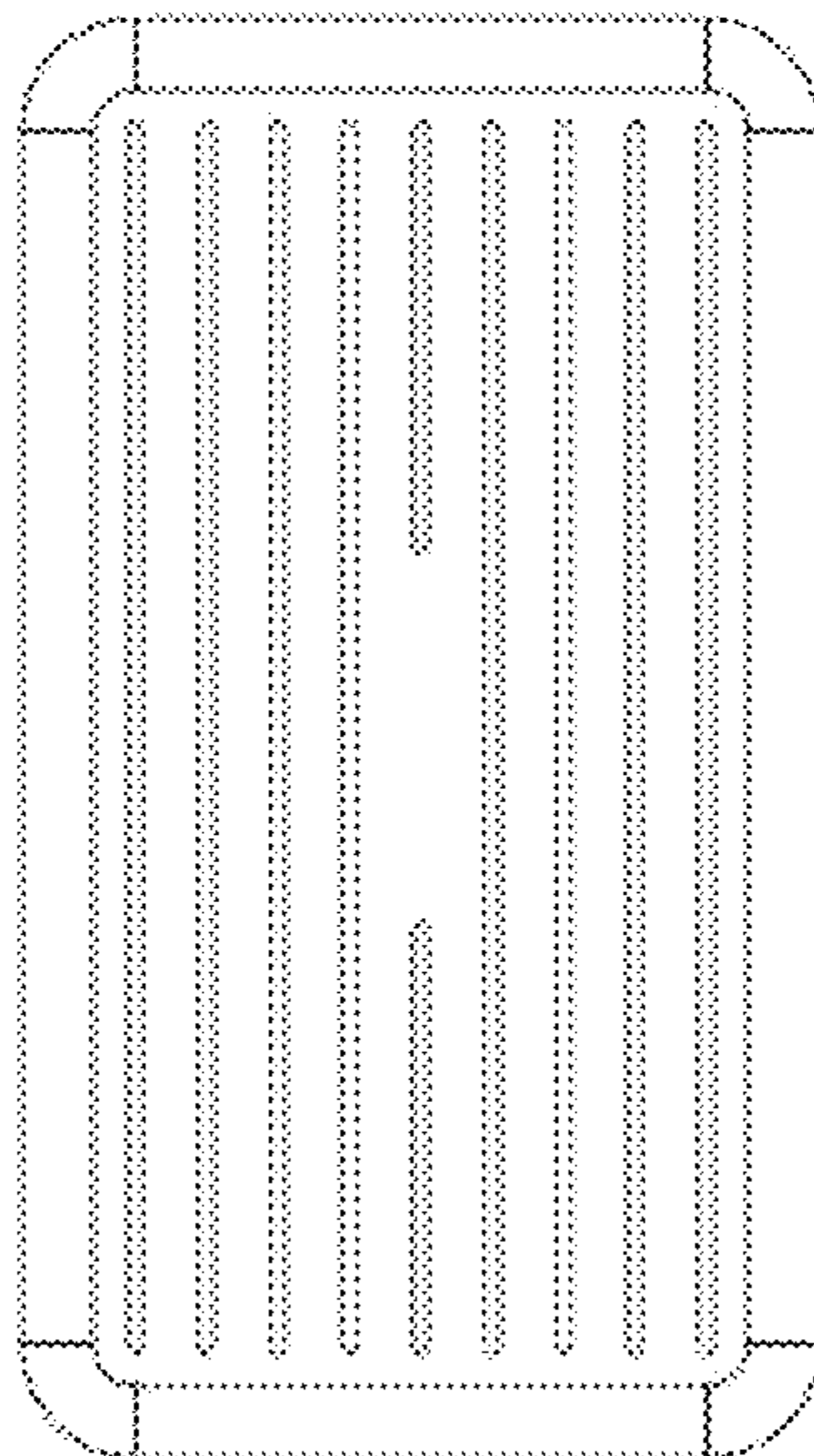

1.3

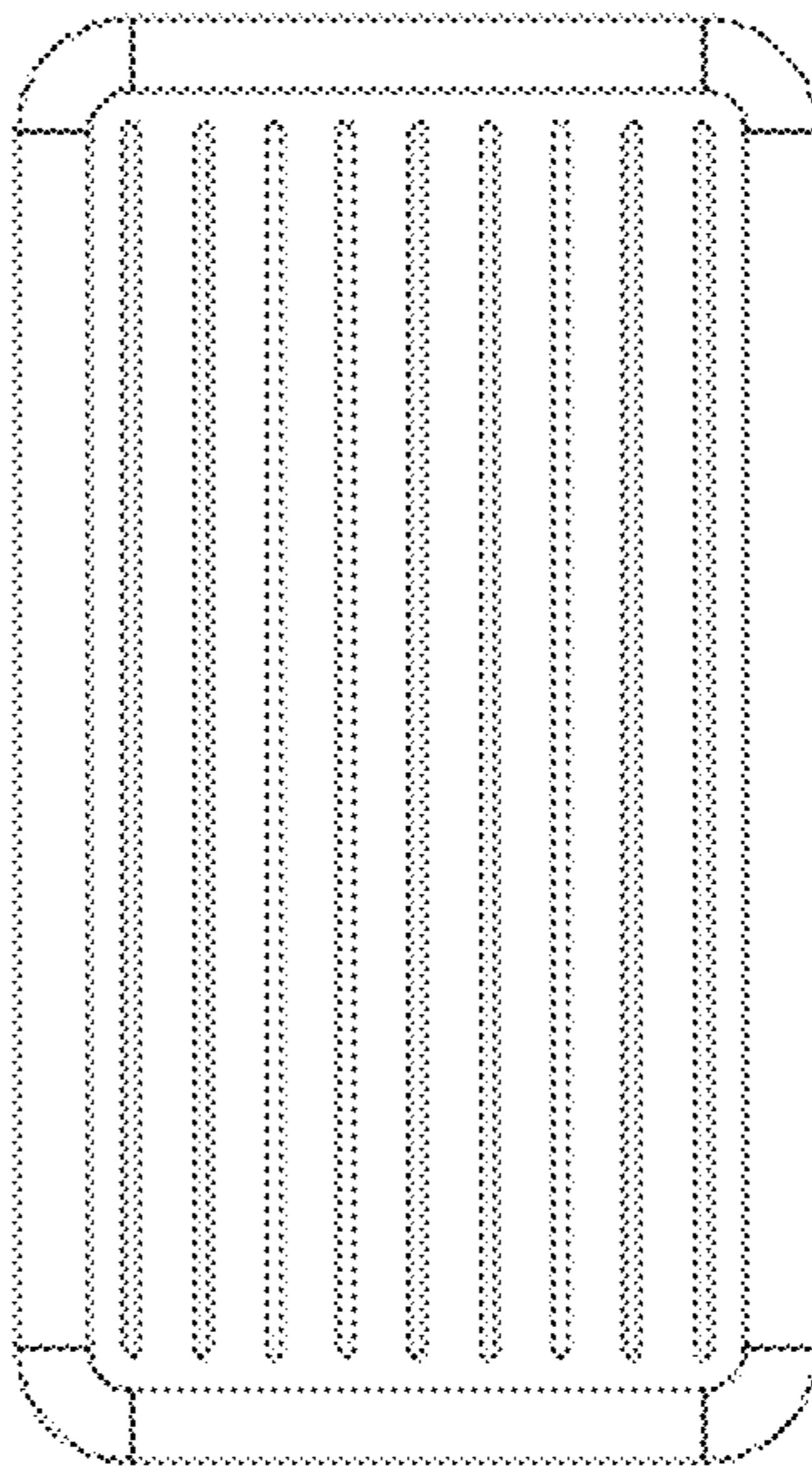

1.4

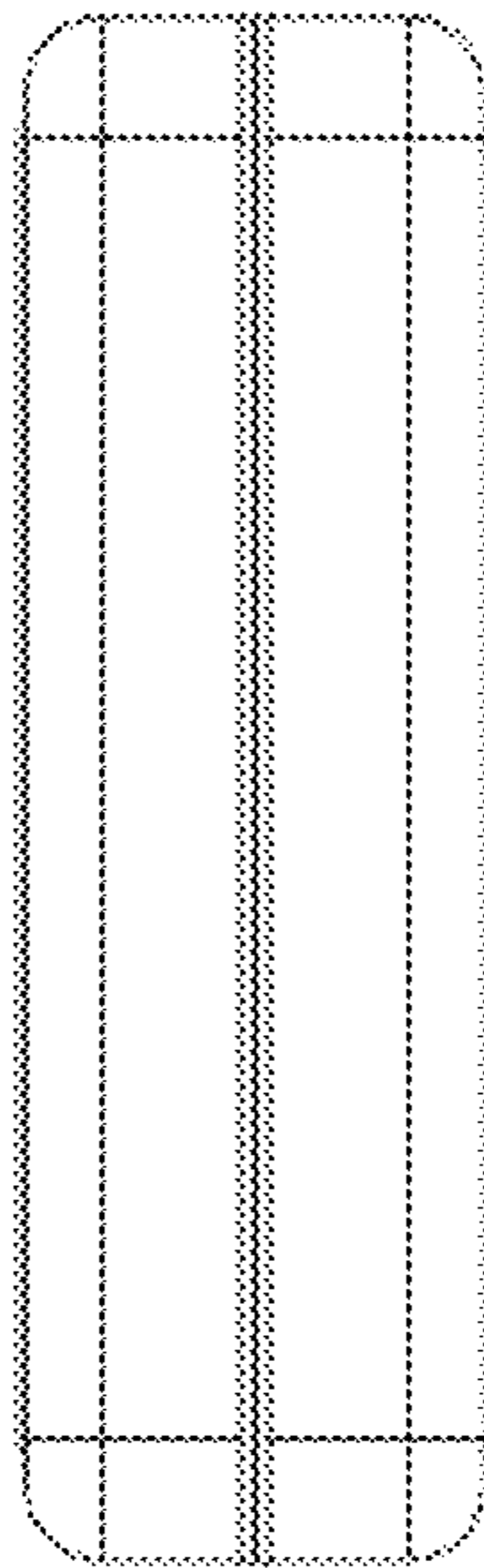

1.5

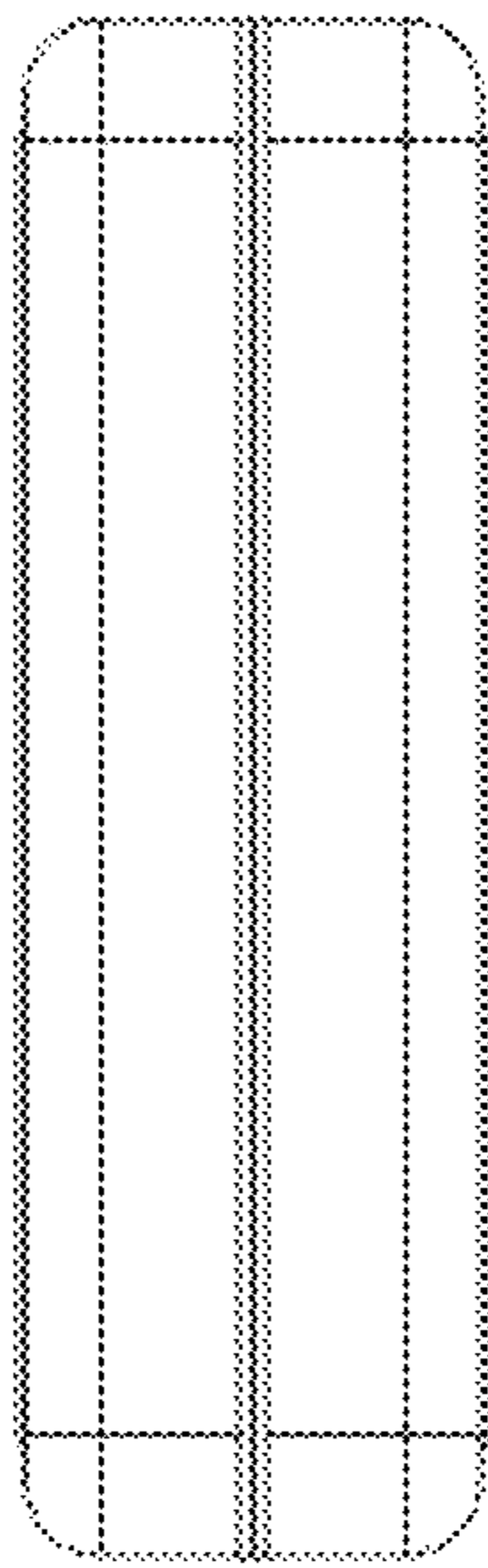

1.6

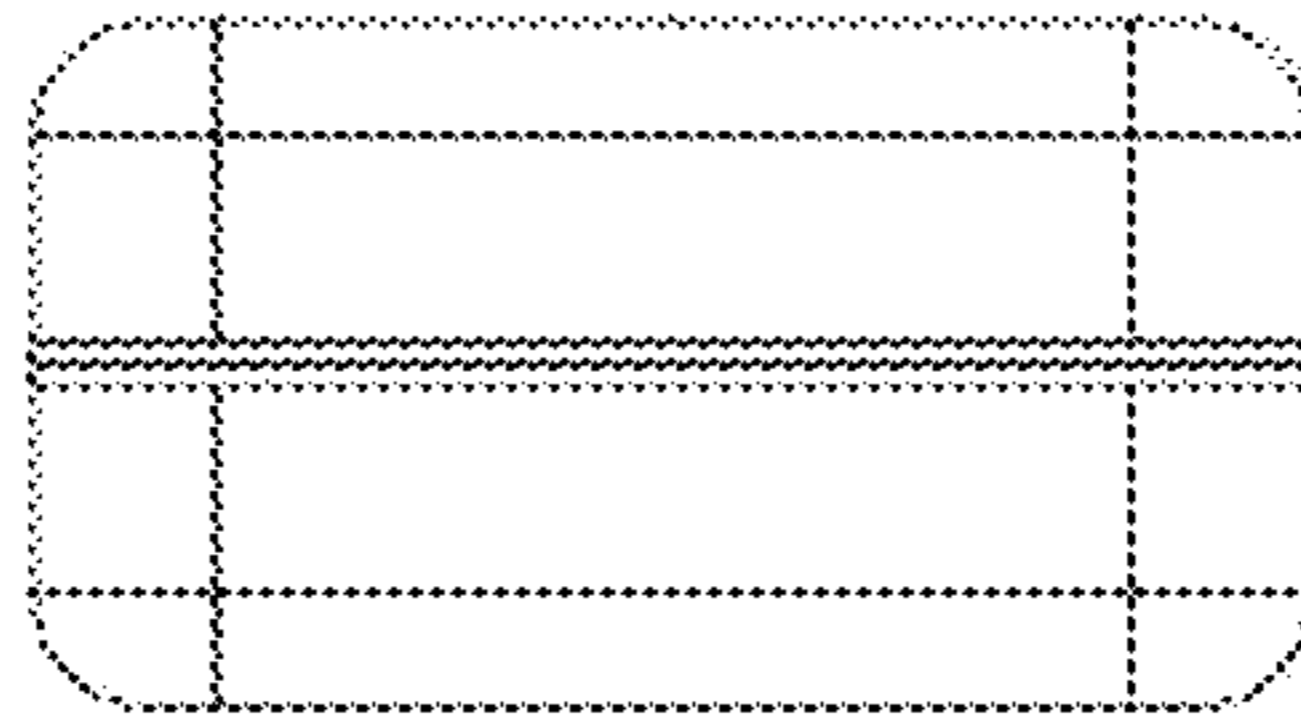

1.7

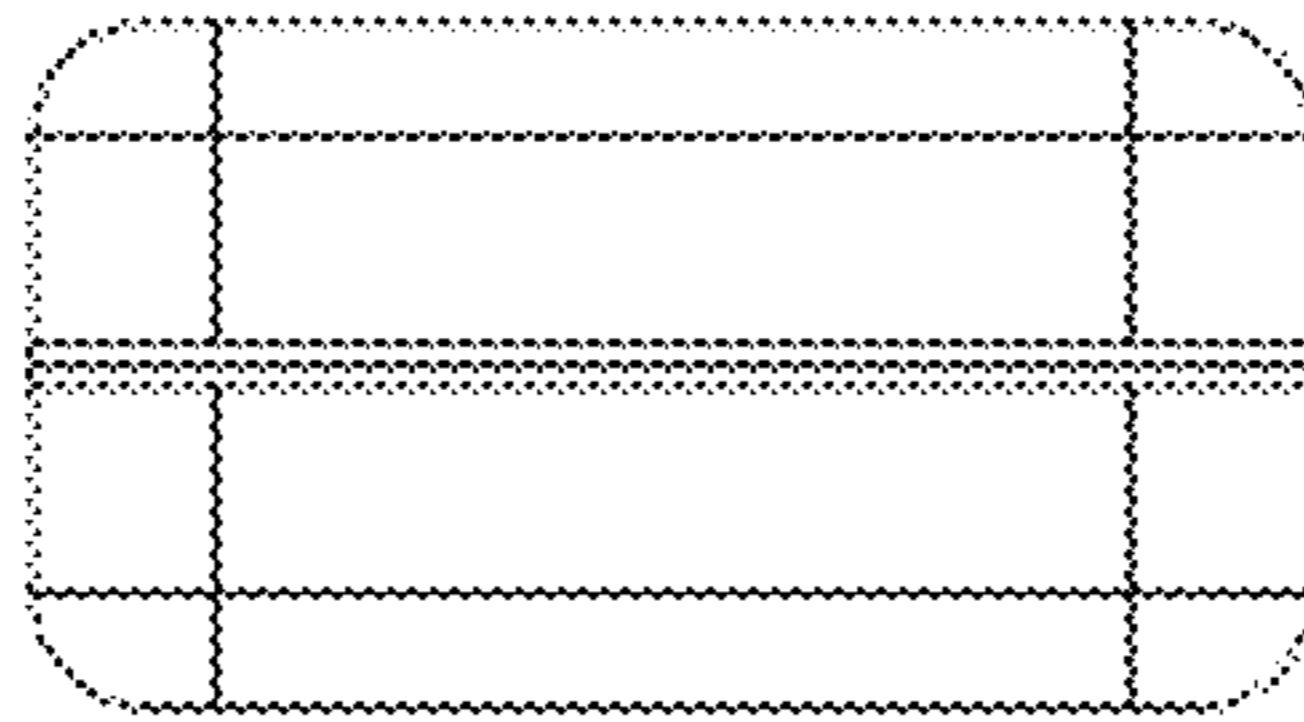

2.1

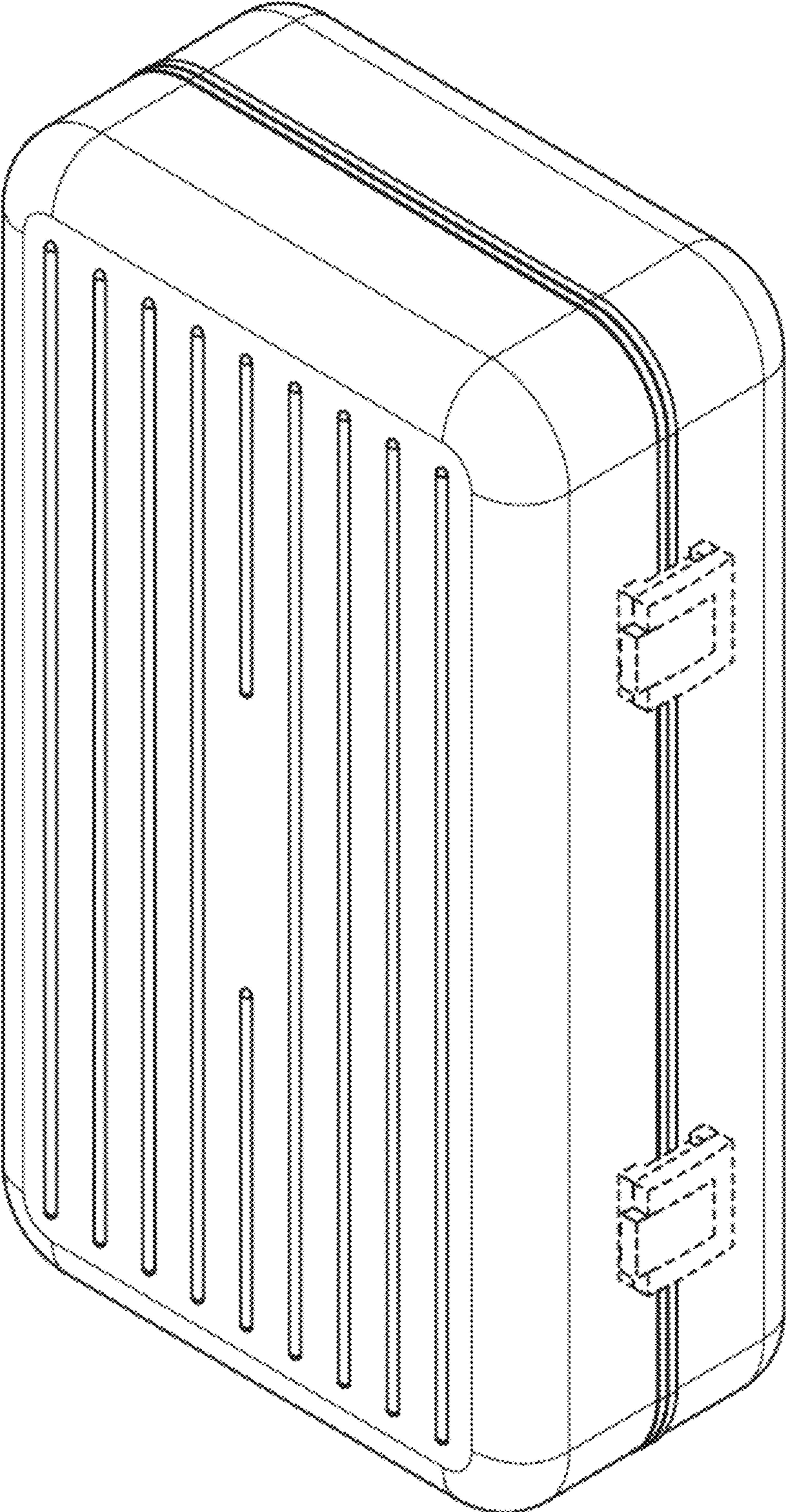

2.2

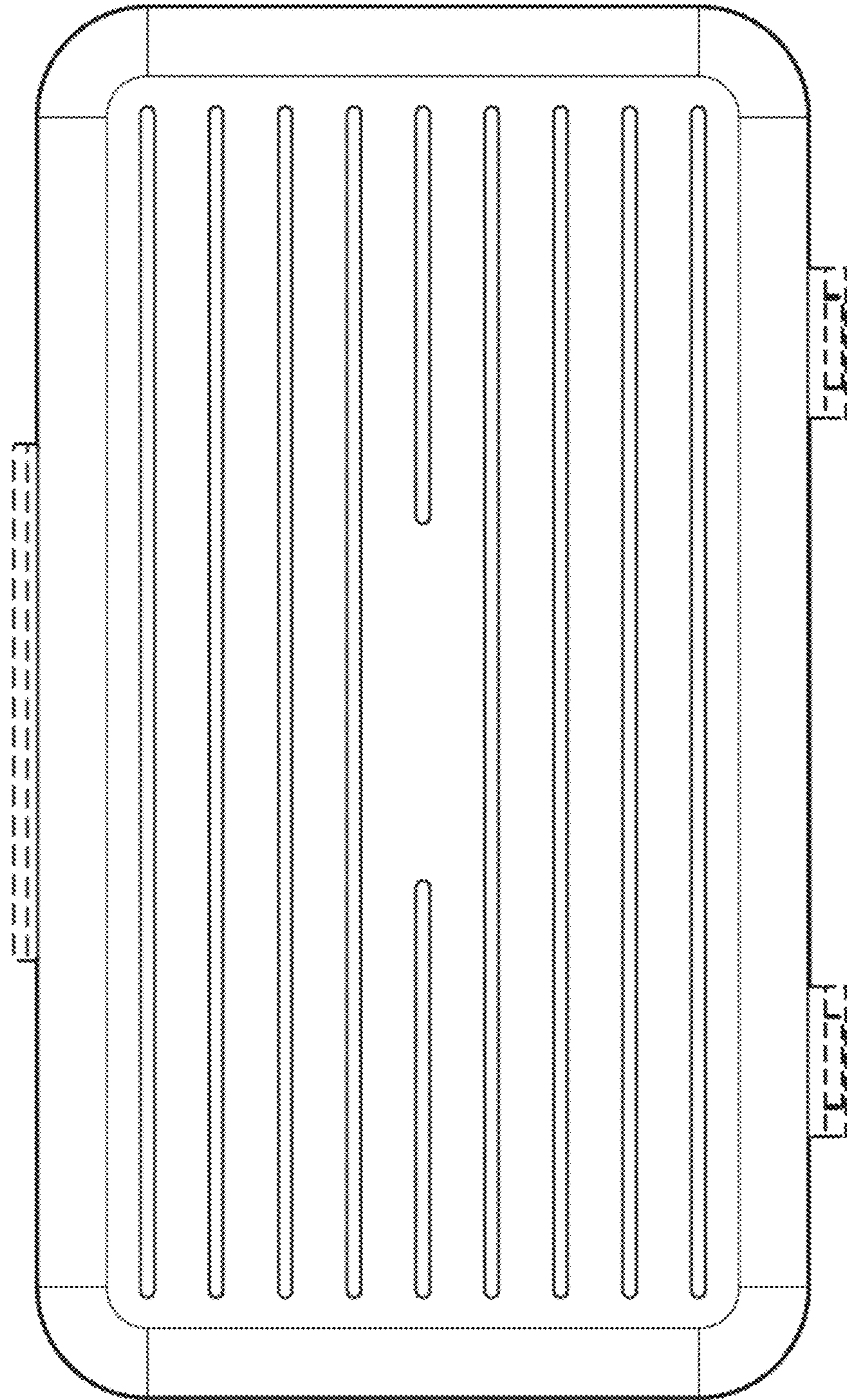

2.3

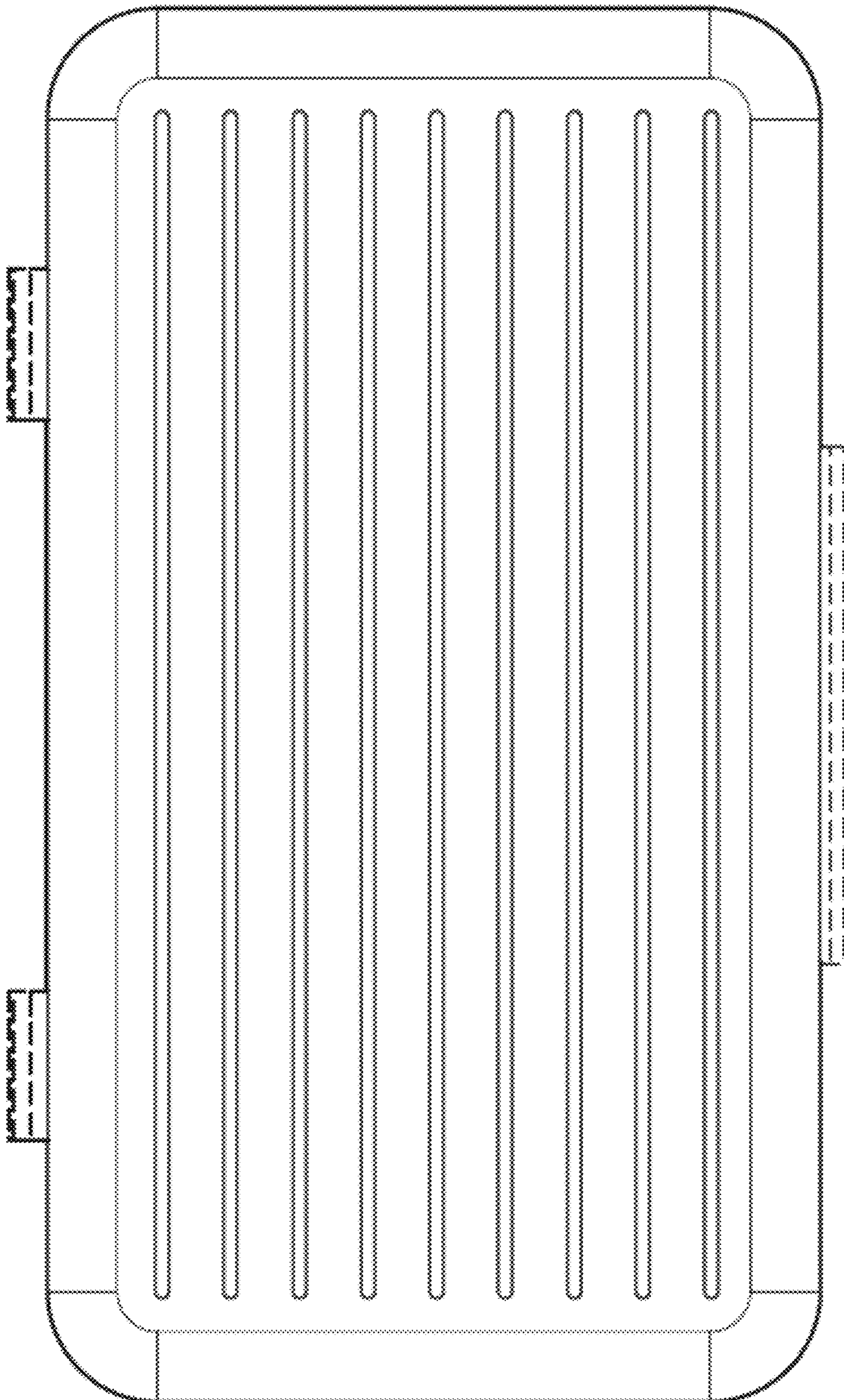

2.4

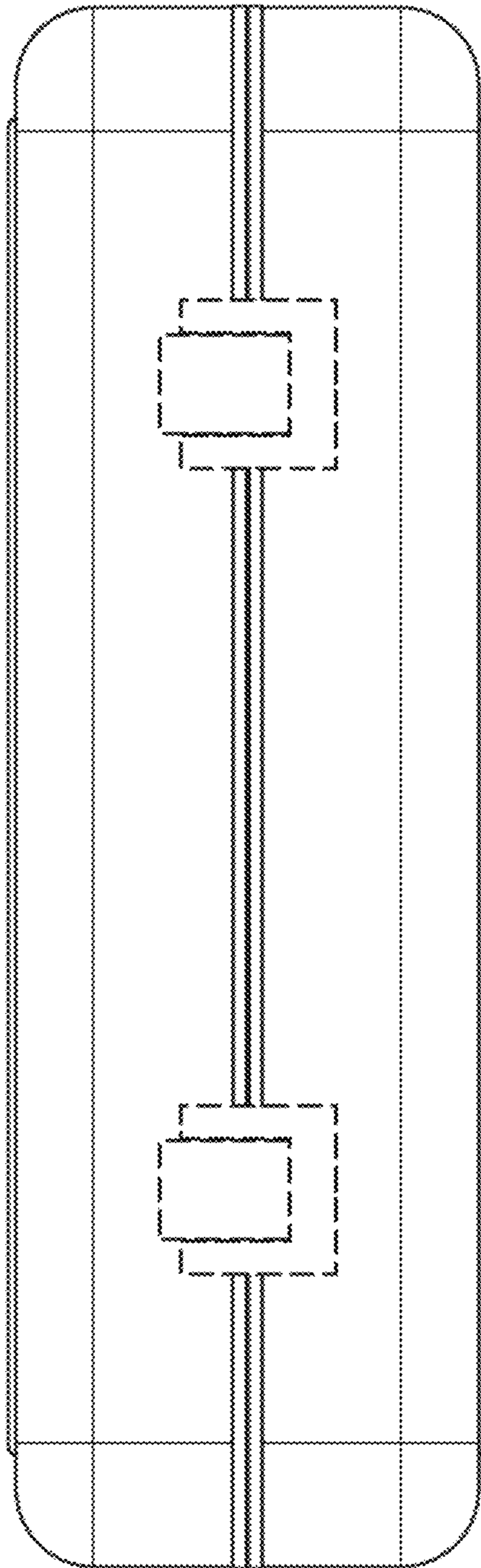

2.5

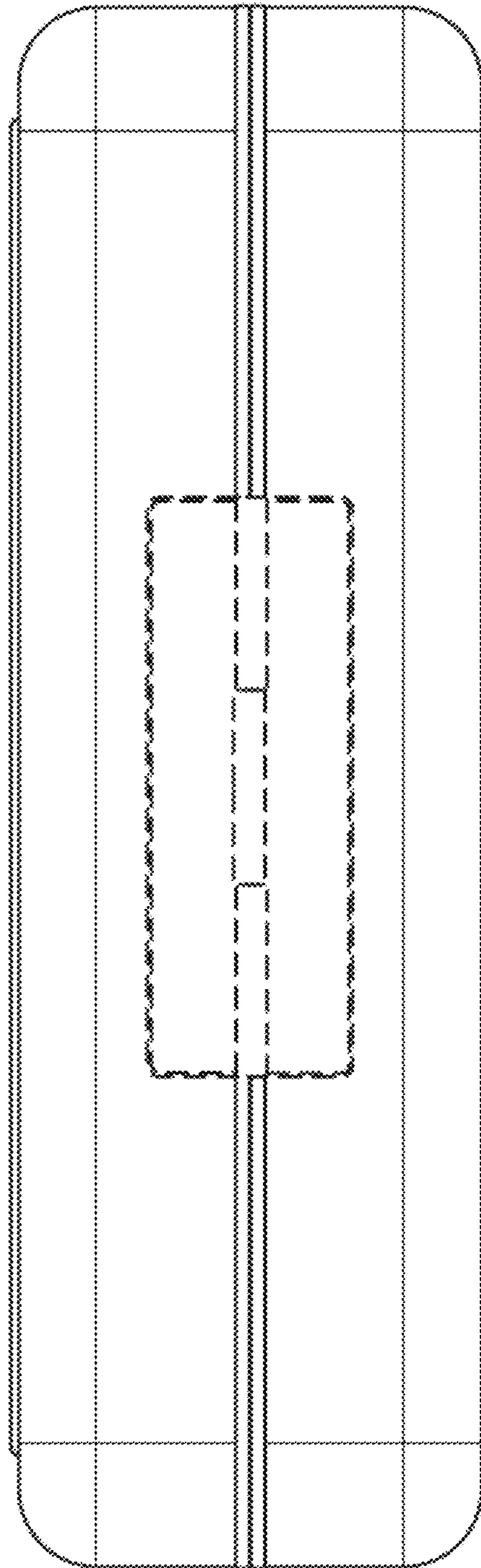

2.6

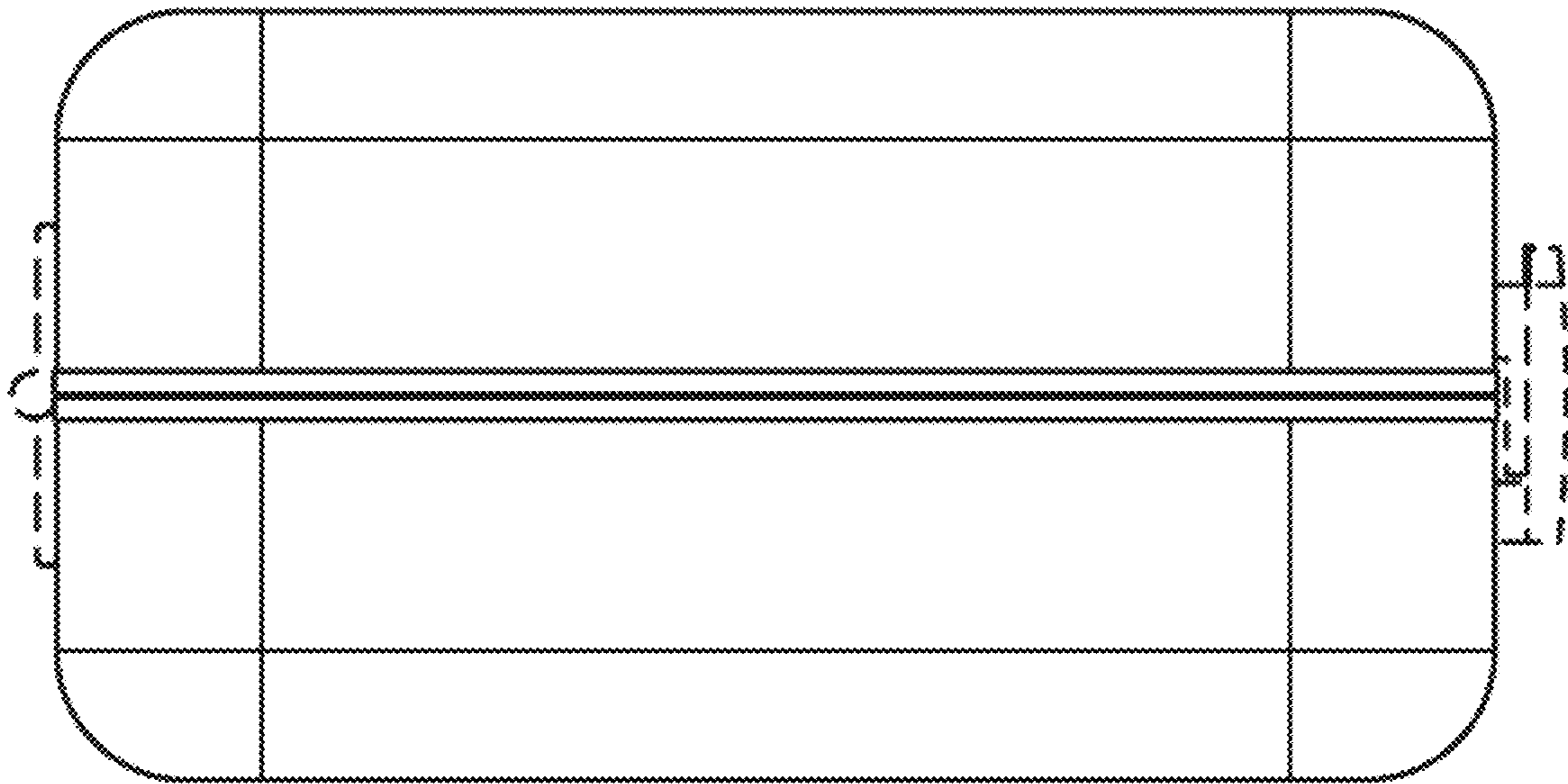

2.7

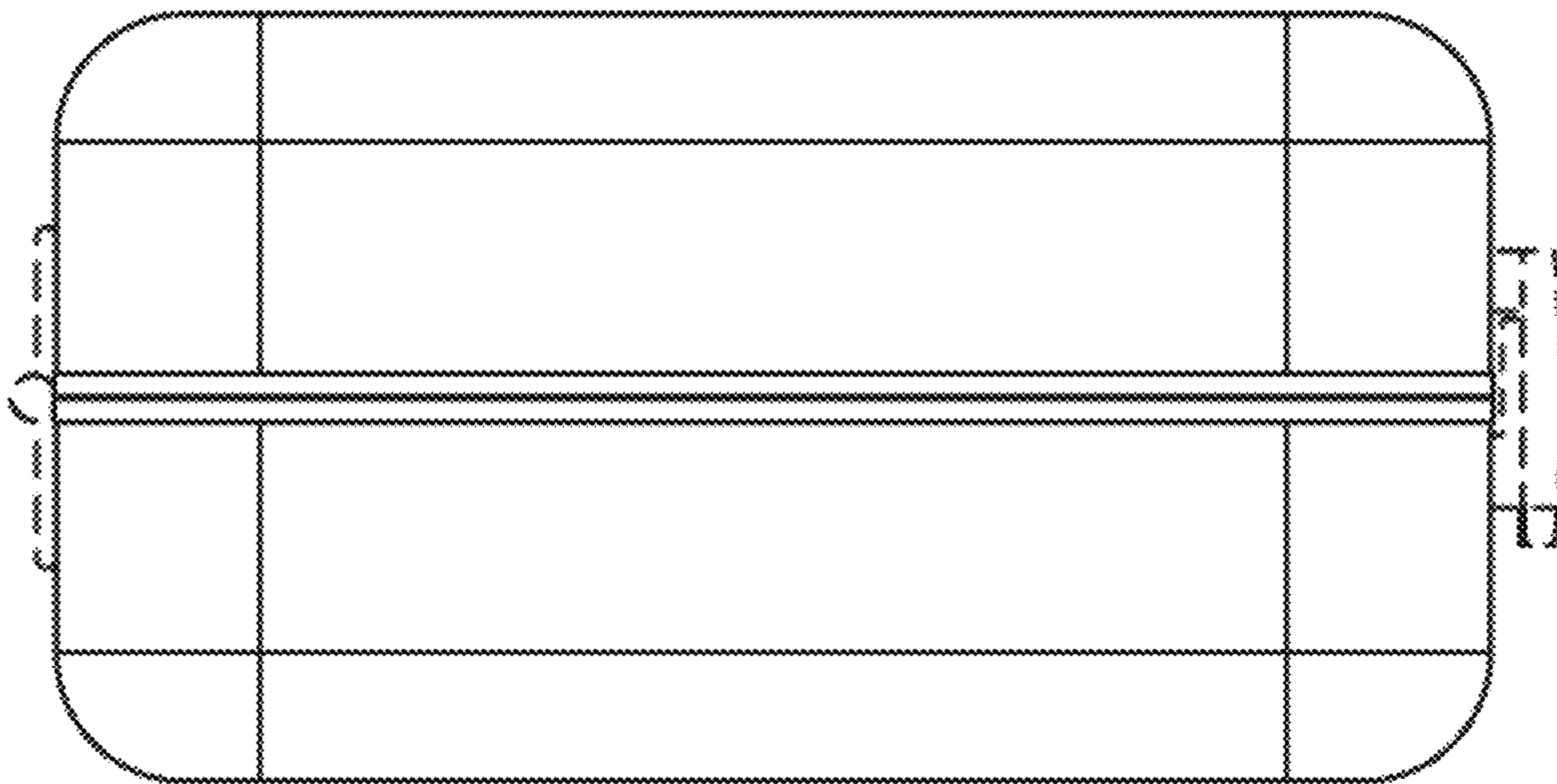

3.1

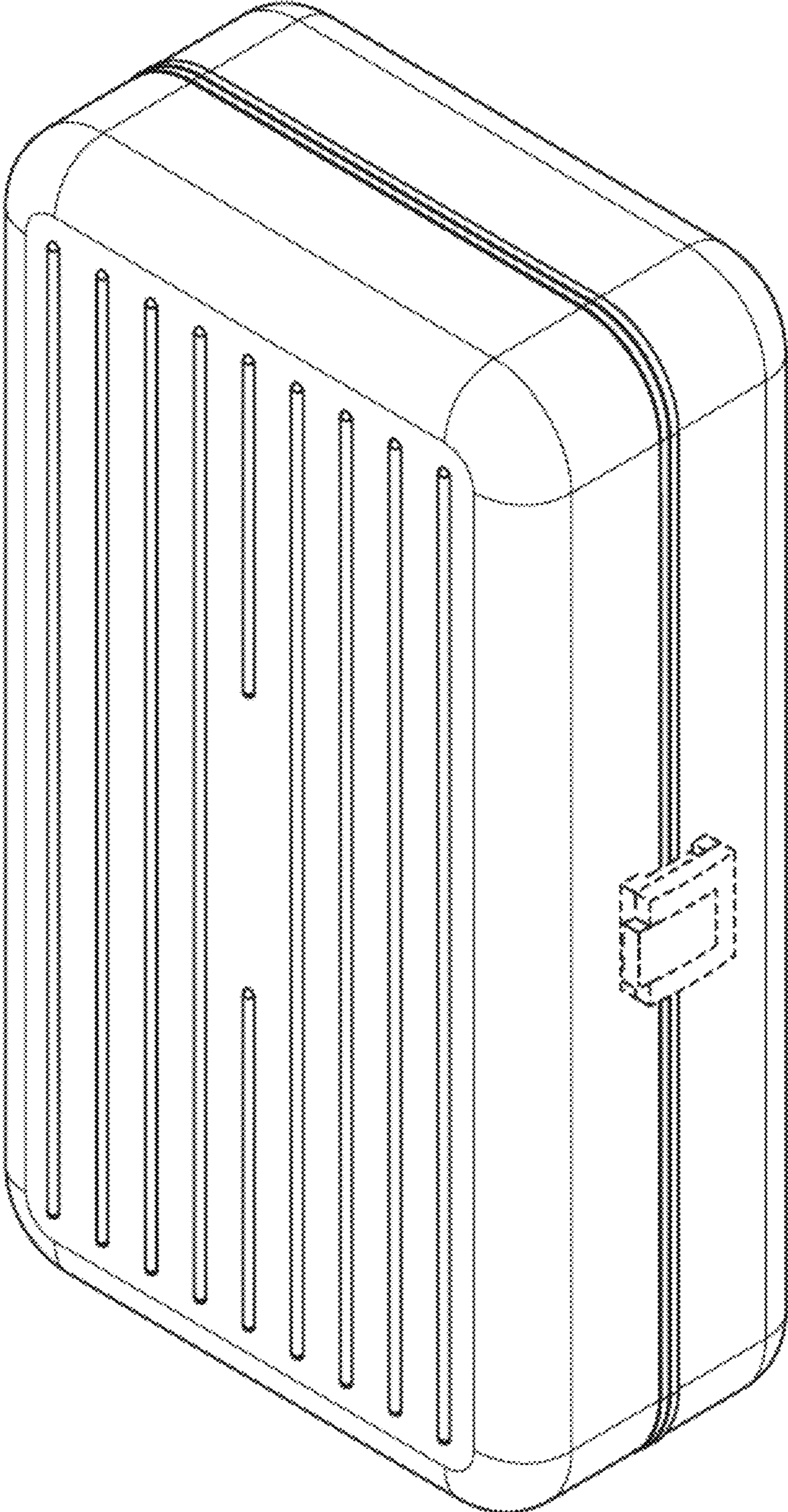

3.2

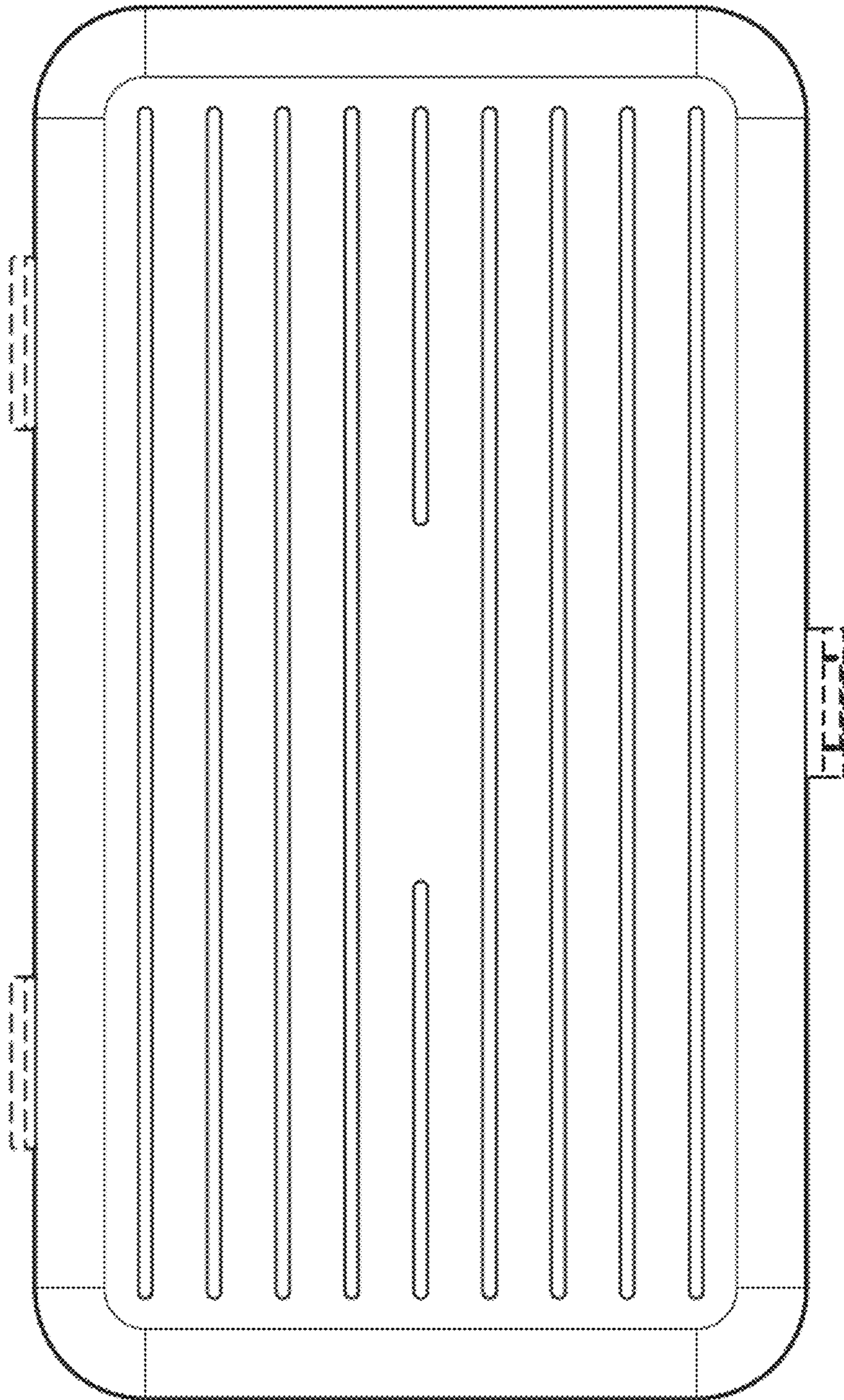

3.3

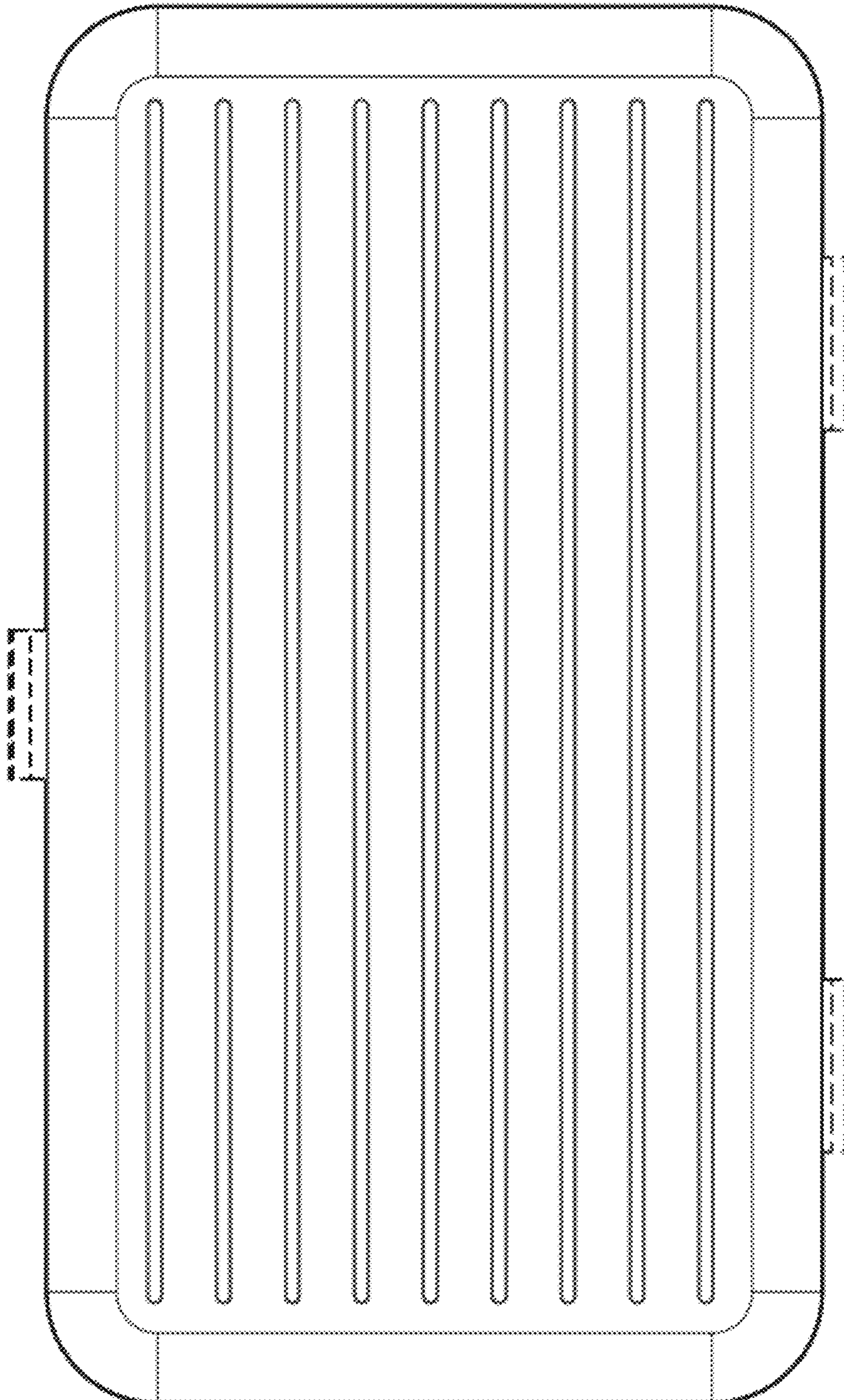

3.4

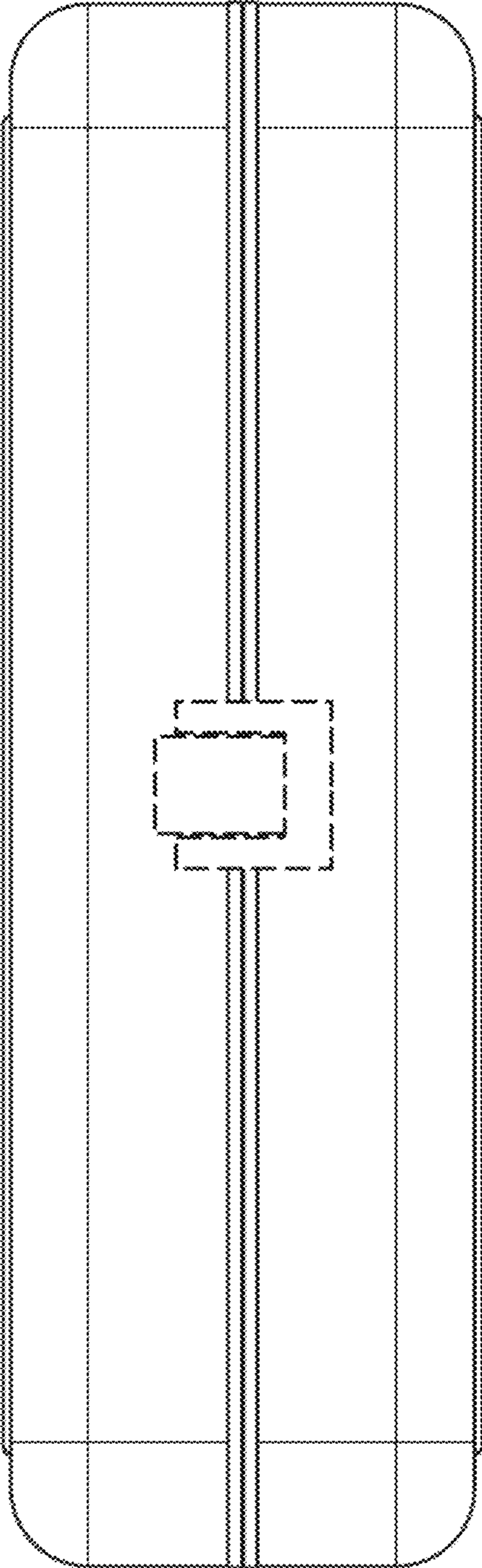

3.5

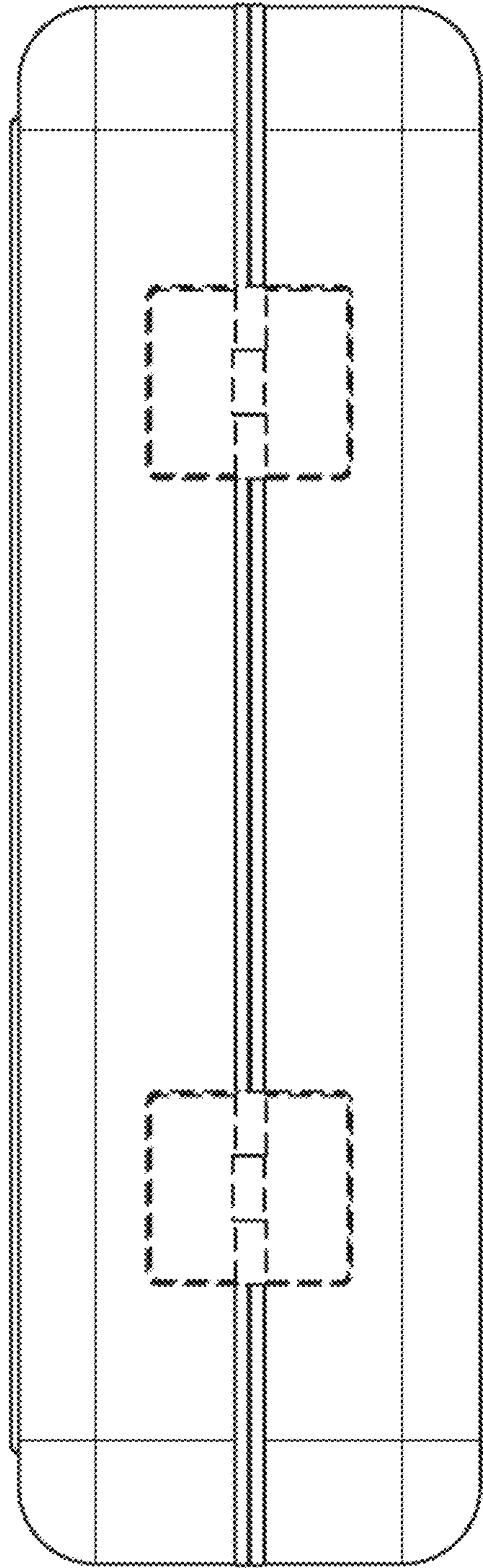

3.6

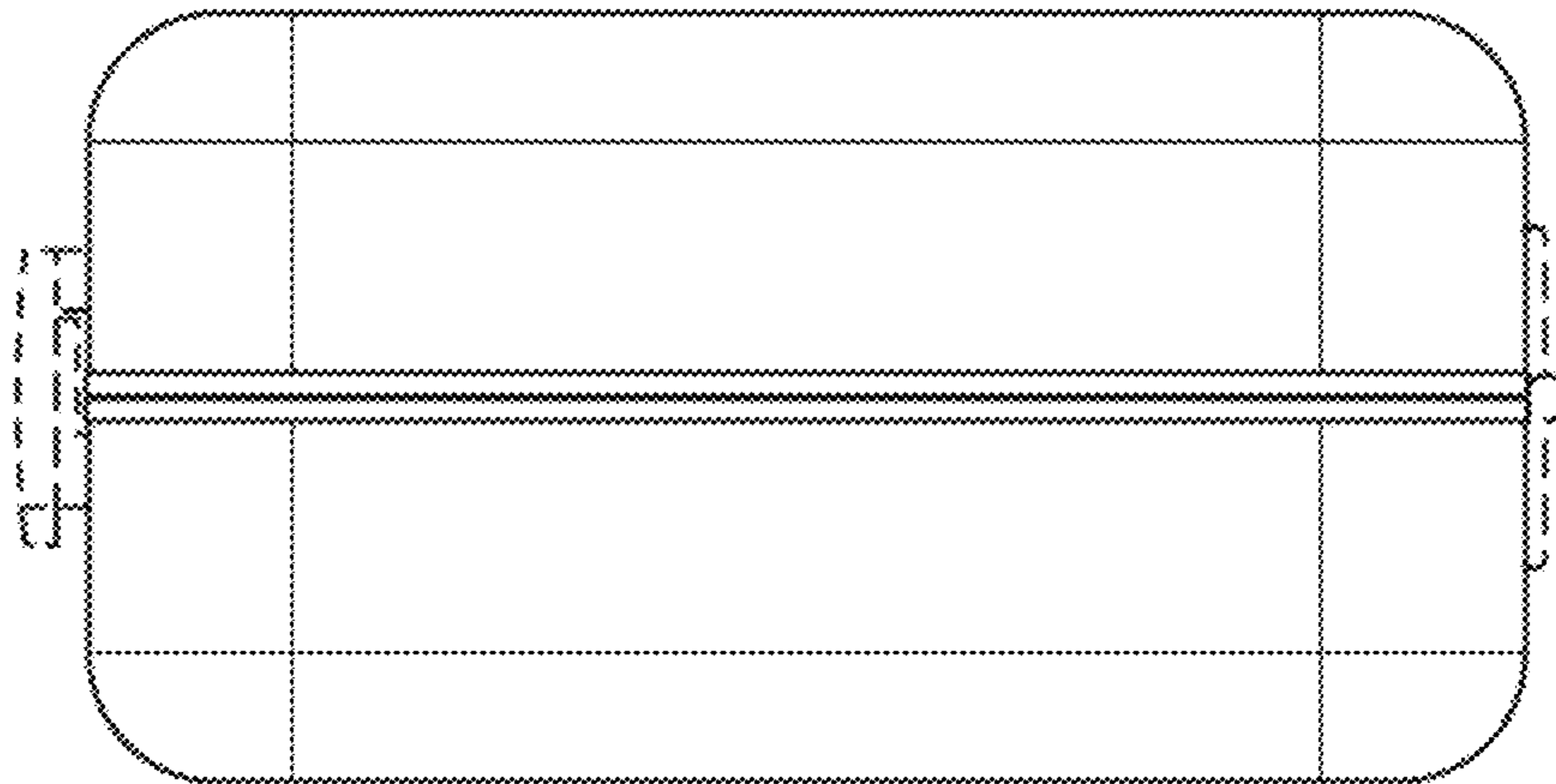

3.7

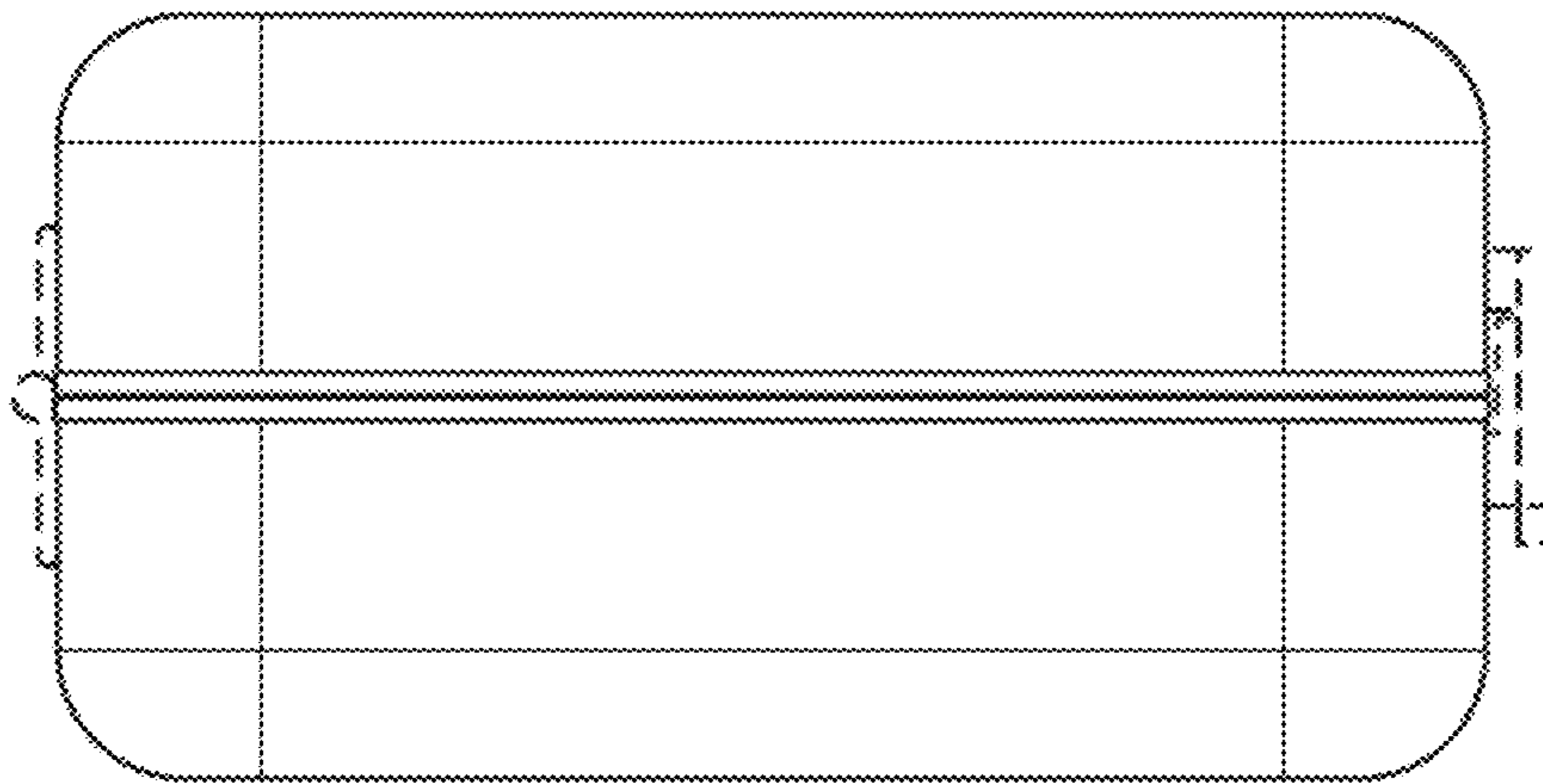

4.1

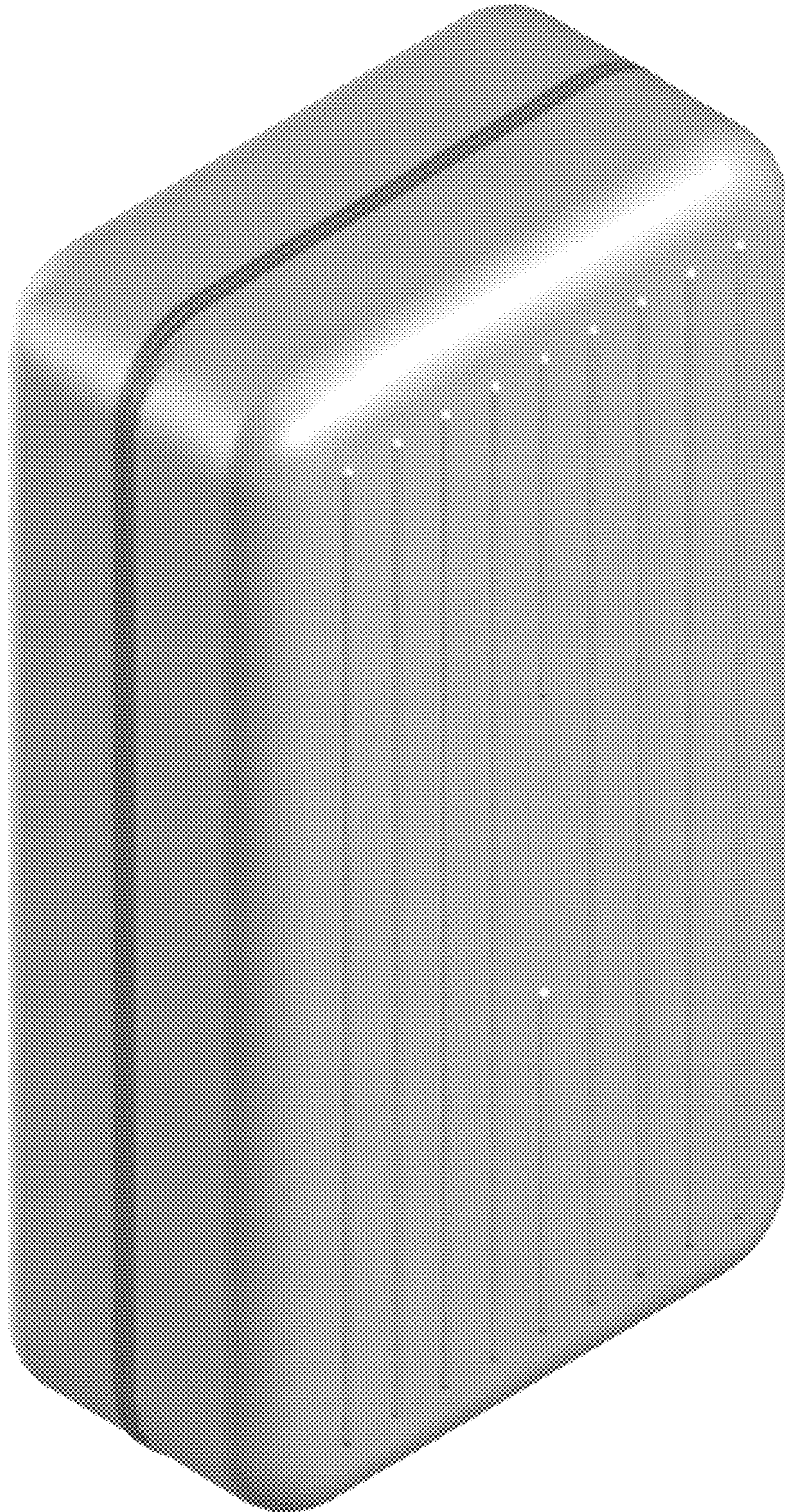

4.2

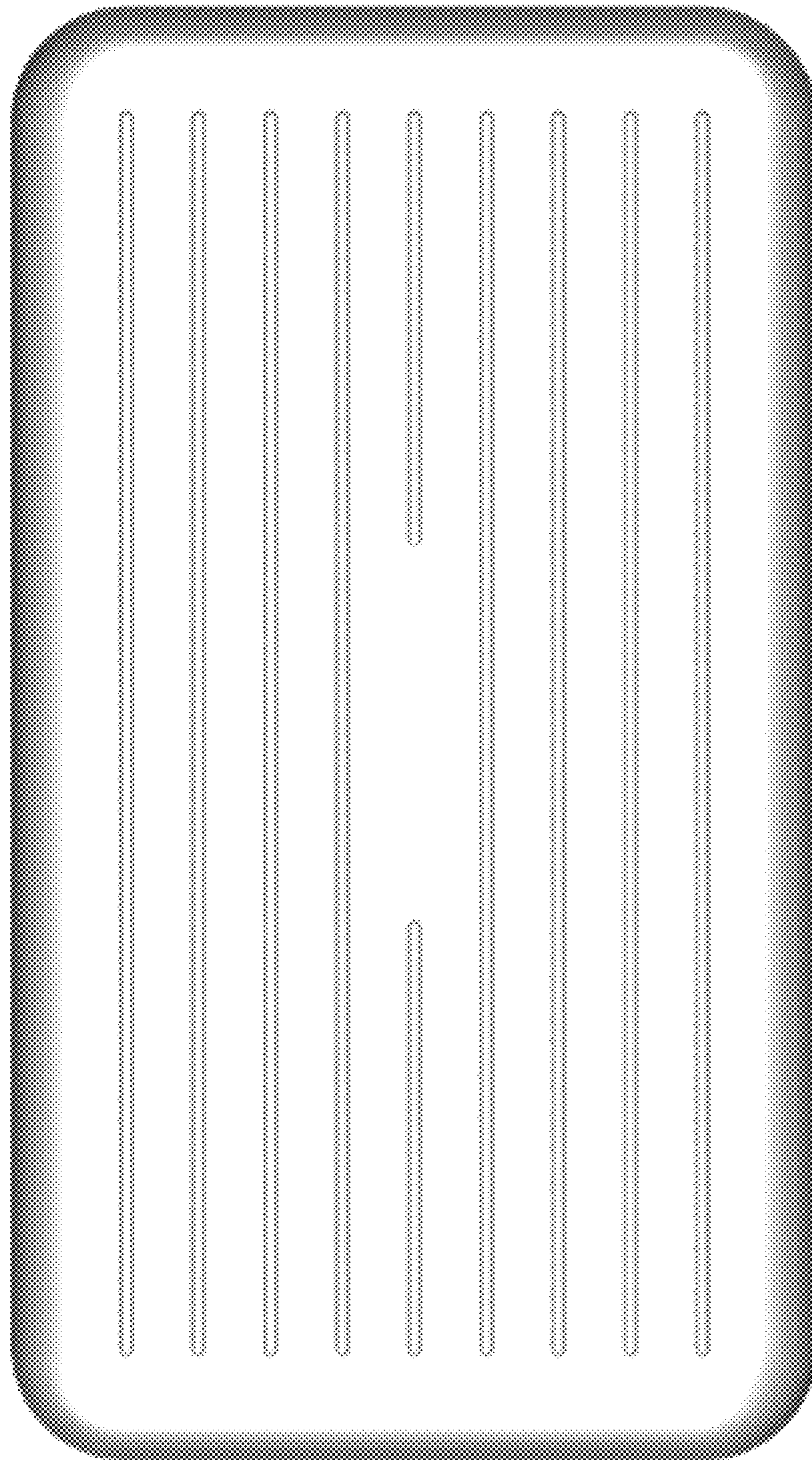

4.3

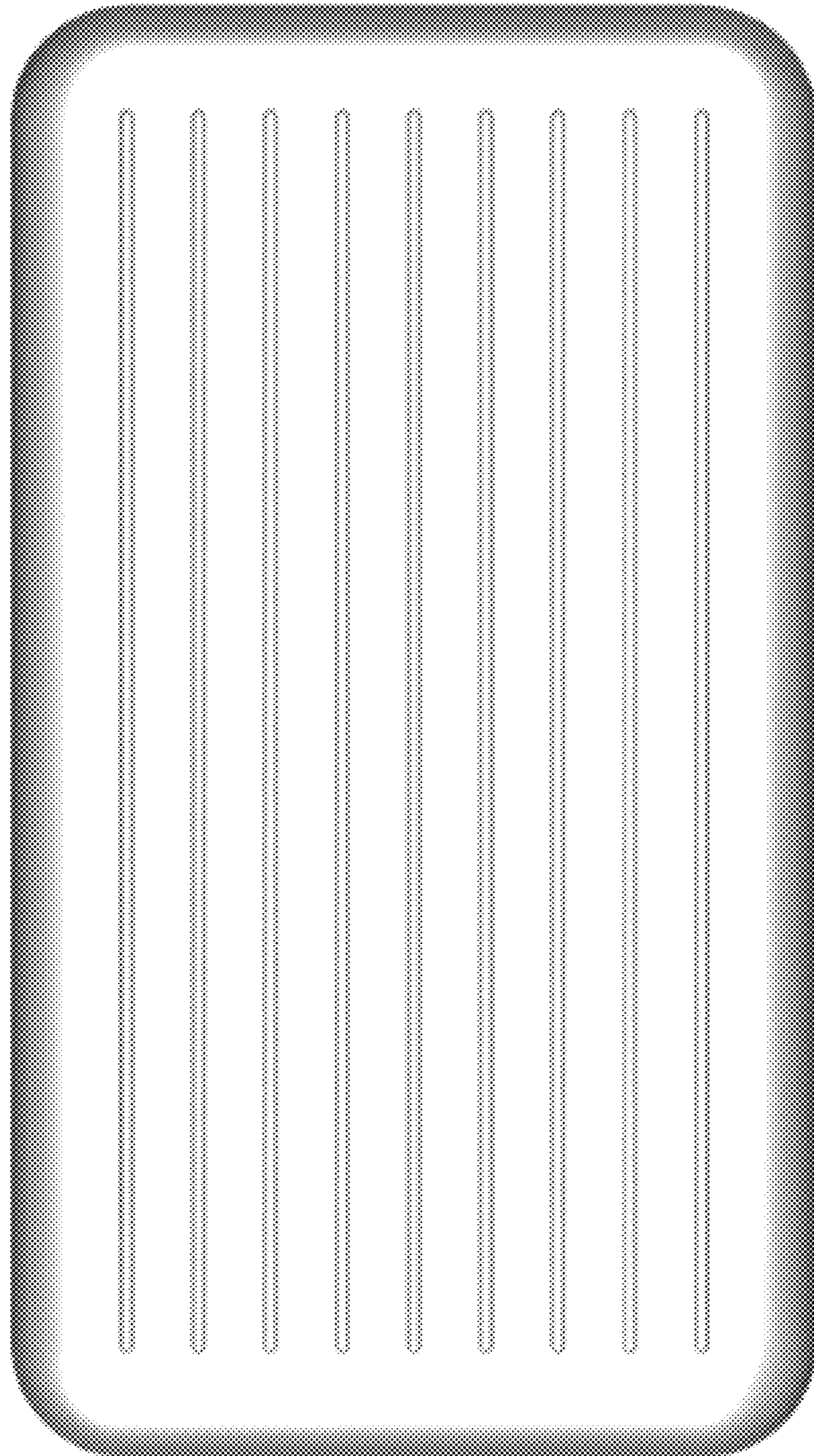

4.4

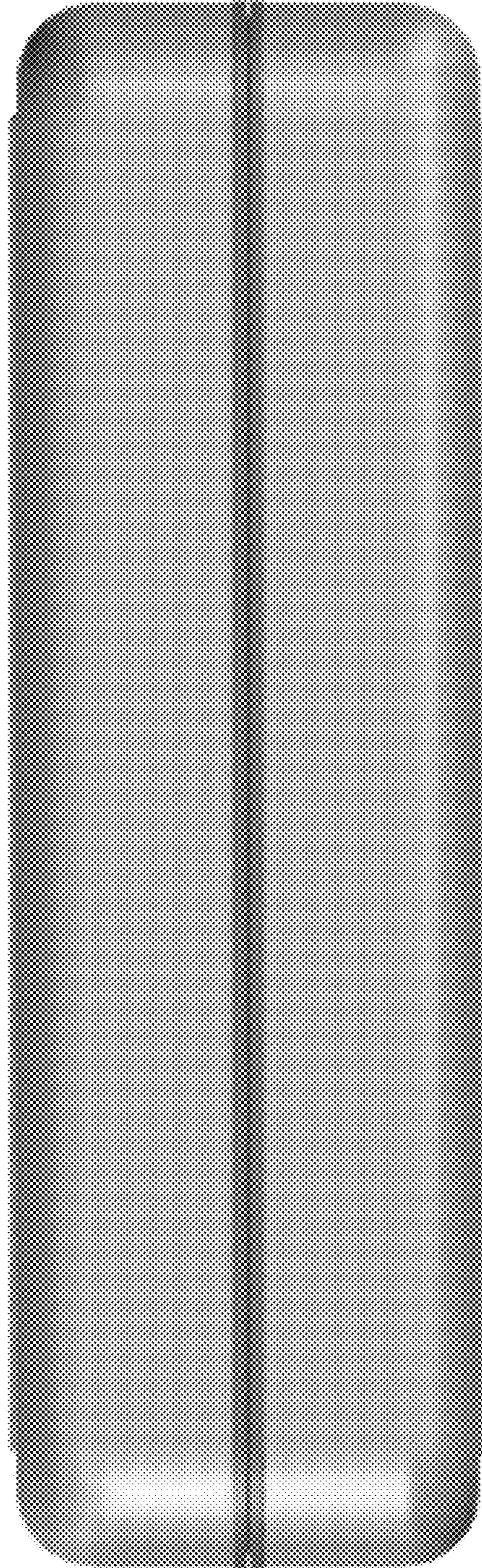

4.5

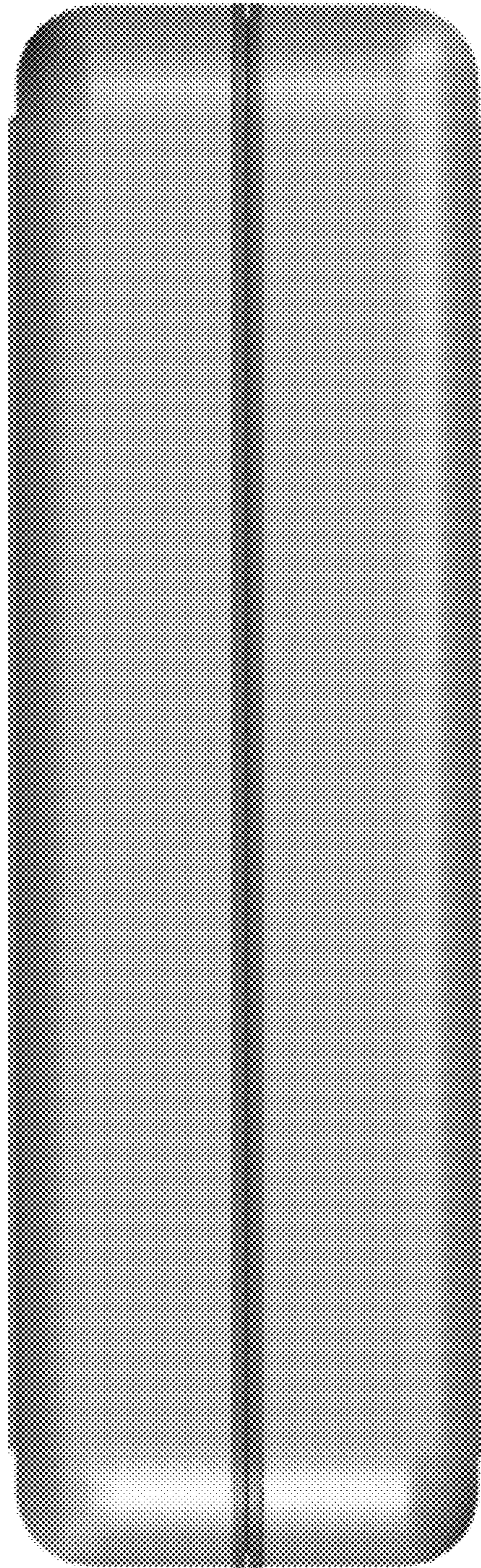

4.6

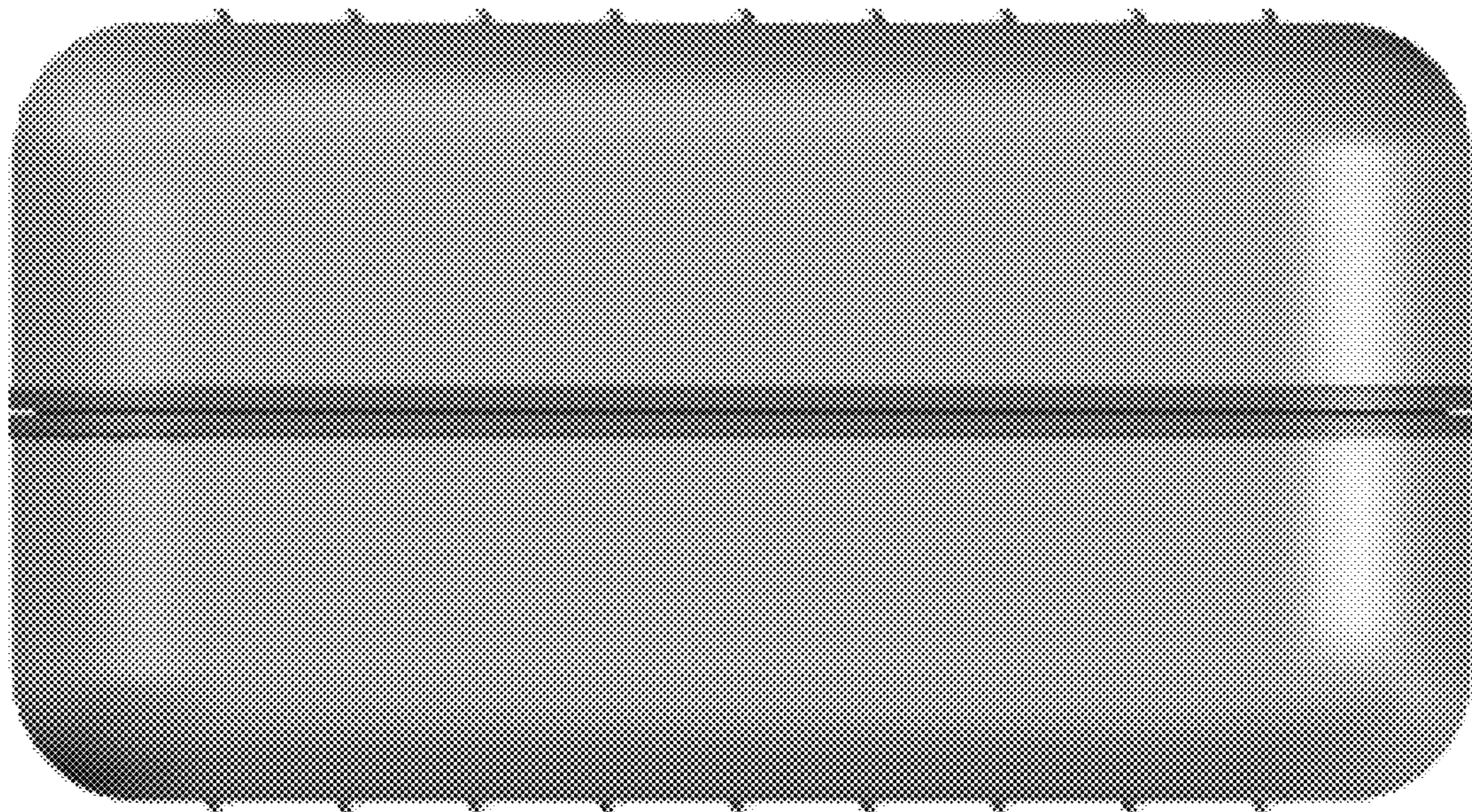

4.7

