



US00D927500S

(12) **United States Design Patent** (10) **Patent No.:** **US D927,500 S**
Wengreen et al. (45) **Date of Patent:** **** Aug. 10, 2021**

(54) **MOUNT FOR ELECTRONIC DEVICES**
(71) Applicant: **Innovelis, Inc.**, Sammamish, WA (US)
(72) Inventors: **Eric John Wengreen**, Sammamish, WA (US); **Ian Jacob van de Kamp**, Seattle, WA (US)
(73) Assignee: **Innovelis, Inc.**, Sammamish, WA (US)
(**) Term: **15 Years**
(21) Appl. No.: **29/757,272**
(22) Filed: **Nov. 4, 2020**

(56) **References Cited**
U.S. PATENT DOCUMENTS
D614,427 S 4/2010 Nejad
D627,340 S * 11/2010 Lan D14/253
D643,659 S 8/2011 Choi
D662,502 S * 6/2012 Wesolek D14/434
D716,580 S 11/2014 Wengreen
D727,143 S 4/2015 Gomez
D729,544 S 5/2015 Wengreen
D749,597 S * 2/2016 Wengreen D14/447
D751,563 S * 3/2016 Wengreen D14/447
D804,845 S 12/2017 Cockburn
D808,188 S 1/2018 Cockburn
(Continued)

Primary Examiner — Angela J Lee

Related U.S. Application Data

(63) Continuation of application No. 29/757,270, filed on Nov. 4, 2020, and a continuation-in-part of application No. 29/730,463, filed on Apr. 3, 2020, now Pat. No. Des. 914,691, and a continuation-in-part of application No. 29/728,620, filed on Mar. 19, 2020, and a continuation-in-part of application No. 29/728,623, filed on Mar. 19, 2020, now Pat. No. Des. 914,690, and a continuation-in-part of application No. 29/709,809, filed on Oct. 17, 2019, now Pat. No. Des. 905,069, and a continuation-in-part of application No. 29/690,707, filed on May 9, 2019, now Pat. No. Des. 905,068, and a continuation-in-part of application No. 29/690,706, filed on May 9, 2019, now Pat. No. Des. 905,067.

(51) **LOC (13) Cl.** **08-07**
(52) **U.S. Cl.**
USPC **D14/447**

(58) **Field of Classification Search**
USPC D14/447, 432, 434, 439, 440, 451, 452, D14/457, 239, 253; D8/363, 373, 380; D6/406.3, 406.4, 406.5, 406.6; D12/415
CPC A47B 21/04; A47B 2097/006; A47B 2097/005; A47B 2023/049; A45C 2011/002; A45C 2011/003; F16M 2200/00; F16M 13/00

See application file for complete search history.

(57) **CLAIM**

The ornamental design for a mount for electronic devices, as shown and described.

DESCRIPTION

FIG. 1 is a front, first side, and top perspective view of a mount for electronic devices embodying the new design; FIG. 2 is a back, second side, and bottom perspective view thereof; FIG. 3 is a top, back, and first side perspective view thereof; FIG. 4 is a front view thereof; FIG. 5 is a back view thereof; FIG. 6 is a second side view thereof; FIG. 7 is a first side view thereof; FIG. 8 is a bottom view thereof; and, FIG. 9 is a top view thereof.

The uniform repeating broken lines depict portions of a mount for electronic devices in which the claimed design is embodied and form no part of the claimed design.

1 Claim, 9 Drawing Sheets

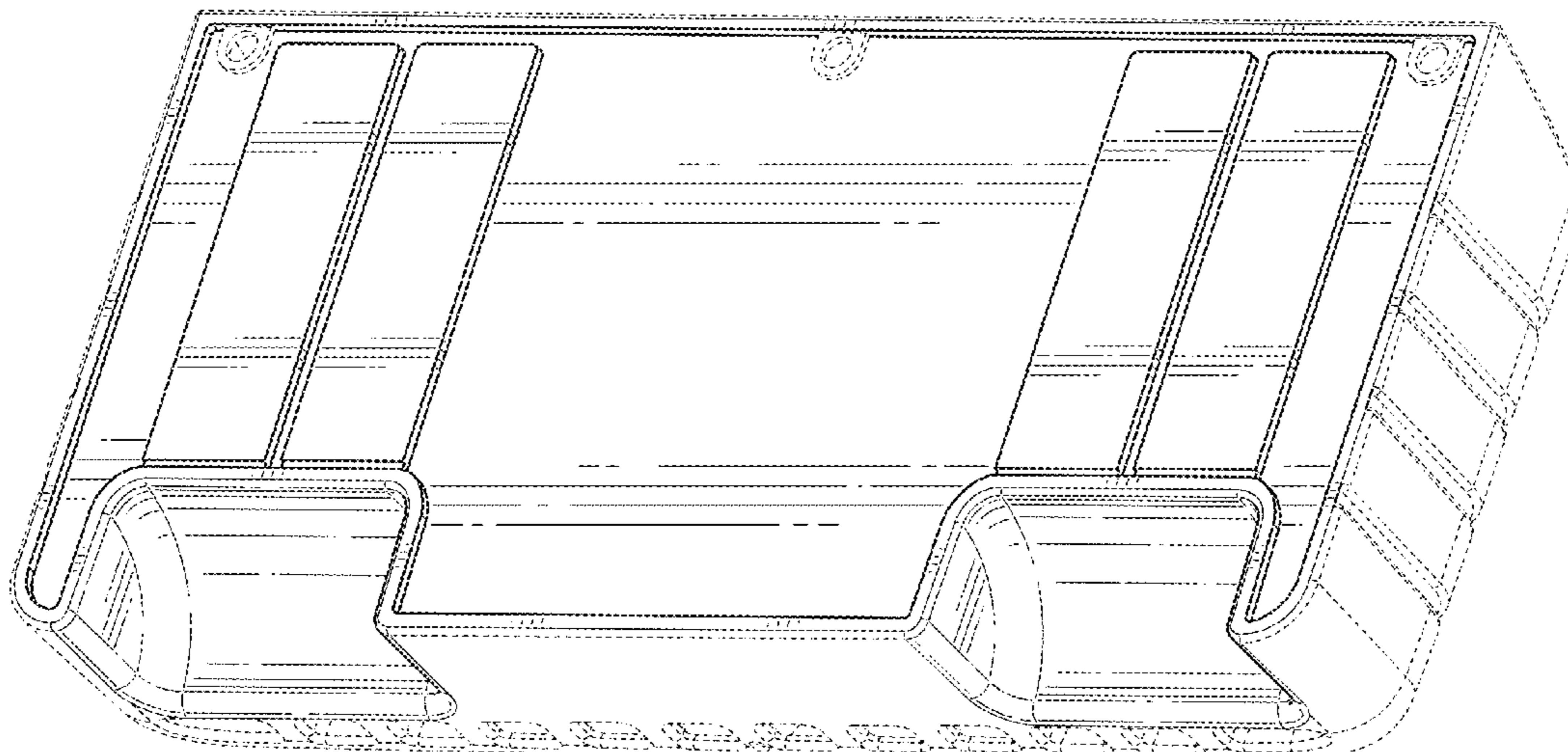

(56)

References Cited

U.S. PATENT DOCUMENTS

D824,399	S	*	7/2018	Wengreen	D14/447
D832,858	S		11/2018	Wengreen		
D845,027	S	*	4/2019	Corona	D6/553
D845,028	S		4/2019	Corona		
D845,310	S	*	4/2019	Wengreen	D14/447
D845,959	S	*	4/2019	Wengreen	D14/447
D877,137	S		3/2020	Engerman		
D883,755	S		5/2020	Nicholson		
D903,429	S		12/2020	Joseph		
D905,067	S	*	12/2020	Wengreen	D14/447
D905,068	S	*	12/2020	Wengreen	D14/447
D905,069	S	*	12/2020	Wengreen	D14/447
D914,690	S	*	3/2021	Wengreen	D14/447
D914,691	S	*	3/2021	Wengreen	D14/447

* cited by examiner

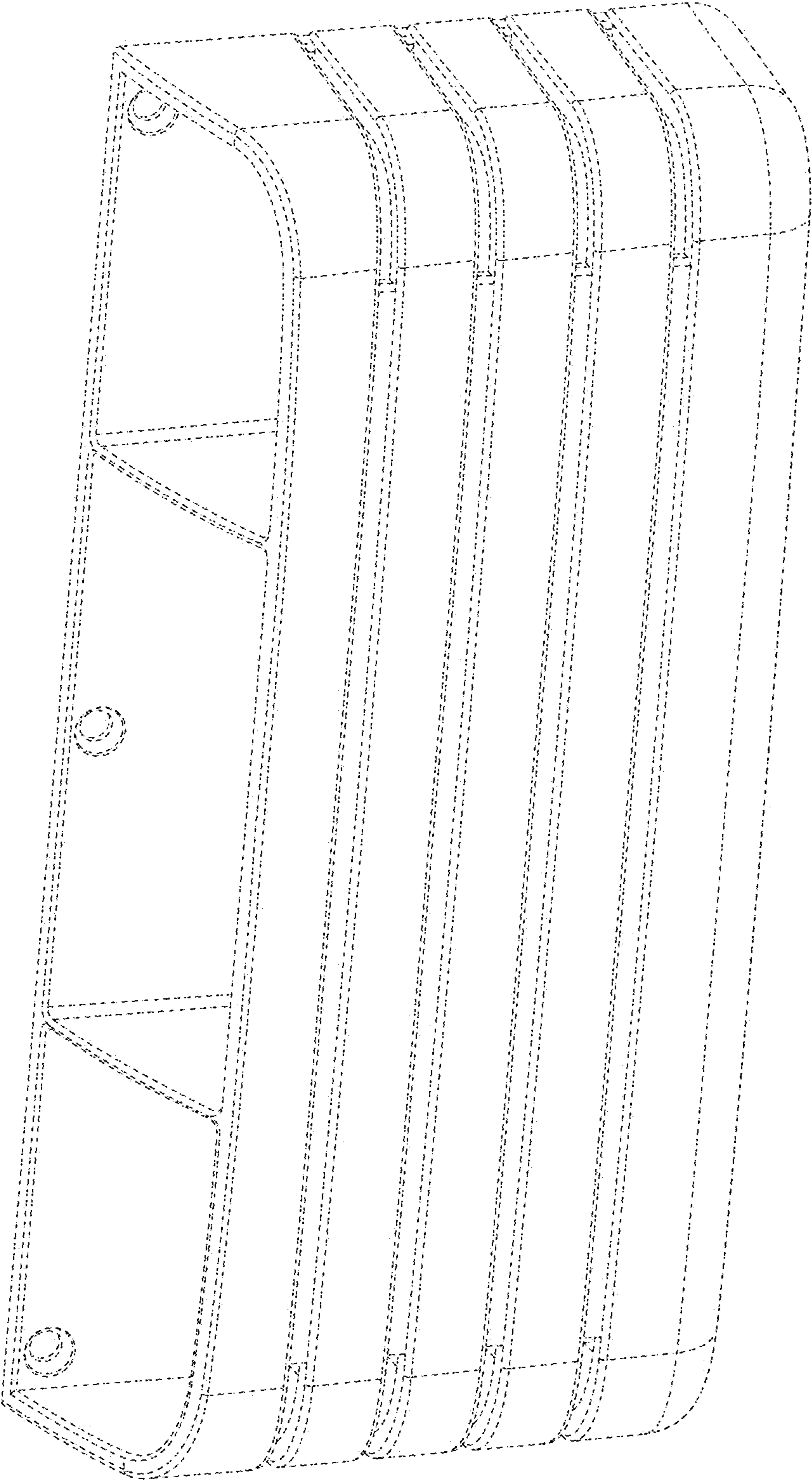

FIG. 1

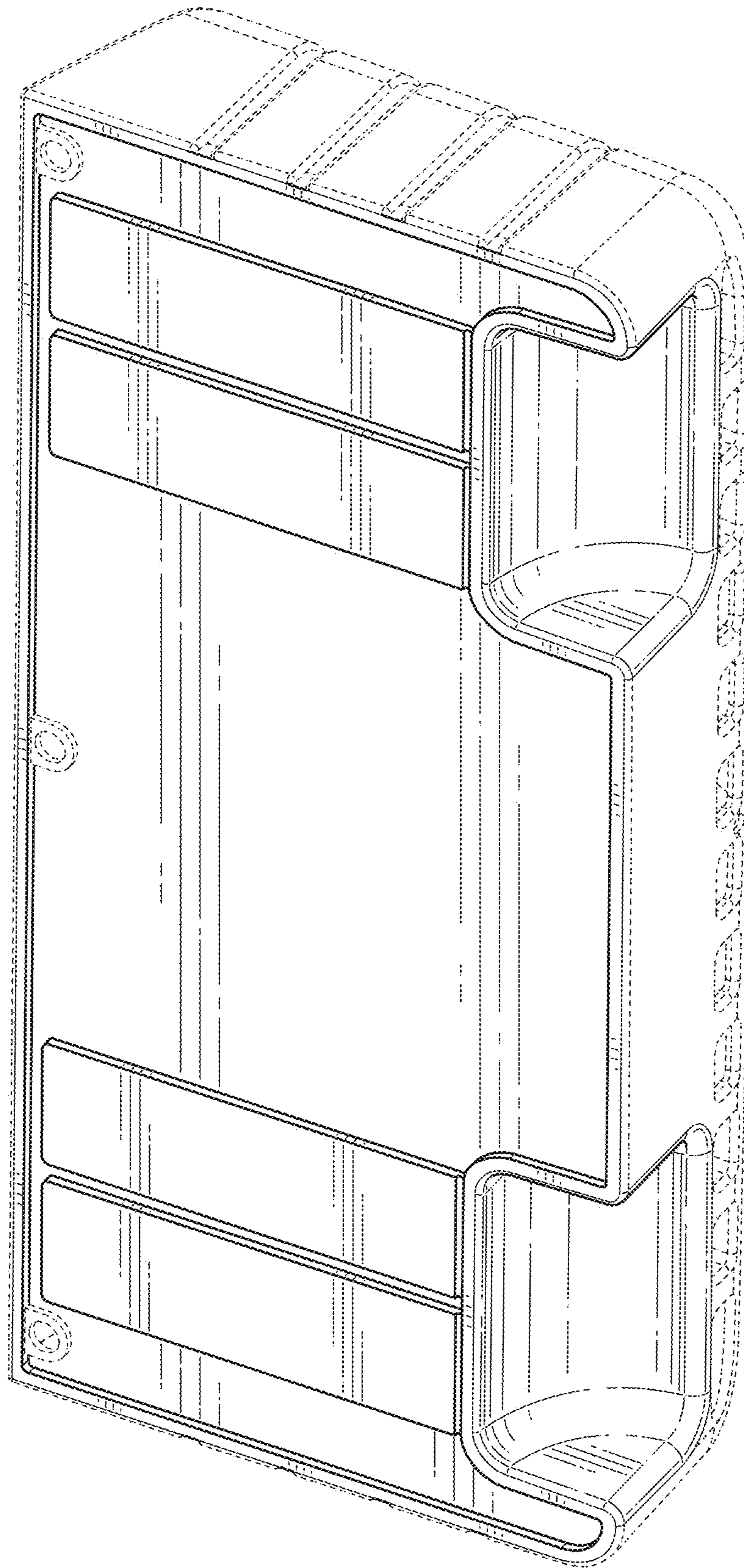

FIG. 2

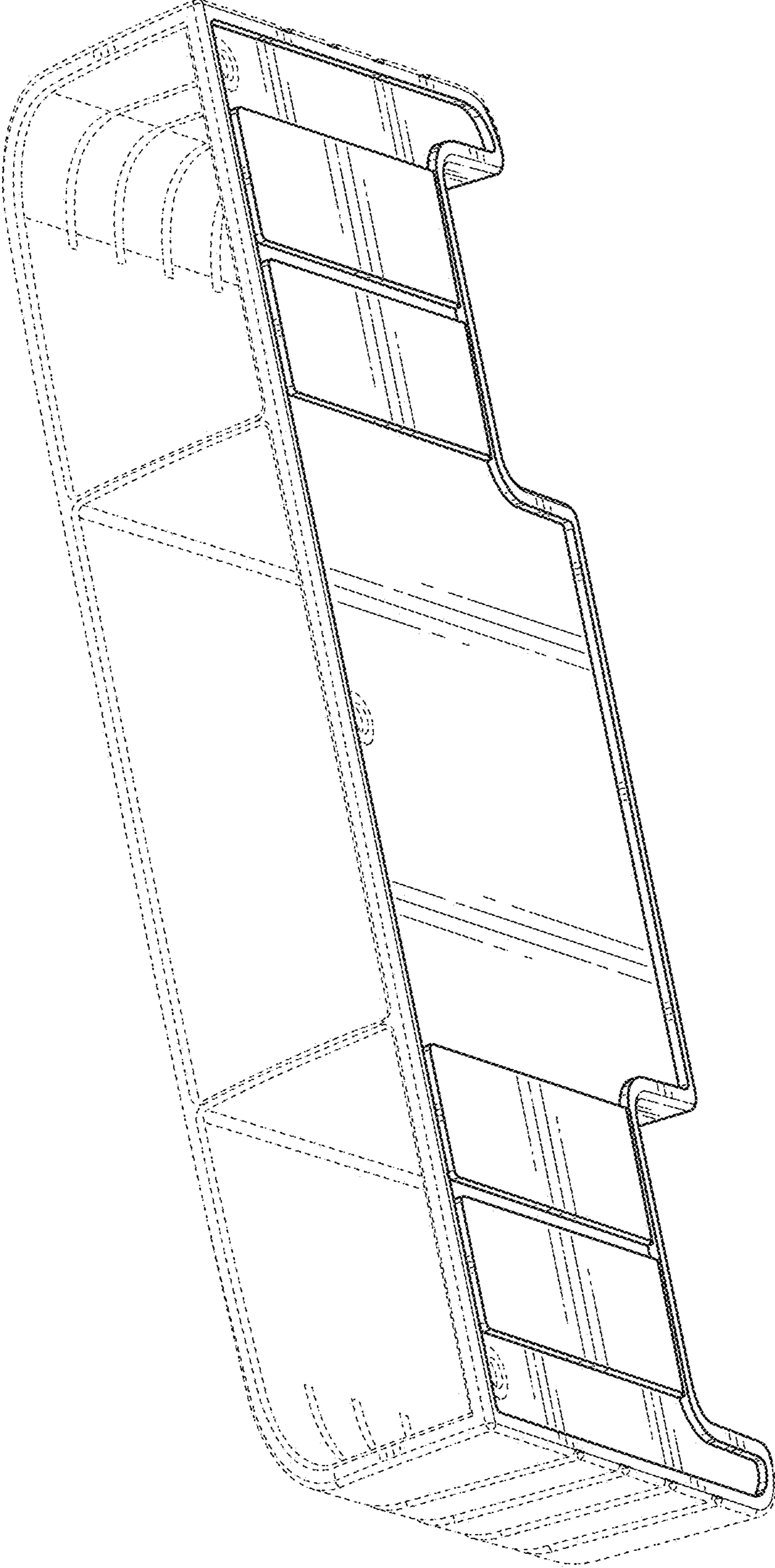

FIG. 3

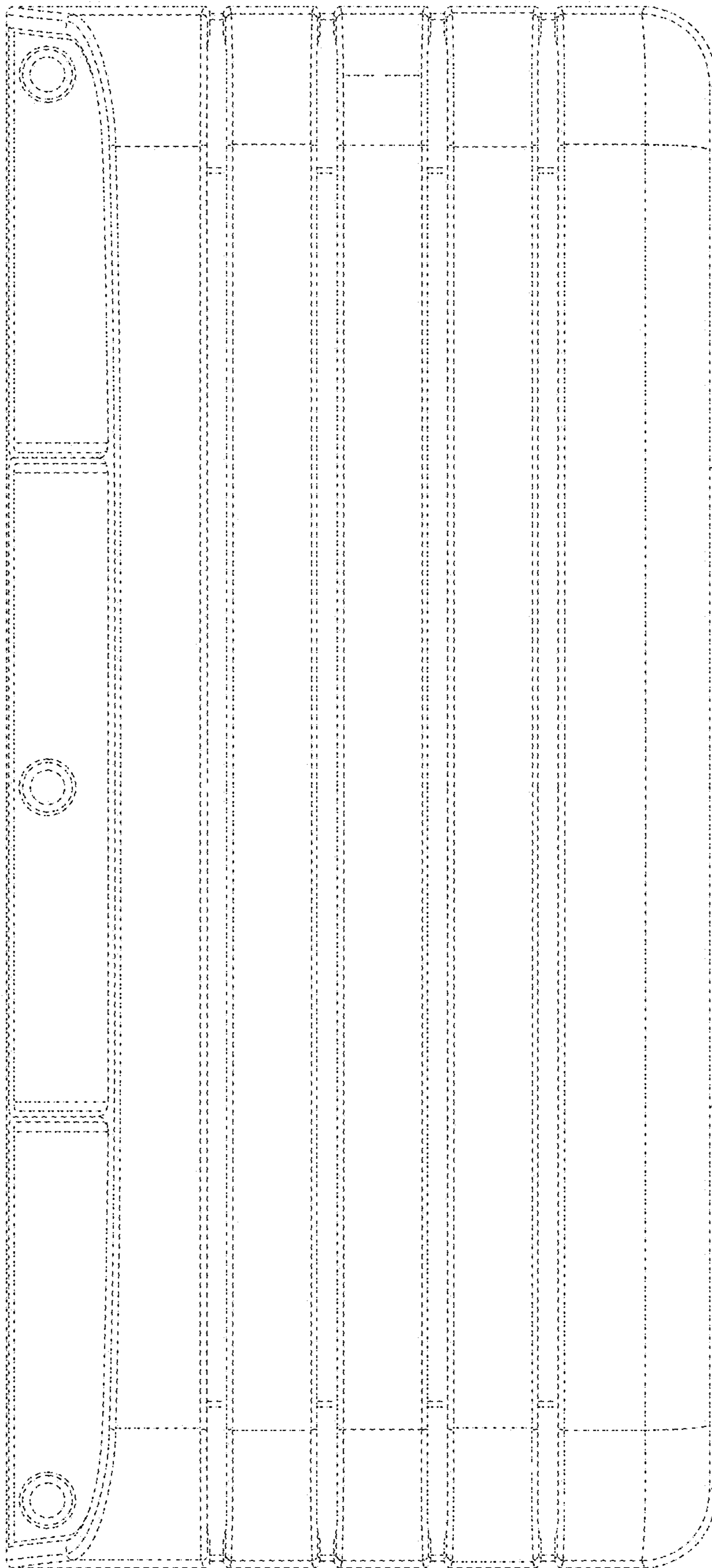

FIG. 4

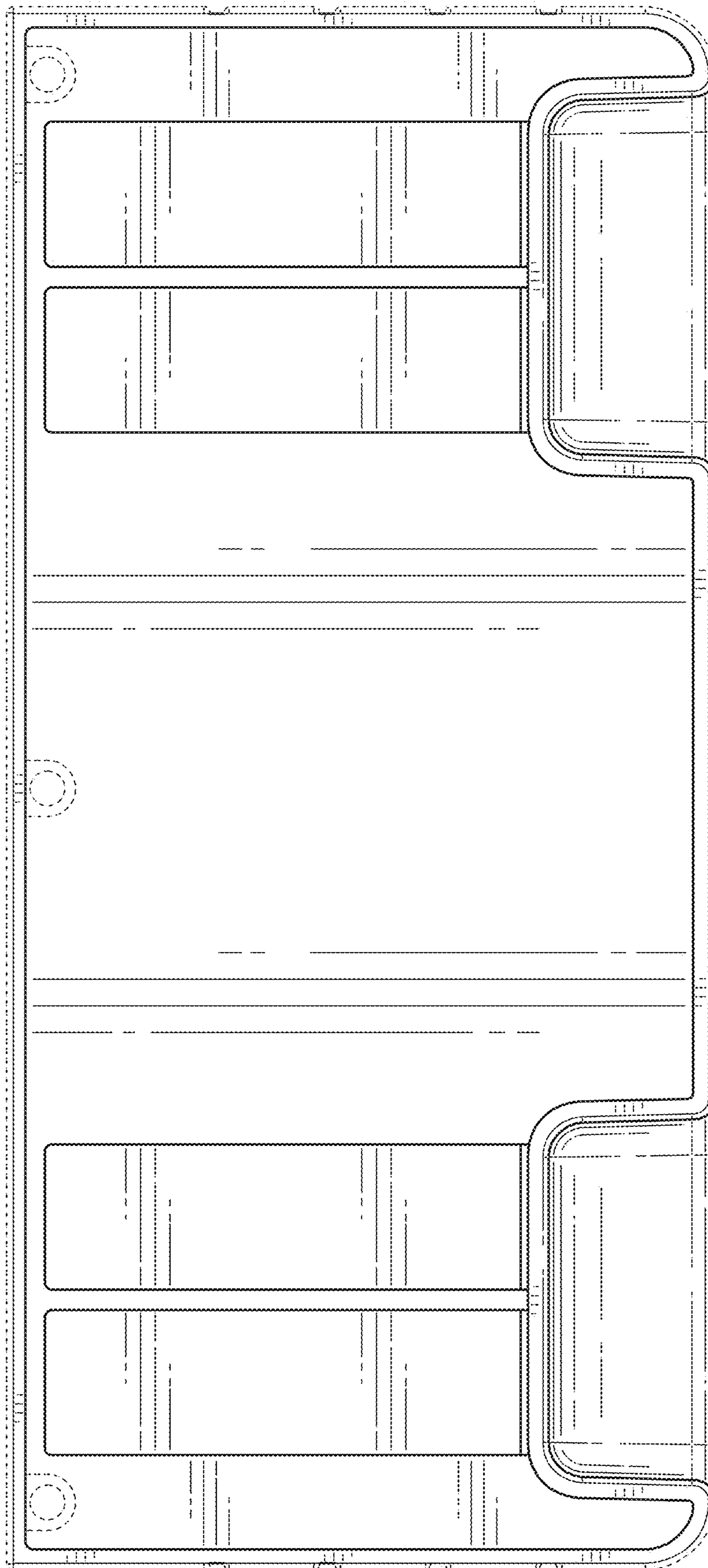

FIG. 5

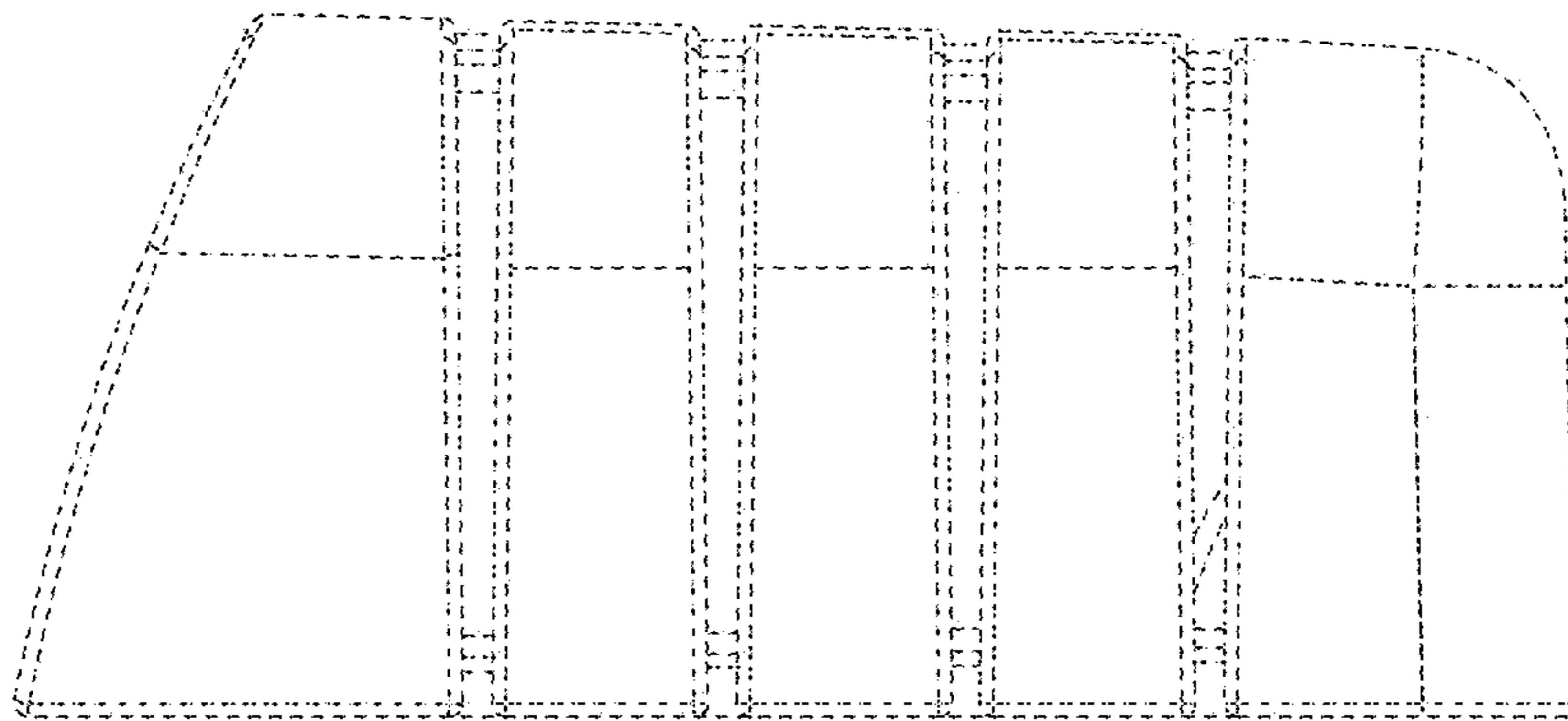

FIG. 6

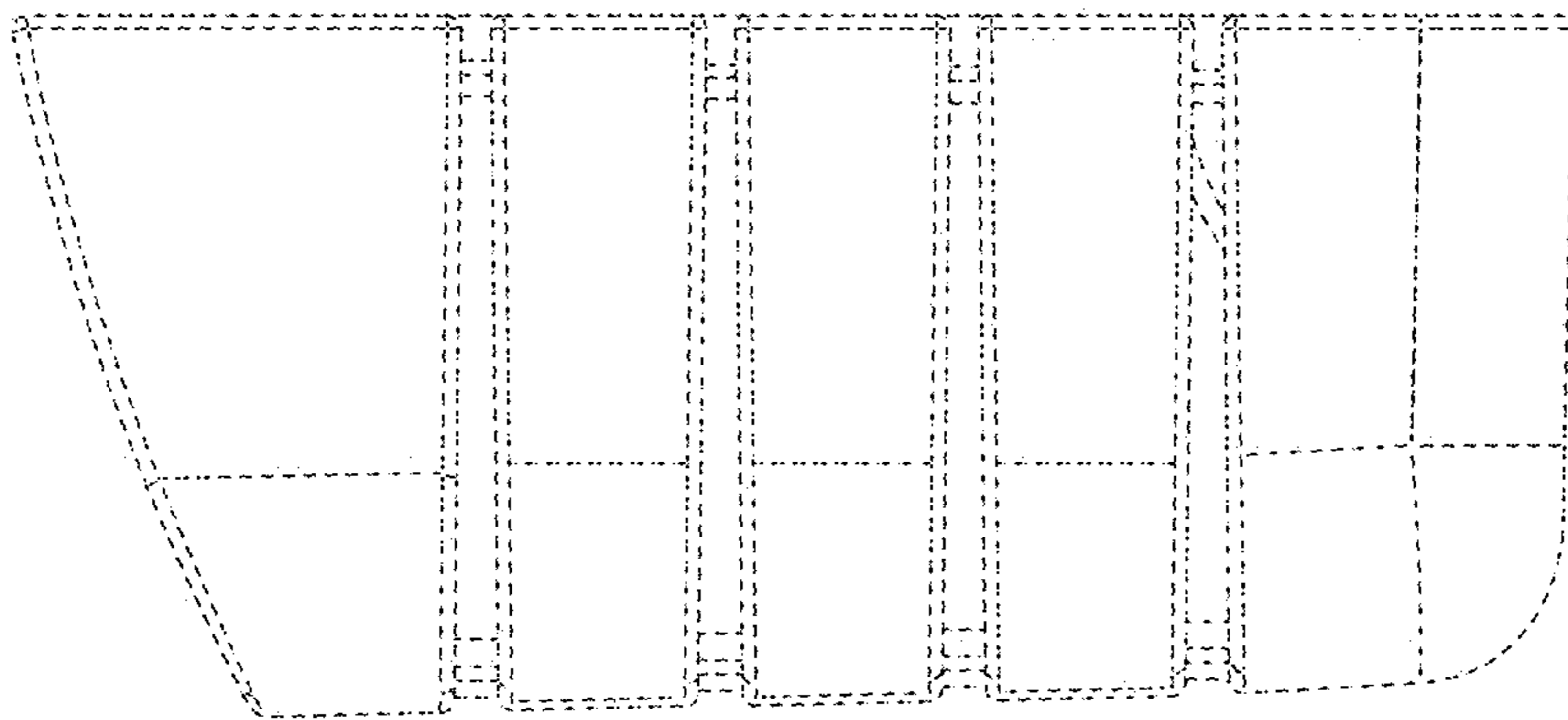

FIG. 7

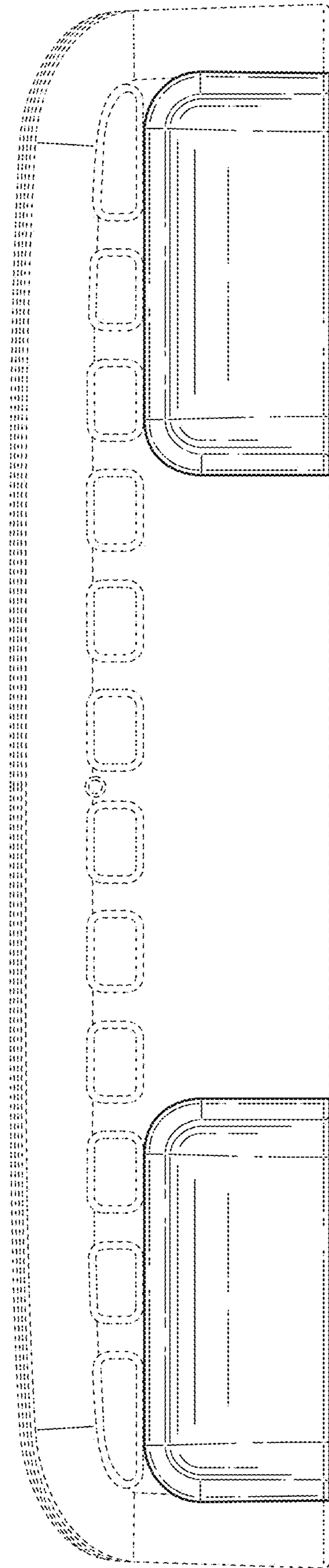

FIG. 8

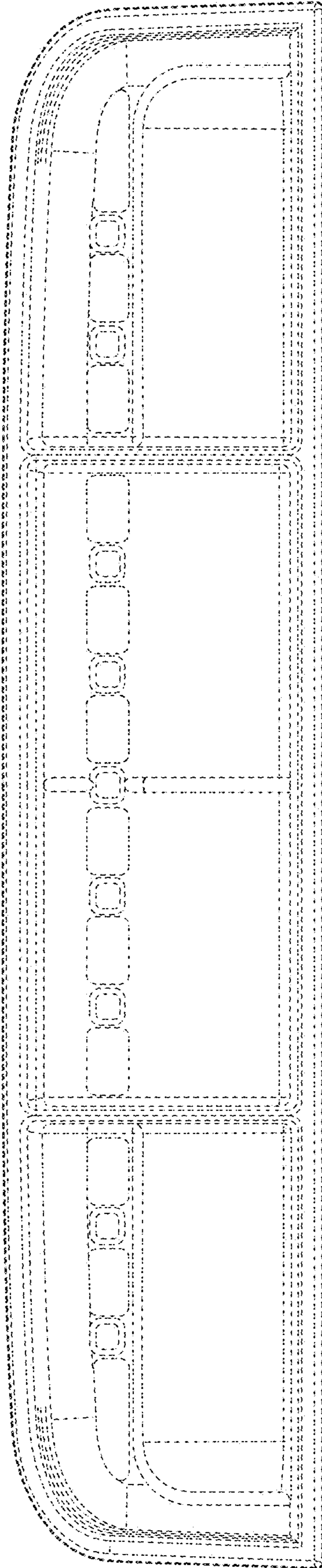

FIG. 9