



US00D927372S

(12) **United States Design Patent** (10) **Patent No.:** **US D927,372 S**
Phan et al. (45) **Date of Patent:** **** Aug. 10, 2021**

(54) **VEHICLE BUMPER**

(71) Applicant: **PACCAR Inc**, Bellevue, WA (US)
(72) Inventors: **Austin Hiep Phan**, Denton, TX (US);
Amanda Allison Koh, Seattle, WA (US)
(73) Assignee: **PACCAR Inc**, Bellevue, WA (US)
(**) Term: **15 Years**

(21) Appl. No.: **29/722,029**

(22) Filed: **Jan. 24, 2020**

(51) **LOC (13) Cl.** **12-16**

(52) **U.S. Cl.**
USPC **D12/169**

(58) **Field of Classification Search**
USPC D12/86, 90, 91, 92, 163, 169, 171, 196,
D12/216; D3/318
CPC B60R 19/02; B60R 19/04; B62D 25/00;
B62D 25/06; B62D 25/08; B62D 35/00
See application file for complete search history.

(56) **References Cited**

U.S. PATENT DOCUMENTS

364,072 A	5/1887	Wightman
D307,254 S	4/1990	Koske et al.
D316,241 S	4/1991	Ray
D343,605 S	1/1994	Meryman
D364,371 S	11/1995	Ray et al.
D381,946 S	8/1997	Delashaw et al.
D391,212 S	2/1998	Meryman et al.
D403,636 S	1/1999	Meryman et al.
D411,494 S	6/1999	Meryman et al.
D423,429 S	4/2000	Hickman et al.
D429,669 S	8/2000	Cook et al.
D476,929 S	7/2003	Dozier et al.
D482,302 S	11/2003	Dozier et al.
D504,850 S	5/2005	Gunter et al.
D518,424 S	4/2006	Clark et al.
D519,067 S	4/2006	Steere et al.

(Continued)

OTHER PUBLICATIONS

Lyon, Peter. "The Indestructible Toyota Land Cruiser to Get Turbo Hybrid for First Time." Aug. 31, 2019. Forbes, <https://www.forbes.com/sites/peterlyon/2019/08/31/the-indestructible-toyota-land-cruiser-to-get-turbo-hybrid-for-first-time/?sh=6c7847333795>.*

(Continued)

Primary Examiner — Brett Miller

Assistant Examiner — Suzanne E Tisdell

(74) *Attorney, Agent, or Firm* — Seed IP Law Group LLP

(57) **CLAIM**

The ornamental design for a vehicle bumper, as shown and described.

DESCRIPTION

FIG. 1 is a top isometric view of a vehicle bumper, showing our new design.

FIG. 2 is a front elevational view thereof.

FIG. 3 is a rear elevational view thereof.

FIG. 4 is a right side elevational view thereof.

FIG. 5 is a top plan view thereof.

FIG. 6 is a bottom plan view thereof.

FIG. 7 is a top isometric view of a vehicle bumper, showing another embodiment of our new design, which is a mirror image of the vehicle bumper shown in FIGS. 1-6.

FIG. 8 is a front elevational view thereof.

FIG. 9 is a rear elevational view thereof.

FIG. 10 is a left side elevational view thereof.

FIG. 11 is a top plan view thereof; and,

FIG. 12 is a bottom plan view thereof.

Stippling and tangency lines in the drawings represent the three-dimensional contours of the design, and are not intended to indicate surface decoration. The broken lines shown in the drawings depict portions of the vehicle bumper that form no part of the claimed design.

1 Claim, 8 Drawing Sheets

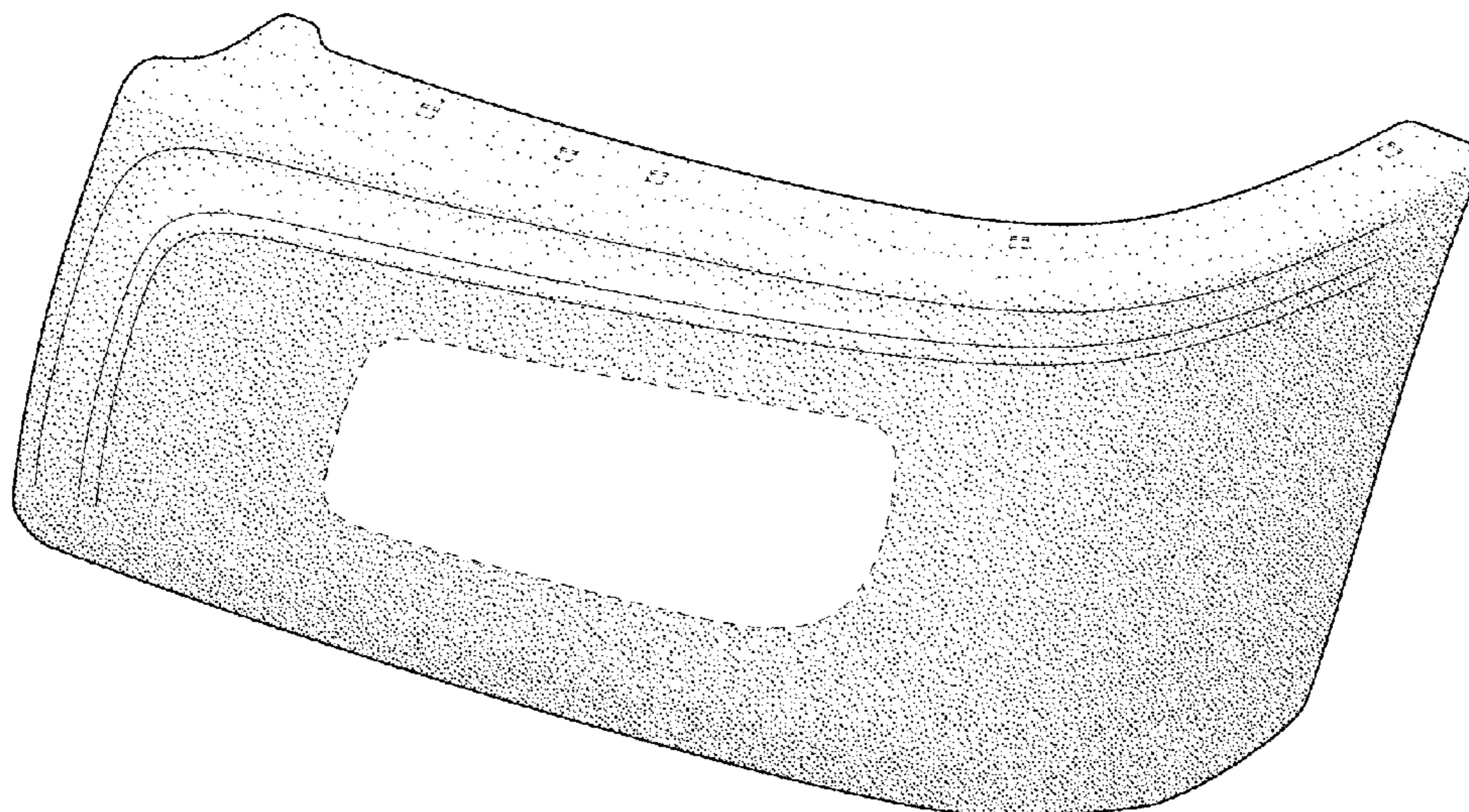

(56)

References Cited

U.S. PATENT DOCUMENTS

D519,068 S	4/2006	Clark et al.	
D519,069 S	4/2006	Clark et al.	
D530,653 S	10/2006	Angelo et al.	
D531,940 S	11/2006	McCuller et al.	
D540,722 S	4/2007	Angelo et al.	
D545,248 S	6/2007	Angelo et al.	
D563,840 S	3/2008	Simons et al.	
D565,484 S	4/2008	Johnson et al.	
D584,664 S	1/2009	Johnson et al.	
D584,665 S	1/2009	Johnson et al.	
D621,752 S	8/2010	Angelo et al.	
D633,419 S	3/2011	Peltola et al.	
D647,013 S	10/2011	Ito et al.	
D653,999 S	2/2012	Peltola et al.	
D684,508 S	6/2013	Peltola et al.	
D686,545 S	7/2013	Peltola et al.	
D702,162 S	4/2014	Heilaneh et al.	
D704,107 S	5/2014	Peltola et al.	
D709,807 S	7/2014	Heilaneh et al.	
D710,767 S	8/2014	Heilaneh et al.	
D725,008 S	3/2015	Peltola et al.	
D728,239 S *	5/2015	Sanz	D3/318
D740,730 S	10/2015	Peltola et al.	
D763,745 S	8/2016	Lee, IV et al.	
9,637,185 B2 *	5/2017	Kishima	B62D 37/02
10,118,648 B2 *	11/2018	Hallik	B62D 25/087
10,245,932 B1 *	4/2019	Suzuki	B62D 21/152
10,252,753 B2 *	4/2019	Johnson	B62D 25/18
D848,911 S *	5/2019	De Leon	D12/169
10,300,958 B2 *	5/2019	Kato	B62D 25/08
D853,905 S *	7/2019	Betancourt	D12/169
D855,528 S *	8/2019	Re	D12/196
D865,588 S *	11/2019	Hong	D12/169
D867,234 S *	11/2019	Peplowski	D12/169
D871,259 S *	12/2019	Yamashita	D12/91
D871,279 S *	12/2019	Tonello	D12/169
D875,607 S *	2/2020	Lida	D12/92
D877,658 S *	3/2020	Burki	D12/91
D882,468 S *	4/2020	Sperling	D12/169
D885,266 S *	5/2020	Kezha	D12/169
D887,327 S *	6/2020	Zurian	D12/169
D887,915 S *	6/2020	Davidson	D12/169
D890,043 S *	7/2020	Choi	D12/169
D891,107 S *	7/2020	Paik	D3/318
D891,320 S *	7/2020	Metros	D12/169
D896,712 S *	9/2020	Lu	D12/169
D897,199 S *	9/2020	Armistead	D9/434

OTHER PUBLICATIONS

Huetter, John. "Honda Releases Repair Overview for 2016 Civic: An 'F-150 Moment' for Steel Cars." Nov. 10, 2015. Repairer Driven News. <https://www.repairerdrivennews.com/2015/11/10/honda-releases-repair-overview-for-2016-civic-an-f-150-moment-for-steel-cars/>.*

Beintema, Rob. "First Drive: 2018 Ford EcoSport." May 22, 2018. Wheels. <https://www.wheels.ca/car-reviews/first-drive-2018-ford-ecosport/>.*

"T800," Kenworth Truck Company, 2002, 32-page brochure.

"T800," Kenworth Truck Company, 2003, 32-page brochure.

"T800," Kenworth Truck Company, 2005, 28-page brochure.

"T800," Kenworth Truck Company, 2009, 28-page brochure.

"T800B," Kenworth Truck Company, 1993, 8-page brochure.

Peterbilt Motors Company, "The Working Class," Sep. 1976, 6-page brochure.

"The World's Best," Kenworth Truck Company, 1992, 12-page brochure.

"W900," Kenworth Truck Company, 1996, 7-page brochure.

"W900," Kenworth Truck Company, 2002, 32-page brochure.

"W900," Kenworth Truck Company, 2005, 32-page brochure.

"W900," Kenworth Truck Company, 2009, 28-page brochure.

Kenworth Truck Company, "W900L AeroCab," 1994, 2-page brochure.

Kenworth Truck Company, "AeroCab," 1993, 6-page brochure.

"AeroCab," Kenworth Truck Company, as early as 1995, 3-page brochure.

"C500B," Kenworth Truck Company, as early as 1990, 4-page brochure.

Peterbilt Motors Company, "Class Pays, Medium Duty," Sep. 2000, 12-page brochure.

"Class Pays, Truck Models," Peterbilt Motors Company, Mar. 2005, 24-page brochure.

"Class Pays," Peterbilt Motors Company, Nov. 1998, 10-page brochure.

Peterbilt Motors Coinpany, "Class Pays," Sep. 1997, 10-page brochure.

"Class Pays, Construction Trucks," Peterbilt Motors Company, Nov. 2003, 16-page brochure.

"Kenworth Truck Models," Kenworth Truck Company, 2010, 16-page brochure.

Peterbilt Motors Company, "Model 330," Oct. 1997, 3-page brochure.

Peterbilt Motors Company, "Model 379," Apr. 2005, 2-page brochure.

Peterbilt Motors Company, "Model 379," Mar. 1996, 5-page brochure.

Peterbilt Motors Company, "Rest with Class," Apr. 1978, 4-page brochure.

"T170 Class 5," Kenworth Truck Company, 2008, 4-page brochure.

"T270 Class 6 and T370 Class 7," Kenworth Truck Company, 2008, 6-page brochure.

"T270 Class 6 and T370 Class 7," Kenworth Truck Company, 2009, 6-page brochure.

"T270 Class 6 and T370 Class 7 Hybrid," Kenworth Truck Company, 2009, 6-page brochure.

"T680," Kenworth Truck Company, 2013, 34-page brochure.

"T680," Kenworth Truck Company, 2016, 34-page brochure.

"T880," Kenworth Truck Company, 2017, 32-page brochure.

"Model 579," Peterbilt Motors Company, Oct. 2013, 13-page brochure.

"Medium Duty," Peterbilt Motors Company, 2013, 9-page brochure.

"On-Highway," Peterbilt Motors Company, 2013, 13-page brochure.

"Vocational," Peterbilt Motors Company, 2013, 11-page brochure.

"T440," Kenworth Truck Company, 2010, 6-page brochure.

"T470," Kenworth Truck Company, 2010, 6-page brochure.

"T470H," Kenworth Truck Company, 2009, 2-page brochure.

"Model 220," Peterbilt Motors Company, 2019, 2-page brochure.

"220EV," Peterbilt Motors Company, 2020, 5-page brochure.

"Model 337," Peterbilt Motors Company, 2020, 2-page brochure.

"Model 389," Peterbilt Motors Company, 2019, 2-page brochure.

"Model 348," Peterbilt Motors Company, 2019, 2-page brochure.

"Model 520," Peterbilt Motors Company, 2019, 2-page brochure.

"Model 567," Peterbilt Motors Company, 2020, 16-page brochure.

"567 Heritage," Peterbilt Motors Company, 2017, 2-page brochure.

"Model 579," Peterbilt Motors Company, 2019, 28-page brochure.

"C500," Kenworth Truck Company, 2012, 2-page brochure.

"T680," Kenworth Truck Company, 2019, 40-page brochure.

"T800," Kenworth Truck Company, 2012, 28-page brochure.

"T440/T470," Kenworth Truck Company, 2015, 8-page brochure.

"K270E/K370E," Kenworth Truck Company, 2020, 4-page brochure.

"T270/T370," Kenworth Truck Company, 2019, 16-page brochure.

"K270/K370," Kenworth Truck Company, 2014, 12-page brochure.

"W990," Kenworth Truck Company, 2018, 32-page brochure.

"T880," Kenworth Truck Company, 2019, 36-page brochure.

"Model 367," Peterbilt Motors Company, <https://www.peterbilt.com/trucks/vocational/model-367>, retrieved Nov. 20, 2020, 12 pages.

"Model 365," Peterbilt Motors Company, <https://www.peterbilt.com/trucks/vocational/model-365>, retrieved Nov. 20, 2020, 11 pages.

"Model 325," Peterbilt Motors Company, <https://www.peterbilt.com/trucks/medium-duty/model-325>, retrieved Nov. 20, 2020, 12 pages.

* cited by examiner

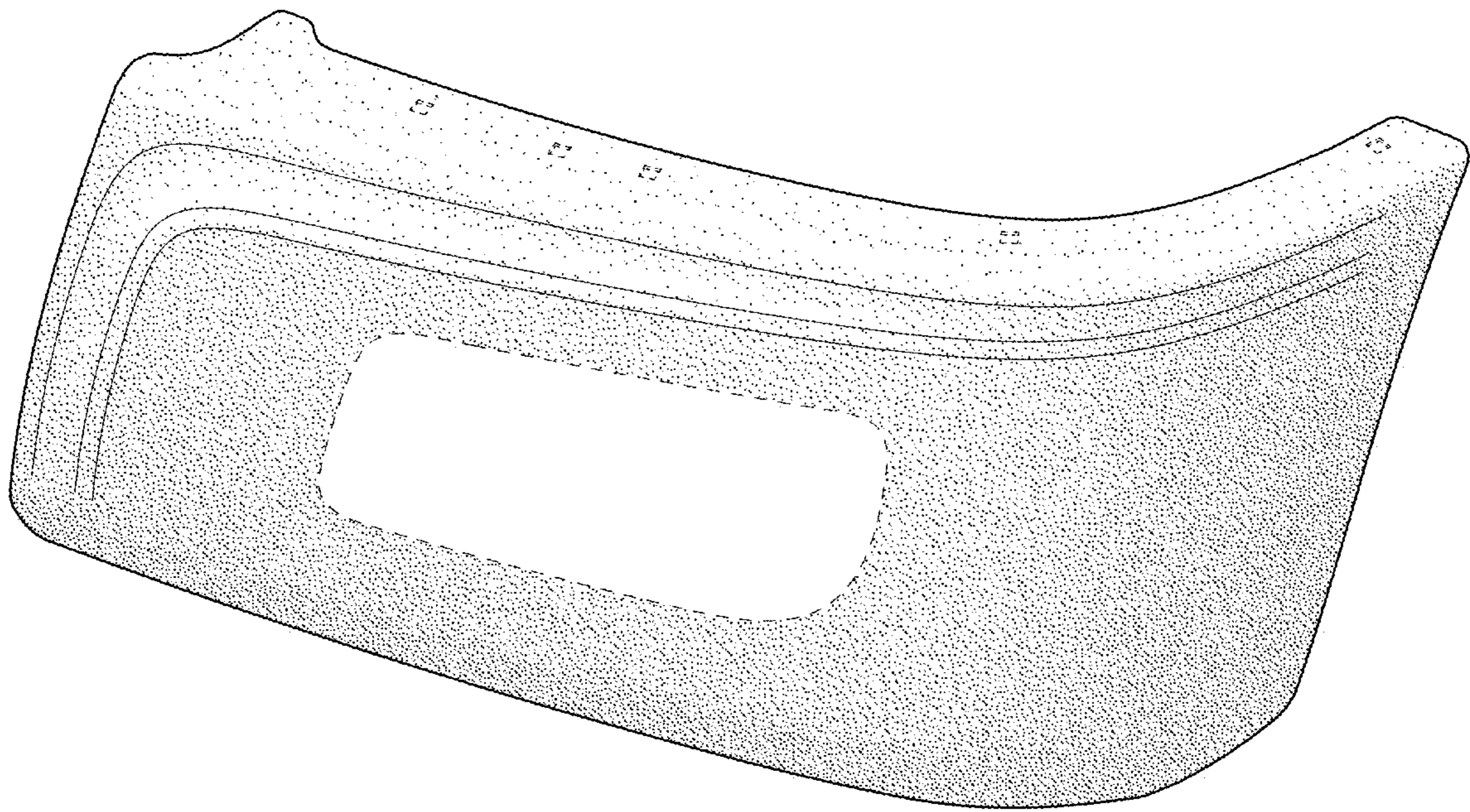

FIG. 1

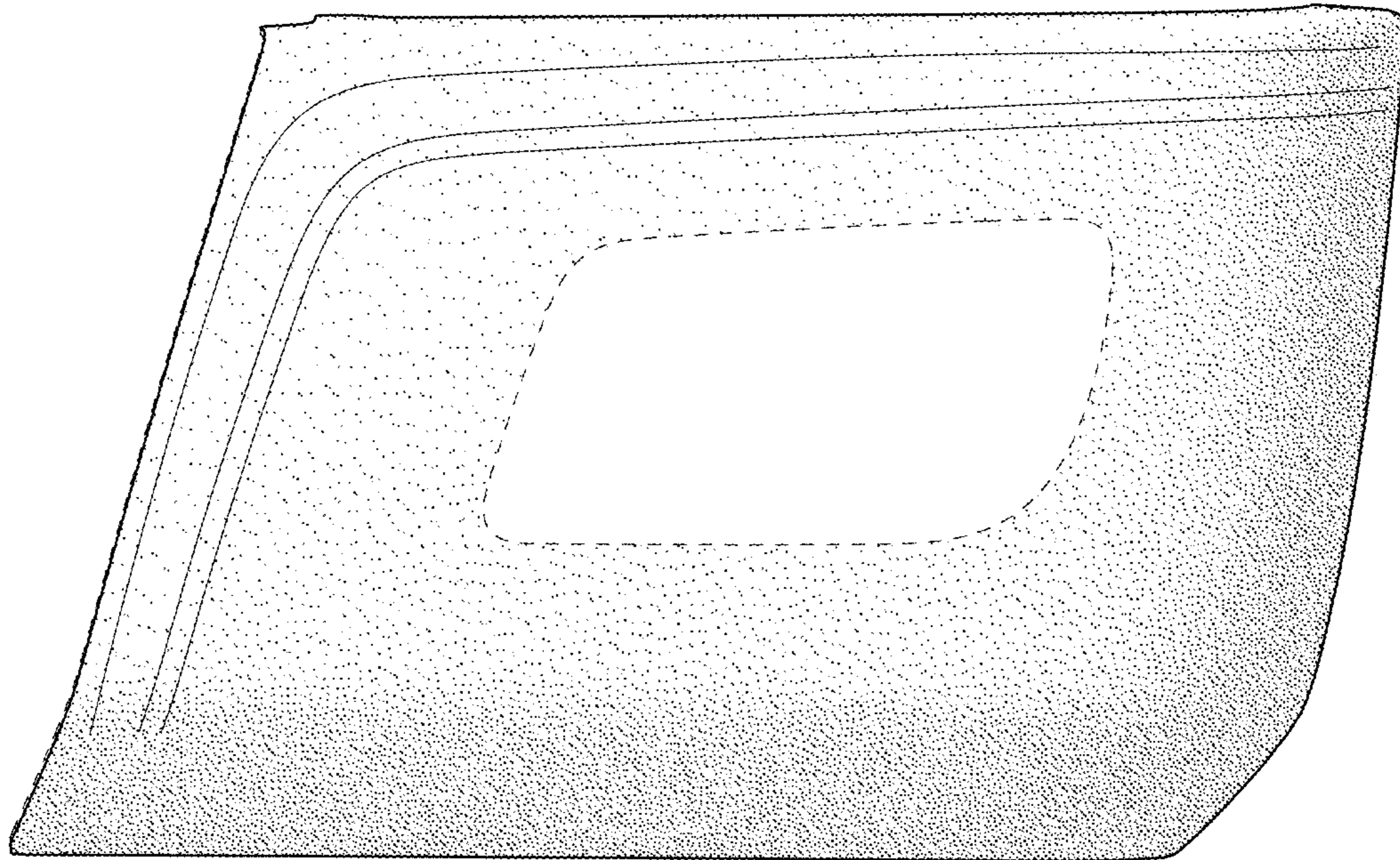

FIG. 2

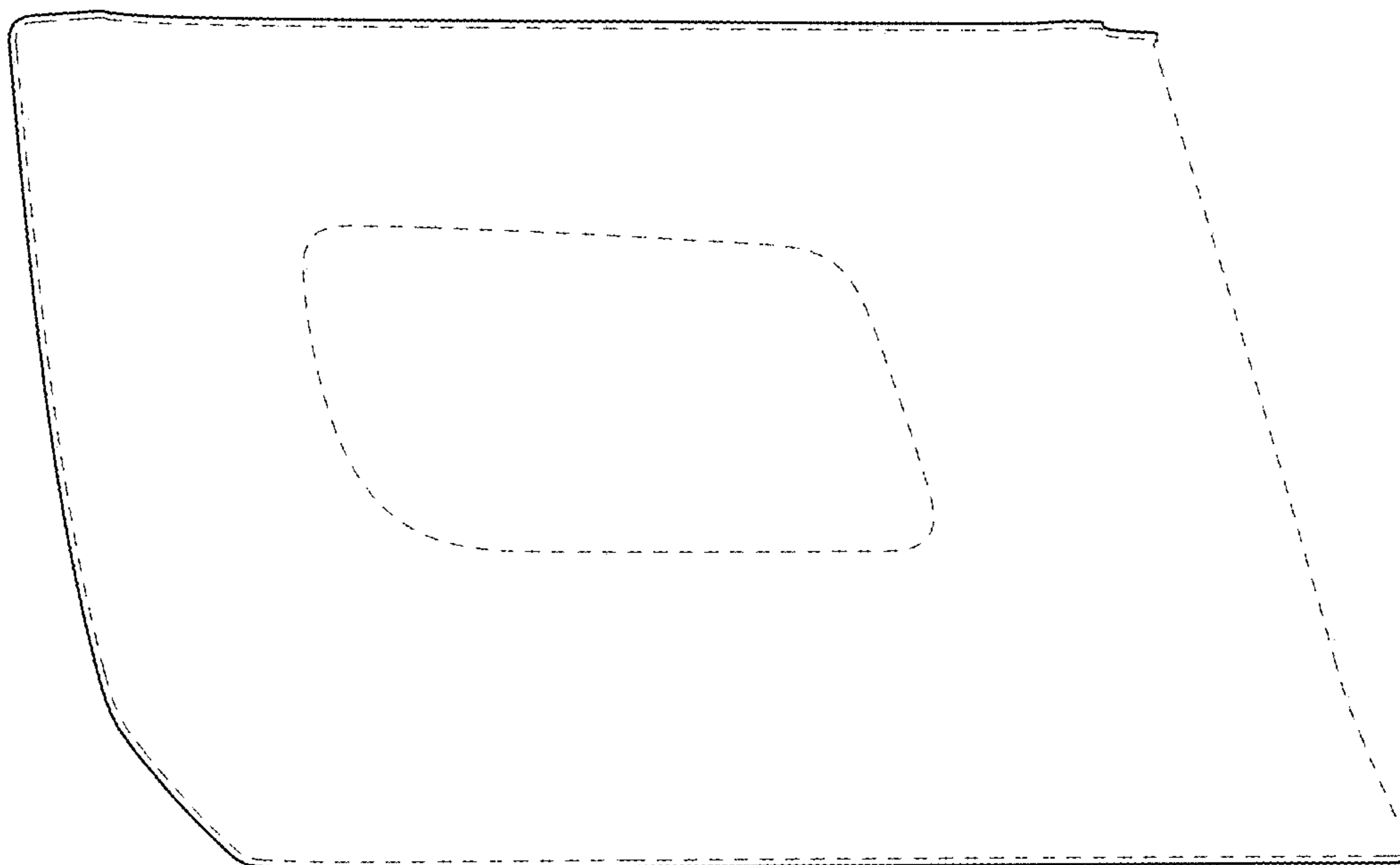

FIG. 3

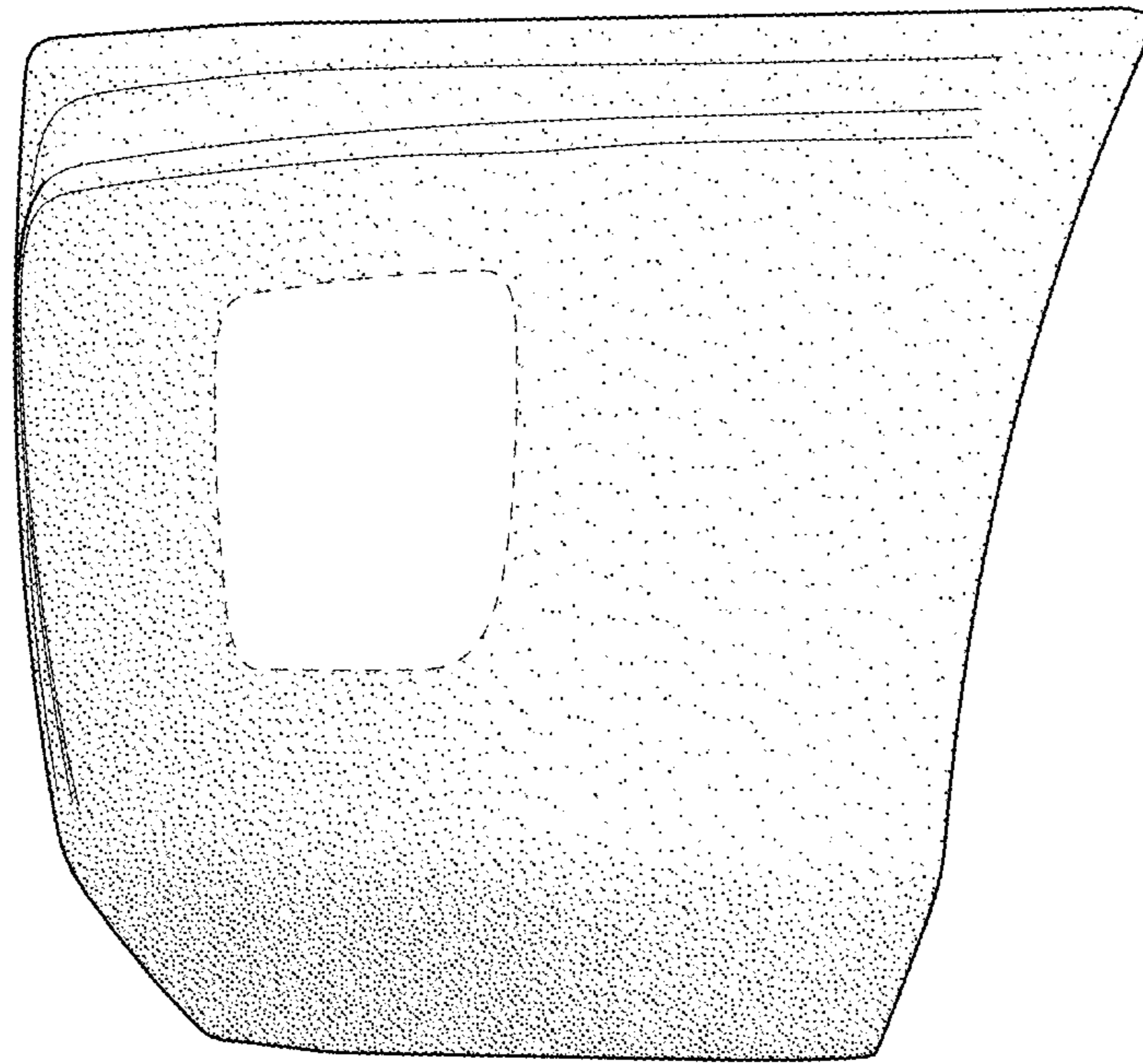

FIG. 4

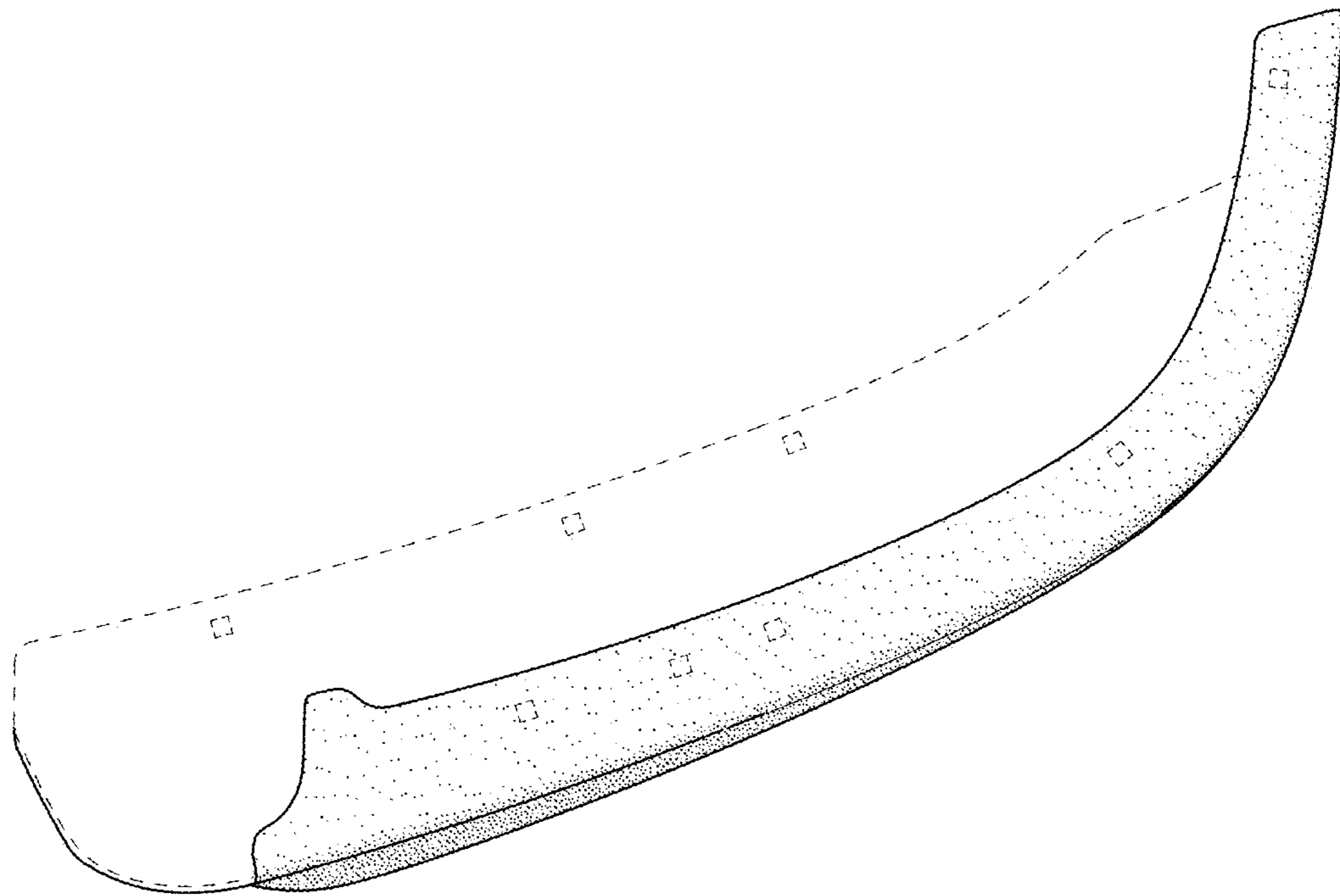

FIG. 5

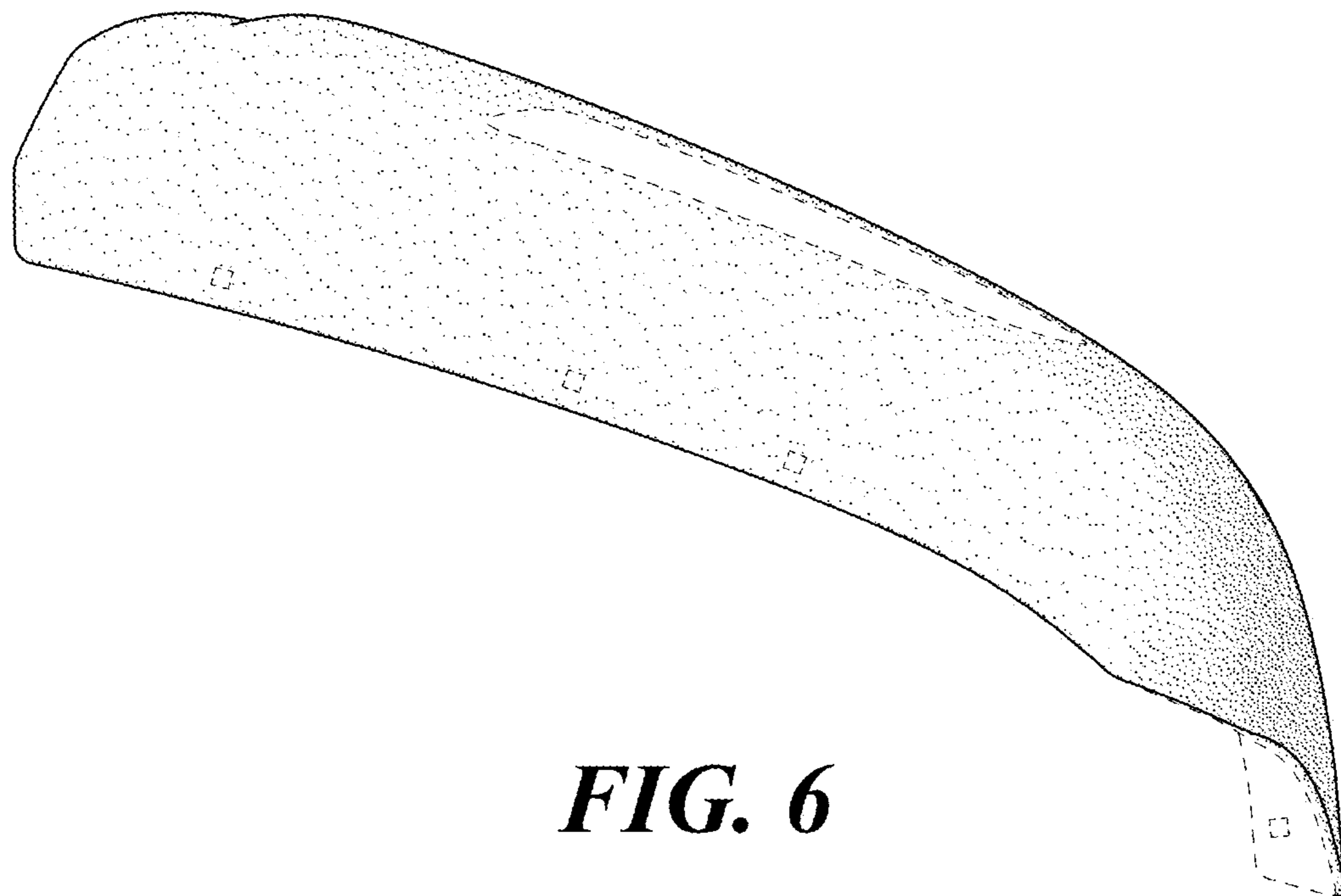

FIG. 6

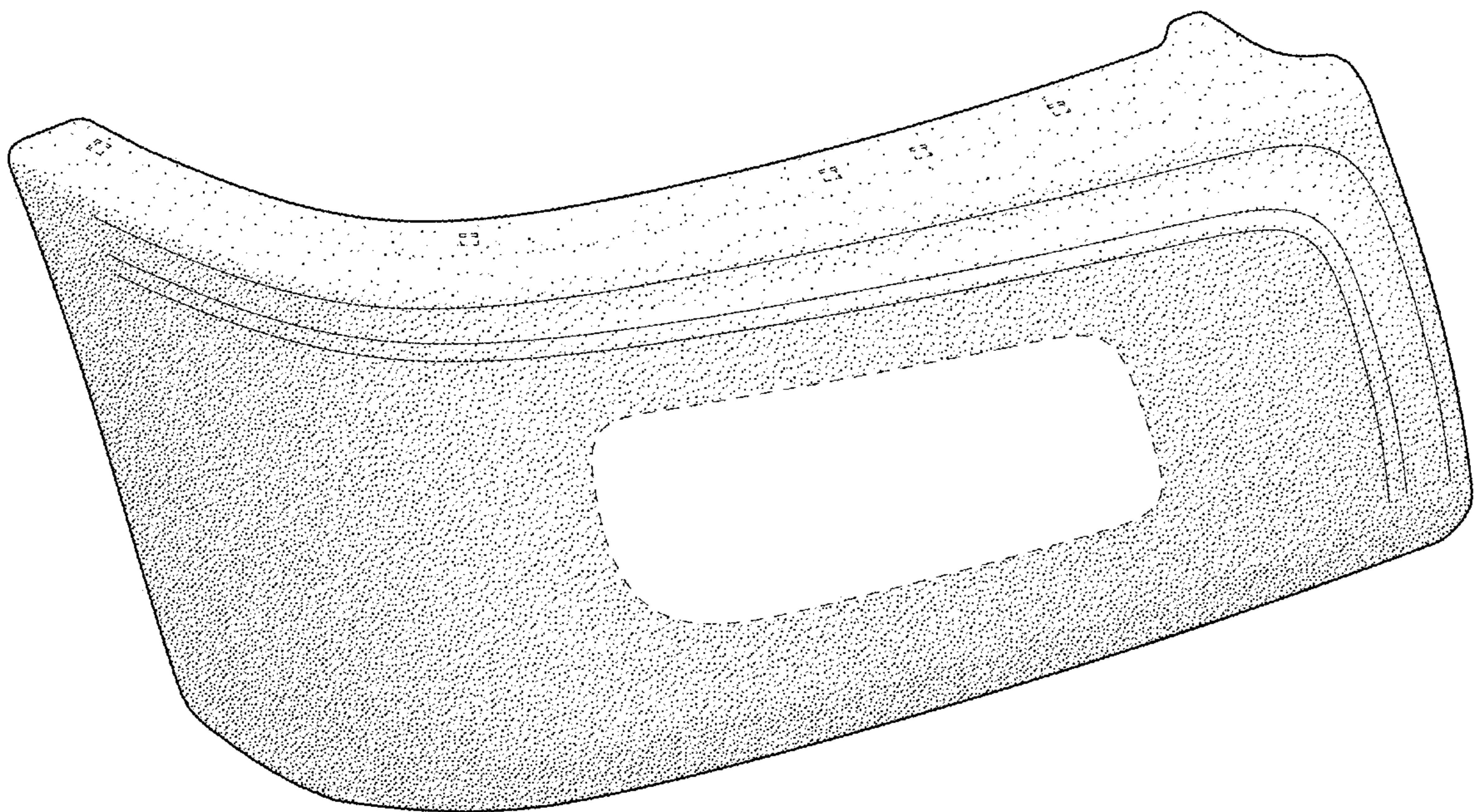

FIG. 7

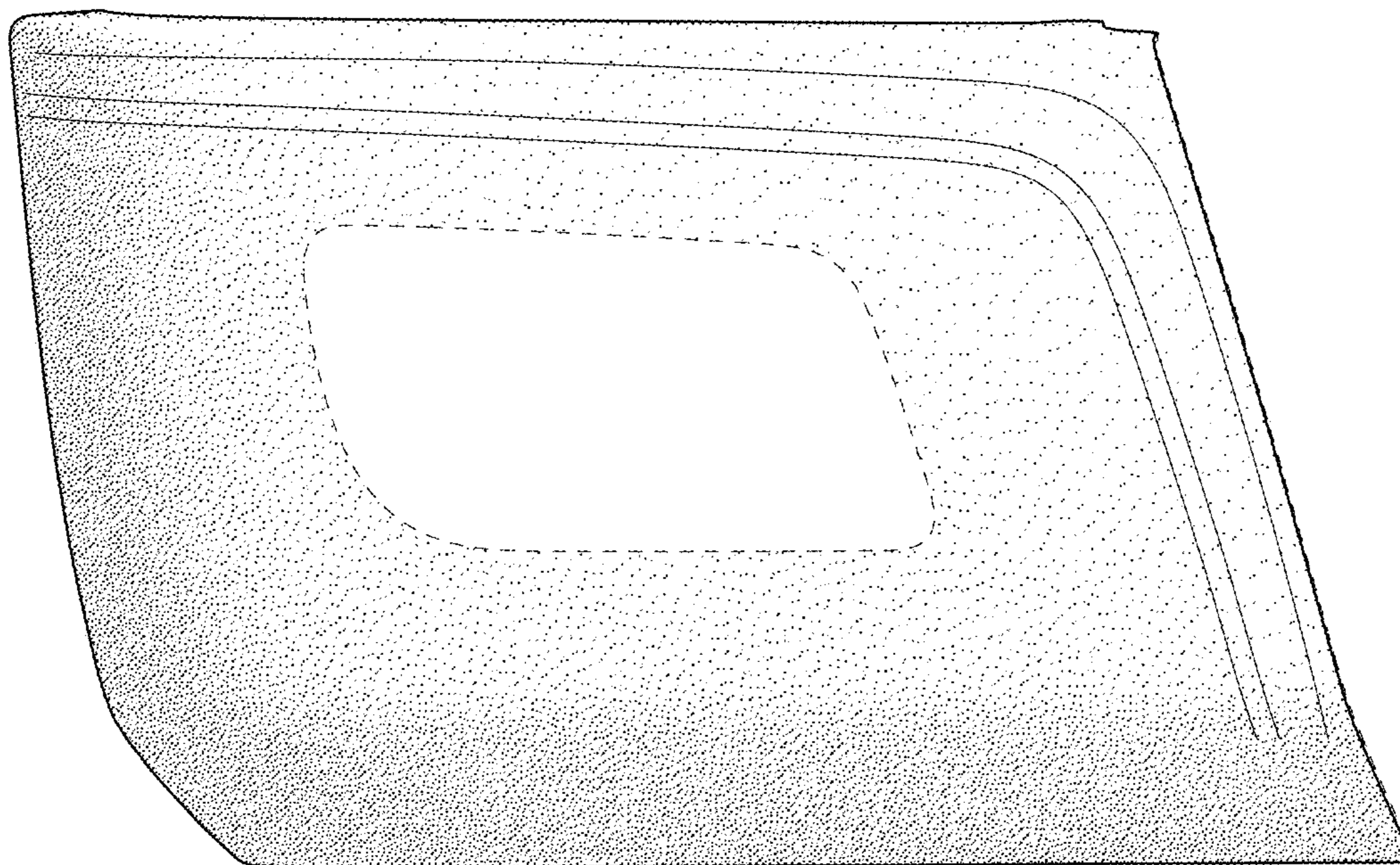

FIG. 8

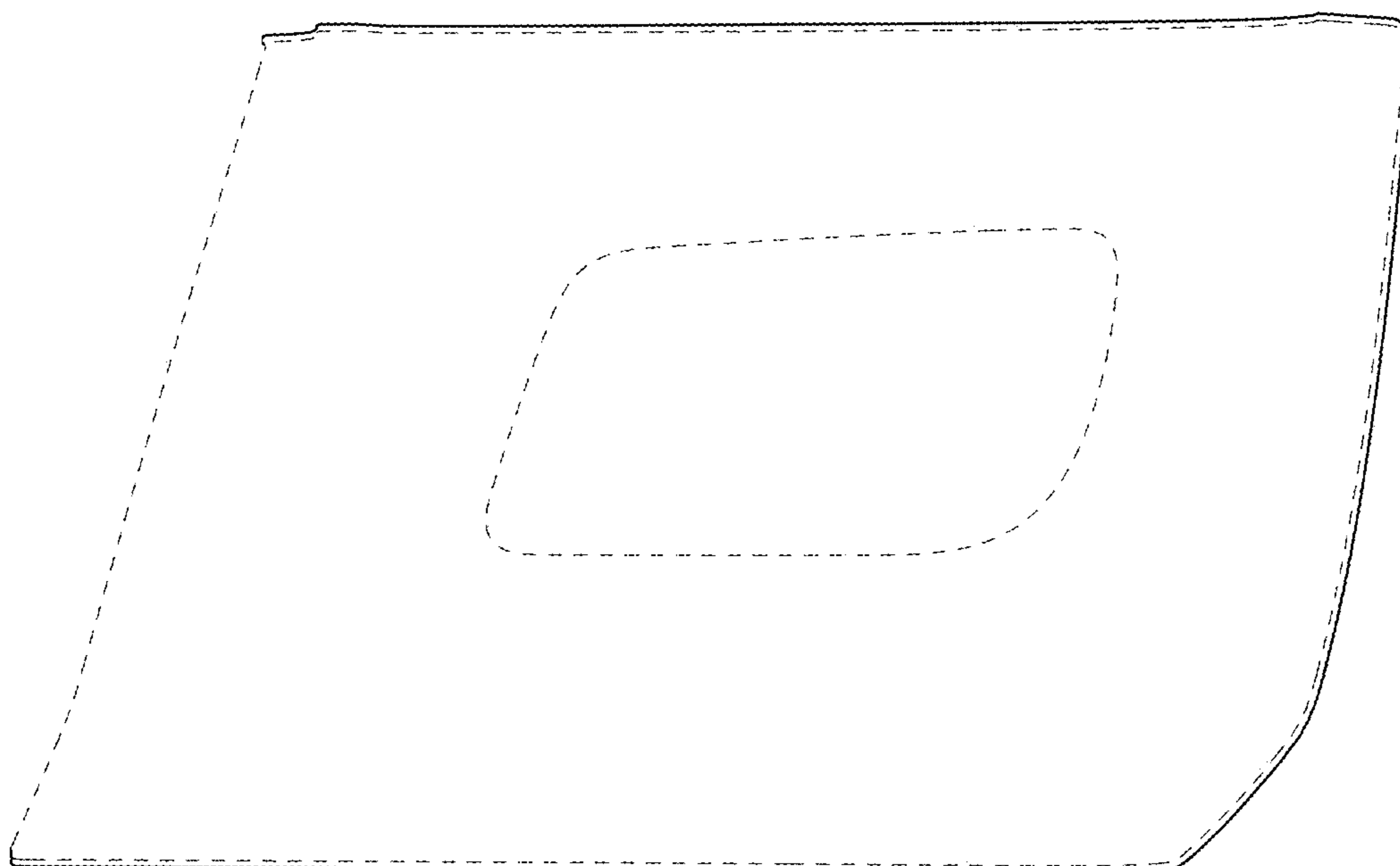

FIG. 9

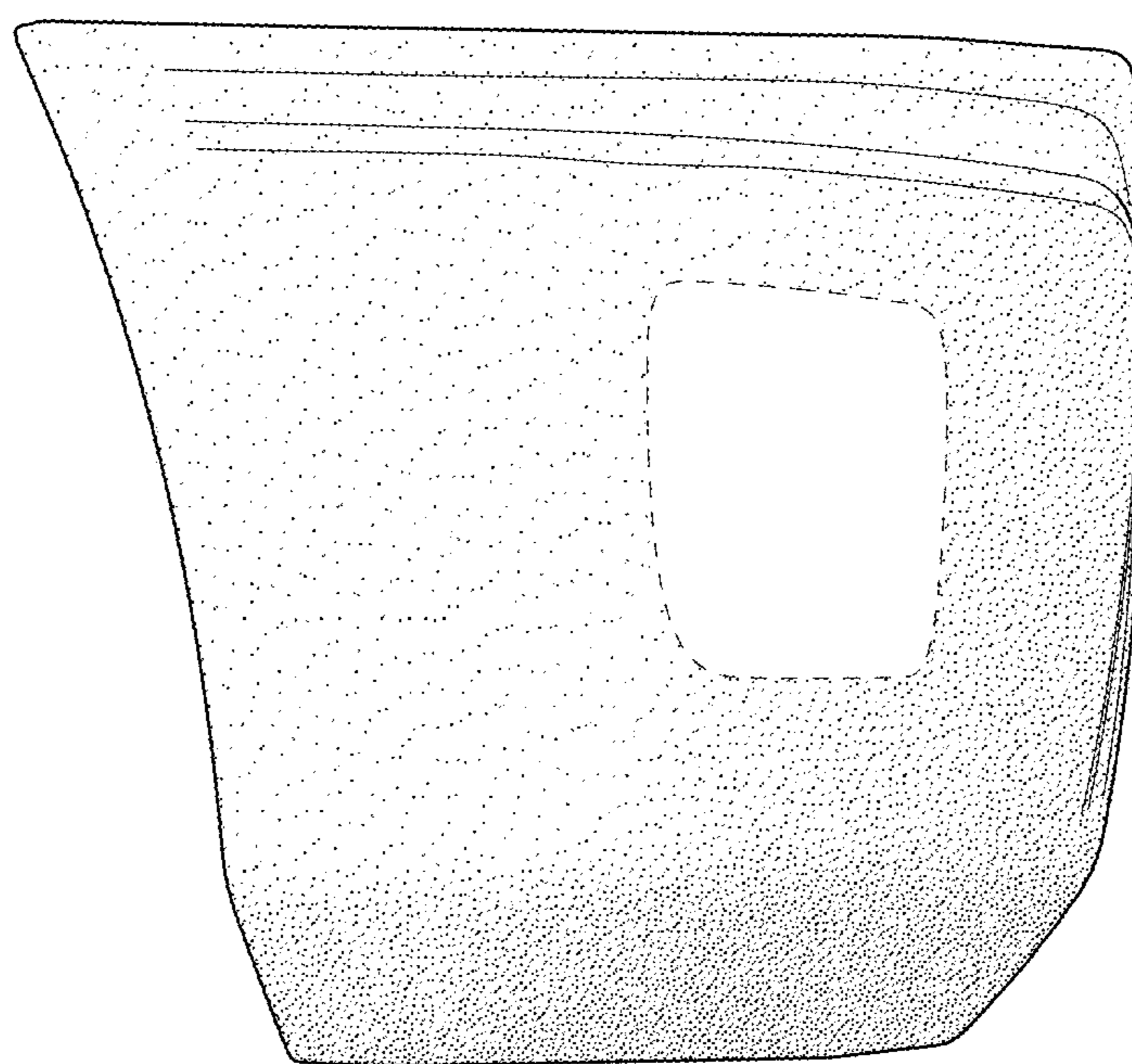

FIG. 10

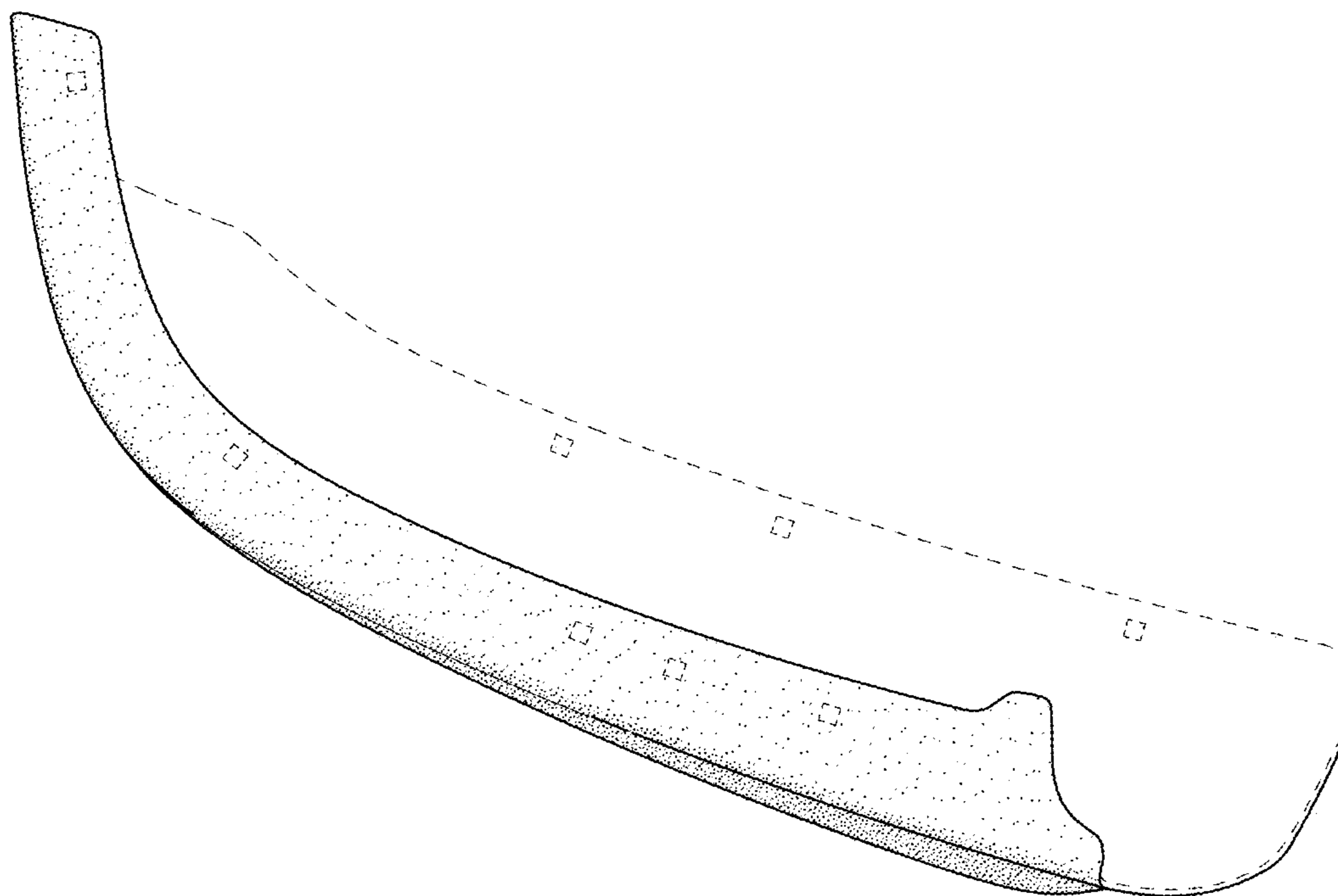

FIG. 11

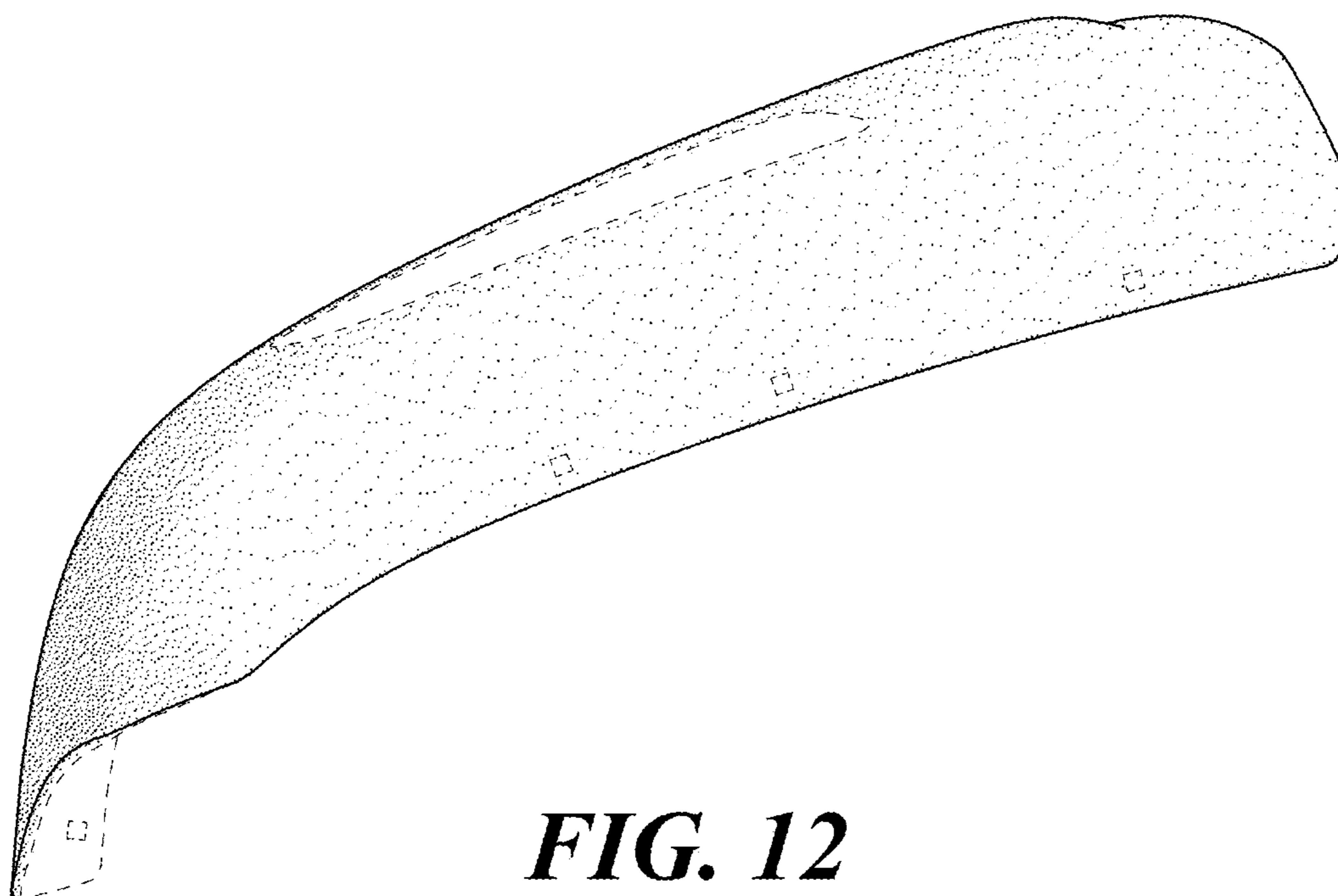

FIG. 12