



US00D927255S

(12) **United States Design Patent** (10) **Patent No.:** **US D927,255 S**
McConnell et al. (45) **Date of Patent:** **** Aug. 10, 2021**

(54) **GRINDER PLATE AND CLEANER ACCESSORY ASSEMBLY**

18/302; B02C 18/304; B02C 18/305; B02C 18/362; B02C 18/365; B02C 25/00; B02C

(71) Applicant: **WHIRLPOOL CORPORATION**,
Benton Harbor, MI (US)

(Continued)

(72) Inventors: **John W. McConnell**, St. Joseph, MI (US); **Nicholas Schutte**, St. Joseph, MI (US); **Anne Wessel**, St. Joseph, MI (US)

(56)

References Cited

U.S. PATENT DOCUMENTS

62,184 A 2/1867 Coe
100,280 A 3/1870 Gerhard

(Continued)

(73) Assignee: **Whirlpool Corporation**, Benton Harbor, MI (US)

FOREIGN PATENT DOCUMENTS

(**) Term: **15 Years**

CA 2131560 7/1994
DE 202010012730 U1 12/2010

(Continued)

(21) Appl. No.: **29/767,224**

(22) Filed: **Jan. 21, 2021**

OTHER PUBLICATIONS

“Fulfilling Finishing Needs in the Auto Industry”; Electro Polish; Black Oxide, Aluminum Anodizing, Passivation; Dayton, Ohio; pp. 1-3; 2013.

(Continued)

Related U.S. Application Data

(60) Continuation of application No. 29/756,103, filed on Oct. 26, 2020, now Pat. No. Des. 909,814, which is a
(Continued)

(51) **LOC (13) Cl.** **31-00**

(52) **U.S. Cl.**
USPC **D7/412; D7/372**

(58) **Field of Classification Search**
USPC D7/323, 352-362, 372, 376-386, 402, D7/409-411, 665-666, 669, 678-679, D7/693-694; D8/32, 70

CPC A01F 2015/07; A01F 2015/077; A01F 2015/0775; A23N 1/00; A23N 1/02; A47J 19/00; A47J 19/005; A47J 19/02; A47J 19/04; A47J 19/06; A47J 42/32; A47J 42/34; A47J 42/36; A47J 43/044; A47J 43/06; A47J 43/25; A47J 43/255; B01F 7/26; B01F 7/28; B01F 11/0082; B01F 13/04; B02C 13/00; B02C 13/02; B02C 13/10; B02C 18/06; B02C 18/26; B02C 18/30; B02C 18/34; B02C 18/36; B02C

Primary Examiner — Ricky Pham

(74) *Attorney, Agent, or Firm* — Price Heneveld LLP

(57)

CLAIM

The ornamental design for a grinder plate and cleaner accessory assembly, as shown.

DESCRIPTION

FIG. 1 is a perspective view of a grinder plate and cleaner accessory assembly according to the design; FIG. 2 is a front elevation view thereof; FIG. 3 is a back elevation view thereof; FIG. 4 is a right side elevation view thereof; FIG. 5 is a left side elevation view thereof; FIG. 6 is a top plan view thereof; and, FIG. 7 is a bottom plan view thereof.

1 Claim, 5 Drawing Sheets

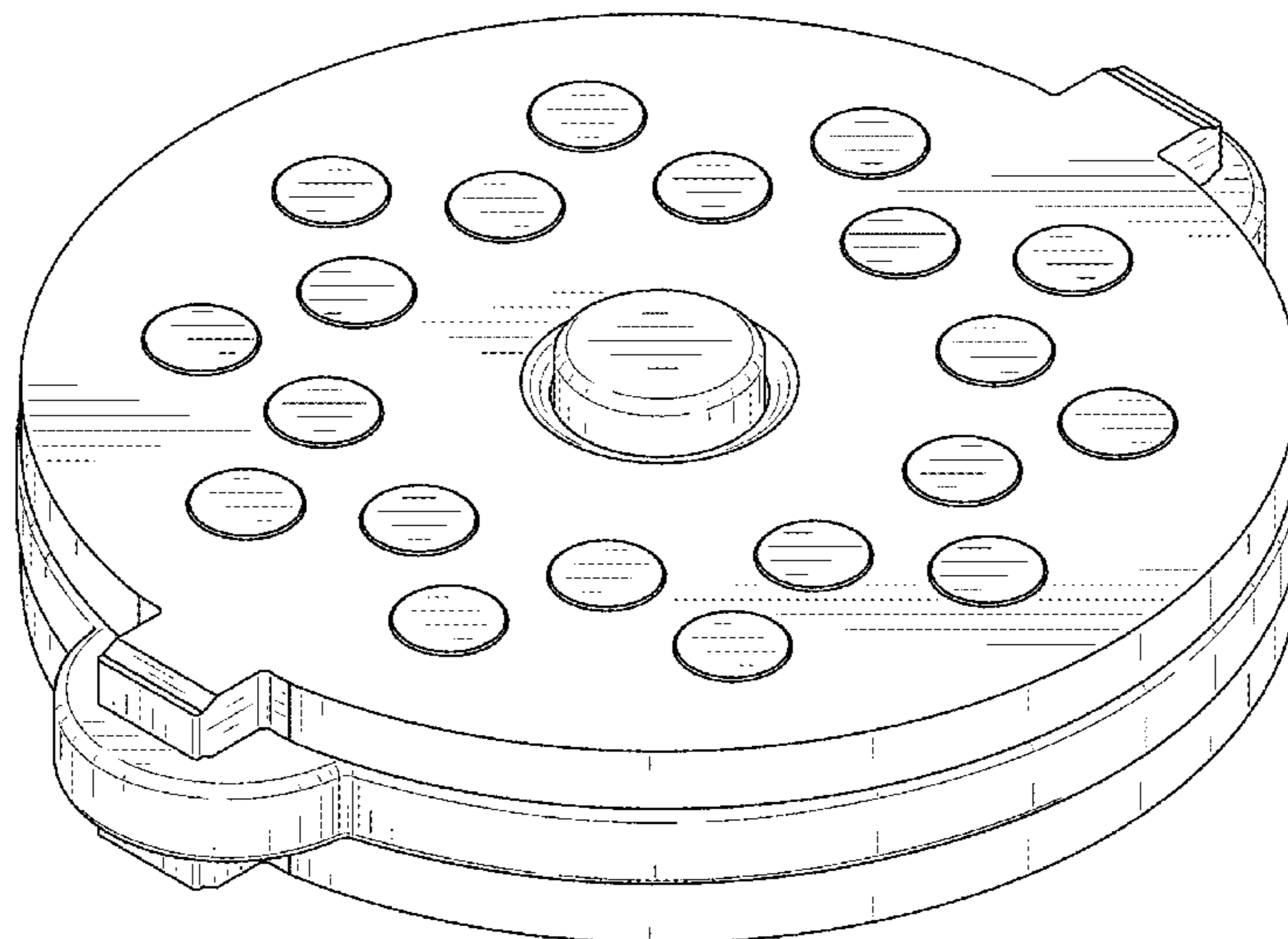

Related U.S. Application Data

continuation of application No. 29/738,407, filed on Jun. 17, 2020, now Pat. No. Des. 902,640, which is a continuation of application No. 29/723,667, filed on Feb. 10, 2020, now Pat. No. Des. 891,853, which is a continuation of application No. 29/705,144, filed on Sep. 10, 2019, now Pat. No. Des. 878,146, which is a division of application No. 29/621,122, filed on Oct. 4, 2017, now Pat. No. Des. 867,051.

- (58) **Field of Classification Search**
 CPC 2002/00; B02C 2013/00; B02C 2013/14; B02C 2013/145; B02C 2013/18; B02C 2013/1807; B02C 2013/1857; B02C 2013/1864; B24D 11/00; B30B 9/00; B30B 9/16; B30B 9/18; B30B 9/20; B30B 9/26; B30B 9/205; B30B 9/207
 See application file for complete search history.

(56) **References Cited**

U.S. PATENT DOCUMENTS

243,035 A 6/1881 Geer
 256,214 A 4/1882 Heizmann
 256,800 A 4/1882 Holton
 273,418 A 3/1883 Whittemore
 310,196 A 1/1885 Goodell
 319,905 A 6/1885 Hudson
 360,527 A 4/1887 Hudson
 959,137 A 5/1910 Hinchliffe
 1,006,621 A 10/1911 Arnold
 1,008,555 A 11/1911 Mower
 1,647,196 A * 11/1927 Rollman B02C 18/36
 241/82.2
 1,826,242 A 10/1931 Dehuff
 1,956,492 A 4/1934 China
 2,001,036 A 5/1935 Prince
 2,056,843 A 10/1936 Erro
 2,125,859 A 8/1938 Liebelt
 2,146,710 A 2/1939 Bloomfield
 2,156,645 A 5/1939 Waller
 D118,270 S 12/1939 Strauss
 2,226,317 A * 12/1940 Myers B02C 18/34
 241/166
 2,281,258 A * 4/1942 Benton B02C 18/365
 241/89.1
 2,284,155 A 5/1942 Landgraf
 2,305,288 A 12/1942 Cavalleri
 2,409,067 A 10/1946 Reed
 2,410,683 A 11/1946 Rios Y Marquez
 2,464,993 A 3/1949 Ross
 2,508,868 A 5/1950 Ross
 2,510,934 A 6/1950 Schildknecht
 2,585,255 A 2/1952 Kochner et al.
 2,600,281 A 6/1952 Sticelber
 2,664,002 A 12/1953 Anderson
 D173,029 S 9/1954 Green et al.
 2,693,210 A 11/1954 Gustafson
 2,699,737 A 1/1955 Sticelber
 2,722,114 A 11/1955 Kochner
 2,759,830 A 8/1956 Touceda
 2,794,627 A 6/1957 Rodwick
 D181,157 S * 10/1957 Mad D7/372
 2,905,452 A 9/1959 Appleton
 D186,728 S 11/1959 Talge
 2,946,299 A 7/1960 Clifford
 2,965,145 A 12/1960 Gufffreund
 D192,704 S 5/1962 Giunta
 3,180,627 A 4/1965 Belonga
 3,211,202 A 10/1965 Mason
 3,220,450 A 11/1965 Aronson, II et al.
 3,268,342 A 8/1966 Yatuni
 3,353,308 A * 11/1967 Zane B24D 11/00
 451/529

3,357,469 A 12/1967 Pease et al.
 3,414,925 A * 12/1968 Stavors B02C 18/34
 15/104.001
 3,440,150 A 4/1969 Kramer et al.
 RE26,684 E 10/1969 Mason
 D222,209 S * 10/1971 Dykes D7/372
 3,635,147 A 1/1972 Lee
 3,838,023 A 9/1974 Friedemann
 D233,123 S 10/1974 Rigamonti
 3,883,283 A 5/1975 Herrera
 D236,283 S 8/1975 McCue
 D236,425 S 8/1975 McCue
 3,952,621 A 4/1976 Chambos
 3,956,517 A 5/1976 Curry et al.
 3,960,369 A 6/1976 Sommer
 4,078,481 A 3/1978 Wunderlin
 4,083,756 A 4/1978 Tajkowski
 4,213,569 A 7/1980 Amiot
 4,216,917 A 8/1980 Clare et al.
 4,234,605 A 11/1980 Takeuchi
 4,277,181 A 7/1981 Stahly et al.
 D260,351 S 8/1981 Shun
 4,332,539 A 6/1982 Zani
 4,337,000 A 6/1982 Lehmann
 4,348,166 A 9/1982 Fowler
 4,390,133 A 6/1983 Wanat
 4,406,603 A * 9/1983 Williams A47J 43/06
 241/101.1
 4,429,624 A 2/1984 Linn
 D276,202 S 11/1984 Shun
 4,487,509 A 12/1984 Boyce
 4,512,522 A 4/1985 Williams
 4,569,851 A 2/1986 Schultz
 4,581,990 A 4/1986 Matsumoto
 4,619,192 A 10/1986 Cycyk et al.
 4,628,808 A 12/1986 Simon
 4,649,810 A 3/1987 Wong
 4,693,610 A 9/1987 Weiss
 4,704,959 A 11/1987 Scallen
 4,714,203 A 12/1987 Williams
 4,770,619 A 9/1988 Rijkaart
 D300,400 S 3/1989 Kelly et al.
 4,817,512 A 4/1989 Vangen
 4,820,054 A 4/1989 Wong
 4,854,717 A 8/1989 Crane et al.
 4,878,627 A 11/1989 Otto
 4,942,807 A 7/1990 Wong
 4,959,517 A 9/1990 Jump et al.
 4,984,512 A 1/1991 Takahashi et al.
 5,022,315 A 6/1991 Bertram et al.
 5,054,383 A 10/1991 Cho
 5,091,046 A 2/1992 Hunter et al.
 5,272,961 A 12/1993 Campbell et al.
 5,289,760 A 3/1994 Barradas
 5,302,021 A 4/1994 Jennett et al.
 5,363,746 A 11/1994 Gordon
 5,402,710 A 4/1995 Chen
 D362,597 S 9/1995 Kim
 5,460,506 A 10/1995 Price, IV et al.
 5,463,937 A 11/1995 Belongia et al.
 5,469,782 A 11/1995 Wong
 5,470,599 A 11/1995 Ruhe
 5,486,100 A 1/1996 Hsu
 5,486,665 A 1/1996 Le Rouzic
 5,493,955 A 2/1996 Belongia et al.
 5,513,557 A 5/1996 Chiang
 D370,383 S 6/1996 Brefka
 D372,650 S 8/1996 Bundy
 5,558,011 A 9/1996 Heim
 D376,736 S 12/1996 Kim
 5,662,032 A 9/1997 Baratta
 5,690,022 A 11/1997 Chai
 5,758,963 A 6/1998 Xie et al.
 5,770,239 A 6/1998 Ancona
 5,771,784 A 6/1998 Sham
 5,786,016 A 7/1998 Campbell et al.
 5,816,136 A 10/1998 Stallings
 5,823,675 A 10/1998 Myerly
 5,839,356 A 11/1998 Dornbush et al.

(56)

References Cited

U.S. PATENT DOCUMENTS

RE36,155 E 3/1999 Scallen
 5,878,643 A 3/1999 Hwang
 5,919,493 A 7/1999 Sheppard et al.
 5,935,656 A 8/1999 Koemer et al.
 5,950,528 A 9/1999 Wang
 5,957,045 A 9/1999 He et al.
 D414,983 S 10/1999 Wong
 6,024,554 A 2/2000 Lawrence
 6,035,766 A 3/2000 Schirmer
 6,053,098 A 4/2000 Yamamoto
 6,113,966 A 9/2000 Belongia et al.
 6,148,169 A 11/2000 Tsukamoto
 6,163,095 A 12/2000 Shams et al.
 6,188,046 B1 2/2001 Barrow
 D444,669 S 7/2001 Prot
 6,259,068 B1 7/2001 Barrow
 6,270,826 B1 8/2001 Kashulines, Jr. et al.
 6,297,479 B1 10/2001 Wefers
 6,321,641 B1 11/2001 Wang
 6,373,031 B1 4/2002 Barrow
 6,442,866 B2 9/2002 Wefers
 D467,485 S * 12/2002 Daniels D15/140
 D475,253 S 6/2003 Yip
 6,609,455 B2 8/2003 Fouquet
 D480,613 S * 10/2003 Wong D7/384
 D484,738 S 1/2004 Wong
 6,698,338 B2 3/2004 Ancona et al.
 6,718,852 B1 4/2004 Bickel et al.
 6,743,007 B2 6/2004 Backus et al.
 D495,921 S 9/2004 Lallemand
 6,805,312 B2 10/2004 Capp
 6,854,383 B2 2/2005 Wang
 6,948,609 B2 9/2005 Finger et al.
 7,029,714 B2 4/2006 Mihalos et al.
 7,032,491 B2 4/2006 Fischer
 7,063,009 B2 6/2006 Lin
 D526,539 S 8/2006 Yip
 7,083,040 B2 8/2006 Finger et al.
 D531,850 S 11/2006 Wong
 7,169,450 B2 1/2007 Bunick
 D539,836 S 4/2007 Faber
 7,207,510 B2 4/2007 Wong
 7,238,017 B2 7/2007 Marcato
 D551,493 S 9/2007 Marcato
 D553,427 S 10/2007 Ball
 7,314,308 B2 1/2008 Fallowes et al.
 7,318,666 B1 1/2008 Lin
 7,461,589 B2 12/2008 Sinton
 D601,391 S 10/2009 Chiang
 7,648,264 B2 1/2010 Breviere et al.
 D610,396 S 2/2010 Chiang
 7,775,705 B2 8/2010 Kozlowski et al.
 7,827,906 B1 11/2010 Carter
 7,887,314 B2 2/2011 Ruhe et al.
 D643,265 S 8/2011 Kim et al.
 7,993,694 B2 8/2011 Goderiaux et al.
 8,122,821 B2 2/2012 Sands
 8,162,653 B2 4/2012 Marcato
 D660,660 S 5/2012 Kim
 8,172,454 B2 5/2012 Choi
 8,210,737 B2 7/2012 Wong
 D666,056 S 8/2012 Boozer et al.
 D669,324 S 10/2012 Bodum
 D670,138 S 11/2012 Hu
 D677,975 S 3/2013 Jin et al.
 D682,651 S * 5/2013 McRoberts D8/70
 8,438,971 B1 5/2013 Thurley
 D683,577 S 6/2013 Cohen
 D684,827 S 6/2013 Kim
 D698,210 S 1/2014 Lavy et al.
 D699,064 S 2/2014 Katterheinrich et al.
 D712,696 S 9/2014 Huber et al.
 D715,094 S 10/2014 Cornu et al.
 D718,094 S 11/2014 Yan
 D720,967 S 1/2015 Melzer et al.

D721,548 S 1/2015 Jin
 D721,549 S 1/2015 Li
 D725,440 S 3/2015 Kim
 D747,916 S 1/2016 Wong
 D763,035 S 8/2016 Hume
 9,474,419 B2 10/2016 Schneider
 9,500,235 B2 11/2016 Kanning
 D775,491 S 1/2017 Brinkley et al.
 D776,494 S 1/2017 Carr et al.
 D790,918 S 7/2017 Benoit et al.
 9,775,467 B2 10/2017 Sapire
 D811,158 S 2/2018 Yuan
 D861,447 S * 10/2019 Strickland D8/32
 D867,051 S 11/2019 McConnell et al.
 D868,530 S 12/2019 Zhan
 D878,146 S 3/2020 McConnell et al.
 D885,822 S 6/2020 McConnell et al.
 D891,853 S 8/2020 McConnell et al.
 2001/0019778 A1 9/2001 Gardaz et al.
 2001/0028909 A1 10/2001 Kashulines, Jr. et al.
 2001/0032856 A1 10/2001 Casey
 2002/0006464 A1 1/2002 Wefers
 2002/0181322 A1 12/2002 Brunswick et al.
 2004/0001387 A1 1/2004 Haller et al.
 2004/0145965 A1 7/2004 Chan et al.
 2005/0058018 A1 3/2005 Hooper et al.
 2005/0120888 A1 6/2005 Wang
 2005/0257692 A1 11/2005 Marcato
 2006/0044935 A1 3/2006 Benelli et al.
 2006/0117961 A1 6/2006 Guo
 2006/0254429 A1 11/2006 Sinton
 2007/0001040 A1 * 1/2007 Walters B02C 18/362
 241/82.5
 2008/0213447 A1 9/2008 Payen et al.
 2008/0271609 A1 11/2008 Pahl et al.
 2009/0090254 A1 4/2009 Herren
 2009/0120301 A1 5/2009 Severnak
 2009/0129200 A1 5/2009 Breviere et al.
 2009/0310436 A1 12/2009 Huang et al.
 2010/0012639 A1 1/2010 Merrell et al.
 2010/0028514 A1 2/2010 Goderiaux et al.
 2010/0147160 A1 6/2010 Oochi
 2010/0196529 A1 8/2010 Marcato
 2010/0202244 A1 8/2010 Choi
 2010/0308142 A1 12/2010 Krasznai et al.
 2011/0017750 A1 1/2011 Fortkamp
 2011/0063941 A1 3/2011 Seidler et al.
 2011/0185917 A1 8/2011 Goderiaux et al.
 2011/0214574 A1 9/2011 Chang
 2011/0248108 A1 10/2011 Carriere
 2012/0042786 A1 2/2012 Fedell
 2012/0138716 A1 6/2012 Taguchi et al.
 2012/0227592 A1 9/2012 Lim et al.
 2013/0074700 A1 3/2013 Cheung
 2014/0133263 A1 5/2014 Schneider
 2015/0000534 A1 1/2015 Hager et al.
 2015/0098299 A1 4/2015 Sapire
 2015/0201787 A1 7/2015 Holzbauer et al.
 2015/0208853 A1 7/2015 Melzer et al.
 2015/0238042 A1 8/2015 Tonelli et al.
 2016/0143484 A1 5/2016 Palmer et al.
 2016/0332166 A1 11/2016 Chen
 2018/0099289 A1 4/2018 Moore et al.

FOREIGN PATENT DOCUMENTS

EP 0405636 B1 9/1993
 EP 1230857 A1 8/2002
 EP 1430824 A1 6/2004
 EP 2269491 A1 1/2011
 EP 2508110 A1 10/2012
 FR 2447703 8/1980
 FR 2939298 A1 6/2010
 JP 2010029103 A 2/2010
 WO 9415511 A1 7/1994

(56)

References Cited

FOREIGN PATENT DOCUMENTS

WO 2009016465 A2 2/2009
WO 2009141699 A2 11/2009

OTHER PUBLICATIONS

Charles A. Grubbs; "Anodizing of Aluminum"; Consultant, Alpharetta, GA.; pp. 478-493; date unknown.

* cited by examiner

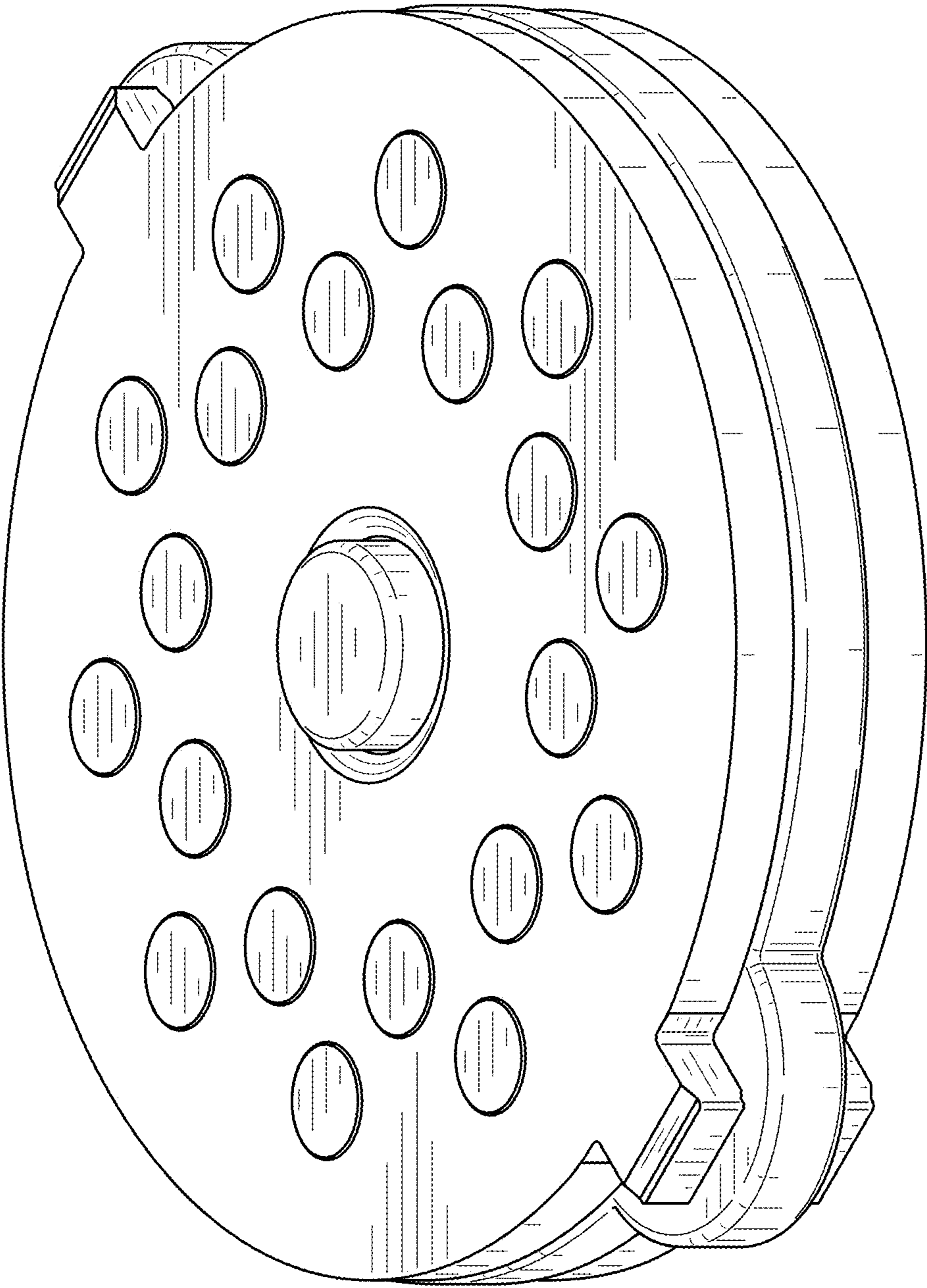

FIG. 1

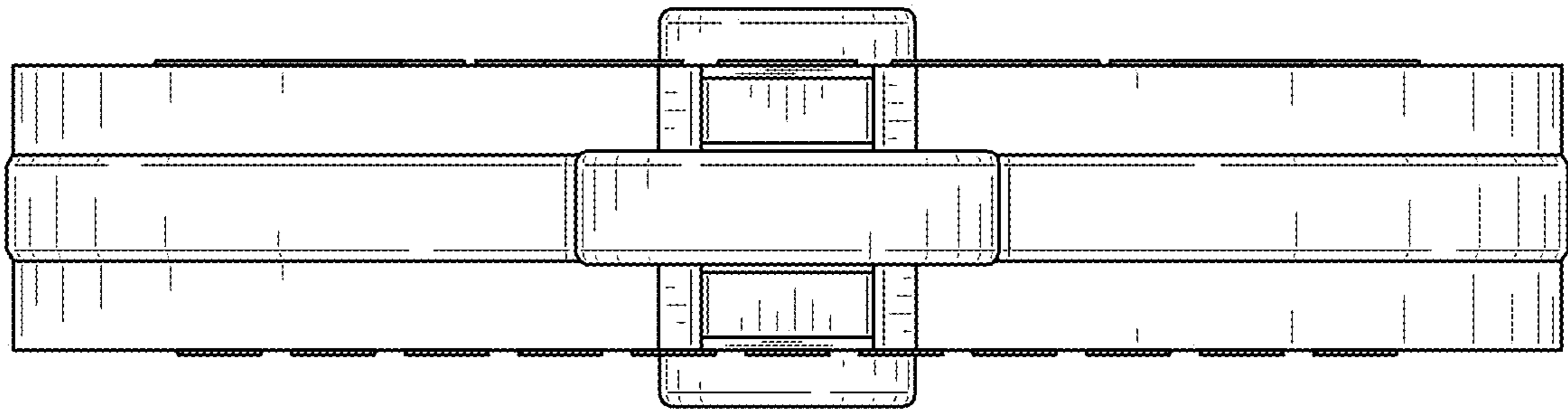

FIG. 2

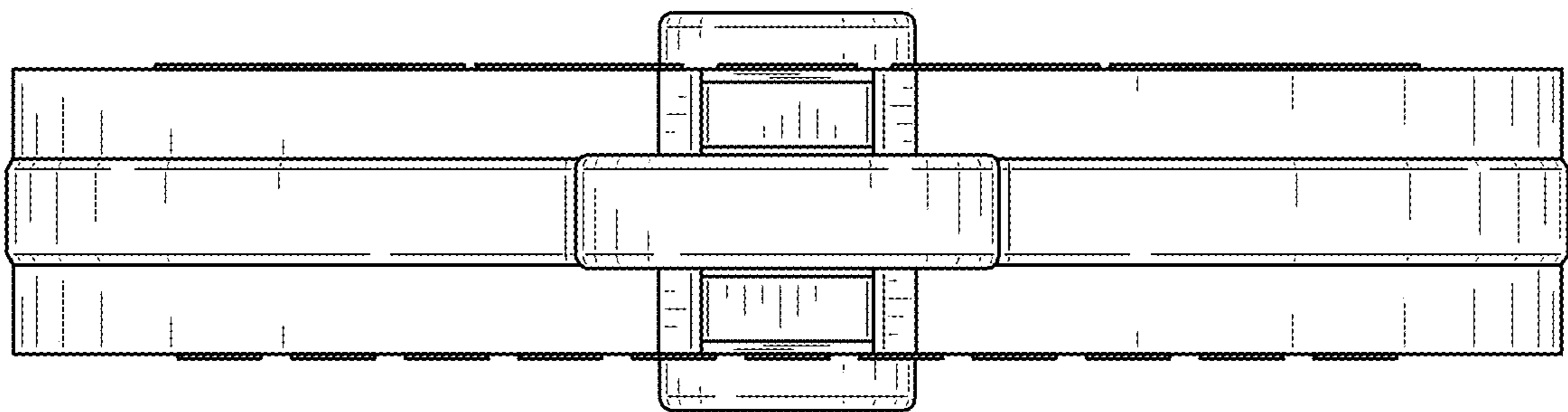

FIG. 3

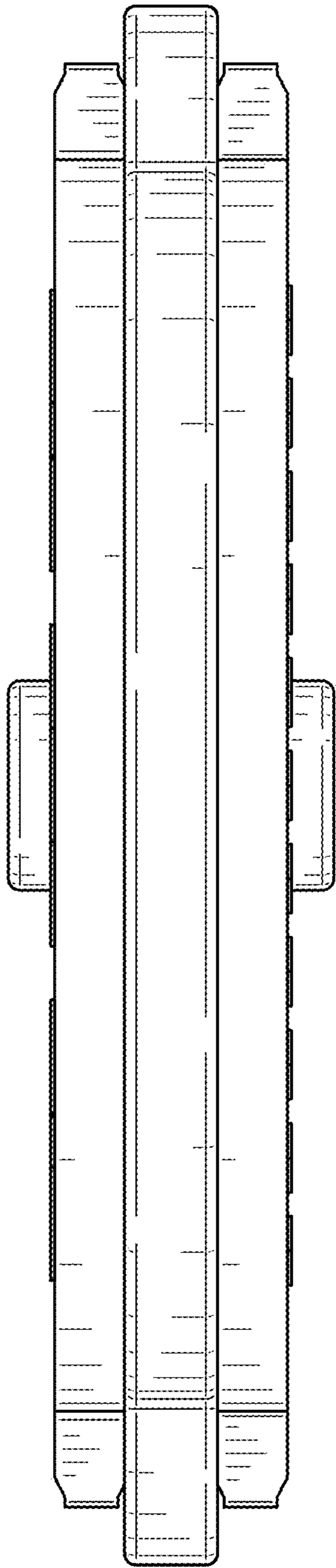

FIG. 4

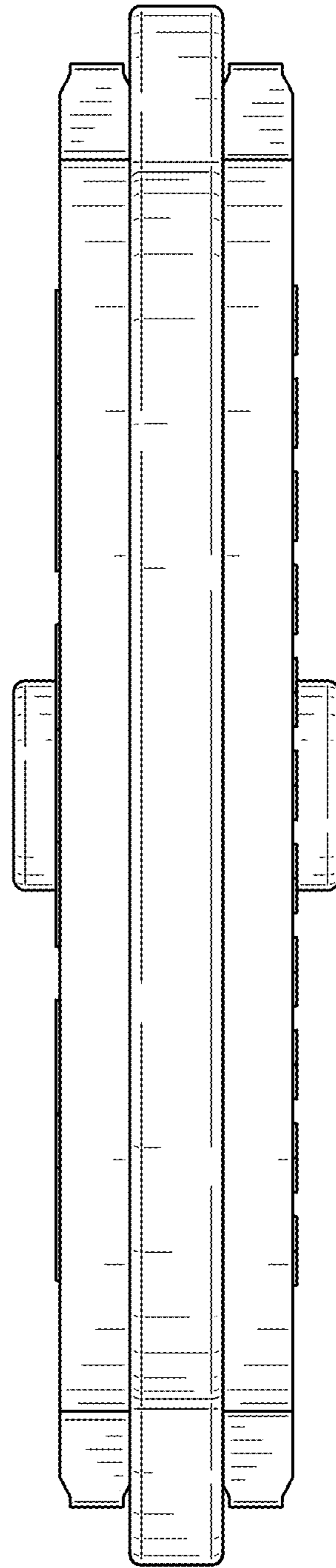

FIG. 5

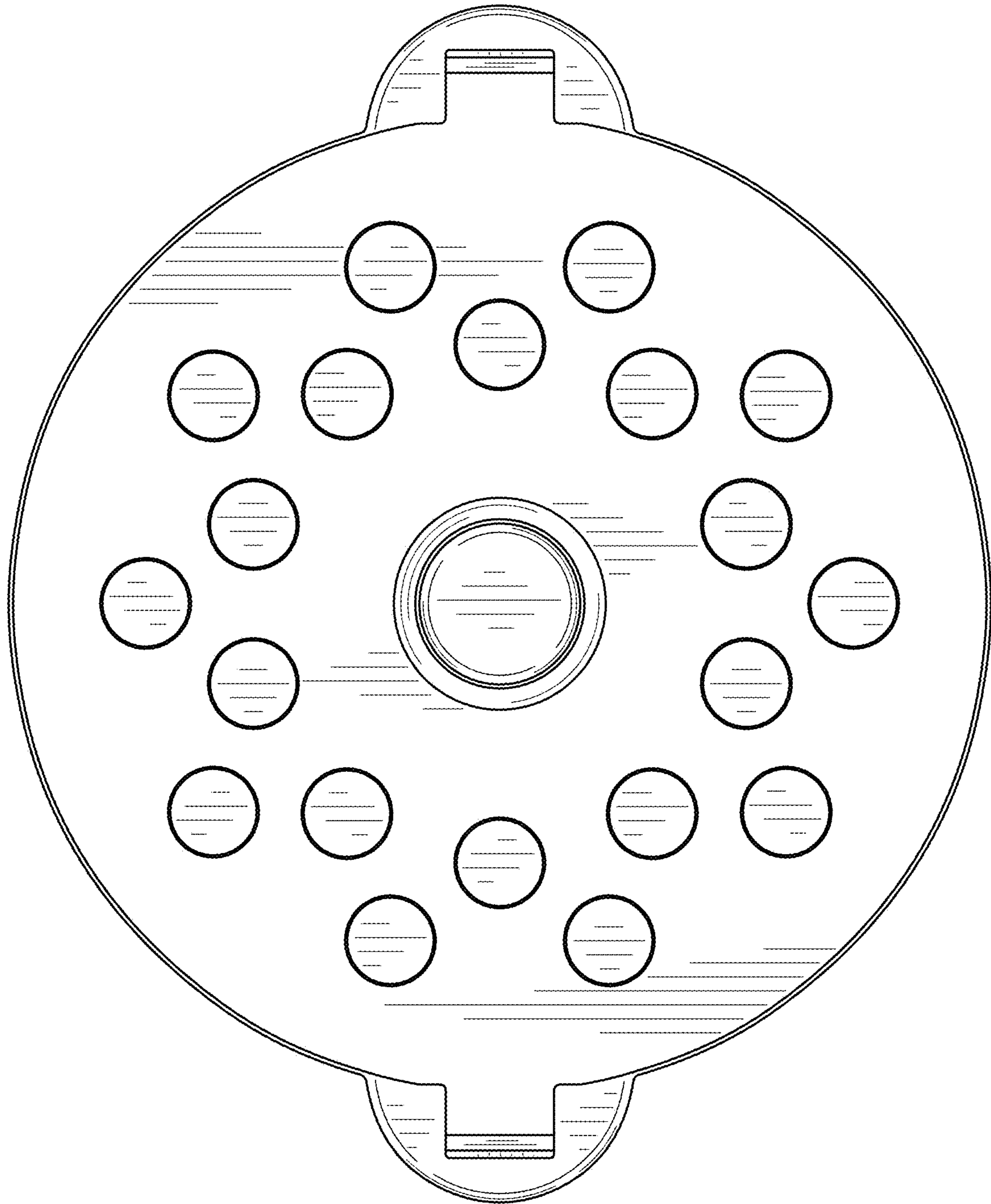

FIG. 6

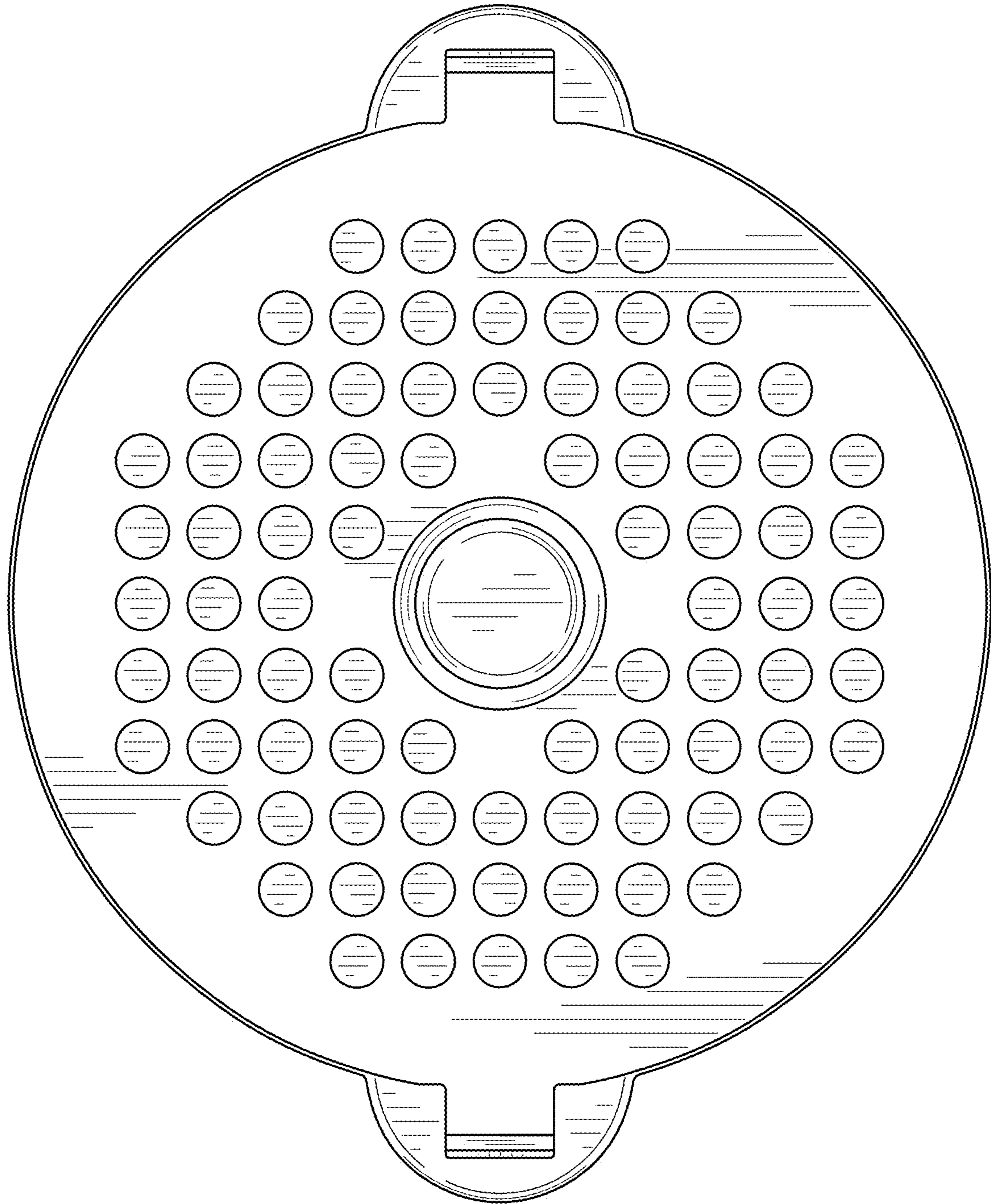

FIG. 7