



US00D926865S

(12) **United States Design Patent** (10) **Patent No.:** **US D926,865 S**
Young (45) **Date of Patent:** **** Aug. 3, 2021**

(54) **GOGGLES**

(71) Applicant: **100% SPEEDLAB, LLC**, San Diego, CA (US)

(72) Inventor: **Michael D. Young**, San Diego, CA (US)

(73) Assignee: **100% Speedlab, LLC**, San Diego, CA (US)

(**) Term: **15 Years**

(21) Appl. No.: **29/739,515**

(22) Filed: **Jun. 25, 2020**

Related U.S. Application Data

(63) Continuation of application No. 29/719,171, filed on Dec. 31, 2019.

(51) **LOC (13) Cl.** **16-06**

(52) **U.S. Cl.**
USPC **D16/313**

(58) **Field of Classification Search**
USPC D16/300, 309, 311-314, 315, 321, 325
CPC . G02C 5/126; G02C 7/10; G02C 1/02; G02C 7/088

See application file for complete search history.

(56) **References Cited**

U.S. PATENT DOCUMENTS

D578,562 S *	10/2008	Moritz	D16/312
D640,724 S *	6/2011	Goodman	D16/312
D727,398 S *	4/2015	Blanchard	D16/312
D800,825 S *	10/2017	Frosi	D16/313
9,782,296 B2 *	10/2017	Pengfei	A61F 9/029
D828,866 S *	9/2018	Yoo	D16/313
D862,570 S *	10/2019	Frosi	D16/313
D915,499 S *	4/2021	Young	D16/330

2013/0014316 A1 *	1/2013	Castro	A41D 13/1184	2/424
2020/0306088 A1 *	10/2020	Young	A61F 9/027	
2021/0030592 A1 *	2/2021	Young	A61F 9/025	

OTHER PUBLICATIONS

Oakley 57-980 Airbrake MX Goggles, posted at amazon.com, posting date Mar. 2, 2013, [online], [site visited Apr. 28, 2021]. Available from Internet, URL: <https://www.amazon.com/Oakley-Airbrake-Goggles-Matte-White/dp/B00BNKPWRW> (Year: 2013).*
Racecraft 2 Goggle Concordia, posted at 100percent.com, posting date not given, [online], [site visited Apr. 28, 2021]. Available from Internet, URL: <https://www.100percent.com/products/racecraft-2-goggle-concordia> (Year: 2021).*

* cited by examiner

Primary Examiner — George D. Kirschbaum

Assistant Examiner — Maria J. Edwards

(74) *Attorney, Agent, or Firm* — Kolitch Romano LLP

(57) **CLAIM**

The ornamental design for goggles, as shown and described.

DESCRIPTION

FIG. 1 is a front, left and top perspective view of goggles showing the new design;
FIG. 2 is a rear, right, and bottom perspective view thereof;
FIG. 3 is a front elevational view thereof;
FIG. 4 is a rear elevational view thereof;
FIG. 5 is a top plan view thereof;
FIG. 6 is a bottom plan view thereof;
FIG. 7 is a right side elevational view thereof; and,
FIG. 8 is a left side elevational view thereof.

The dash-dash broken lines in the figures are shown for the purpose of illustrating portions of the goggles that form no part of the claimed design. The dot-dash broken lines define the bounds of the claimed design and form no part thereof.

1 Claim, 7 Drawing Sheets

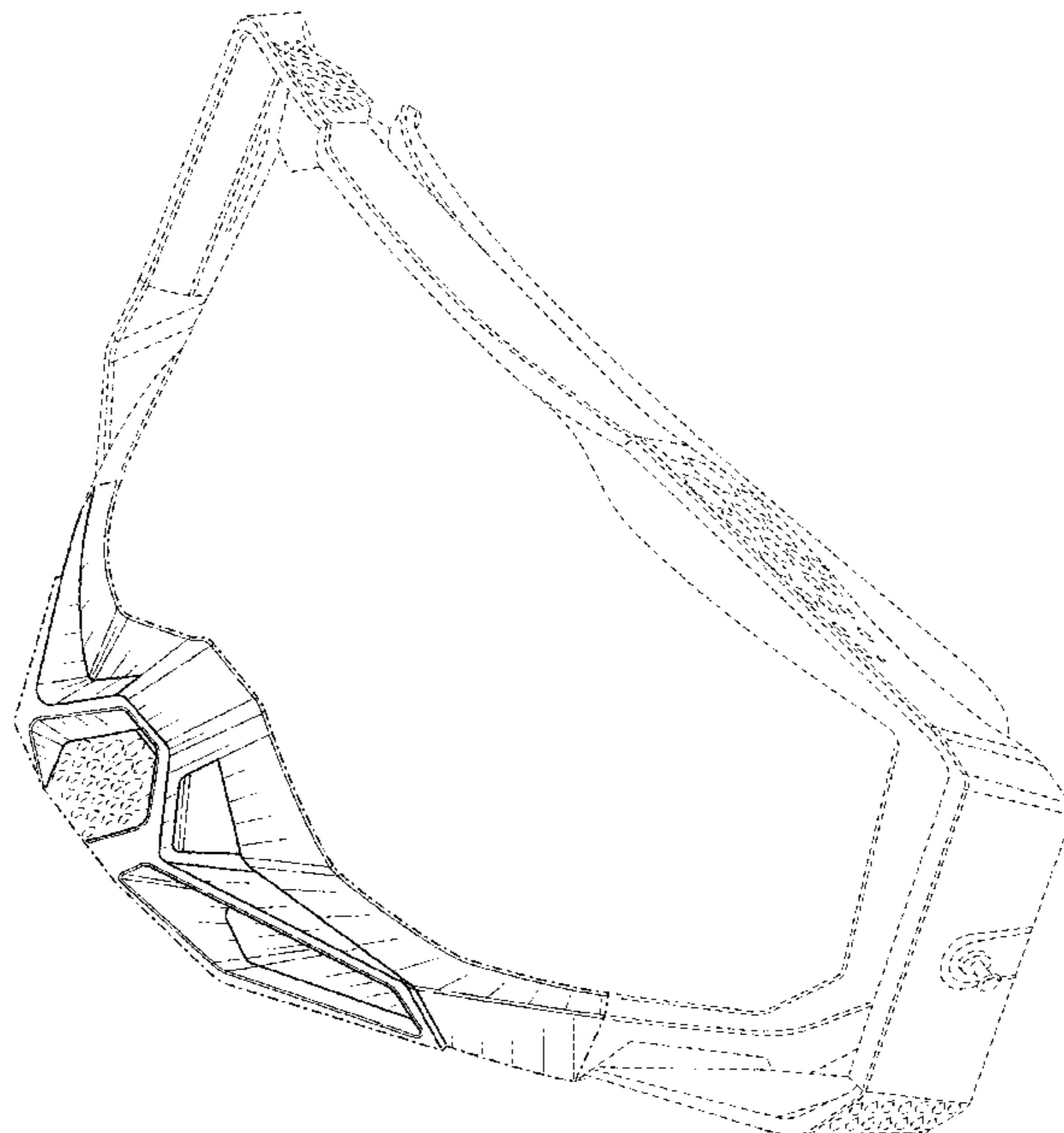

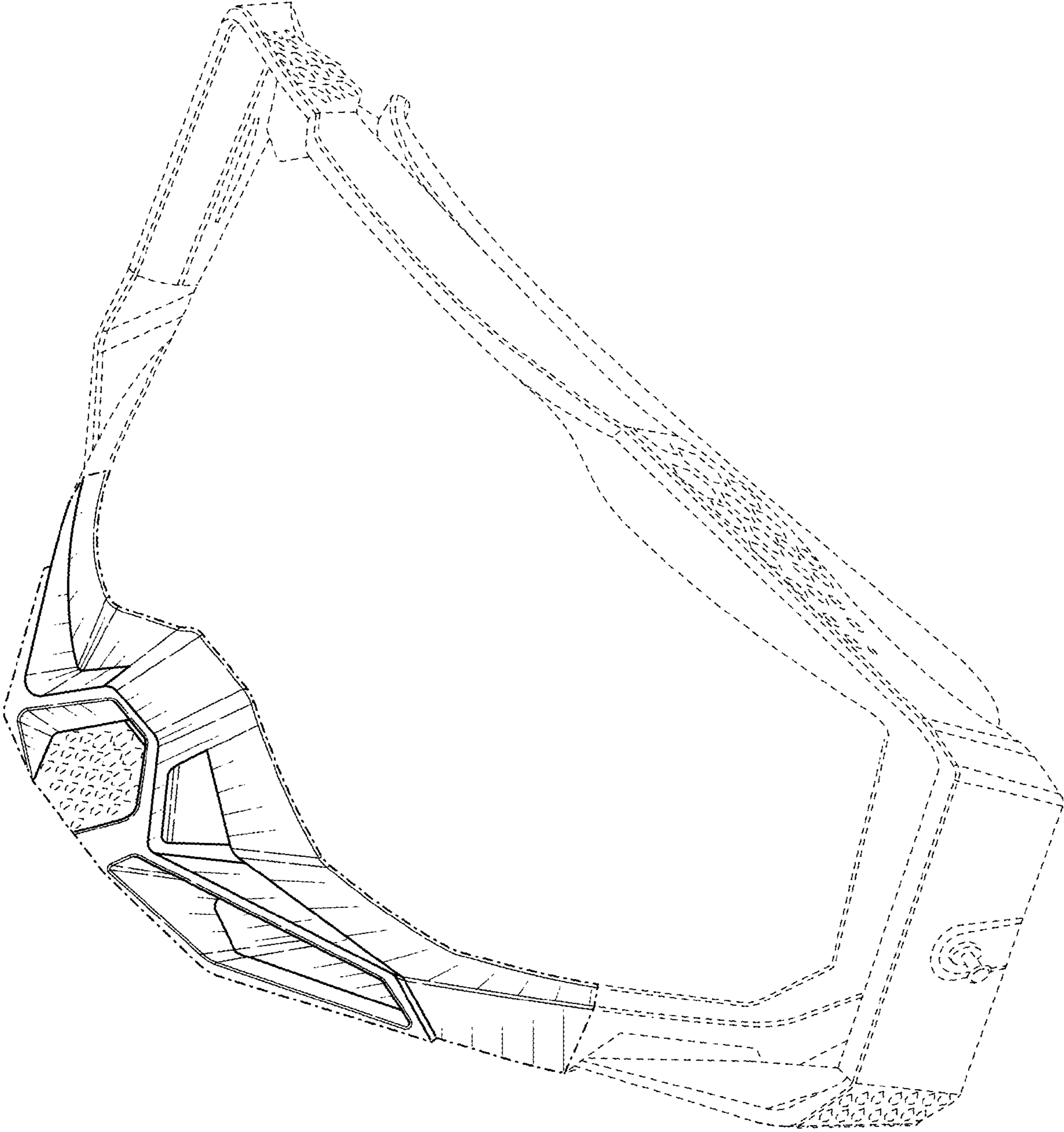

FIG. 1

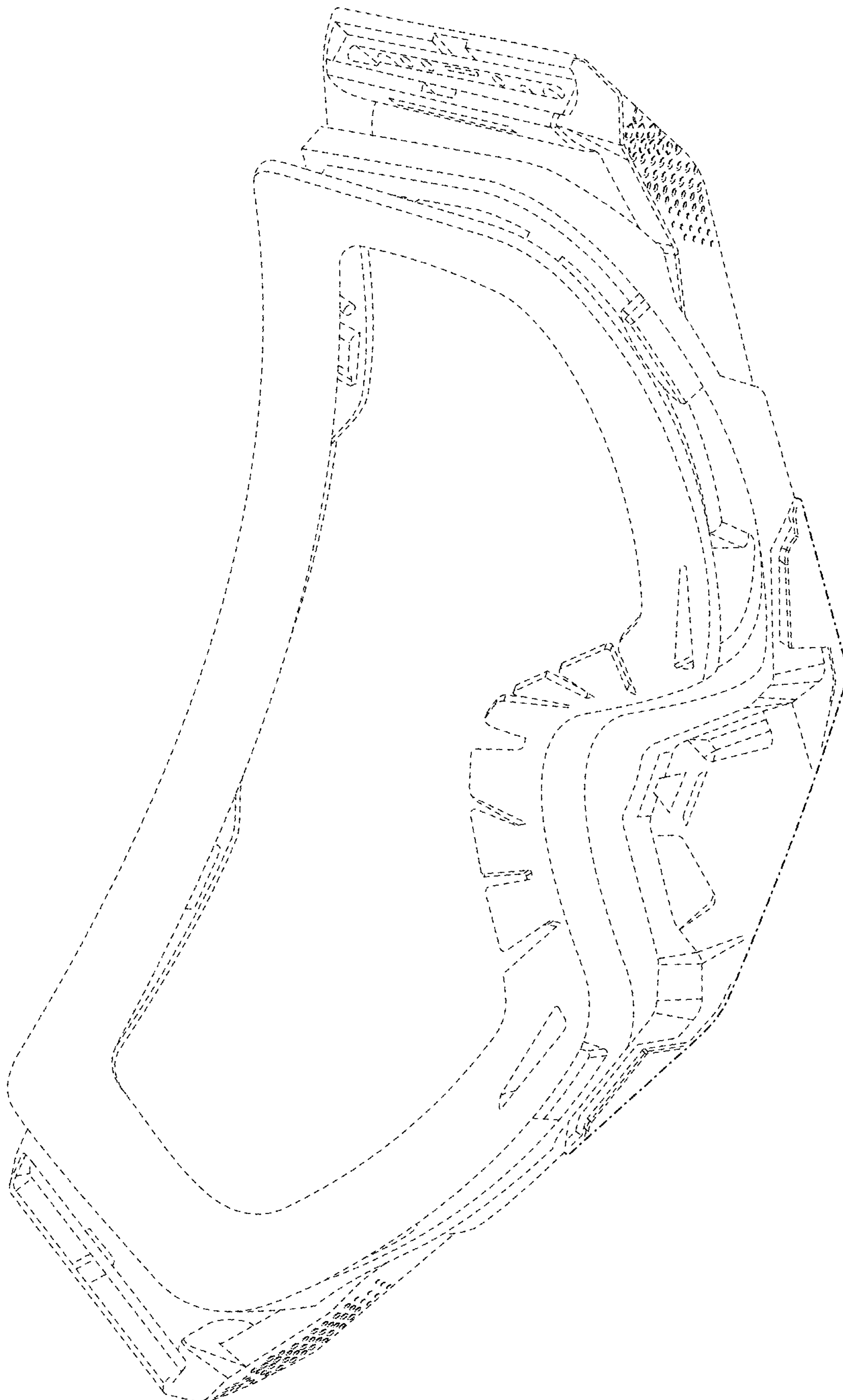

FIG. 2

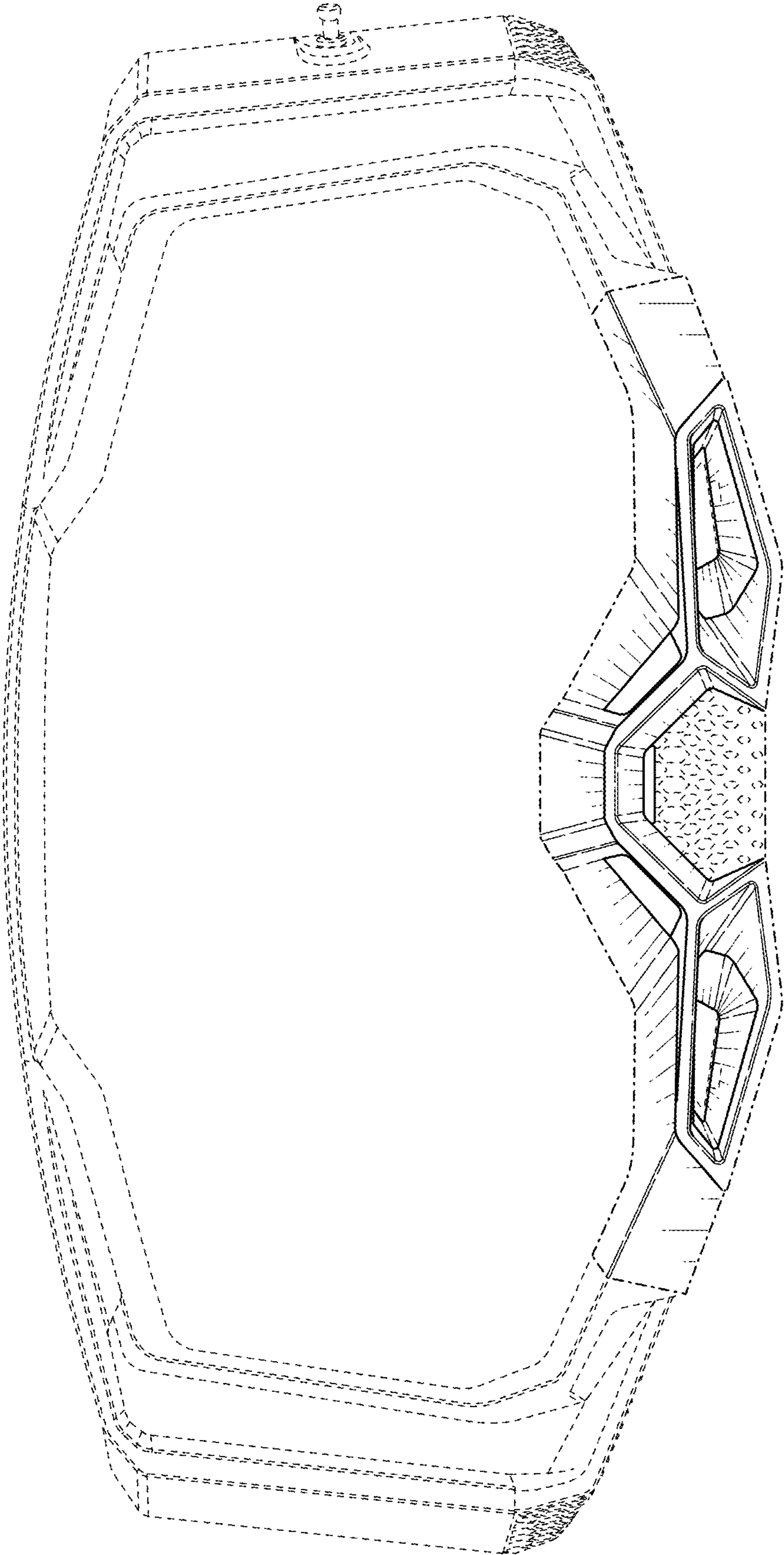

FIG. 3

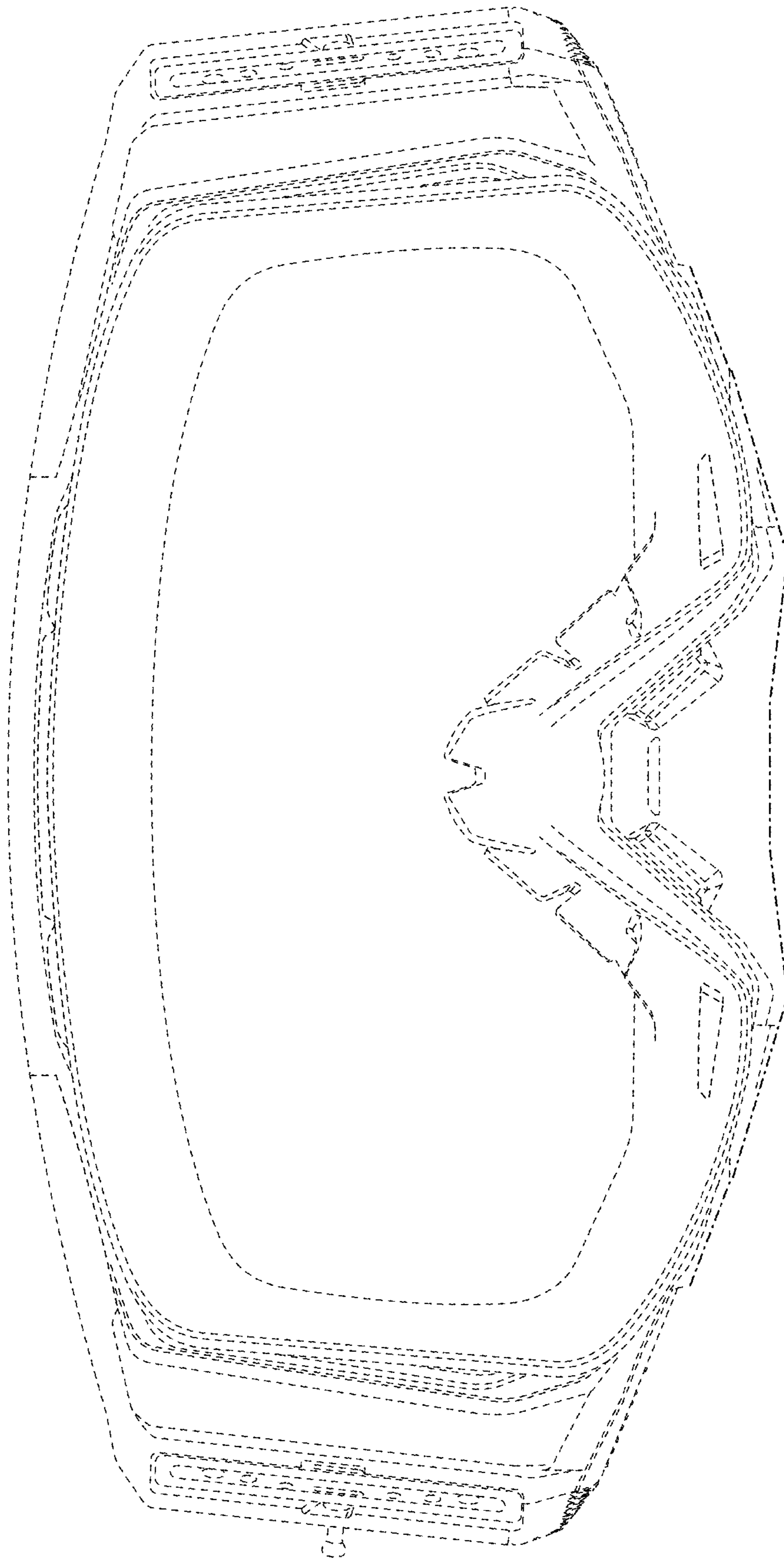

FIG. 4

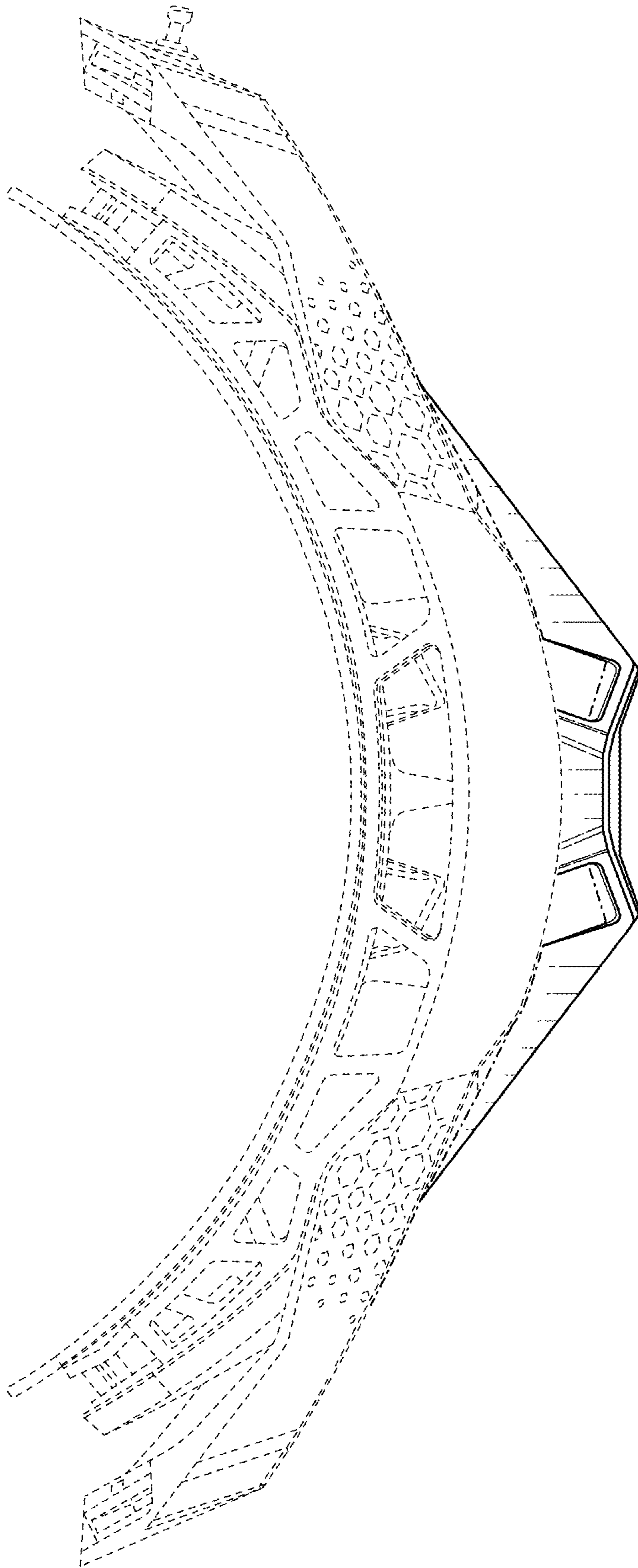

FIG. 5

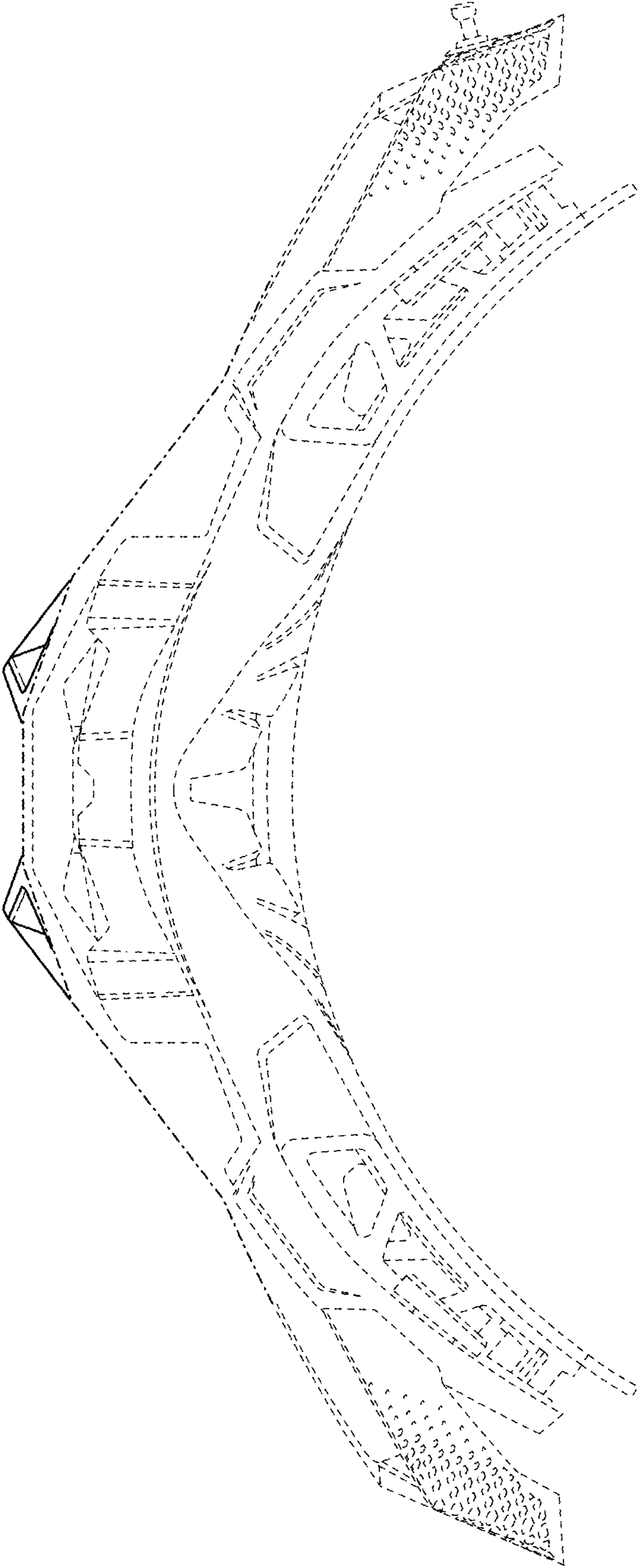

FIG. 6

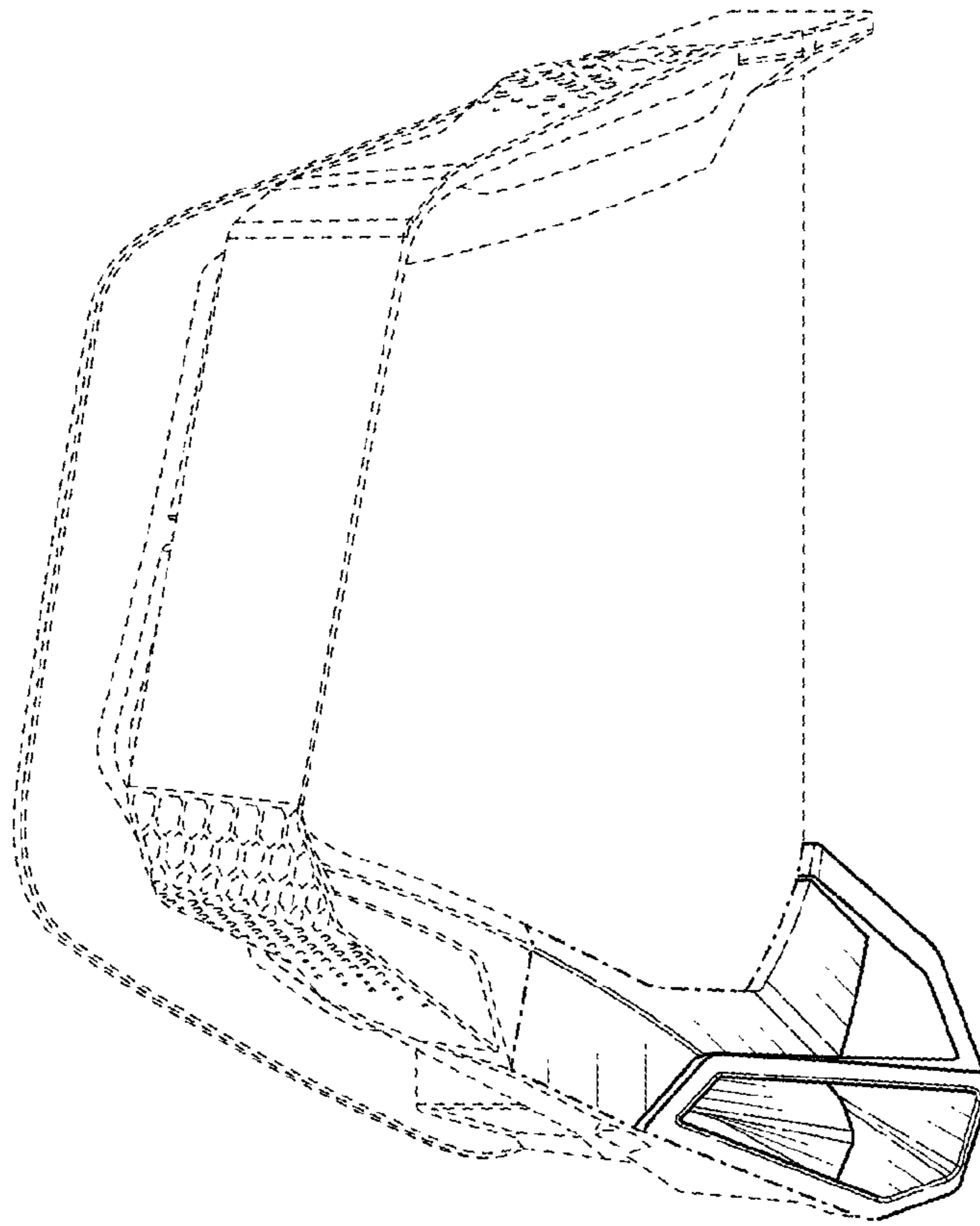

FIG. 7

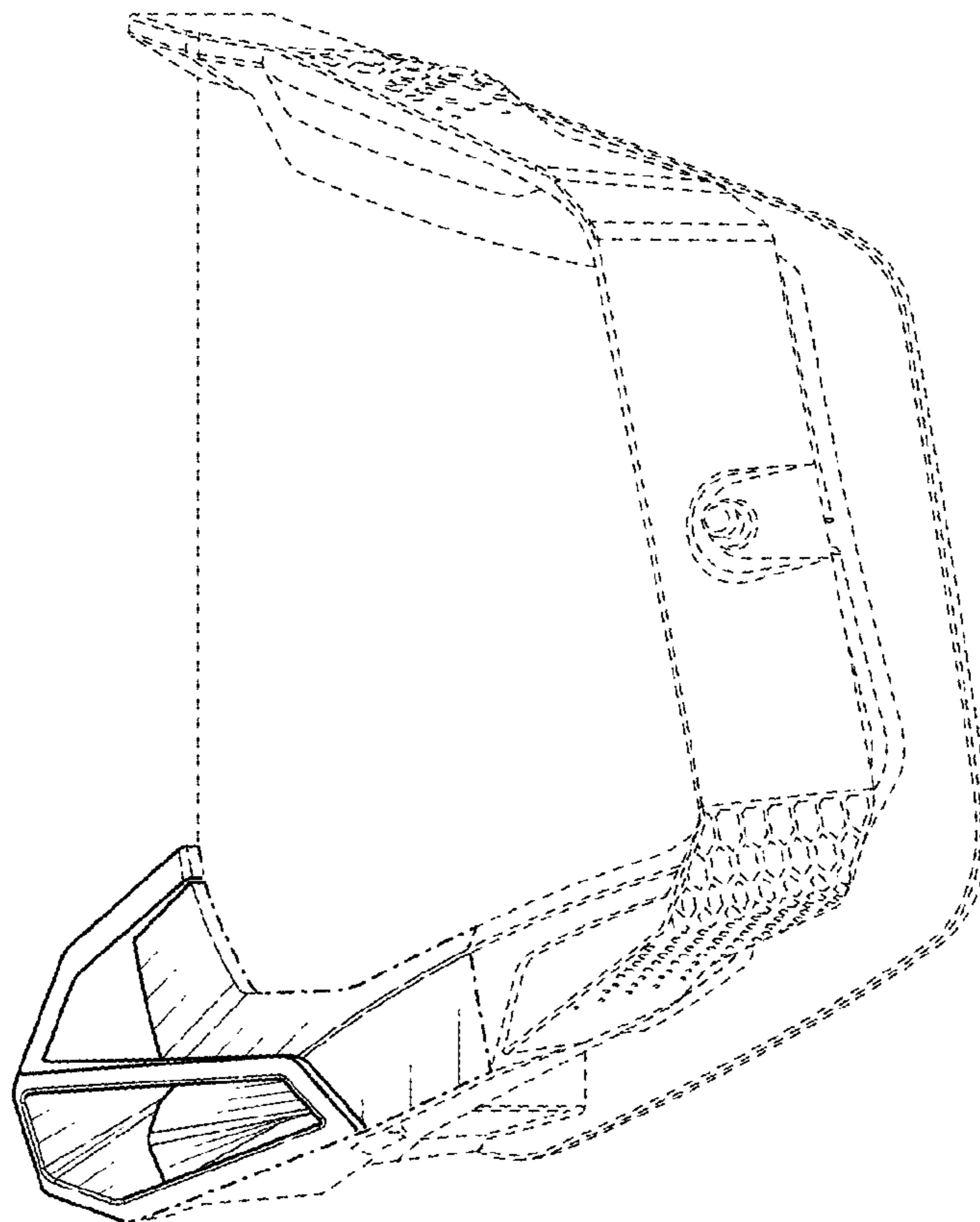

FIG. 8