



US00D926850S

(12) **United States Design Patent** (10) **Patent No.:** **US D926,850 S**
Galkin et al. (45) **Date of Patent:** **** Aug. 3, 2021**

- (54) **UPPER PLATEN FOR HEAT PRESS**
- (71) Applicant: **STAHL'S INC.**, Sterling Heights, MI (US)
- (72) Inventors: **Anton Galkin**, Carmichaels, PA (US); **Benjamin Robinson**, Carmichaels, PA (US)
- (73) Assignee: **Stahls' Inc.**, Sterling Heights, MI (US)
- (**) Term: **15 Years**
- (21) Appl. No.: **29/723,767**
- (22) Filed: **Feb. 10, 2020**

Related U.S. Application Data

- (62) Division of application No. 29/654,349, filed on Jun. 22, 2018, now Pat. No. Des. 875,148.
- (51) **LOC (13) Cl.** **15-09**
- (52) **U.S. Cl.**
USPC **D15/146; D15/122**
- (58) **Field of Classification Search**
USPC D15/122, 123, 145, 146
CPC B30B 15/04; B30B 15/18; B30B 15/048;
B30B 15/287; B32B 37/06; B32B
37/0053; B32B 2309/02
See application file for complete search history.

(56) **References Cited**

U.S. PATENT DOCUMENTS

- 1,466,714 A * 9/1923 Harnden B41F 1/22
101/3.1
- 4,257,321 A * 3/1981 Wheeler B30B 9/04
100/219
- 6,871,587 B2 * 3/2005 Kanamaru B30B 15/048
100/214
- D826,297 S * 8/2018 Yan D15/123
- D826,999 S * 8/2018 Yan D15/123

- D875,148 S * 2/2020 Galkin D15/146
- D875,149 S * 2/2020 Galkin D15/146
- 2008/0196836 A1 * 8/2008 Woods B30B 15/026
156/367
- 2012/0175813 A1 * 7/2012 Leedy A43D 95/14
264/293
- 2015/0122425 A1 * 5/2015 Hsiao B30B 1/04
156/583.1
- 2017/0314177 A1 * 11/2017 Komiya D06C 7/00

* cited by examiner

Primary Examiner — Patricia A Palasik

(74) *Attorney, Agent, or Firm* — Harness, Dickey & Pierce, PLC

(57) **CLAIM**

The ornamental design for an upper platen for heat press, as shown and described.

DESCRIPTION

FIG. 1 is a perspective view of top and left sides of an upper platen of a heat press embodying the new design;
 FIG. 2 is a front view of the upper platen of the heat press thereof;
 FIG. 3 is a right side view of the upper platen of the heat press thereof;
 FIG. 4 is a left side view of the upper platen of the heat press thereof;
 FIG. 5 is a perspective view of the bottom and left sides of an upper platen of a heat press embodying the new design;
 FIG. 6 is a bottom plan view of the upper platen of the heat press thereof;
 FIG. 7 is a rear plan view of the upper platen of the heat press thereof; and,
 FIG. 8 is a top plan view of the upper platen of the heat press thereof.

The broken lines show features of the heat press that form no part of the claimed designs of FIGS. 1 through 8.

1 Claim, 3 Drawing Sheets

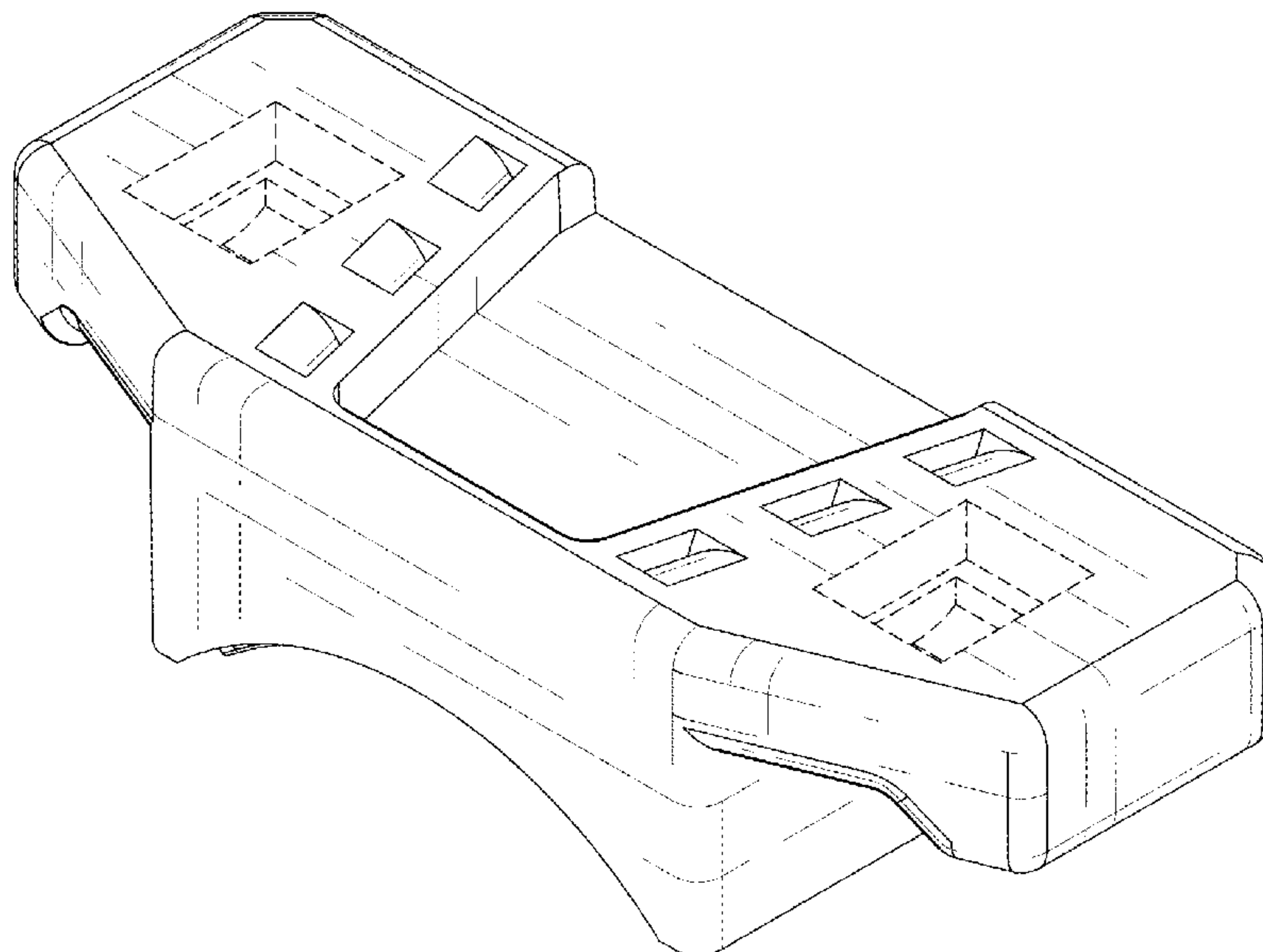

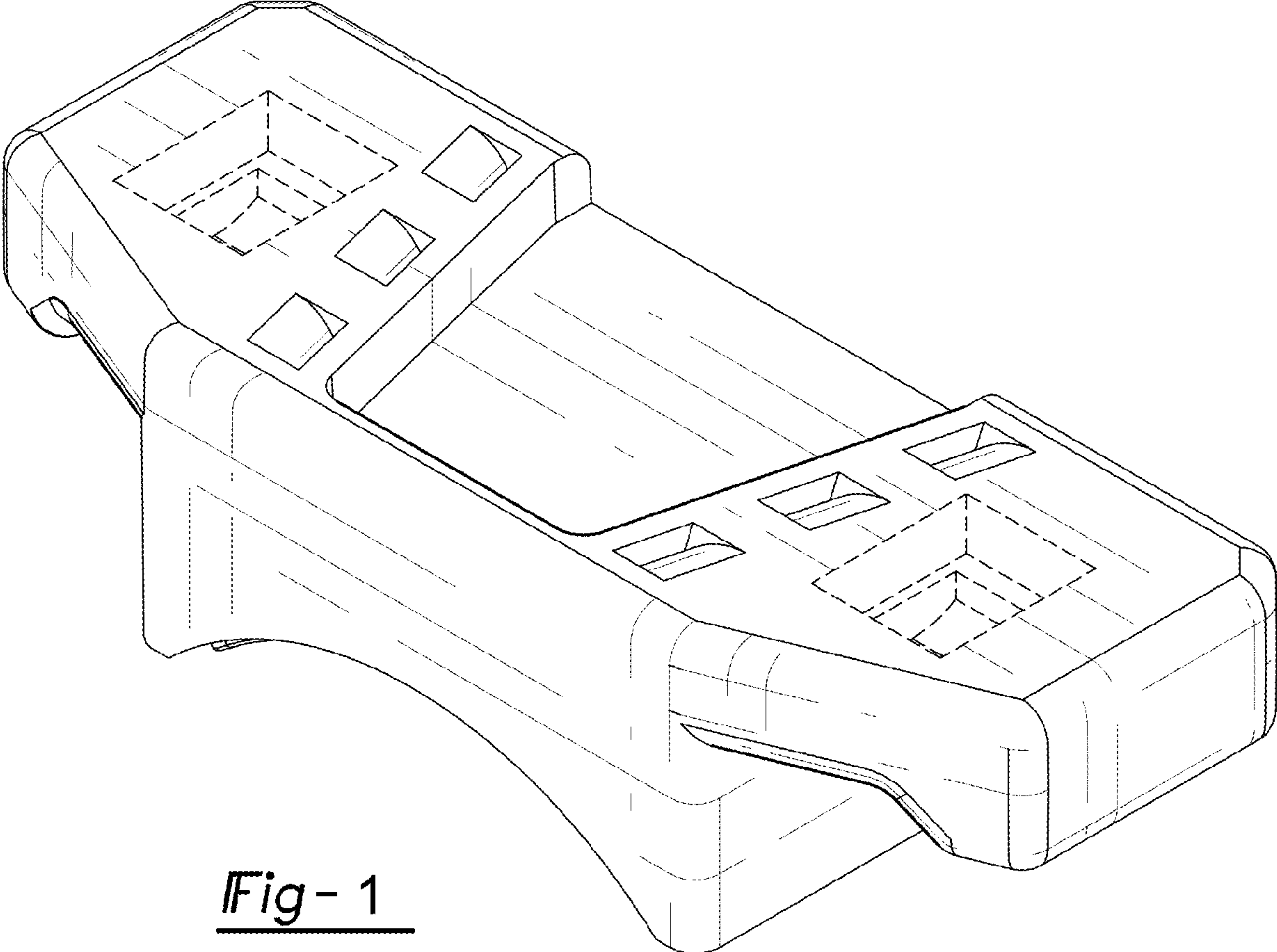

Fig-1

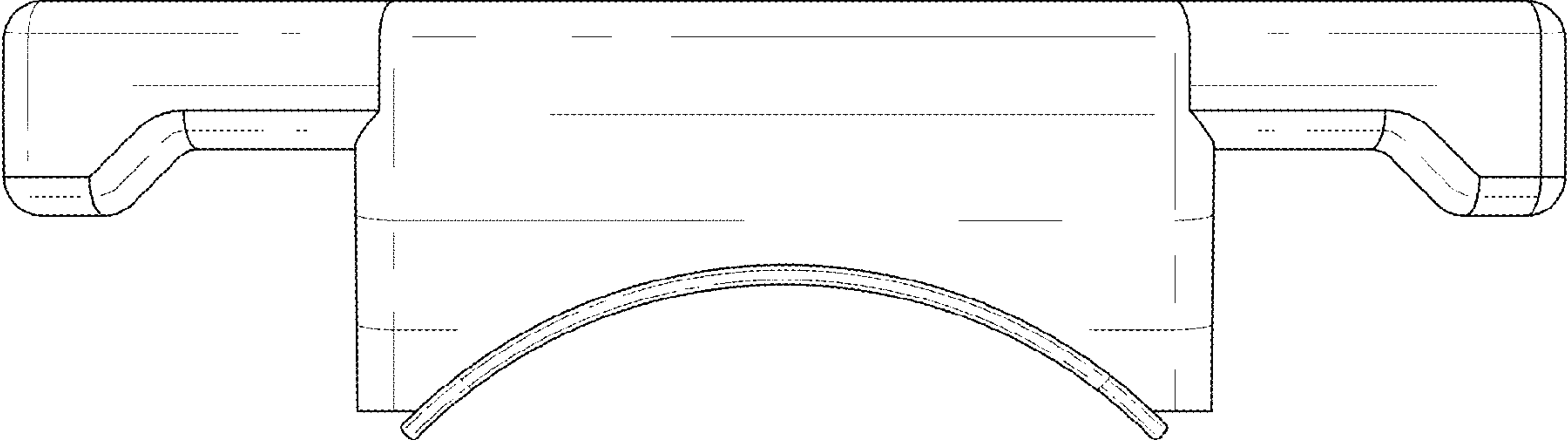

Fig-2

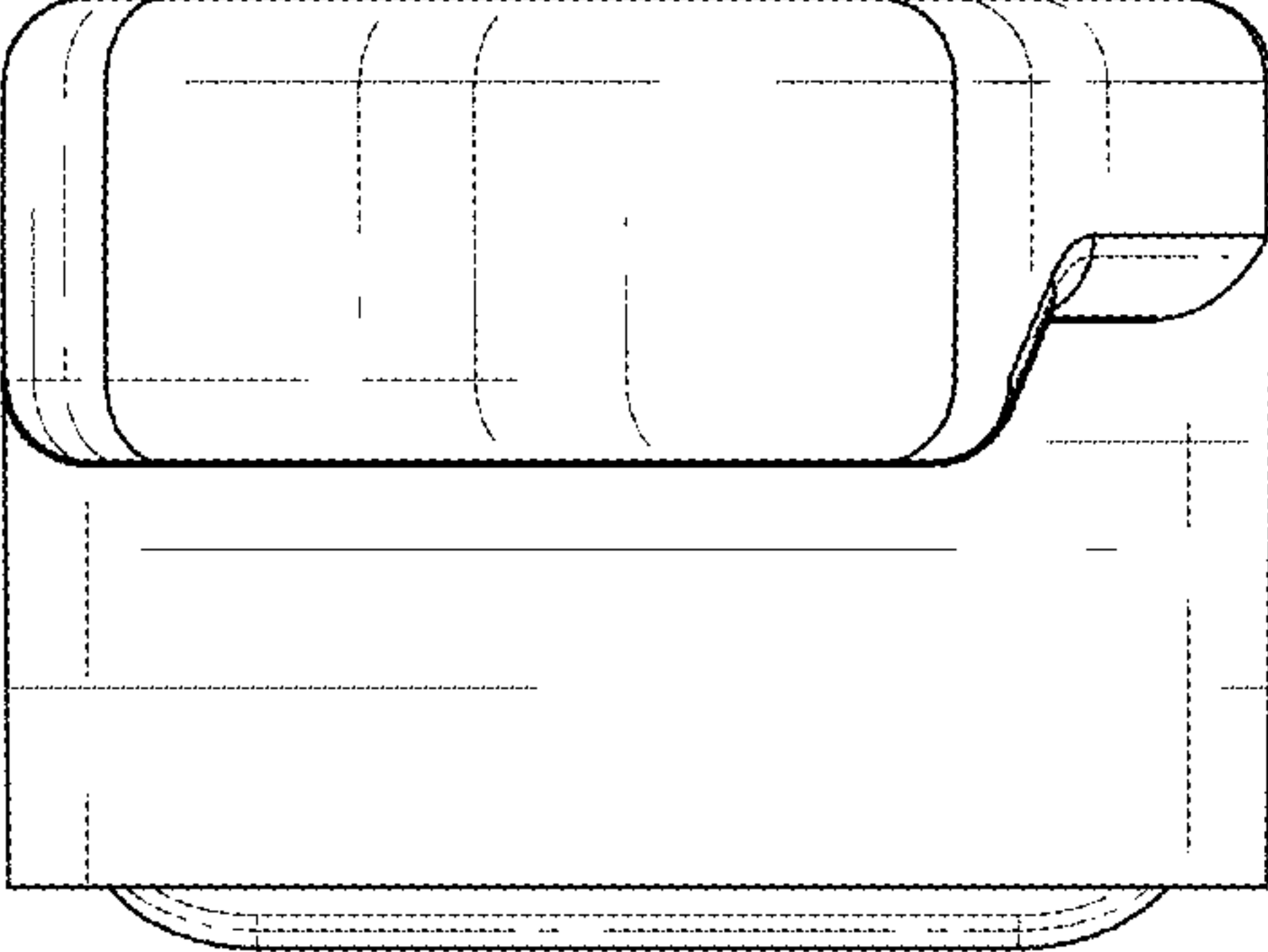

Fig-3

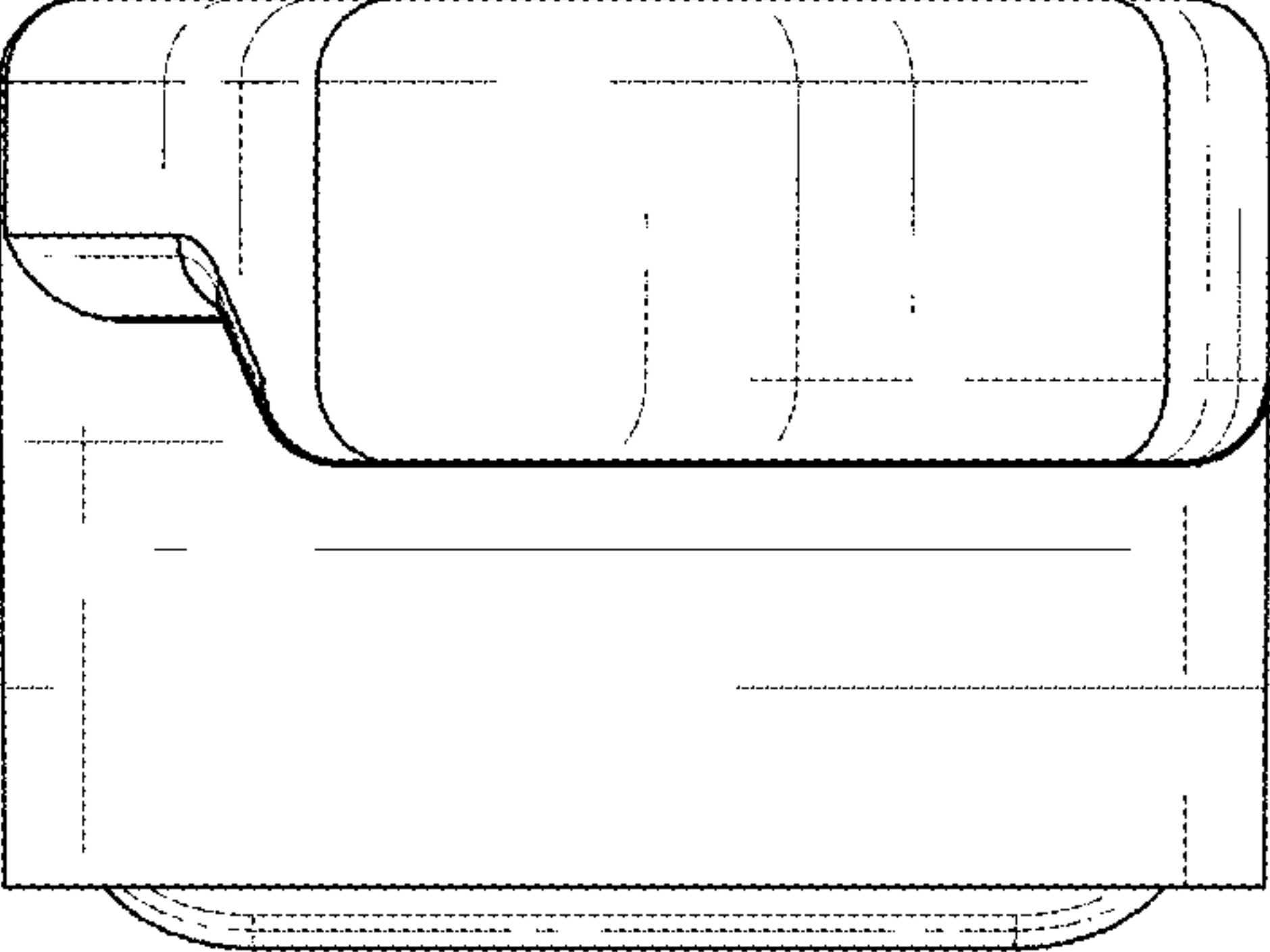

Fig-4

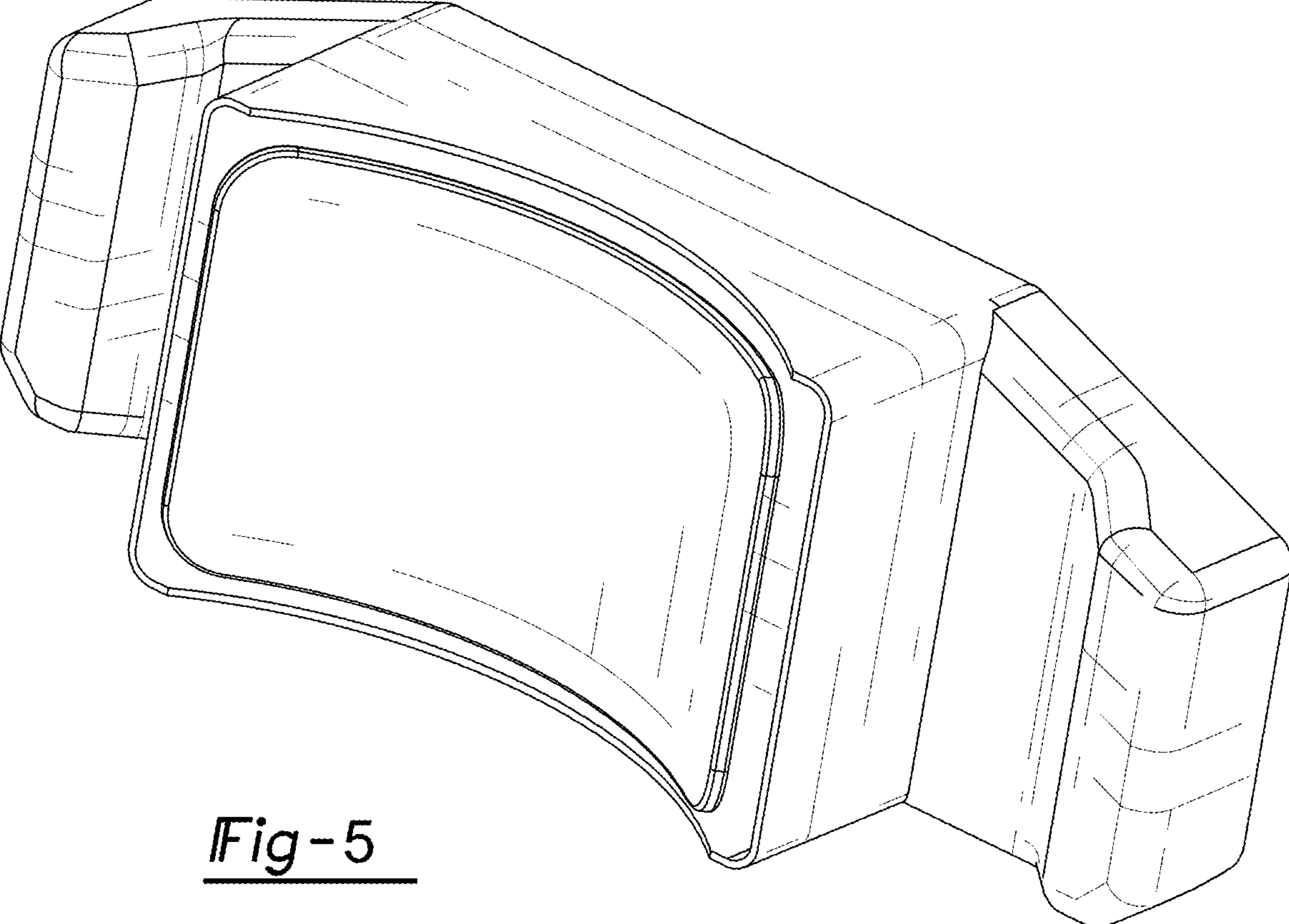

Fig-5

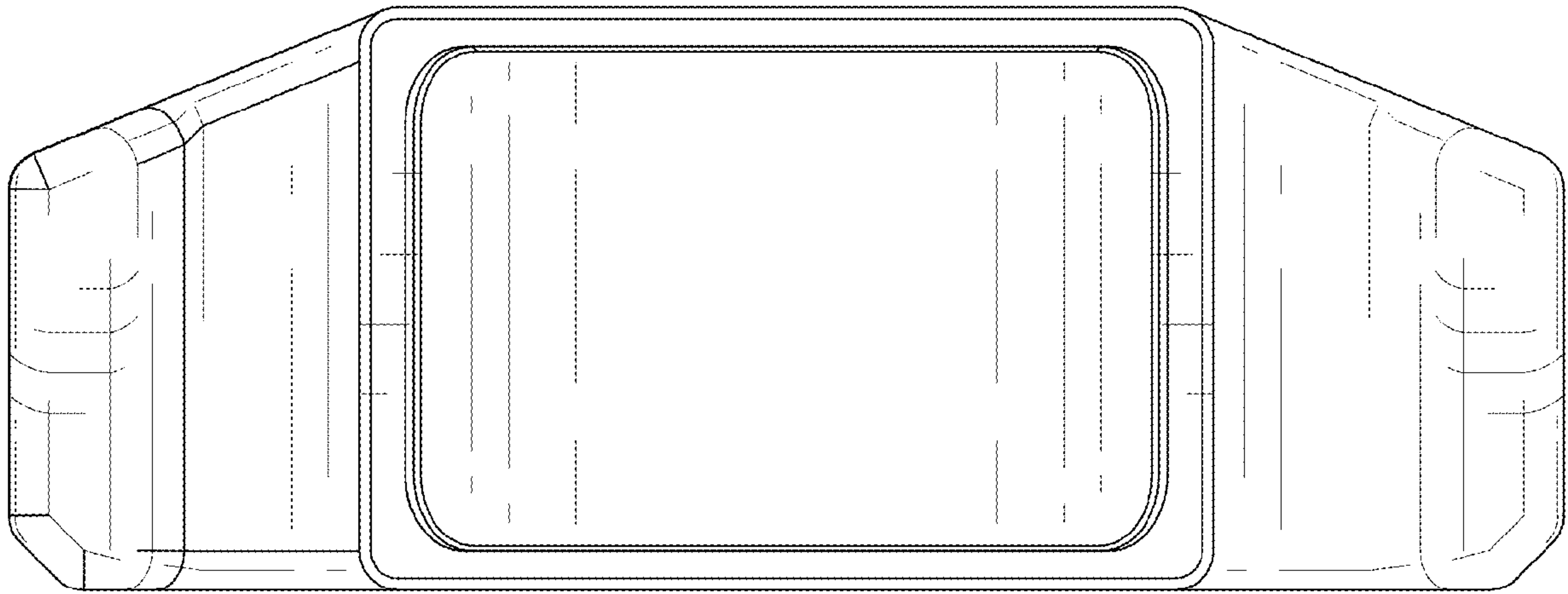

Fig-6

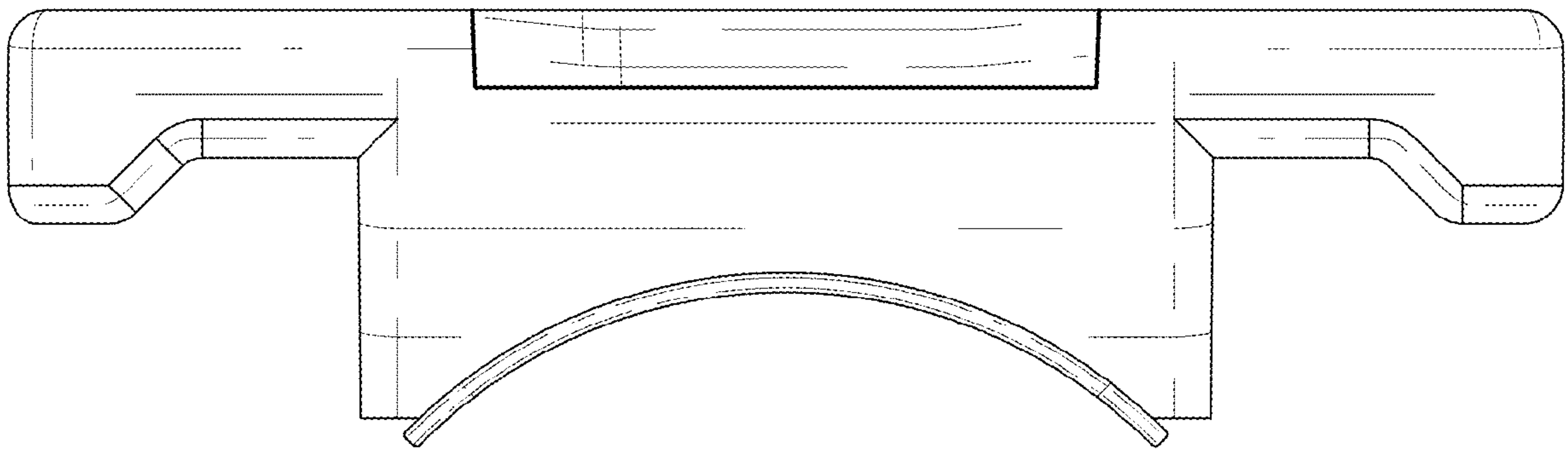

Fig-7

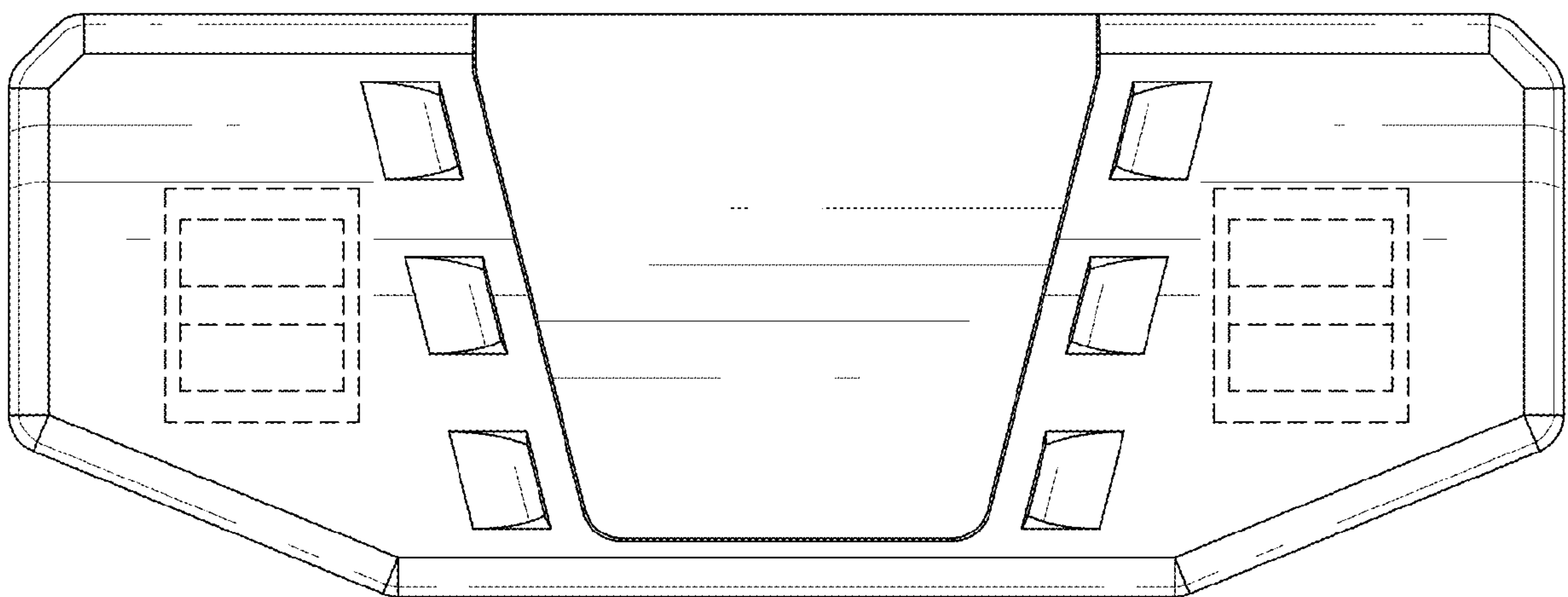

Fig-8