



US00D926824S

(12) **United States Design Patent** (10) **Patent No.:** **US D926,824 S**
Hemry et al. (45) **Date of Patent:** **** Aug. 3, 2021**

- (54) **BUMPER**
- (71) Applicant: **CATERPILLAR PAVING PRODUCTS INC.**, Brooklyn Park, MN (US)
- (72) Inventors: **Michael S. Hemry**, Maple Grove, MN (US); **Michael W. Ries**, Andover, MN (US); **Paco Romero**, Brooklyn Park, MN (US)
- (73) Assignee: **Caterpillar Paving Products Inc.**, Brooklyn Park, MN (US)
- (**) Term: **15 Years**
- (21) Appl. No.: **29/738,559**
- (22) Filed: **Jun. 18, 2020**

- D611,505 S 3/2010 Loew et al.
- D611,506 S 3/2010 Loew et al.
- D668,269 S 10/2012 Tezuka et al.
- D668,694 S 10/2012 Tezuka et al.
- D676,463 S 2/2013 Ewringmann et al.
- D694,278 S 11/2013 Ewringmann
- D694,279 S 11/2013 Ewringmann
- D699,764 S 2/2014 Loew et al.
- D720,779 S 1/2015 Loew et al.
- D728,629 S 5/2015 Loew
- D749,142 S 2/2016 Erdmann et al.
- D749,143 S 2/2016 Erdmann et al.
- D765,735 S 9/2016 Roemer et al.
- D789,424 S 6/2017 Roemer et al.
- D796,557 S 9/2017 Loew et al.
- D800,792 S 10/2017 Loew et al.
- D800,793 S 10/2017 Loew et al.
- D800,794 S 10/2017 Loew et al.
- D800,795 S 10/2017 Loew et al.
- D819,704 S 6/2018 Loew et al.

(Continued)

Primary Examiner — Mark A Goodwin

(74) *Attorney, Agent, or Firm* — Finnegan, Henderson, Farabow, Garrett & Dunner, LLP.

Related U.S. Application Data

- (63) Continuation of application No. 29/688,129, filed on Apr. 18, 2019, now Pat. No. Des. 896,283.
- (51) **LOC (13) Cl.** **15-03**
- (52) **U.S. Cl.**
USPC **D15/20**
- (58) **Field of Classification Search**
USPC D15/10, 20, 22–26, 28, 30, 33; 180/20, 180/89.12; 280/104, 124.11; 404/122, 404/132, 125, 90
CPC E02D 3/026; E02D 3/00; E02D 3/074; B30B 15/00; E01C 19/27; E01C 19/41; E01C 19/22; E01C 19/38; E01C 19/286; E01C 19/4853; E01C 19/238
See application file for complete search history.

(57) **CLAIM**

The ornamental design for a bumper, as shown and described.

DESCRIPTION

FIG. 1 is a front, top, left perspective view of a bumper of showing the new design;
 FIG. 2 is rear, bottom, left perspective view thereof;
 FIG. 3 is front elevation view thereof;
 FIG. 4 is rear elevation view thereof;
 FIG. 5 is left side view thereof;
 FIG. 6 is right side view thereof;
 FIG. 7 is top plan view thereof; and,
 FIG. 8 is bottom plan view thereof.
 The broken lines of even length shown in the drawings illustrate portions of the bumper that form no part of the claimed design.

(56) **References Cited**

U.S. PATENT DOCUMENTS

- D396,431 S 7/1998 Lindgren et al.
- D516,094 S 2/2006 Dötsch et al.

1 Claim, 8 Drawing Sheets

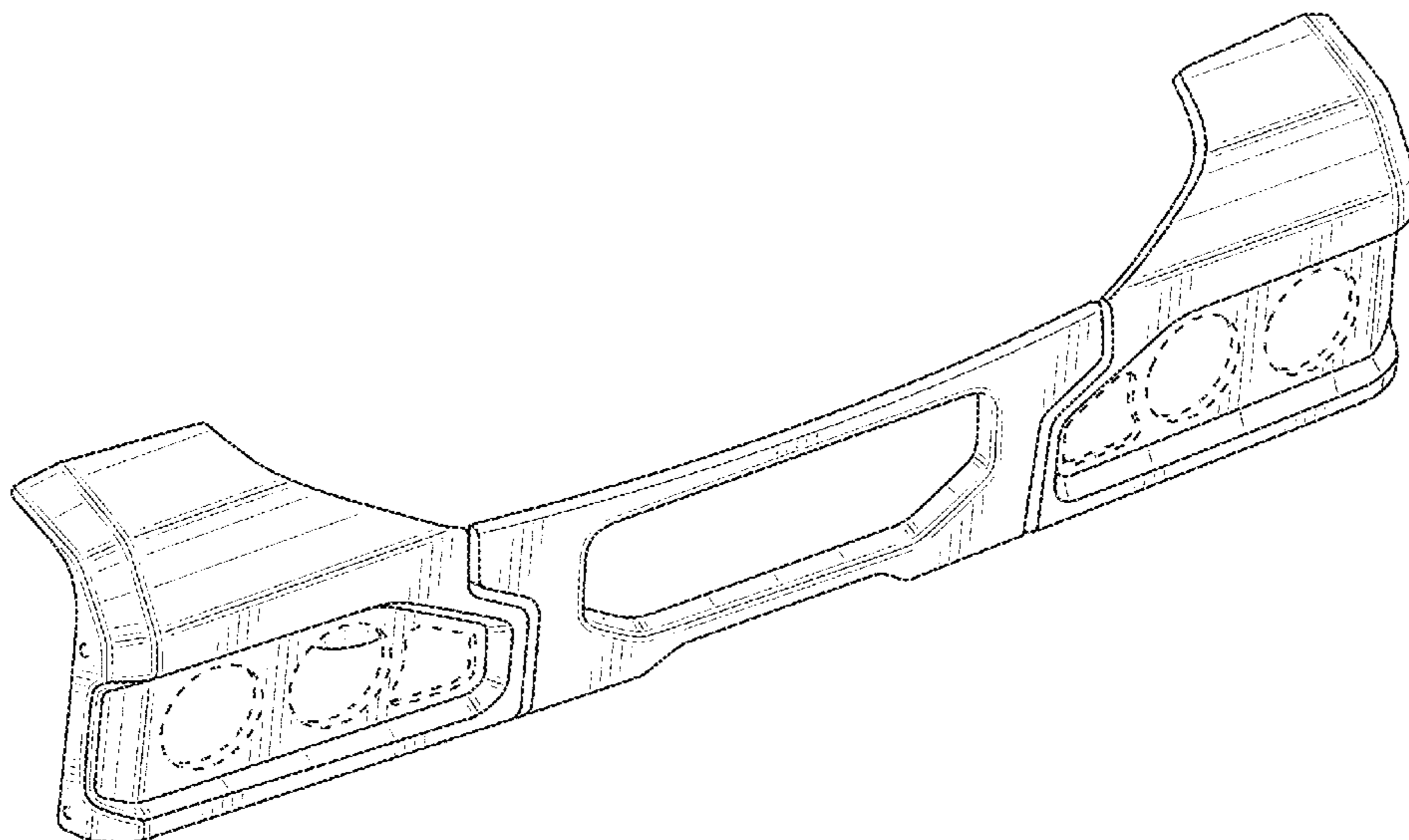

(56)

References Cited

U.S. PATENT DOCUMENTS

D853,450 S 7/2019 Loew
D853,451 S 7/2019 Loew

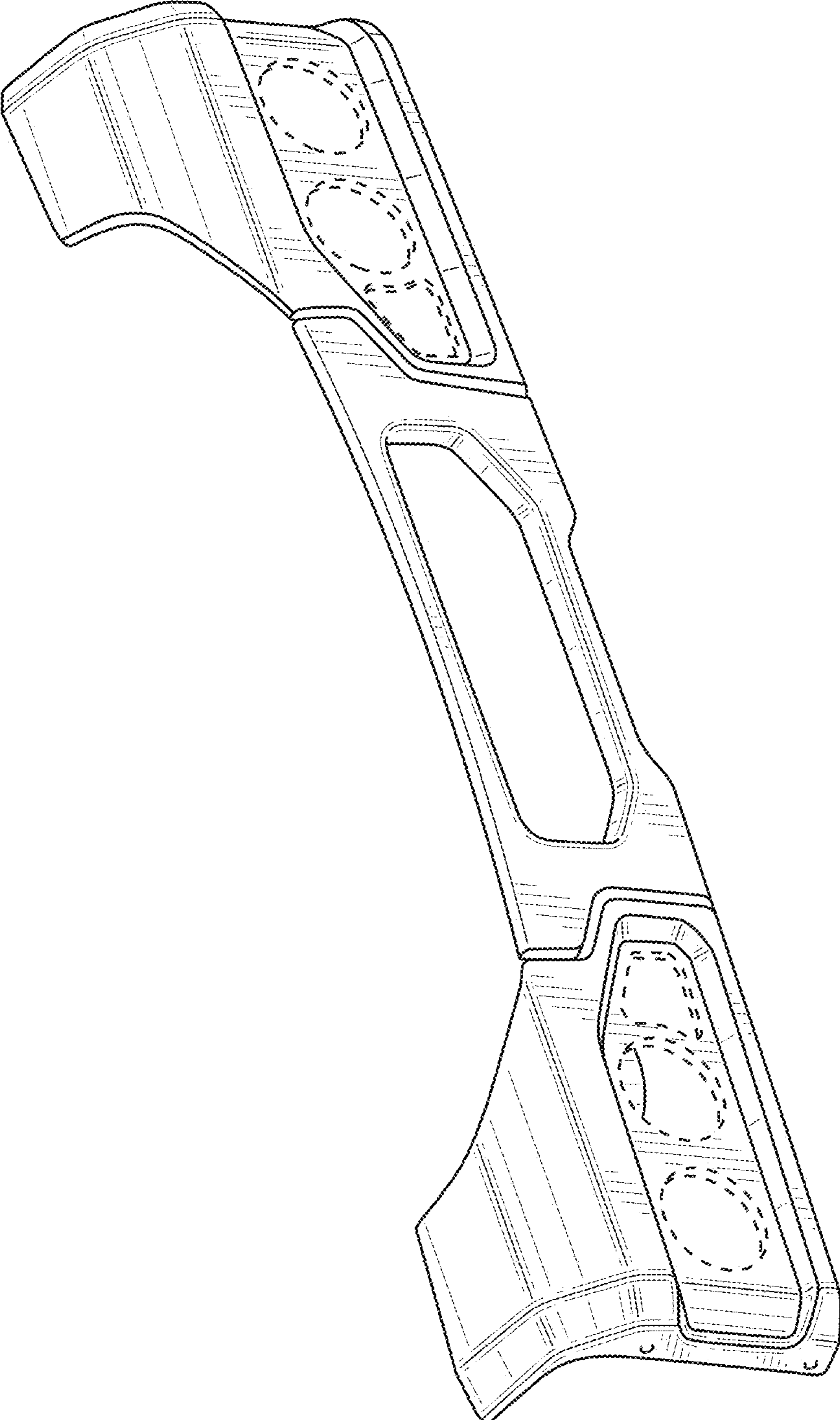

FIG. 1

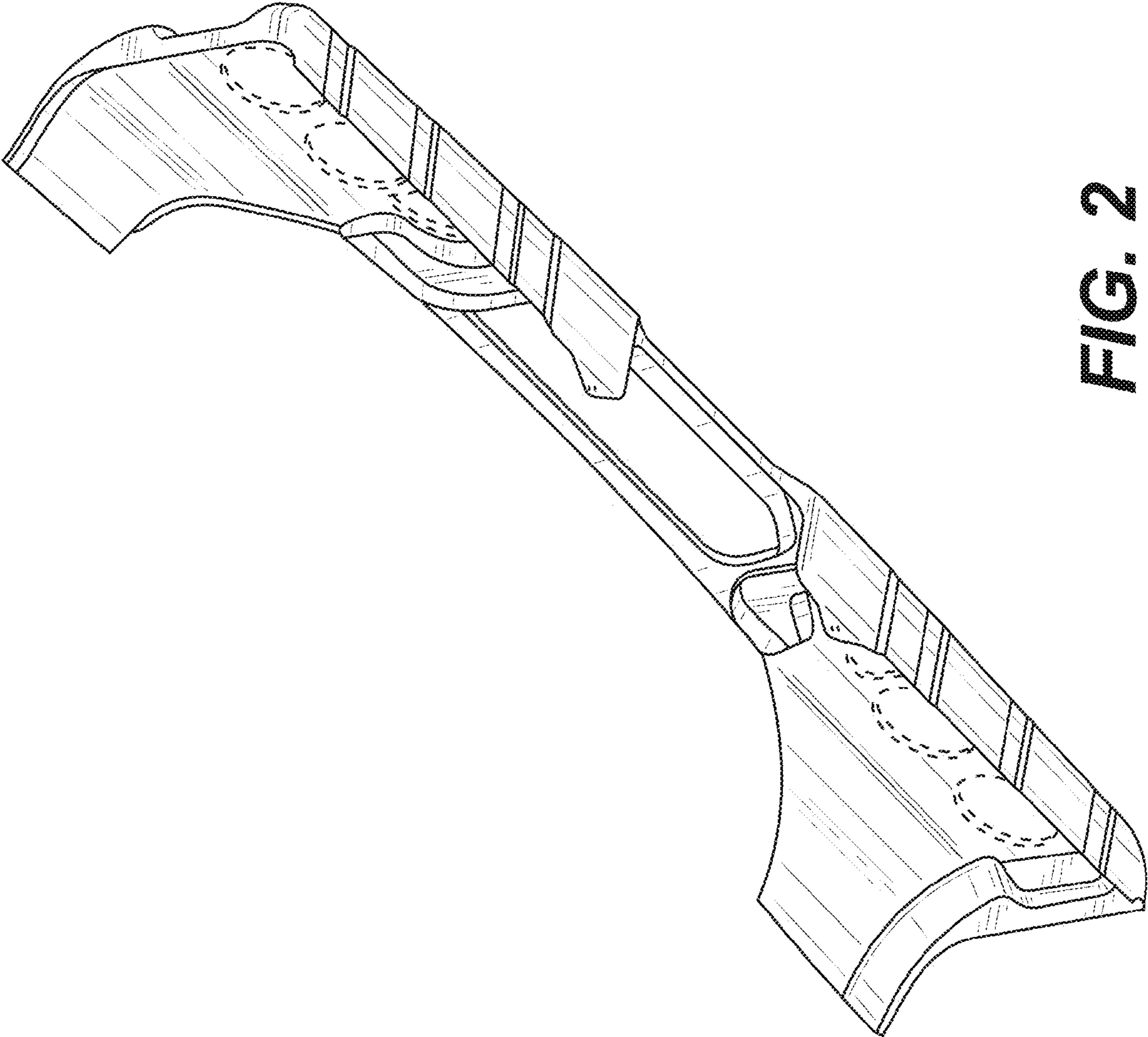

FIG. 2

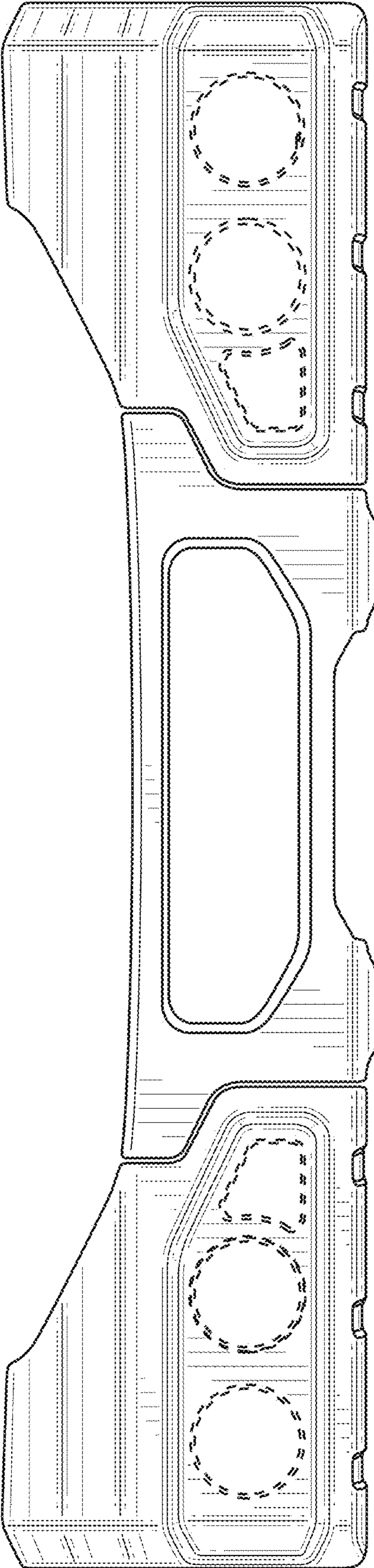

FIG. 3

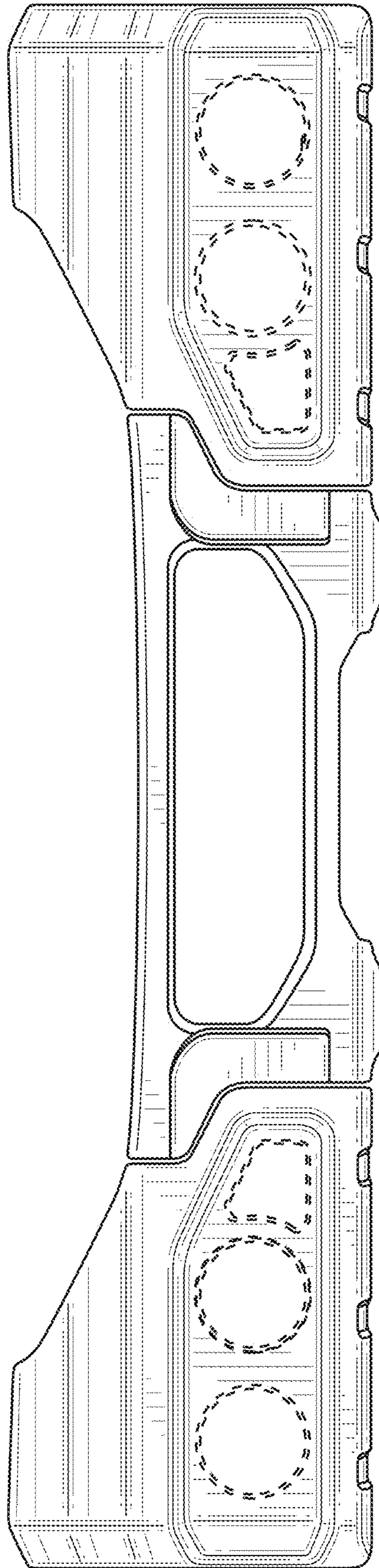

FIG. 4

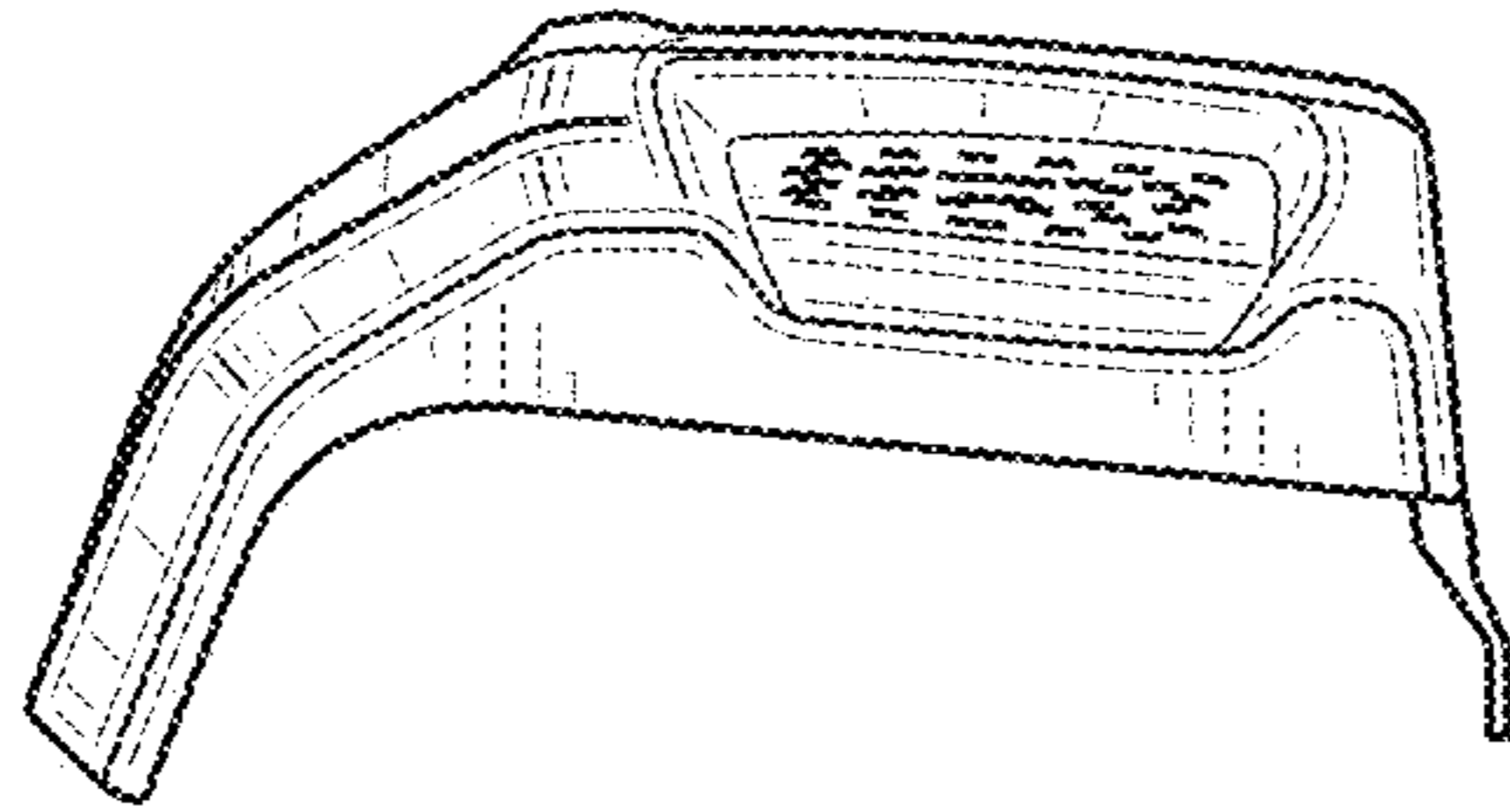

FIG. 5

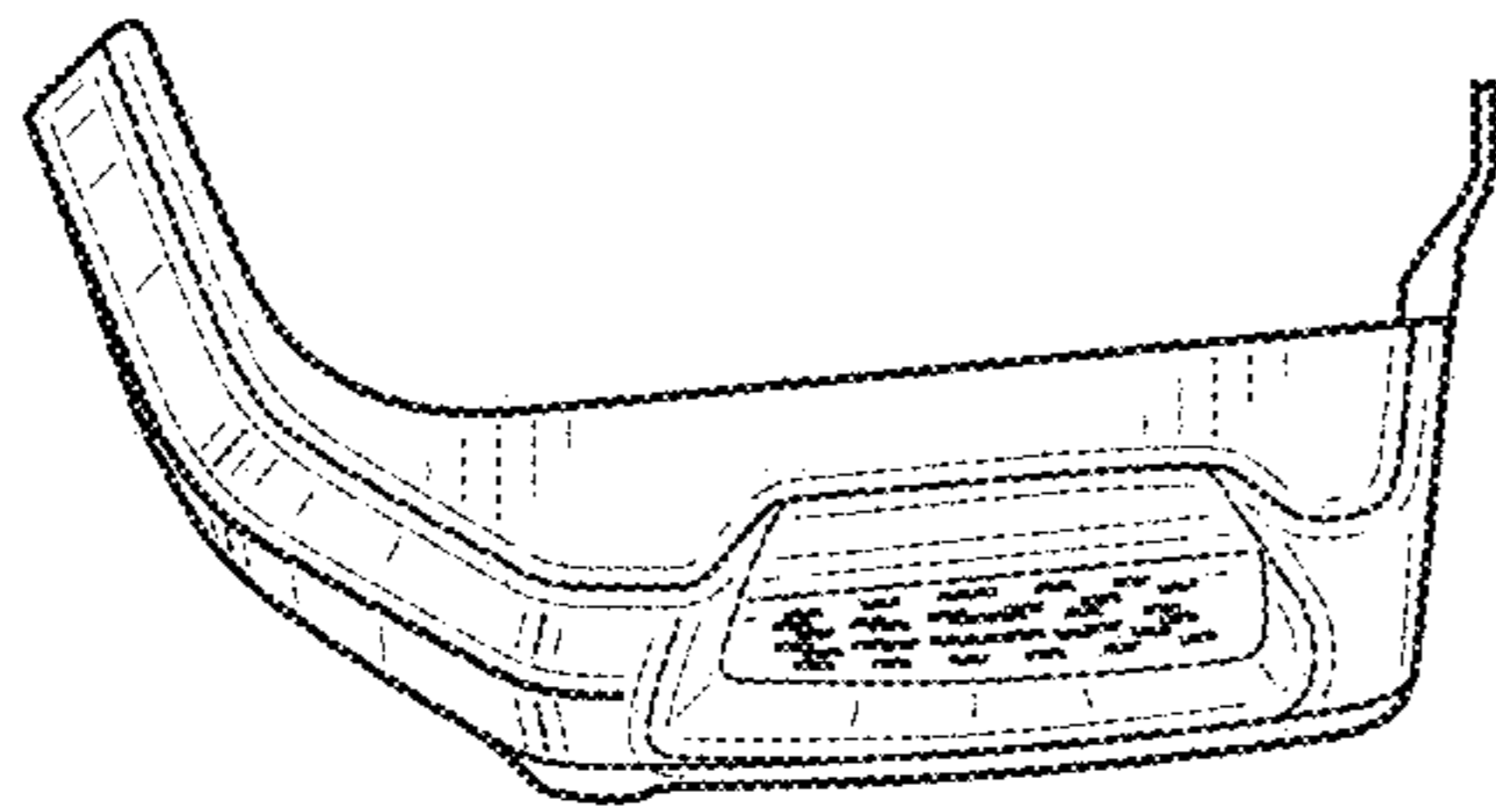

FIG. 6



FIG. 7

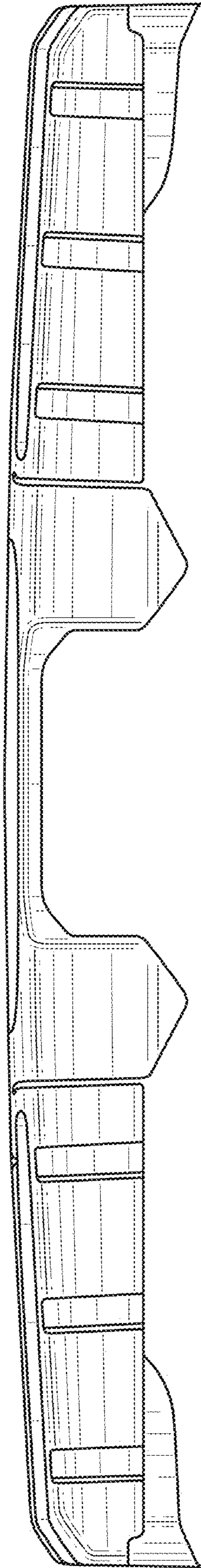

FIG. 8