



US00D926633S

(12) **United States Design Patent**
Coyne et al.

(10) **Patent No.:** **US D926,633 S**

(45) **Date of Patent:** **** Aug. 3, 2021**

(54) **RAIL CLEANER**

(71) Applicant: **Transportation IP Holdings, LLC,**
Norwalk, CT (US)

(72) Inventors: **Jennifer Lynn Coyne**, Erie, PA (US);
Adrian Jerzy Gorski, Erie, PA (US);
Justin Winston, Lawrence Park, PA
(US); **Jeremy Thomas McGarry**,
Lawrence Park, PA (US); **Priyanka**
Chandrakant Ghate, Bangalore (IN);
Naren Dhass Srinivasamoorthy,
Bangalore (IN); **Xiaobo Xie**, Shanghai
(CN); **Jingjun Zhang**, Erie, PA (US)

(73) Assignee: **TRANSPORTATION IP HOLDINGS,**
LLC, Norwalk, CT (US)

(**) Term: **15 Years**

(21) Appl. No.: **29/601,691**

(22) Filed: **Apr. 25, 2017**

(51) **LOC (13) Cl.** **12-03**

(52) **U.S. Cl.**
USPC **D12/50**

(58) **Field of Classification Search**
USPC D12/36-51; D32/40, 46, 49, 52
CPC .. E01H 8/12; E01H 8/105; E01H 8/10; E01H
8/125
See application file for complete search history.

(56) **References Cited**

U.S. PATENT DOCUMENTS

689,024 A * 12/1901 Rom E01H 8/12
37/205
1,570,191 A * 1/1926 Wyrembek E01H 8/12
37/207

2,719,312 A * 10/1955 Hyland E01H 8/12
15/55
3,641,618 A * 2/1972 Rainey E01H 8/105
15/312.1
D841,517 S * 2/2019 LaCroix D12/49

FOREIGN PATENT DOCUMENTS

DE 387766 C * 1/1924 E01H 8/12
FR 322771 A * 2/1903 E01H 8/12
FR 583680 A * 1/1925 E01H 8/12

* cited by examiner

Primary Examiner — Ania Aman

(74) *Attorney, Agent, or Firm* — McCoy Russell LLP

(57) **CLAIM**

The ornamental design for a rail cleaner, as shown and described.

DESCRIPTION

FIG. 1 is a perspective view of a rail cleaner depicting a new design;
FIG. 2 is another perspective view thereof;
FIG. 3 is a front view thereof;
FIG. 4 is a rear view thereof;
FIG. 5 is a side view thereof;
FIG. 6 is an opposite side view thereof;
FIG. 7 is a top view thereof; and,
FIG. 8 is a bottom view thereof.

The broken line portion of the figure drawings is included to show unclaimed subject matter only and forms no part of the claimed design. Moreover, the rail section shown in broken lines is intended to provide environmental context and forms no part of the claimed design.

1 Claim, 5 Drawing Sheets

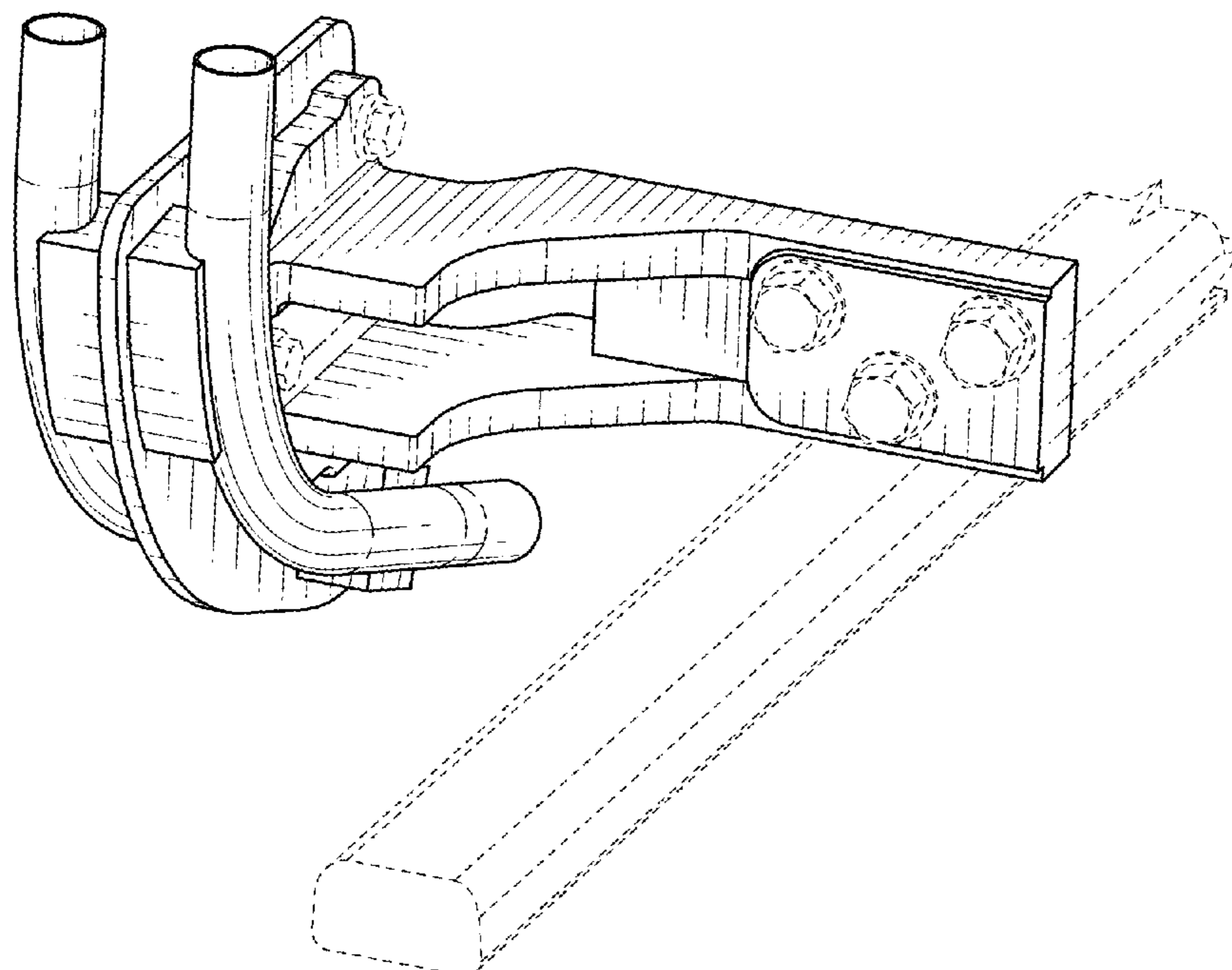

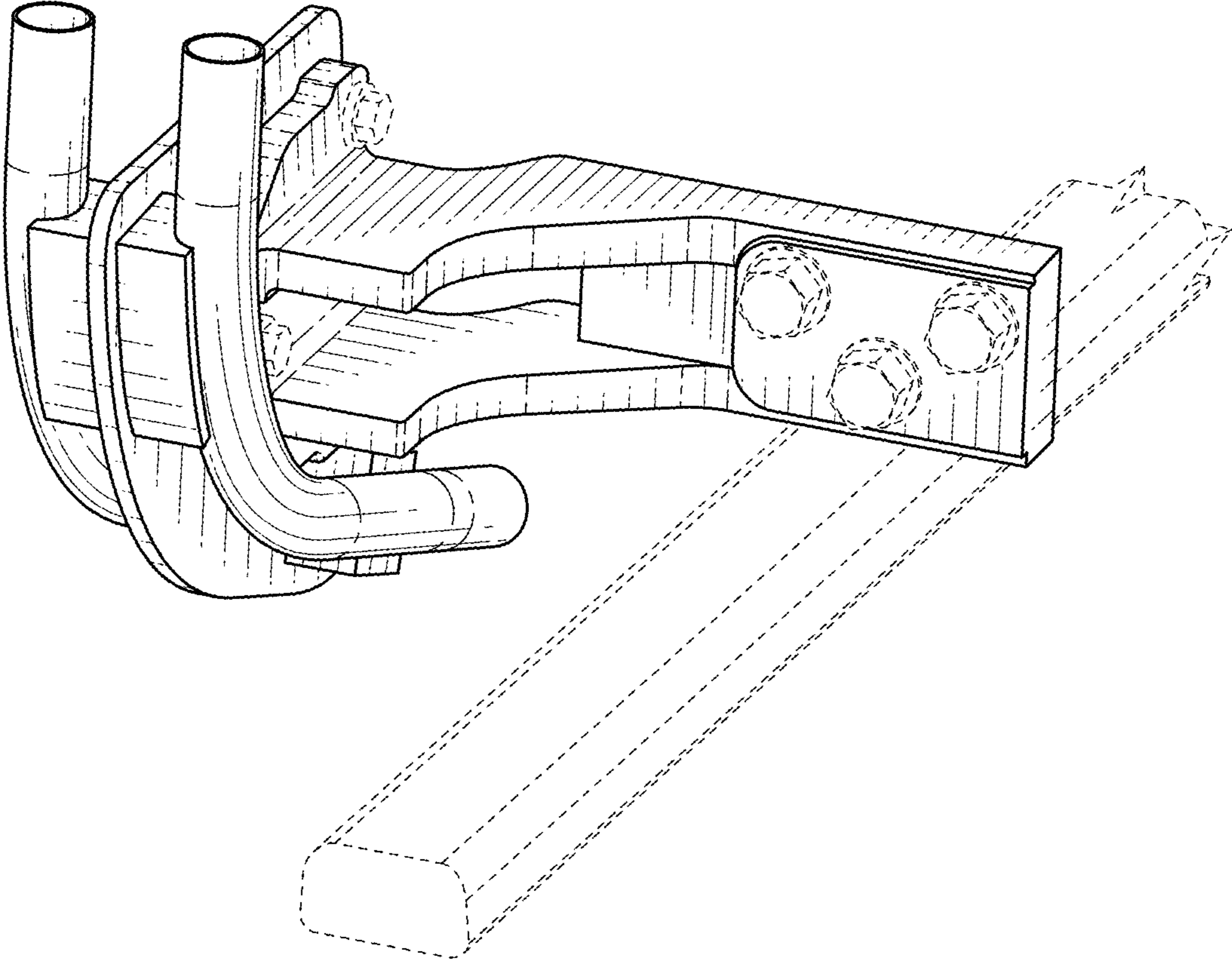

FIG. 1

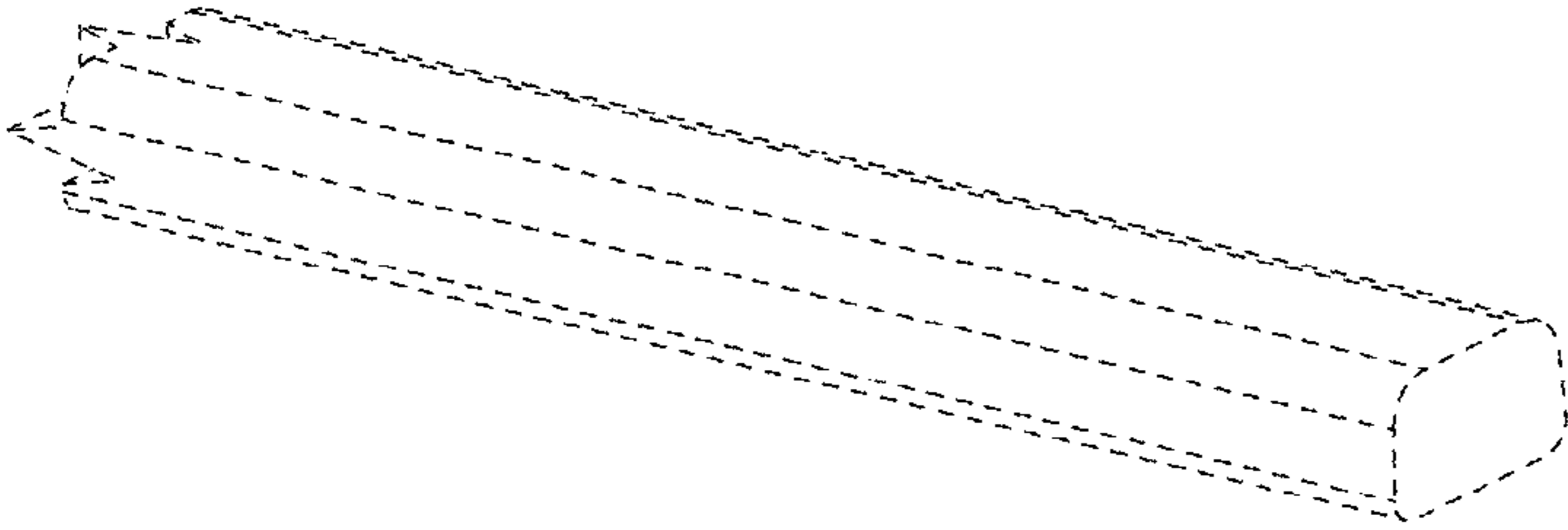
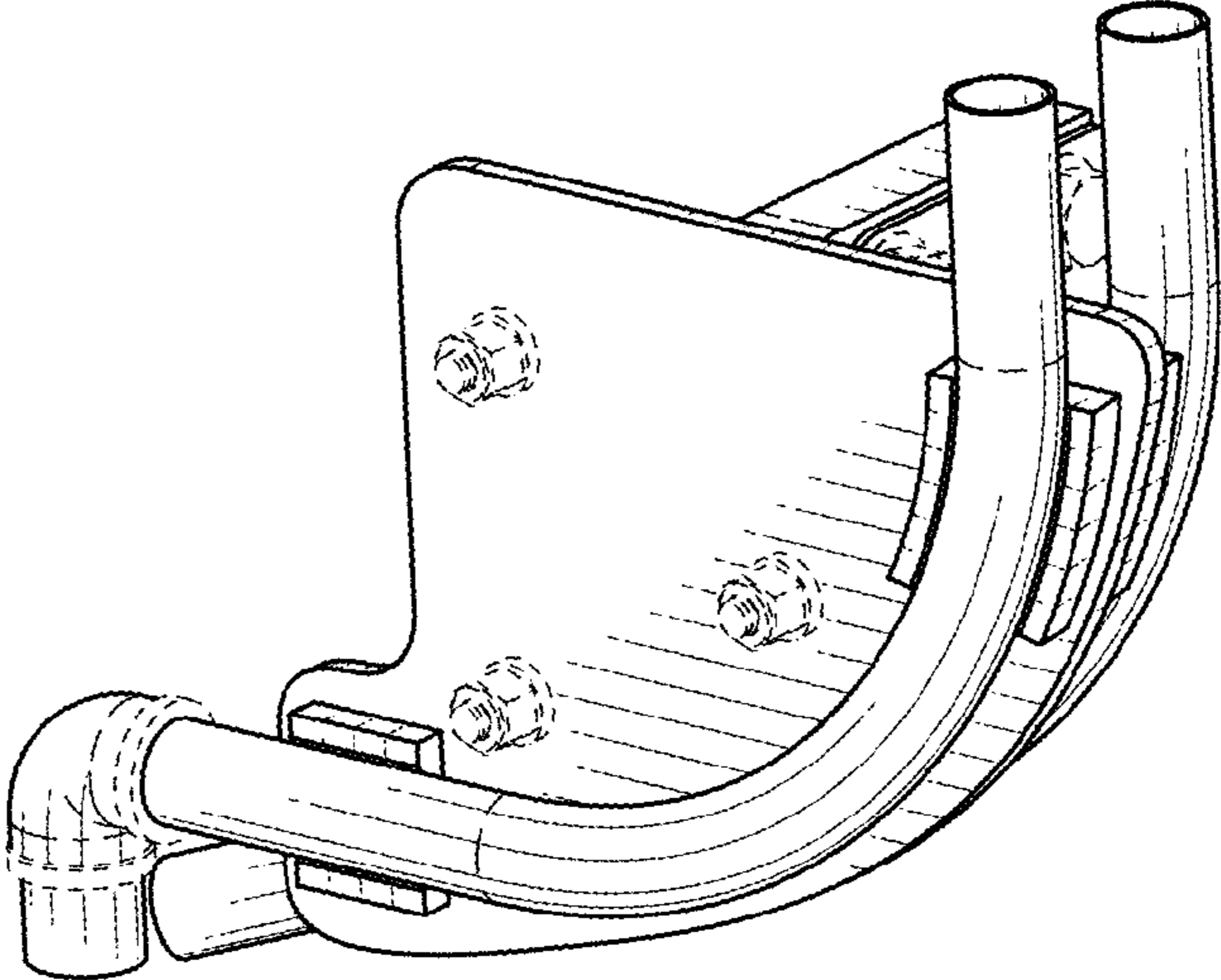

FIG. 2

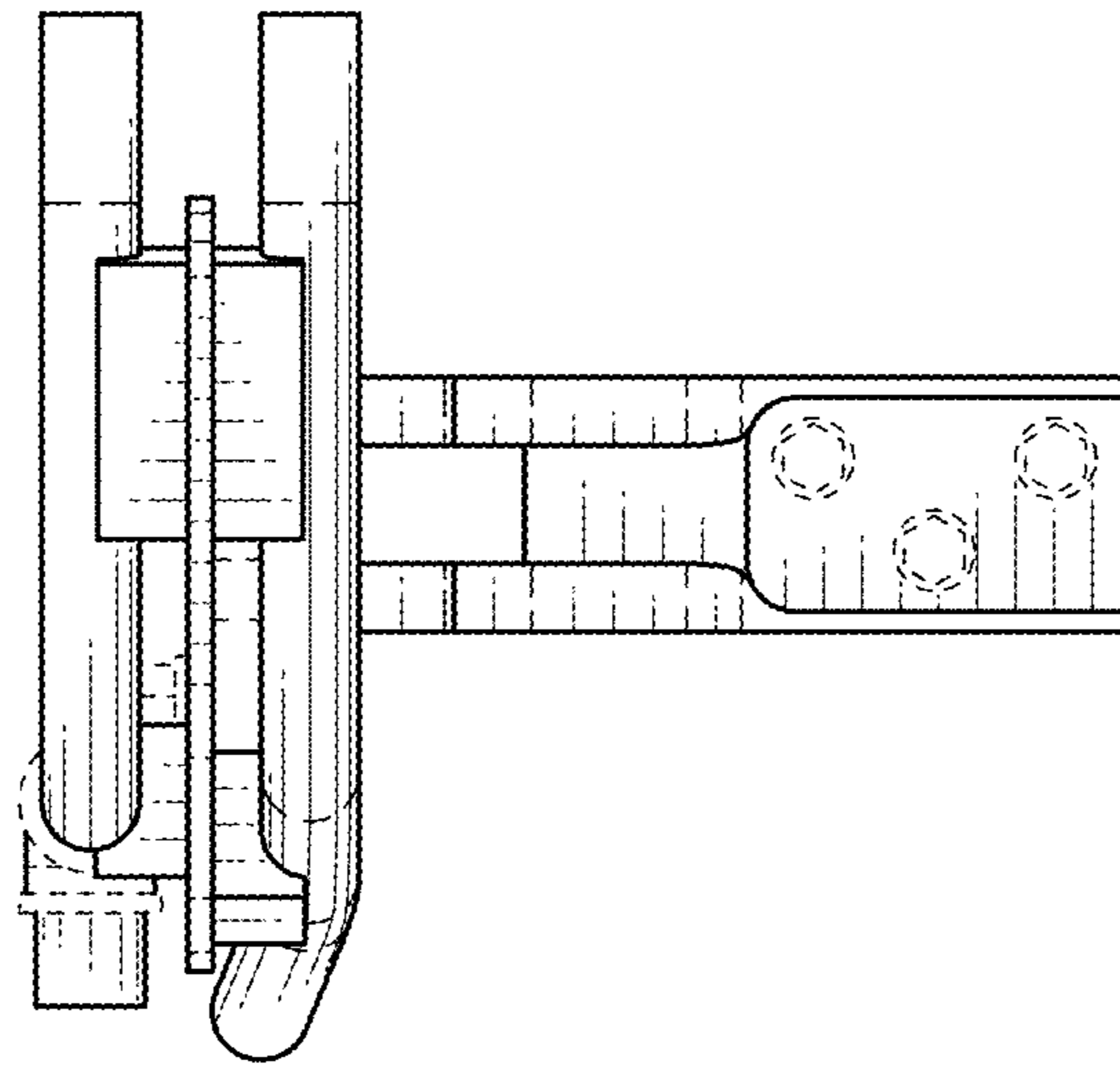

FIG. 3

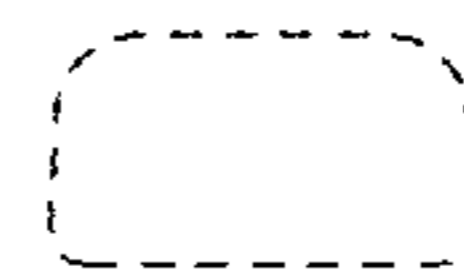
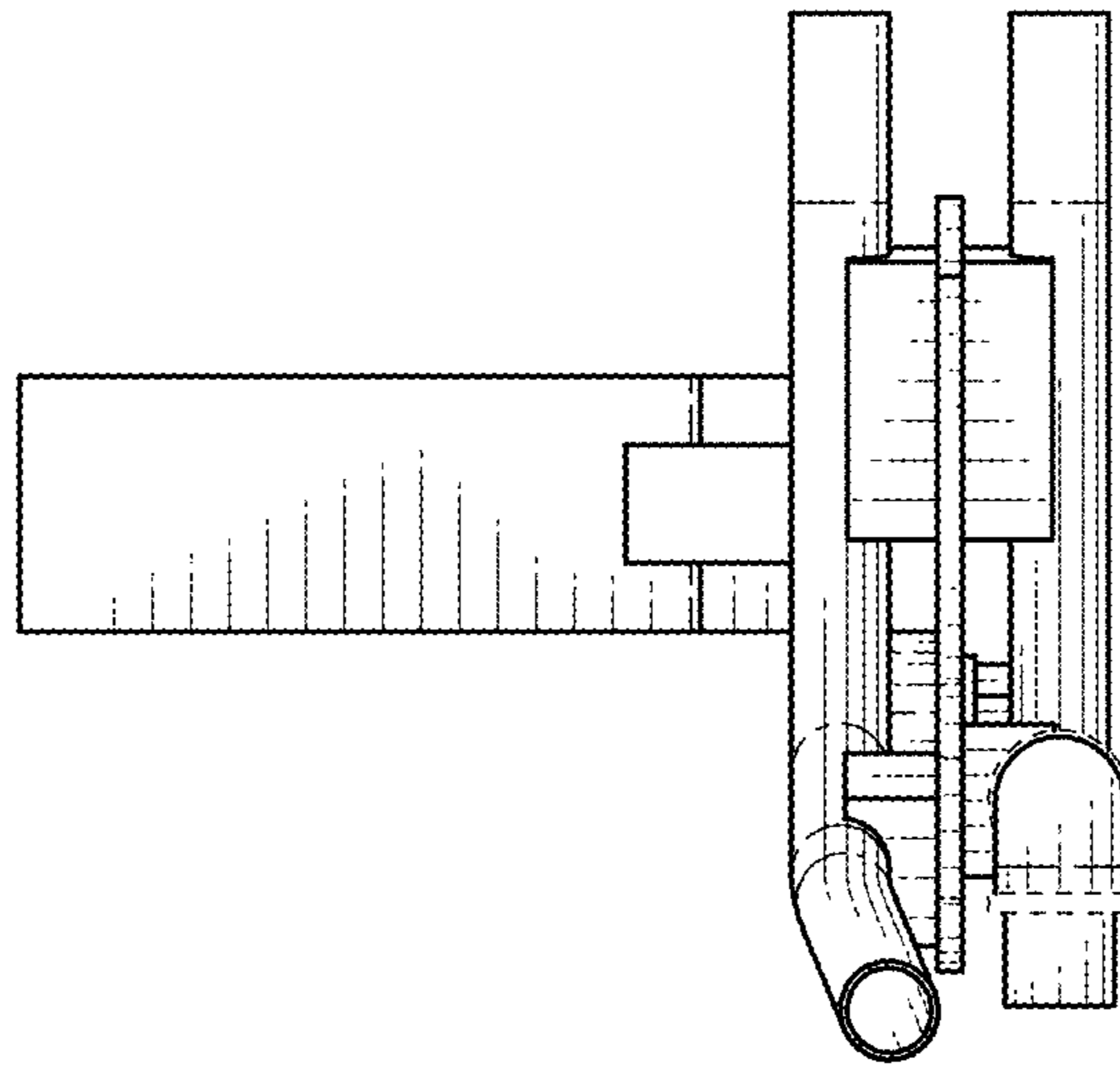

FIG. 4

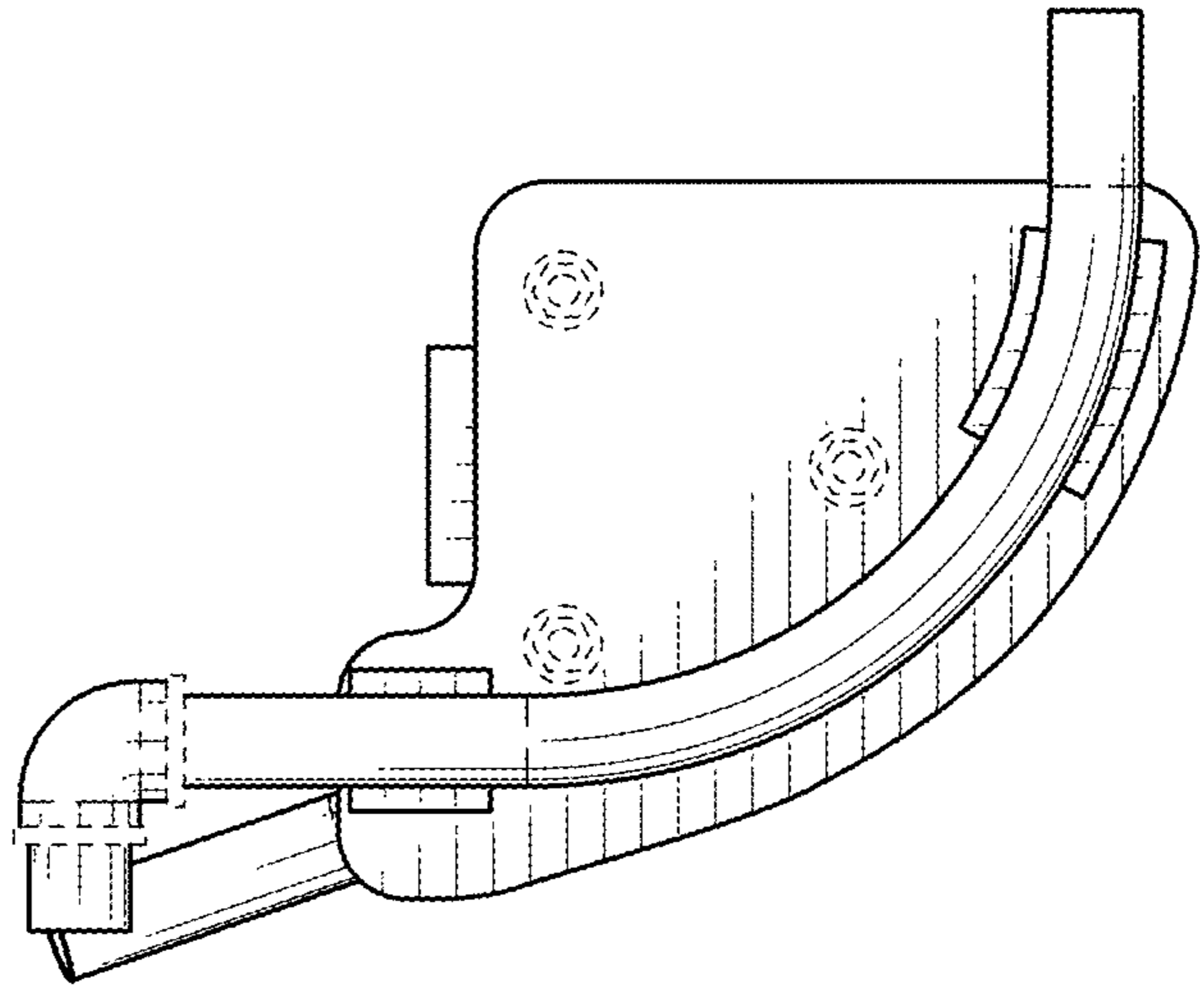

FIG. 5

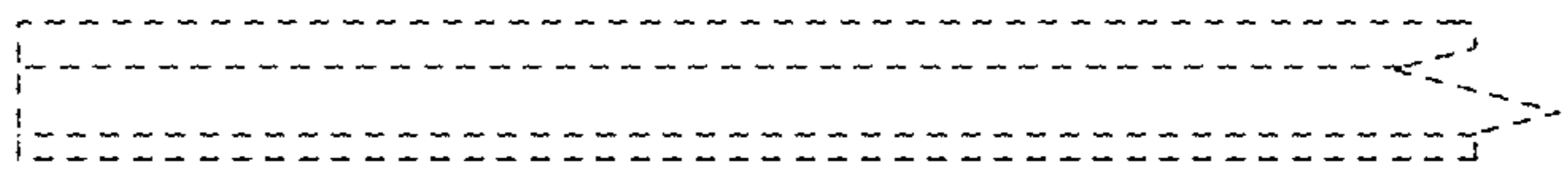
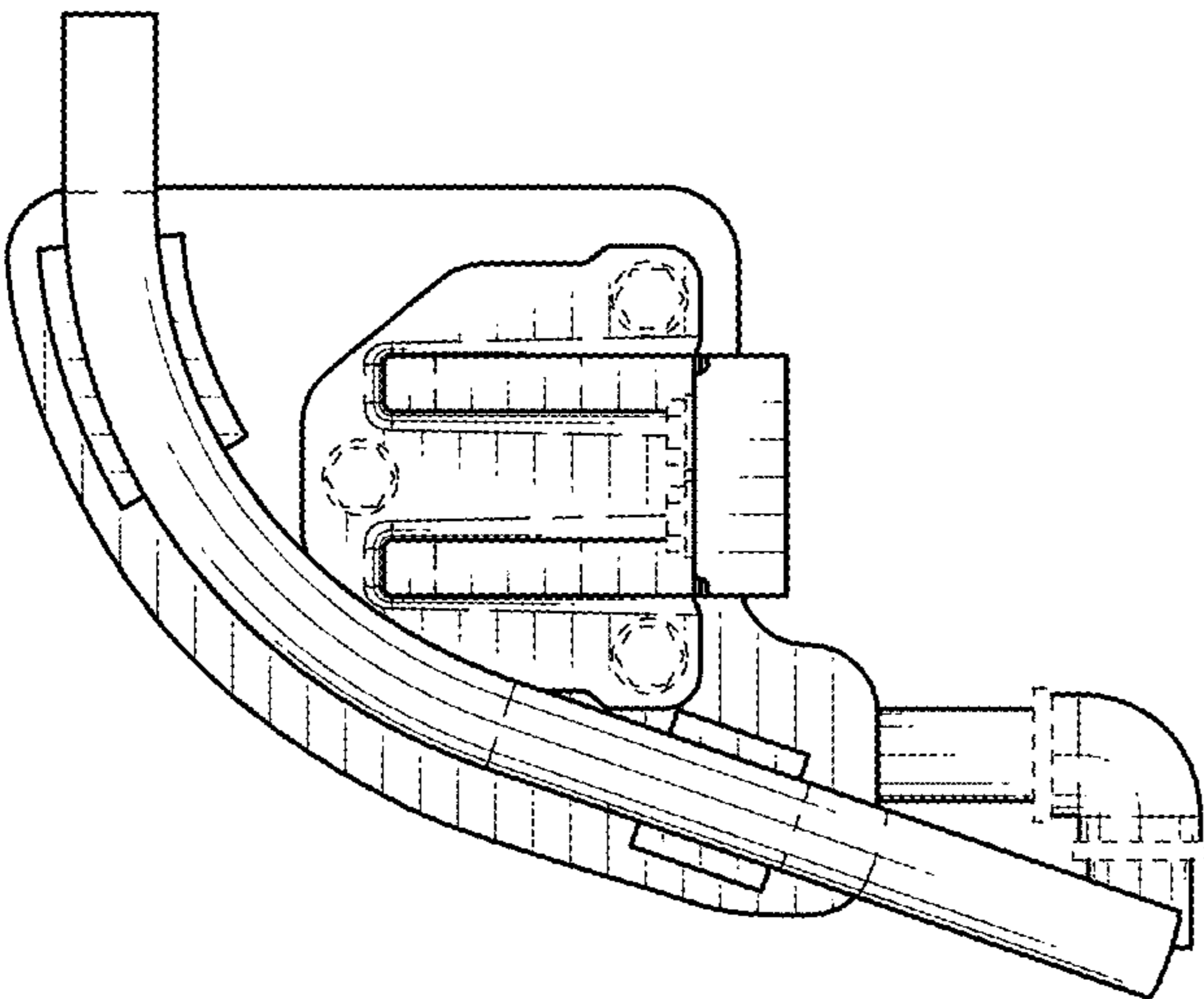

FIG. 6

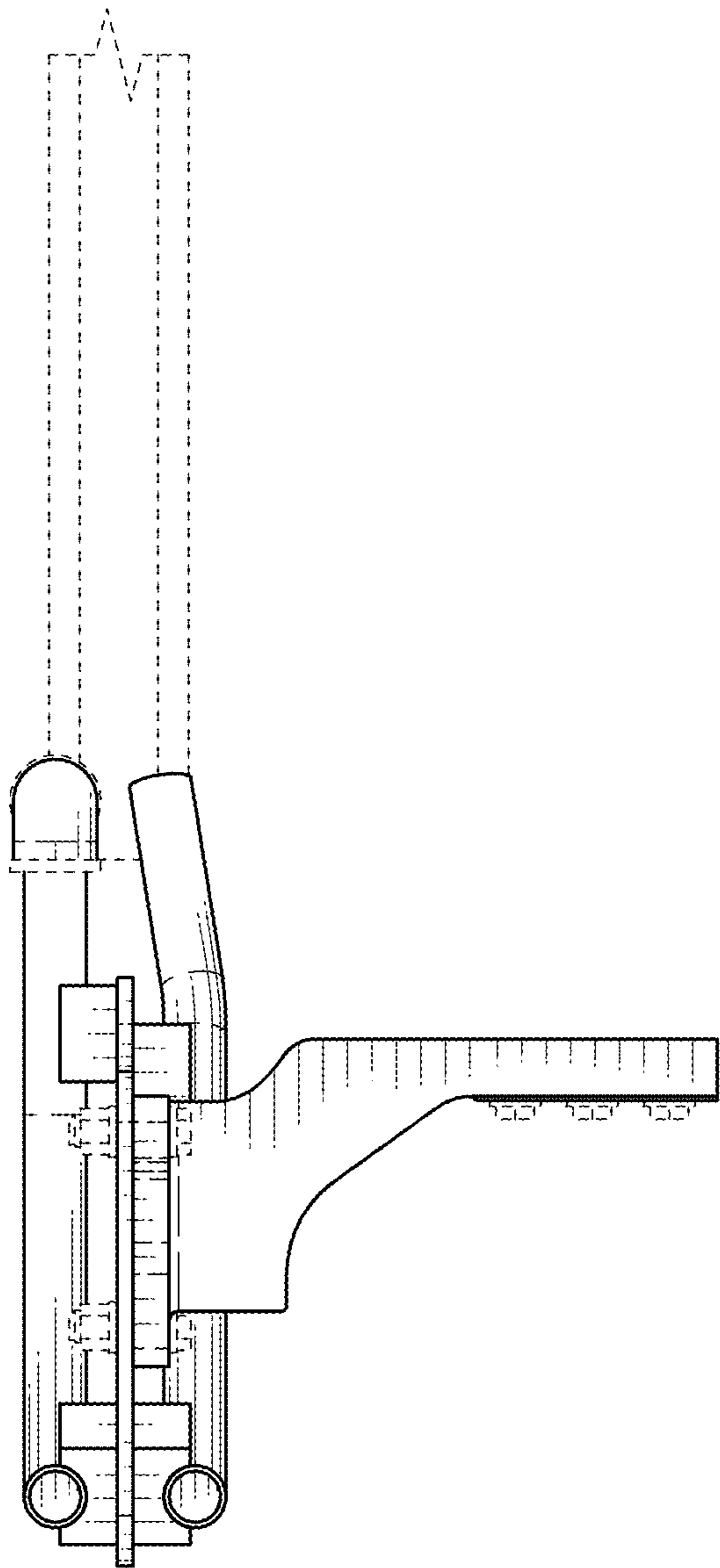

FIG. 7

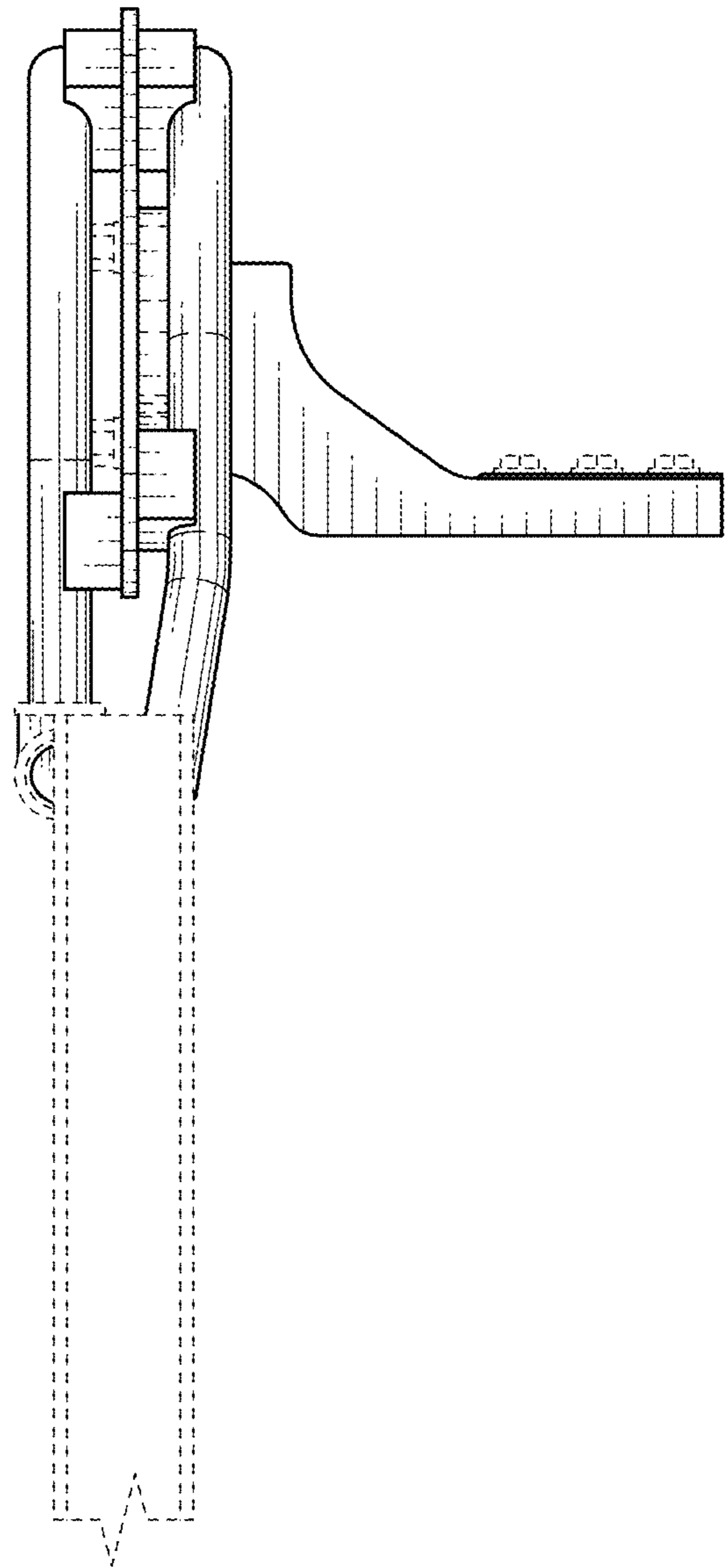

FIG. 8