



US00D926586S

(12) **United States Design Patent** (10) **Patent No.:** **US D926,586 S**
Örtegren (45) **Date of Patent:** **** Aug. 3, 2021**

- (54) **PERFUME BOTTLE**
- (71) Applicant: **H & M Hennes & Mauritz AB**,
Stockholm (SE)
- (72) Inventor: **Jesper Sundberg Örtegren**, Stockholm
(SE)
- (73) Assignee: **H&M Hennes & Mauritz AB**,
Stockholm (SE)
- (**) Term: **15 Years**
- (21) Appl. No.: **29/650,456**
- (22) Filed: **Jun. 6, 2018**
- (51) **LOC (13) Cl.** **09-01**
- (52) **U.S. Cl.**
USPC **D9/691; D9/503**
- (58) **Field of Classification Search**
USPC D9/500–505, 682, 688–692, 516, 517,
D9/519, 521, 537–540, 545, 549–558,
D9/434–436, 439, 440, 445, 448;
D28/76, 77, 91, 91.1
CPC B05B 11/00–3098; B65D 83/14; B65D
83/16; B65D 83/20; B65D 83/201; B65D
83/205; B65D 83/206; B65D 83/207;
B65D 83/38; B65D 83/382; B65D
83/384; B65D 83/386; B65D 83/40;
B65D 83/42; B65D 83/75; B65D 83/752;
A45D 34/02; A45D 34/04; A45D 34/06;
A45D 2034/002; A45D 2034/005; A45D
2034/007; A45D 2200/054–058
See application file for complete search history.

(56) **References Cited**
U.S. PATENT DOCUMENTS

D36,493 S *	8/1903	Alland	D9/505
D84,683 S *	7/1931	Davis	D9/503
D166,595 S *	4/1952	Du Pree	D7/300

D239,159 S *	3/1976	Picker	D9/503
D256,992 S *	9/1980	Kretz	D9/558
D259,332 S *	5/1981	Walton	D9/545
D266,650 S *	10/1982	Sarpaneva	D7/317
D337,055 S *	7/1993	Medlycott	D9/545
D364,669 S *	11/1995	Winner	D22/117
D366,422 S *	1/1996	Gobe	D9/544
D368,860 S *	4/1996	Mansau	D9/545
D375,675 S *	11/1996	Luzzi	D9/503
D421,390 S *	3/2000	DuGrenier	D9/684
D423,924 S *	5/2000	Laracy	D11/157
D427,516 S *	7/2000	Legros	D9/546
D449,516 S *	10/2001	Modjeski	D9/503
6,371,334 B1 *	4/2002	Lombardi	A45D 34/02 222/325
D474,406 S *	5/2003	Kaposi	D7/598
D485,762 S *	1/2004	Ungrady	D9/503
D497,795 S *	11/2004	Fling	D9/692

(Continued)

FOREIGN PATENT DOCUMENTS

CN	3376840	*	7/2004
CN	3487138	*	11/2005

(Continued)

Primary Examiner — Catherine A Tuttle
(74) *Attorney, Agent, or Firm* — Peroff Saunders P.C.

(57) **CLAIM**

The ornamental design for a perfume bottle, as shown and described.

DESCRIPTION

FIG. 1 is a top perspective view showing my new design for a perfume bottle;
FIG. 2 is a front view thereof;
FIG. 3 is a top plan view thereof;
FIG. 4 is a bottom plan view thereof; and,
FIG. 5 is an exploded front view thereof.
The circular broken line and bottom end region defined thereby form no part of the claimed design.

1 Claim, 4 Drawing Sheets

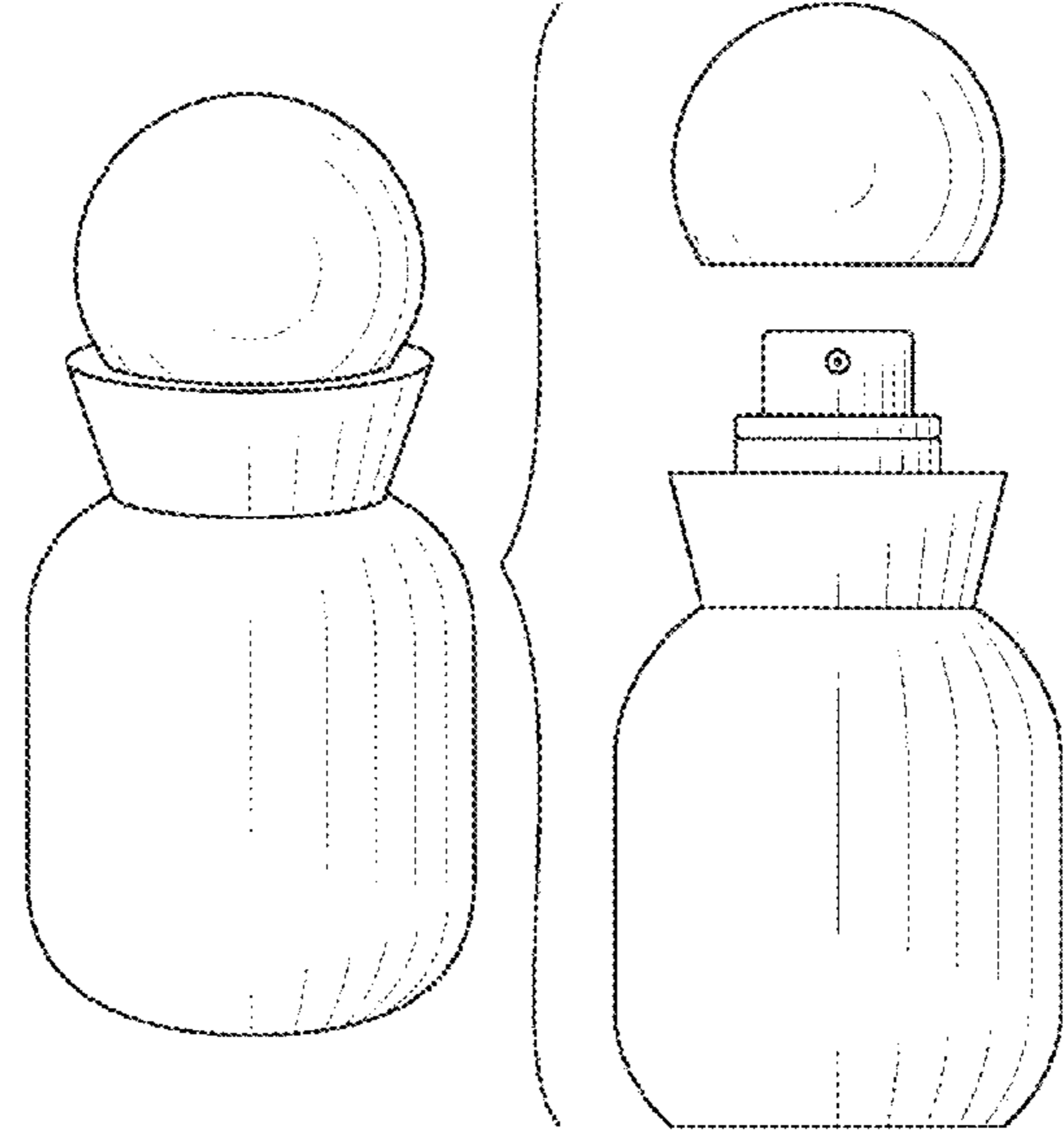

(56)

References Cited

U.S. PATENT DOCUMENTS

D576,880 S * 9/2008 Couey D9/503
D596,950 S * 7/2009 Nevins D9/503
D694,121 S * 11/2013 Park D9/682
D715,157 S * 10/2014 In D9/691
D795,699 S * 8/2017 Vivas D9/545
D906,115 S * 12/2020 Louis D9/503

FOREIGN PATENT DOCUMENTS

CN 300747065 * 2/2008
CN 301383983 * 11/2010
CN 302401312 * 4/2013
CN 302412072 * 4/2013
CN 302412073 * 4/2013
CN 302421345 * 5/2013
CN 303166905 * 4/2015
CN 303463745 * 11/2015
CN 303539408 * 1/2016
CN 304239362 * 8/2017

* cited by examiner

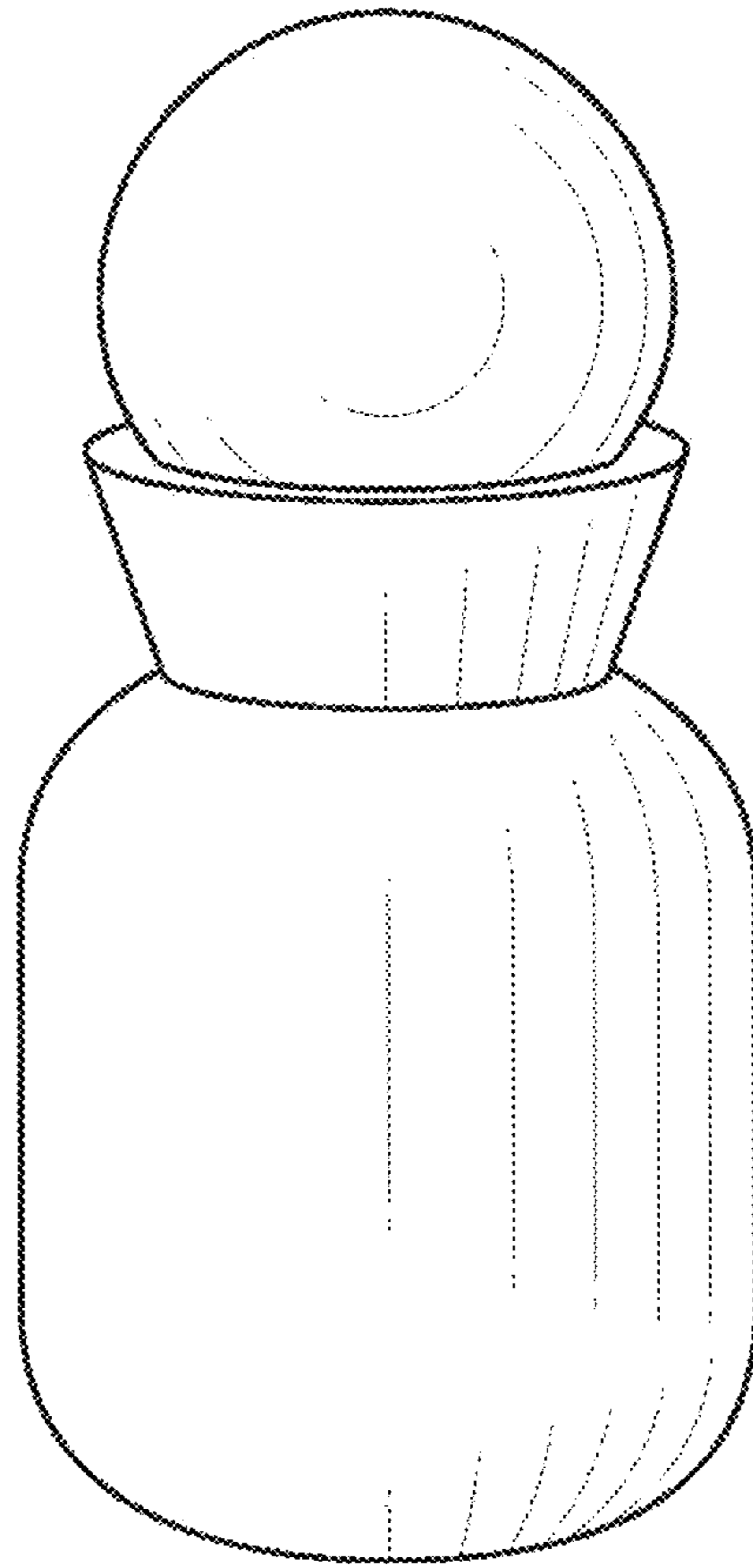

FIG. 1

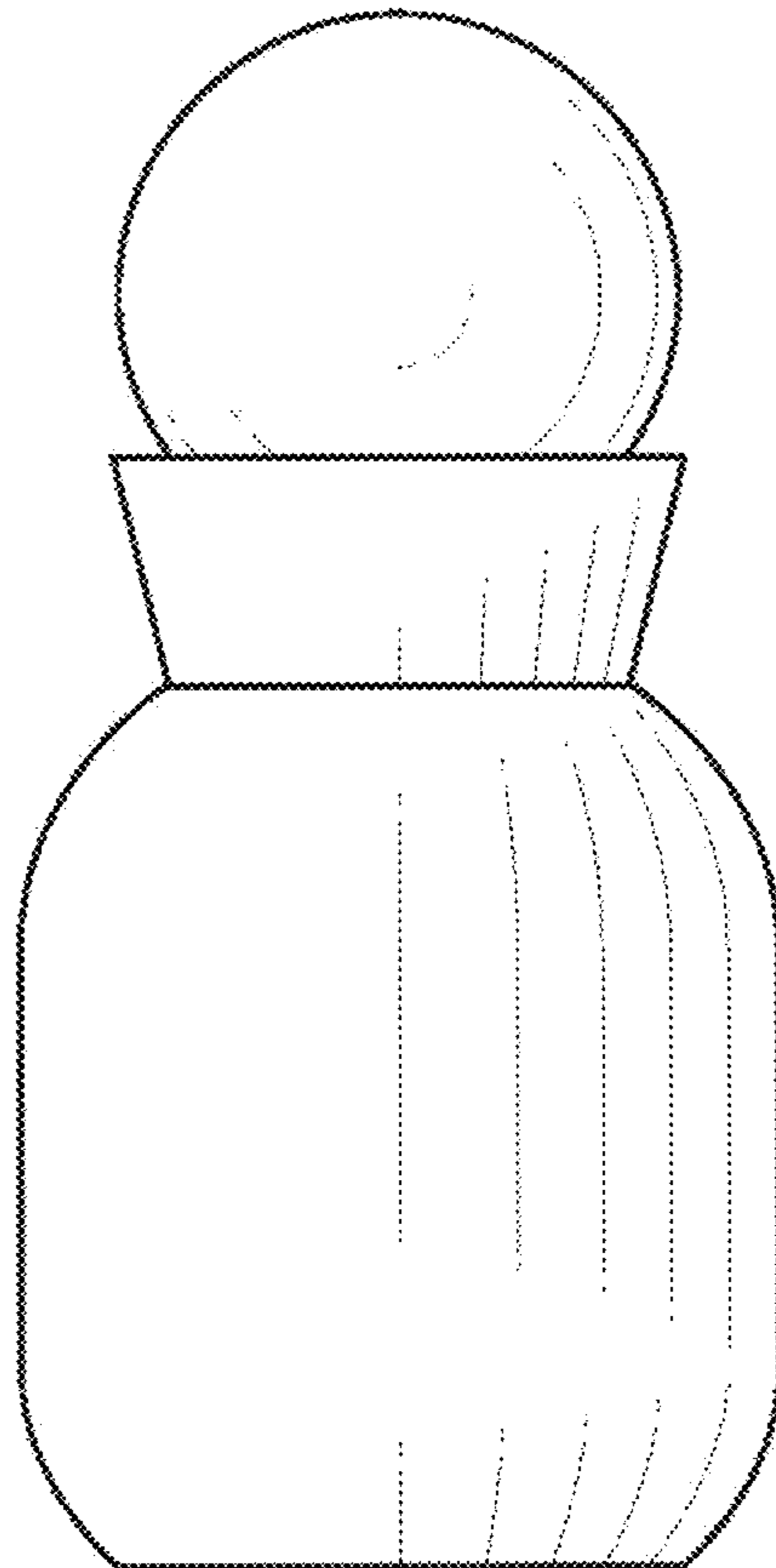

FIG. 2

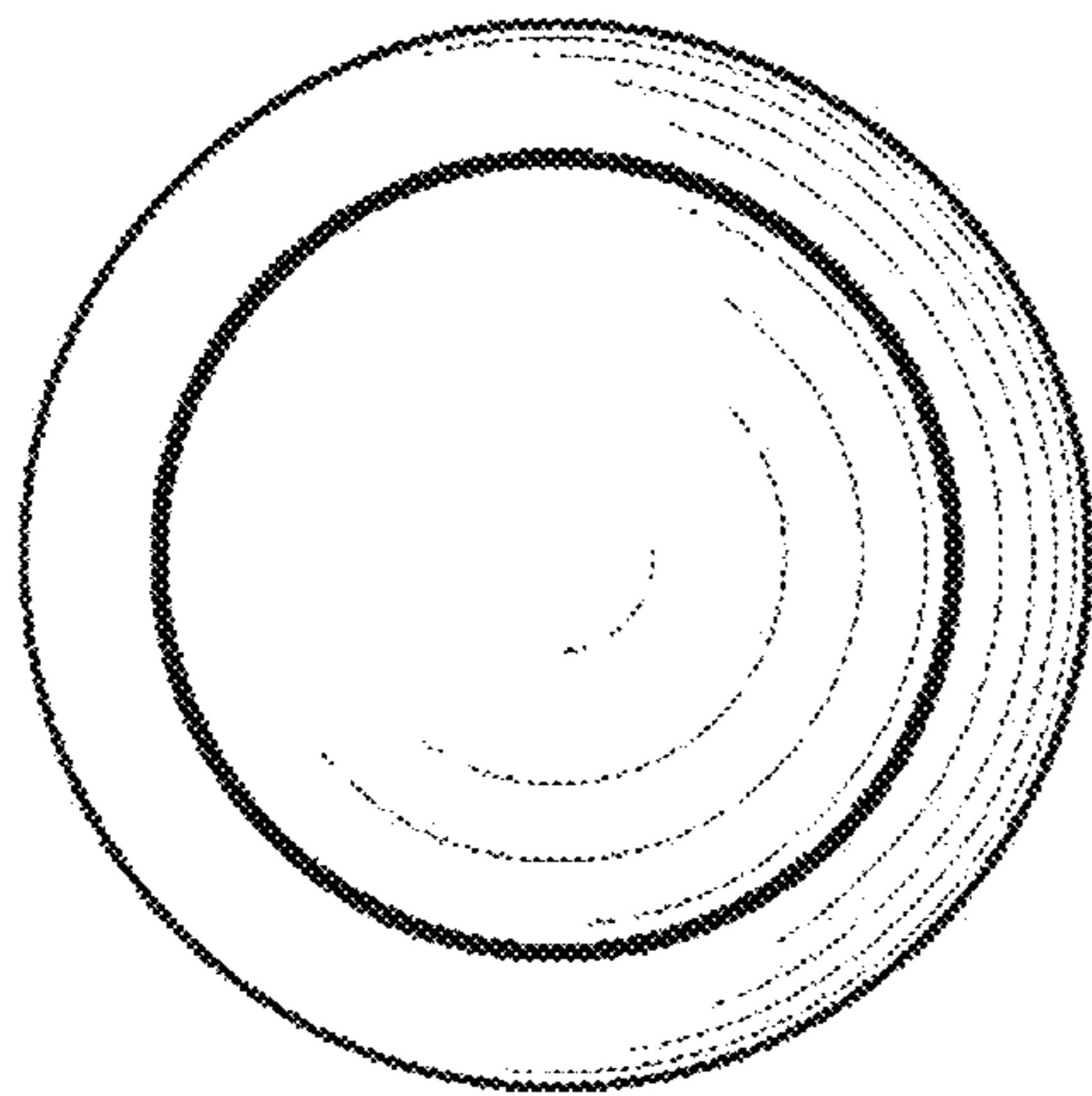

FIG. 3

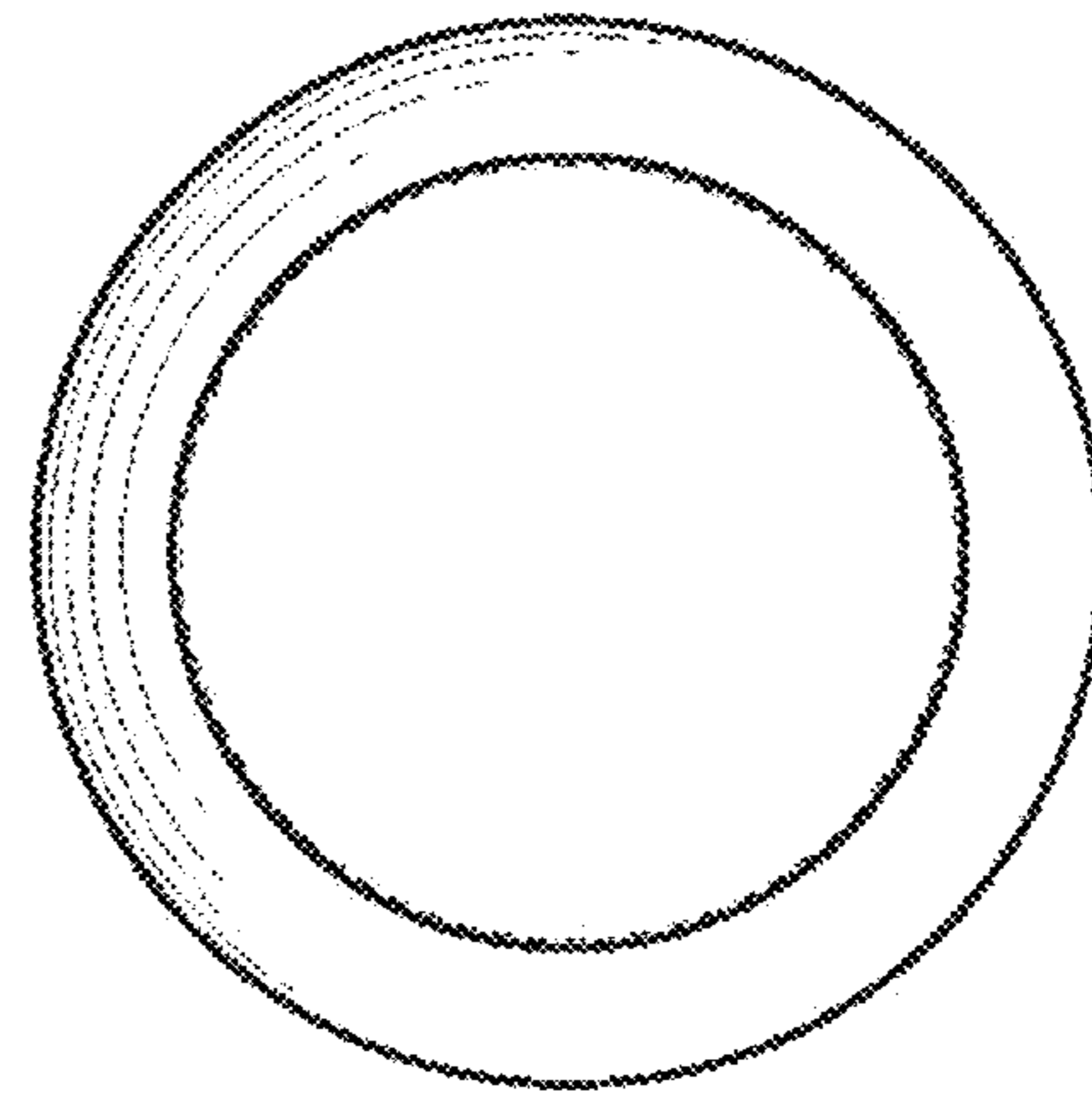

FIG. 4

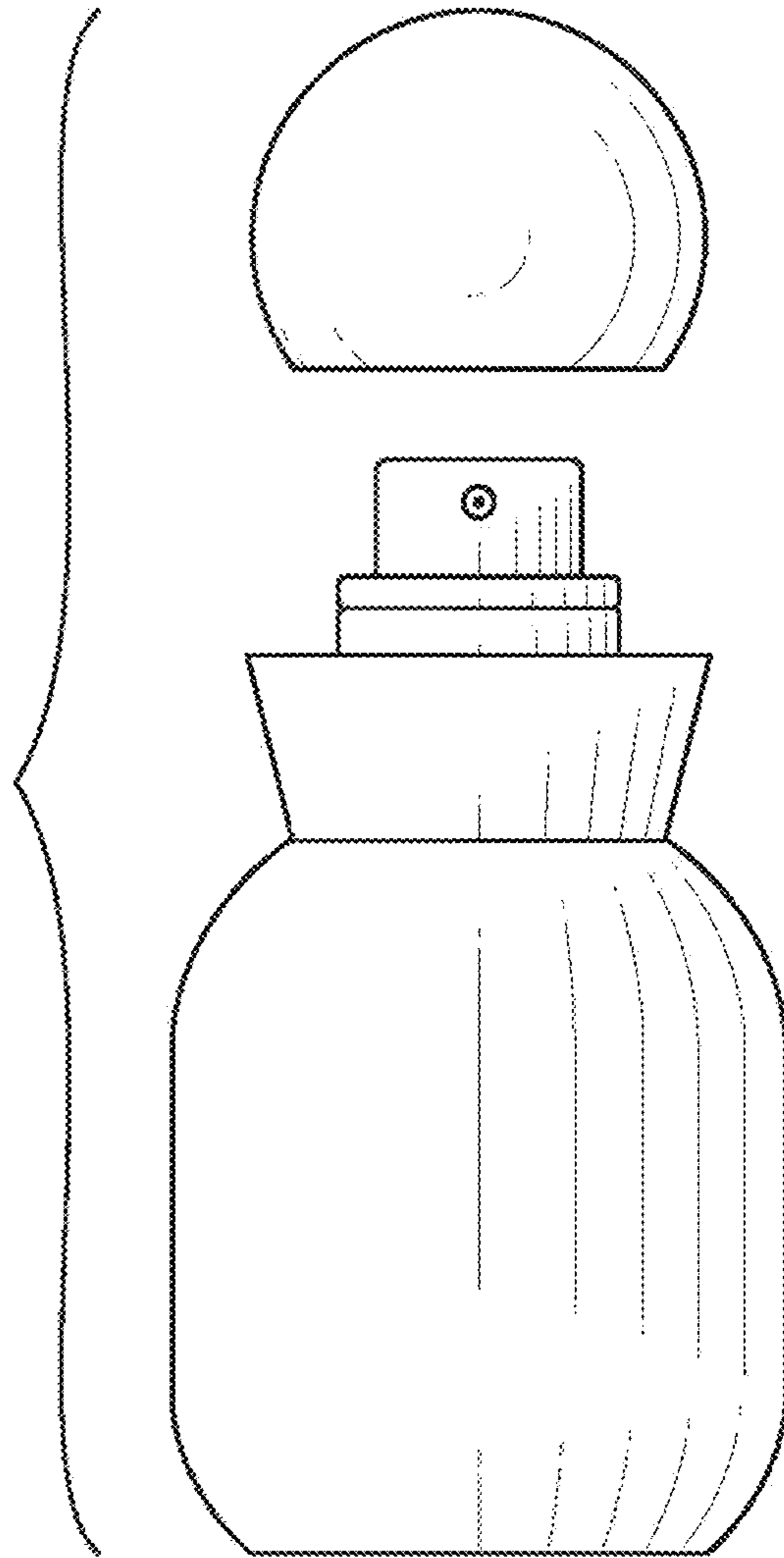

FIG. 5