



US00D926381S

(12) **United States Design Patent** (10) **Patent No.:** **US D926,381 S**  
**Sun** (45) **Date of Patent:** **\*\* Jul. 27, 2021**

(54) **COMPACT**  
(71) Applicant: **AMOREPACIFIC CORPORATION,**  
Seoul (KR)  
(72) Inventor: **Hwajung Sun,** Seoul (KR)  
(73) Assignee: **AMOREPACIFIC CORPORATION,**  
Seoul (KR)  
(\*\*) Term: **15 Years**  
(21) Appl. No.: **29/697,066**  
(22) Filed: **Jul. 3, 2019**

(30) **Foreign Application Priority Data**  
Apr. 8, 2019 (KR) ..... 30-2019-0016398  
(51) **LOC (13) Cl.** ..... **28-03**  
(52) **U.S. Cl.**  
USPC ..... **D28/82**  
(58) **Field of Classification Search**  
USPC ..... D28/64.1-64.7, 73, 76-82, 99;  
D9/503-505, 722, 737, 756, 759, 529  
CPC ..... A45D 33/006; A45D 33/003; A45D  
33/04-33; A45D 33/025; A45D 33/02;  
A45D 33/20; A45D 33/22; A45D 33/24;  
A45D 33/26; A45D 33/18; A45D 40/22;  
A45D 40/222; A45D 40/24; A45D  
33/008; A45D 42/00; A45D 42/04  
See application file for complete search history.

(56) **References Cited**  
**U.S. PATENT DOCUMENTS**  
D342,808 S \* 12/1993 Bakic ..... D28/82  
D344,817 S \* 3/1994 Chen ..... D28/82

D432,267 S \* 10/2000 Wardlaw ..... D28/78  
D463,628 S \* 9/2002 Thorpe ..... D28/82  
D468,058 S \* 12/2002 Thorpe ..... D28/82  
D507,078 S \* 7/2005 Greenfield ..... D28/82  
D537,985 S \* 3/2007 Bakic ..... D28/82  
D724,786 S \* 3/2015 Jung ..... D28/82  
D742,070 S \* 10/2015 Park ..... D28/82  
D777,984 S \* 1/2017 Son ..... D28/82  
D788,371 S \* 5/2017 Lee ..... D28/82  
D792,026 S \* 7/2017 Chertoff ..... D28/82  
D793,624 S \* 8/2017 Hwang ..... D28/82  
D817,551 S \* 5/2018 Montoli ..... B65D 43/166  
D28/82  
D846,195 S \* 4/2019 Kang ..... D28/82

\* cited by examiner  
*Primary Examiner* — Jennifer Rivard  
*Assistant Examiner* — Alison M Ofstun  
(74) *Attorney, Agent, or Firm* — Merchant & Gould P.C.

(57) **CLAIM**  
The ornamental design for a compact, as shown and described.

**DESCRIPTION**  
FIG. 1 is a perspective view of a compact showing my new design;  
FIG. 2 is a front elevation view;  
FIG. 3 is a rear elevation view;  
FIG. 4 is a left side view;  
FIG. 5 is a right side view;  
FIG. 6 is a top plan view; and,  
FIG. 7 is a bottom plan view.  
In the drawings, the broken lines illustrate portions of the article which form no part of the claimed design.

**1 Claim, 5 Drawing Sheets**

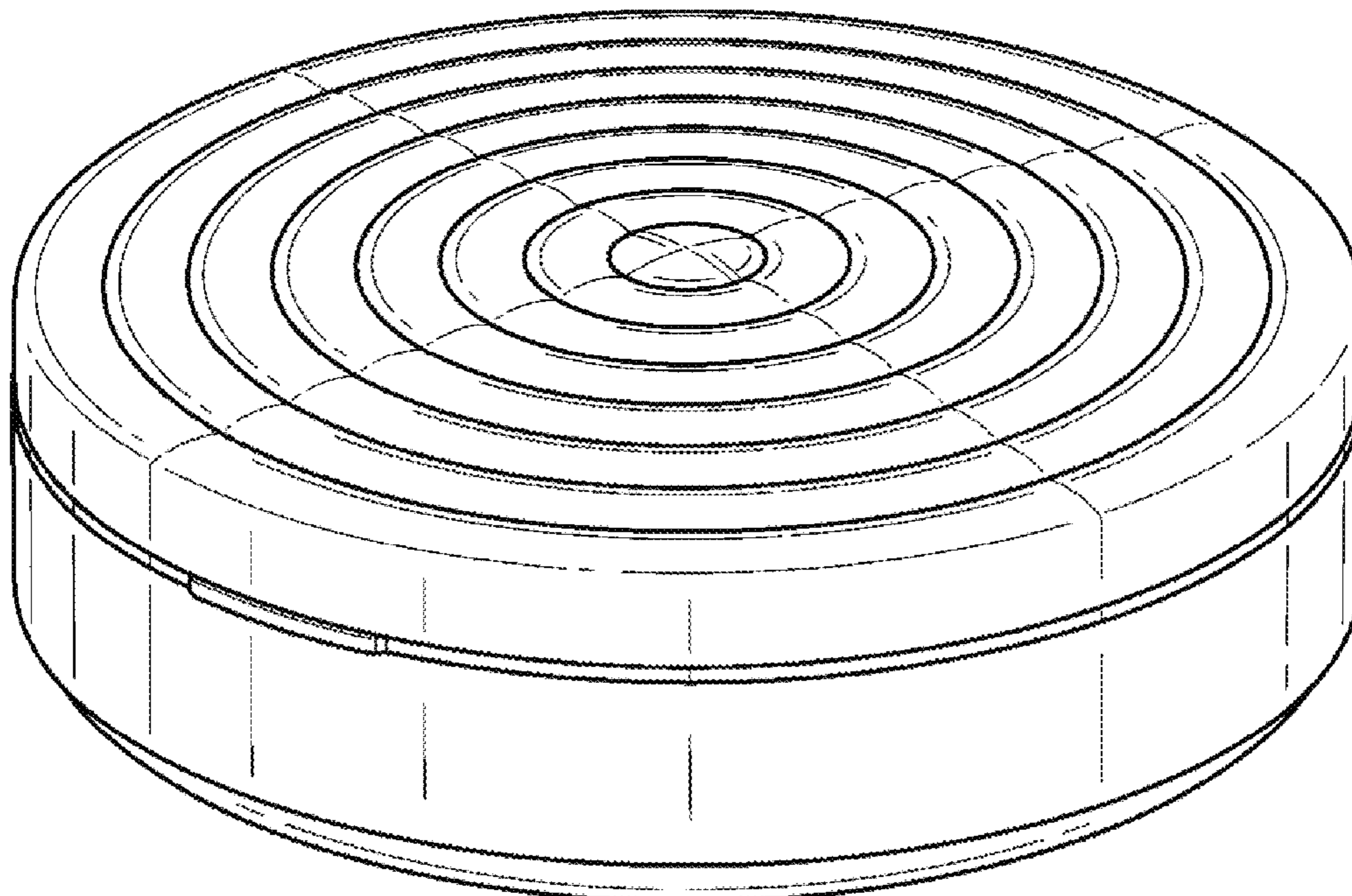

**Fig. 1**

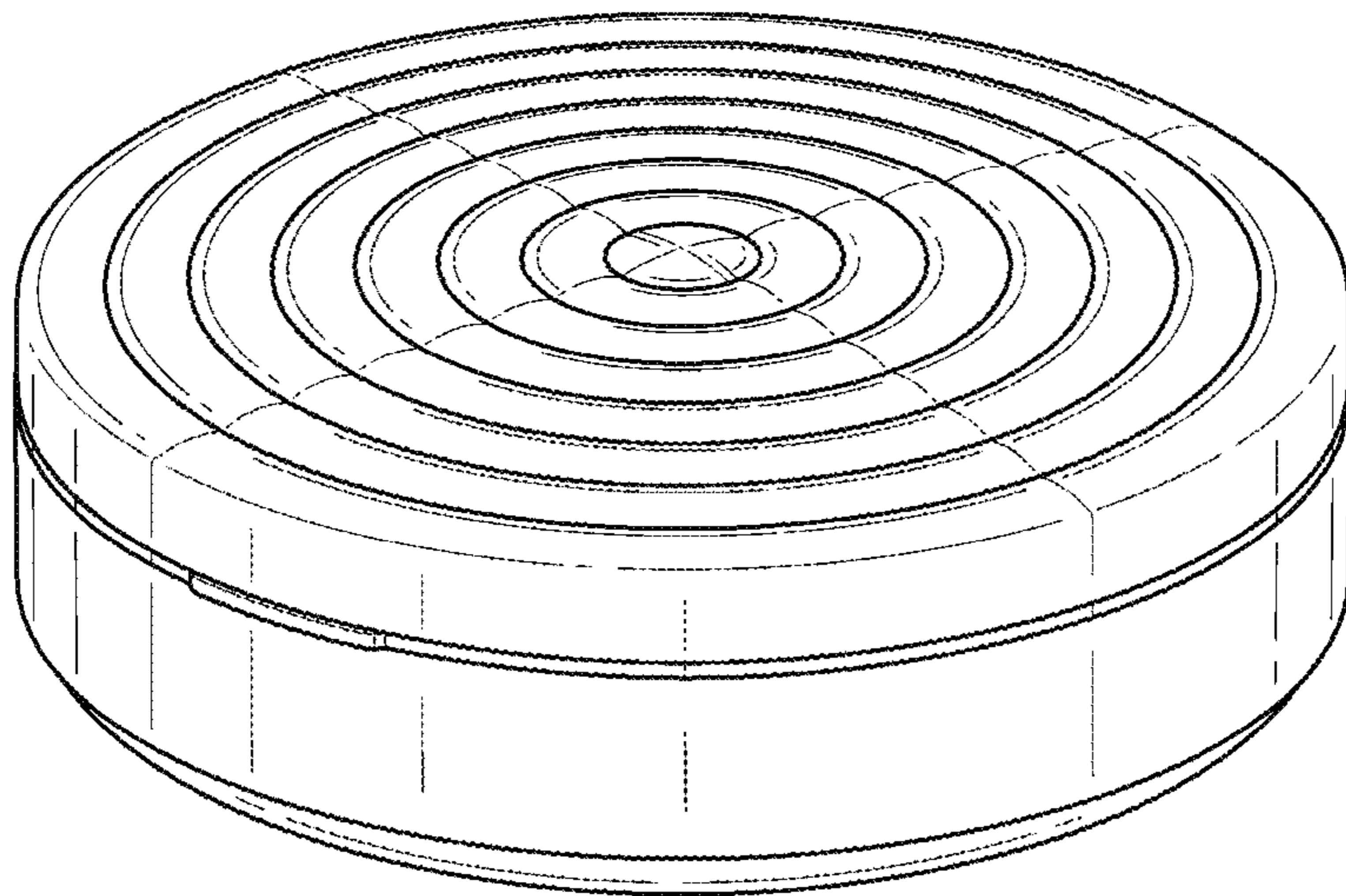

**Fig. 2**

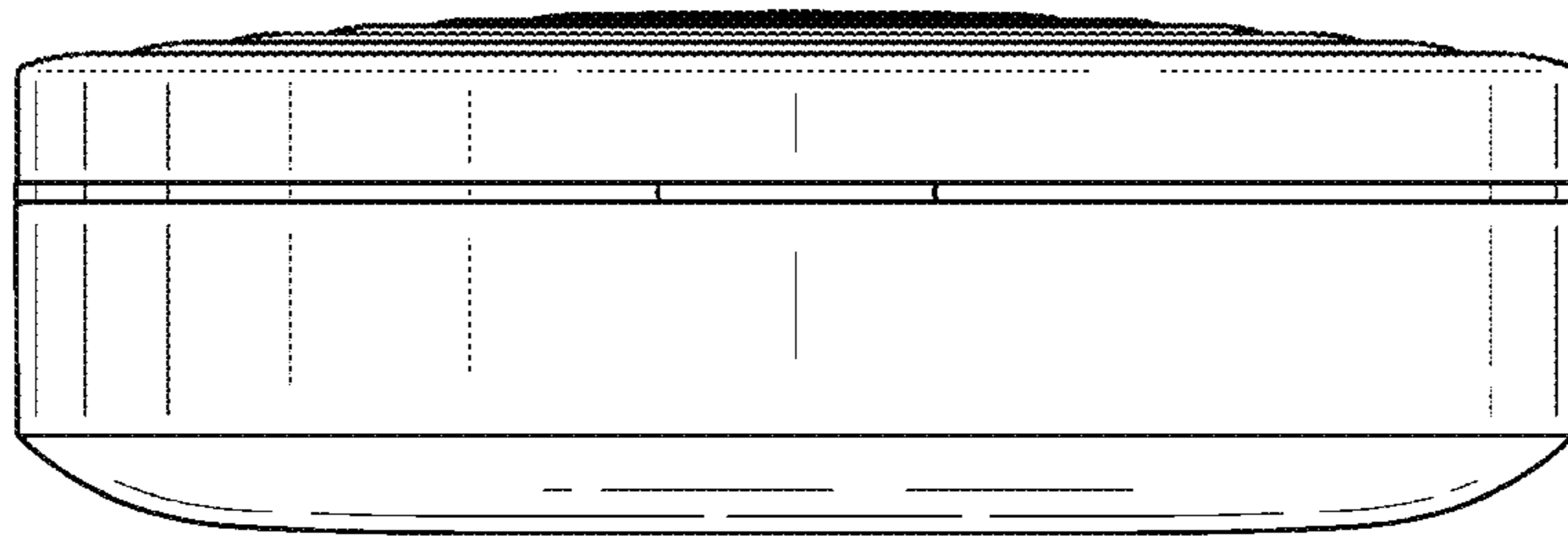

**Fig. 3**

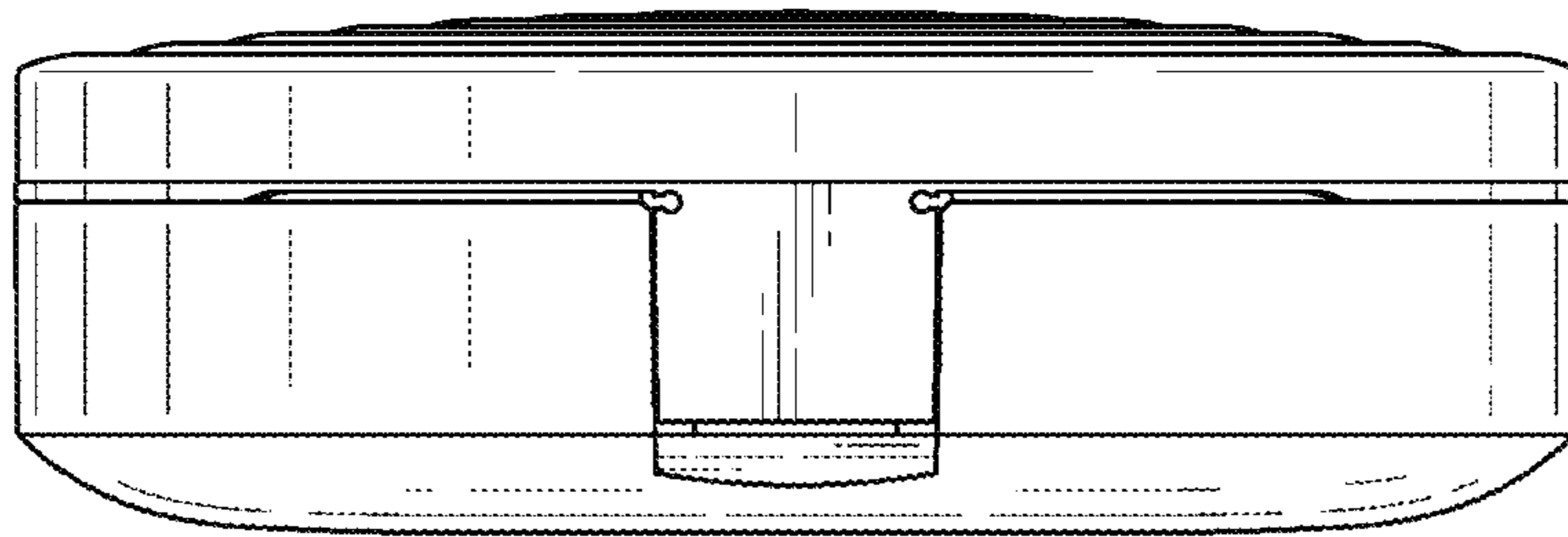

**Fig. 4**

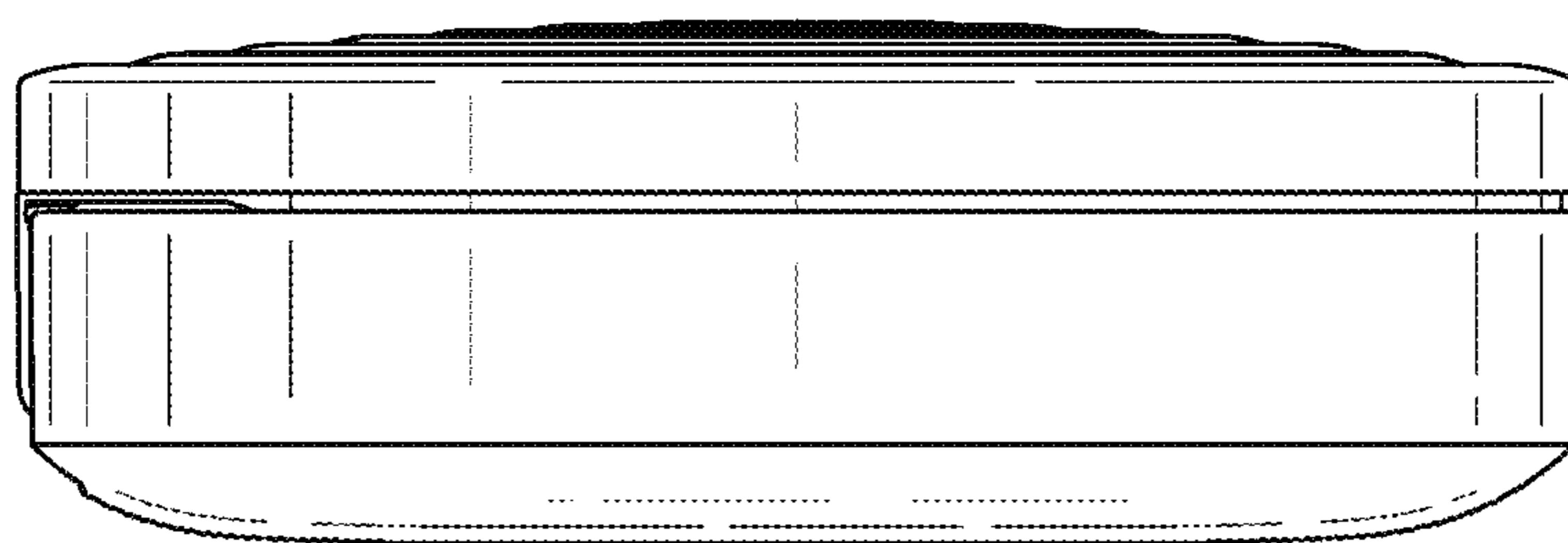

**Fig. 5**

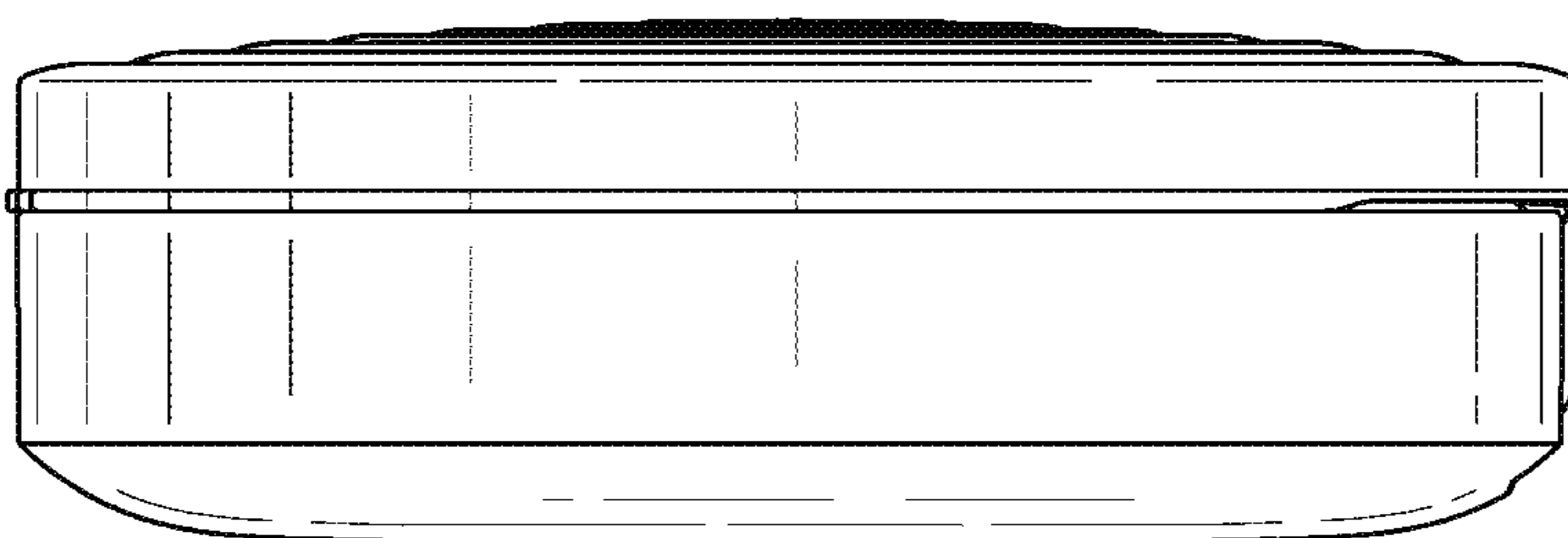

**Fig. 6**

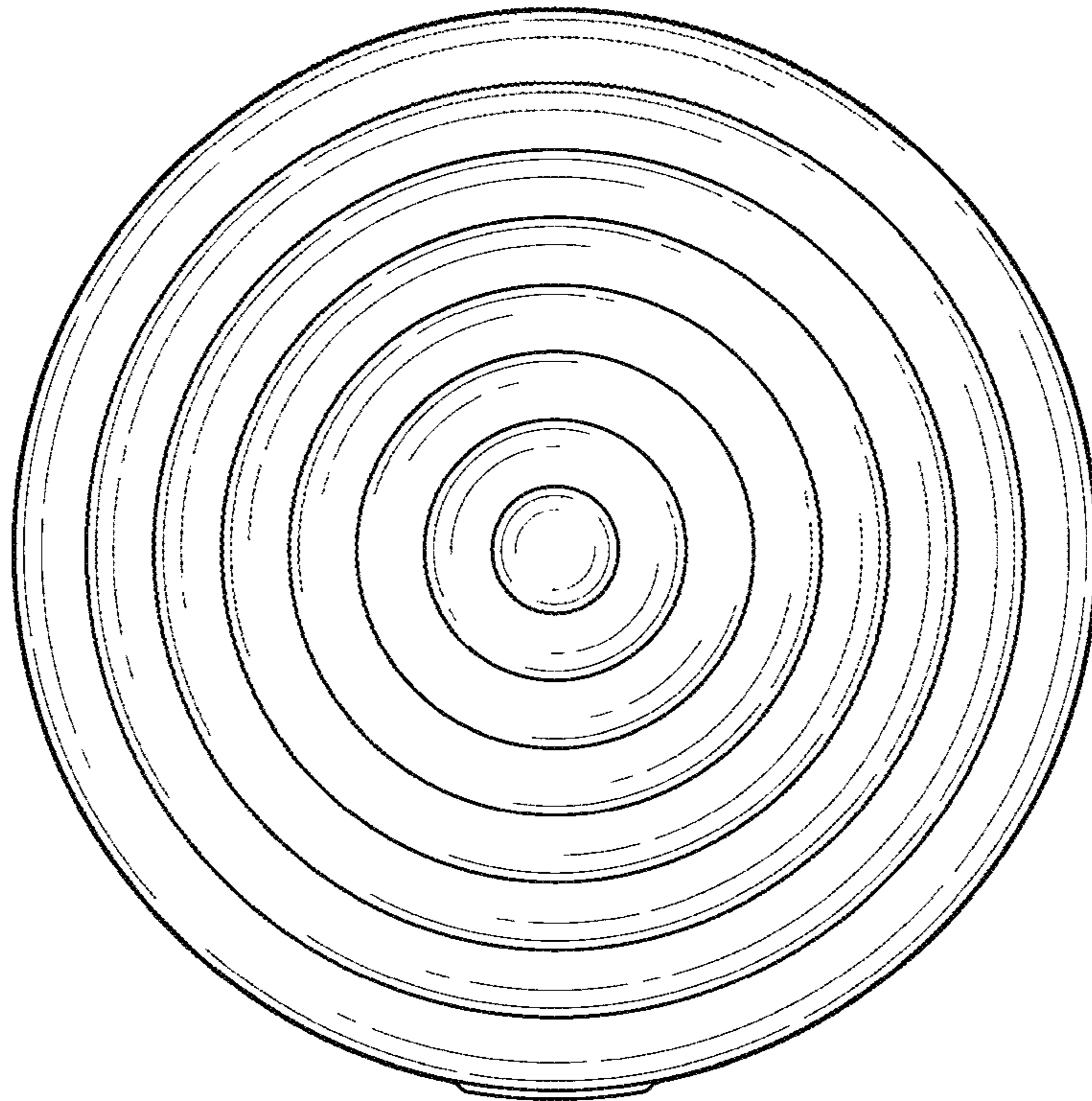



Fig. 7

