



US00D925441S

(12) **United States Design Patent** (10) **Patent No.:** **US D925,441 S**  
**Nakano et al.** (45) **Date of Patent:** **\*\* Jul. 20, 2021**

(54) **DATA TRANSMITTER WITH SOLAR CELL AND SENSOR**

FOREIGN PATENT DOCUMENTS

(71) Applicants: **SHARP KABUSHIKI KAISHA**, Sakai (JP); **KOBATA GAUGE MANUFACTURING CO., LTD.**, Osaka (JP)

CN 305240412 S 7/2019  
CN 305240413 S 7/2019

(Continued)

(72) Inventors: **Masayuki Nakano**, Sakai (JP); **Satoshi Shimizu**, Sakai (JP); **Tomohisa Yoshie**, Sakai (JP); **Iwao Kobata**, Osaka (JP); **Yoshiyuki Nakai**, Osaka (JP); **Daisuke Toyoshima**, Osaka (JP)

Petrala Solar Lantern Lights Panel Replacement Top. (online) 12 pgs. Available Dec. 6, 2018. [retrieved Oct. 2, 2020] [https://www.amazon.com/Petrala-Lantern-Replacement-Outdoor-Lanterns/dp/B07L687LCX?ref\\_ast\\_sto\\_dp](https://www.amazon.com/Petrala-Lantern-Replacement-Outdoor-Lanterns/dp/B07L687LCX?ref_ast_sto_dp)\*

(Continued)

(73) Assignees: **Sharp Kabushiki Kaisha**, Sakai (JP); **Kobata Gauge Manufacturing Co., Ltd.**, Osaka (JP)

*Primary Examiner* — Marie D. Fast Horse

(74) *Attorney, Agent, or Firm* — Nixon & Vanderhye P.C.

(\*\*) Term: **15 Years**

(57) **CLAIM**

The ornamental design for a data transmitter with solar cell and sensor, as shown and described.

(21) Appl. No.: **29/677,859**

(22) Filed: **Jan. 24, 2019**

**DESCRIPTION**

(30) **Foreign Application Priority Data**

Jul. 24, 2018 (JP) ..... 2018-016148

(51) **LOC (13) Cl.** ..... **13-02**

(52) **U.S. Cl.**  
USPC ..... **D13/102**; D10/80; D14/358

(58) **Field of Classification Search**  
USPC ... D14/140.1, 240, 242, 358, 125, 129, 130, D14/140, 142, 155, 167, 168, 172, 188,  
(Continued)

FIG. 1 is a front, right, top perspective view of a data transmitter with solar cell and sensor according to our design;

FIG. 2 is a front elevation view of the data transmitter with solar cell and sensor of FIG. 1;

FIG. 3 is a rear elevation view of the data transmitter with solar cell and sensor of FIG. 1;

FIG. 4 is a top plan view of the data transmitter with solar cell and sensor of FIG. 1;

FIG. 5 is a bottom plan view of the data transmitter with solar cell and sensor of FIG. 1;

FIG. 6 is a right side elevation view of the data transmitter with solar cell and sensor of FIG. 1; and,

FIG. 7 is a left side elevation view of the data transmitter with solar cell and sensor of FIG. 1.

The broken lines shown in the drawings illustrate portions of the data transmitter with solar cell and sensor that form no part of the claimed design.

(56) **References Cited**

U.S. PATENT DOCUMENTS

1,209,998 A \* 12/1916 Pinckert ..... A44C 21/00  
40/27.5  
1,553,742 A \* 9/1925 Blatter ..... G01F 23/363  
338/33

(Continued)

**1 Claim, 7 Drawing Sheets**

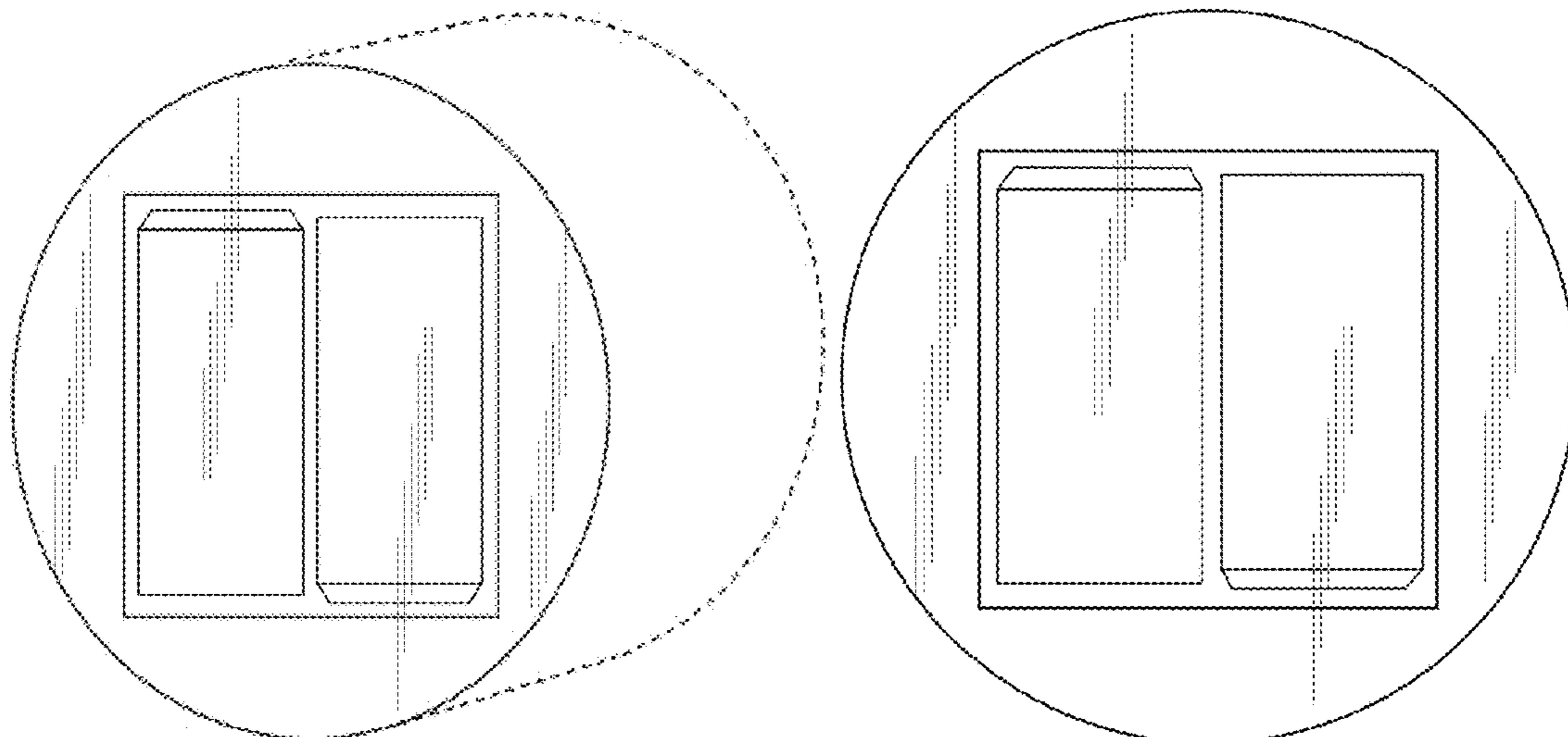

(58) **Field of Classification Search**

USPC ..... D14/195, 299, 496, 348, 351, 356, 357,  
 D14/197, 198, 230; D13/110, 123, 152,  
 D13/158, 162, 162.1, 163, 168, 184, 199,  
 D13/108, 179, 102; D10/104.1, 106.1,  
 D10/106.6, 116.1, 61, 64, 75, 106.9, 80  
 CPC ... H04W 88/00; H04W 88/005; H04W 88/02;  
 H04W 88/08; H04W 88/085; H04W  
 88/10; H04W 88/12; H04W 88/14; H04W  
 88/16; H04W 88/18; H04W 4/00; H01Q  
 1/02; H01Q 1/2291; H01Q 1/246; H04B  
 1/38; F16B 47/00; G06F 21/31; G06F  
 21/44

See application file for complete search history.

(56) **References Cited**

U.S. PATENT DOCUMENTS

2,340,703 A \* 2/1944 Schwabacher ..... H02G 3/0658  
 439/449  
 2,627,533 A \* 2/1953 Jensen ..... H01M 2/06  
 429/121  
 D187,328 S \* 3/1960 Gordon et al. .... D10/80  
 D248,628 S \* 7/1978 Schwartz ..... D10/75  
 4,099,517 A 7/1978 McRae  
 D257,893 S 1/1981 Millhollen  
 4,293,808 A 10/1981 Varadi  
 4,315,498 A 2/1982 Devin  
 D309,786 S \* 8/1990 Chien ..... D26/67  
 D329,024 S \* 9/1992 Marks ..... D10/80  
 D344,733 S 3/1994 Walthers  
 D346,170 S \* 4/1994 Tang ..... D14/230  
 D347,584 S \* 6/1994 Vogelpohl ..... D10/49  
 5,453,729 A \* 9/1995 Chu ..... F21S 9/037  
 340/321  
 D378,435 S \* 3/1997 Trombley ..... D26/110  
 D378,578 S \* 3/1997 Eberhardt ..... D10/104.1  
 D380,191 S 6/1997 White  
 D380,441 S 7/1997 Fukuhara  
 5,745,262 A \* 4/1998 Tatsumi ..... H04N 1/40056  
 348/362  
 D397,233 S \* 8/1998 Bassford ..... D10/104.1  
 6,238,218 B1 \* 5/2001 Baffert ..... H01R 24/50  
 439/581  
 D453,329 S \* 2/2002 Muramatsu ..... D14/230  
 D453,511 S \* 2/2002 Goto ..... D14/356  
 D456,807 S \* 5/2002 Floyd ..... D14/356  
 D464,347 S \* 10/2002 Floyd ..... D14/356  
 D466,866 S 12/2002 Stack  
 D468,296 S \* 1/2003 Graceffa ..... D13/164  
 D477,312 S 7/2003 Dugas  
 D484,097 S \* 12/2003 Drane ..... D13/139.4  
 D496,038 S \* 9/2004 Floyd ..... D14/356  
 6,812,398 B2 \* 11/2004 Yueh ..... F21S 9/032  
 136/246  
 D507,657 S \* 7/2005 Neel ..... D10/102  
 D563,327 S 3/2008 Horio  
 D580,800 S 11/2008 Hauk  
 D588,534 S 3/2009 Sharma  
 D589,013 S \* 3/2009 Pozin ..... D14/127  
 D590,604 S \* 4/2009 Pozin ..... D6/302  
 D606,489 S 12/2009 Sasaada  
 D611,460 S \* 3/2010 Chao ..... D14/230  
 D621,985 S \* 8/2010 Sanoner ..... D26/67  
 D631,566 S \* 1/2011 Egawa ..... D26/1  
 D642,722 S \* 8/2011 Oberpriller ..... D26/67  
 D650,334 S \* 12/2011 Matsuoka ..... D13/133  
 D658,605 S \* 5/2012 Egawa ..... D13/180  
 D664,213 S \* 7/2012 Sogabe ..... D14/356  
 D669,848 S \* 10/2012 Andresen ..... D13/102  
 D670,239 S \* 11/2012 Kannou ..... D13/102  
 D671,921 S \* 12/2012 Beall ..... D14/230  
 D683,251 S \* 5/2013 Dumas ..... D10/104.2  
 D687,590 S \* 8/2013 Chilton ..... D26/93

8,574,943 B2 11/2013 Murray  
 D695,679 S 12/2013 Eridoh  
 D701,827 S 4/2014 Turk  
 D708,569 S 7/2014 Beckerman  
 D719,960 S \* 12/2014 Akana ..... D14/447  
 D738,275 S \* 9/2015 Tachiiri ..... D12/174  
 D748,639 S \* 2/2016 Khodapanah ..... D14/447  
 9,257,237 B2 2/2016 Okada  
 D761,198 S 7/2016 Hou  
 D761,736 S \* 7/2016 Imai ..... D13/154  
 D766,844 S \* 9/2016 Turksu ..... D13/168  
 D774,451 S 12/2016 Castillo-Aguilella  
 D774,934 S \* 12/2016 Akana ..... D10/104.1  
 D780,727 S \* 3/2017 Wang ..... D14/240  
 9,589,736 B2 3/2017 Matsumoto  
 D786,724 S \* 5/2017 Seagle, Jr. .... D10/106.1  
 D801,316 S \* 10/2017 Weber ..... D14/230  
 D804,059 S 11/2017 Labesque  
 D804,533 S \* 12/2017 Mangum ..... D14/496  
 D806,014 S 12/2017 Saitou  
 D806,931 S \* 1/2018 Hui ..... D26/102  
 D806,932 S \* 1/2018 Hui ..... D26/102  
 D806,933 S \* 1/2018 Hui ..... D26/102  
 D812,577 S \* 3/2018 Turksu ..... D10/104.1  
 D813,068 S \* 3/2018 Studer ..... D10/97  
 D820,238 S \* 6/2018 Boshernitzan ..... D14/218  
 D822,253 S \* 7/2018 Wu ..... D26/68  
 10,079,504 B2 \* 9/2018 Hui ..... E04H 4/1654  
 D854,950 S \* 7/2019 Seum ..... D10/53  
 D855,492 S \* 8/2019 Jones ..... D11/131  
 D860,958 S \* 9/2019 Lewis ..... D13/184  
 D865,859 S \* 11/2019 Ben Avi ..... D14/385  
 D867,346 S \* 11/2019 Hofstede ..... D14/222  
 D869,697 S \* 12/2019 Kasuga ..... D26/28  
 D882,144 S \* 4/2020 Zhu ..... D26/67  
 D885,631 S \* 5/2020 Li ..... D26/67  
 D889,444 S \* 7/2020 Sakamoto ..... D14/230  
 D890,144 S \* 7/2020 Sakamoto ..... D14/230  
 D897,944 S \* 10/2020 Bevilacqua ..... D13/102  
 D897,945 S \* 10/2020 Zhou ..... D13/102  
 D898,660 S \* 10/2020 Zhou ..... D13/102  
 D898,661 S \* 10/2020 Zhou ..... D13/102  
 D899,352 S \* 10/2020 Gong ..... D13/102  
 D902,143 S \* 11/2020 Fukuda ..... D13/102  
 D903,583 S \* 12/2020 Bevilacqua ..... D13/102  
 D905,625 S \* 12/2020 Zhou ..... D13/102  
 D908,606 S \* 1/2021 Fukui ..... D13/102  
 D908,607 S \* 1/2021 Zhou ..... D13/102  
 D910,539 S \* 2/2021 Nakano ..... D13/102  
 2007/0201187 A1 8/2007 McGregor  
 2008/0011917 A1 \* 1/2008 Adams ..... F16B 47/00  
 248/205.5  
 2008/0123313 A1 5/2008 Horne  
 2008/0158865 A1 \* 7/2008 Chen ..... F21V 21/0824  
 362/183  
 2008/0314448 A1 12/2008 Kato  
 2011/0263067 A1 10/2011 Vaid  
 2018/0283630 A1 \* 10/2018 Soofer ..... F21S 9/035  
 2020/0138246 A1 \* 5/2020 Wegelin ..... G06F 21/44

FOREIGN PATENT DOCUMENTS

CN 305240415 S 7/2019  
 EM 005215001-0003 6/2018  
 JP D1131849 11/2001  
 JP D1161787 11/2002  
 JP D1290286 11/2006  
 JP D1390147 5/2010  
 JP D1390148 5/2010  
 JP D1462708 1/2013  
 JP D1469292 4/2013  
 JP D1490549 1/2014  
 JP D1593399 11/2017  
 JP D1627499 3/2019  
 JP D1627618 3/2019  
 JP D1632696 4/2019  
 JP D1636976 6/2019  
 JP D1637087 6/2019

(56)

**References Cited**

## FOREIGN PATENT DOCUMENTS

JP	D1637236	6/2019
JP	D1637250	6/2019
JP	D1638436	7/2019

## OTHER PUBLICATIONS

Antenna Transmitters and Solar Cells. (Design—© Questel) orbit.com. [online PDF] 30 pgs. Print Dates Range Jul. 21, 2017 through Sep. 27, 2019 [Oct. 3, 2020] <https://www.orbit.com/export/QPTUJ214/pdf2/75d42c1d-d199-413f-8d92-710b6727e733-170049.pdf>.\*

Half-cut cells—Photo from Hanwha Q Cells SPI 2017 booth. (online Image) 1 pg. Uploaded Sep. 2017 [Retrieved Feb. 4, 2021] <https://www.solarpowerworldonline.com/2018/10/what-is-a-half-cell-solar-panel/> img URL: <https://3vq5kdns38e1qxlmvqmrzsi-wpengine.netdna-ssl.com/wp-content/uploads/2017/09/hanwha-e15051835>.\*

MAGGIFT Solar Pathway Lights Replacement Top. (online) 7 pgs. Available Jan. 18, 2018. [retrieved Oct. 2, 2020] [https://www.amazon.com/MAGGIFT-Solar-Pathway-Lights-Replacement/dp/B07DF5QSJF?ref\\_=ast\\_sto\\_dp](https://www.amazon.com/MAGGIFT-Solar-Pathway-Lights-Replacement/dp/B07DF5QSJF?ref_=ast_sto_dp).\*

Design U.S. Appl. No. 29/677,846, filed Jan. 24, 2019, entitled “Communication Module With Solar Cell”.

Design U.S. Appl. No. 29/677,848, filed Jan. 24, 2019, entitled “Dye-Sensitized Solar Cell Module”.

Notice of Allowance dated Aug. 10, 2020 in Design U.S. Appl. No. 29/677,846.

Notice of Allowance dated Sep. 10, 2020 in Design U.S. Appl. No. 29/677,848.

Notice of Allowance dated Nov. 5, 2020 in U.S. Appl. No. 29/677,846.

Notice of Allowance dated Oct. 20, 2020 in U.S. Appl. No. 29/677,848.

\* cited by examiner

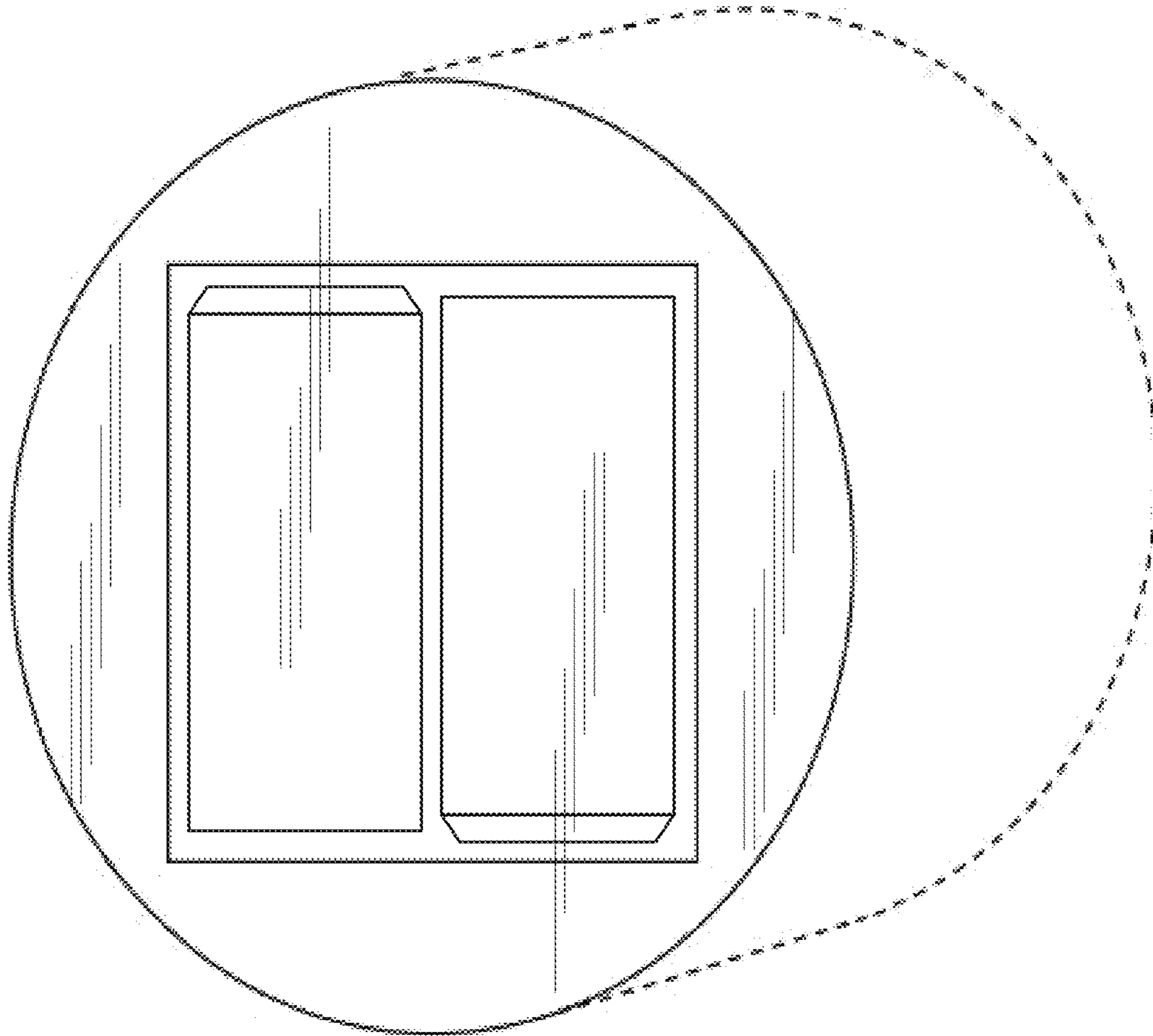

FIG. 1

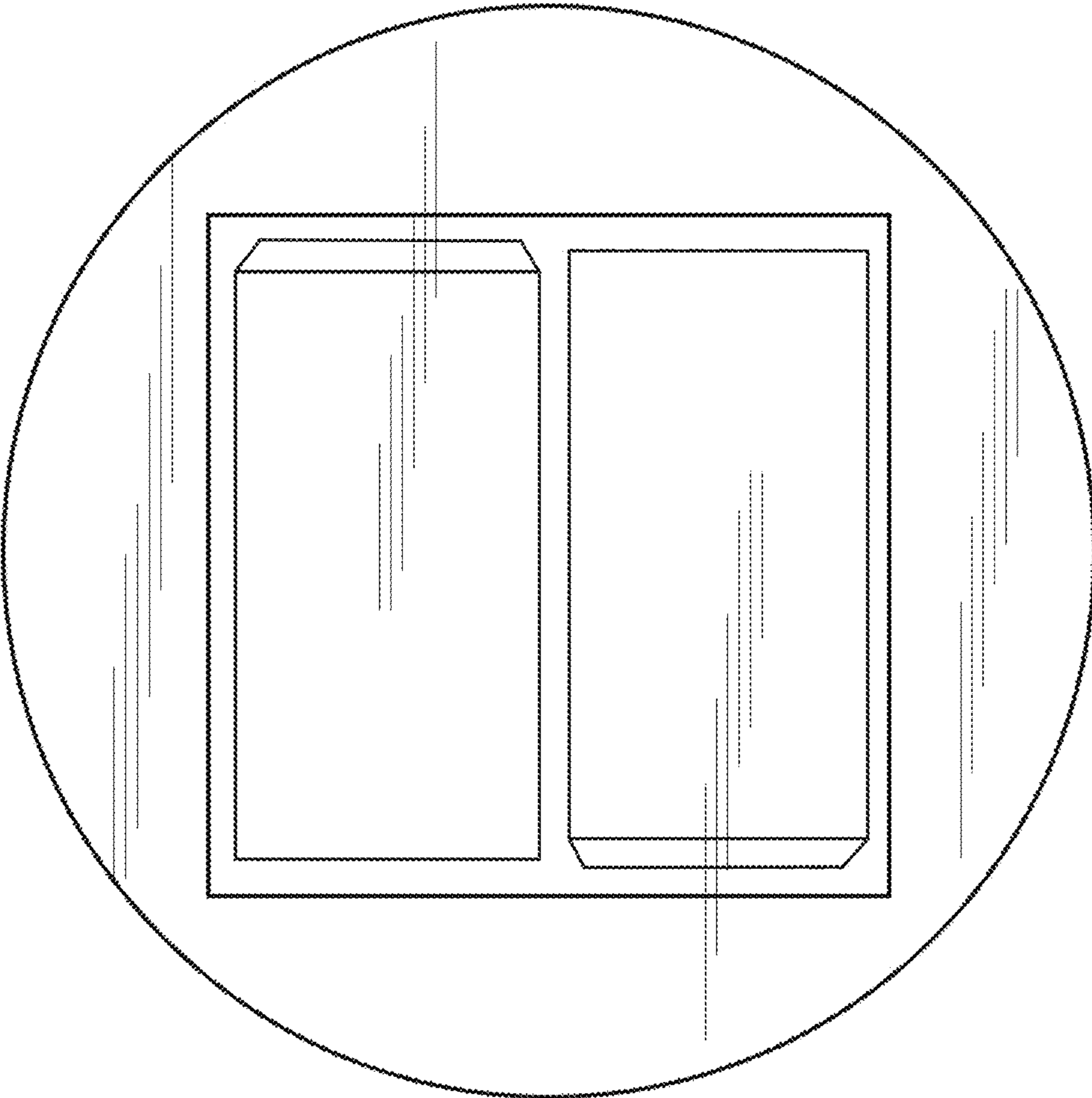

FIG. 2

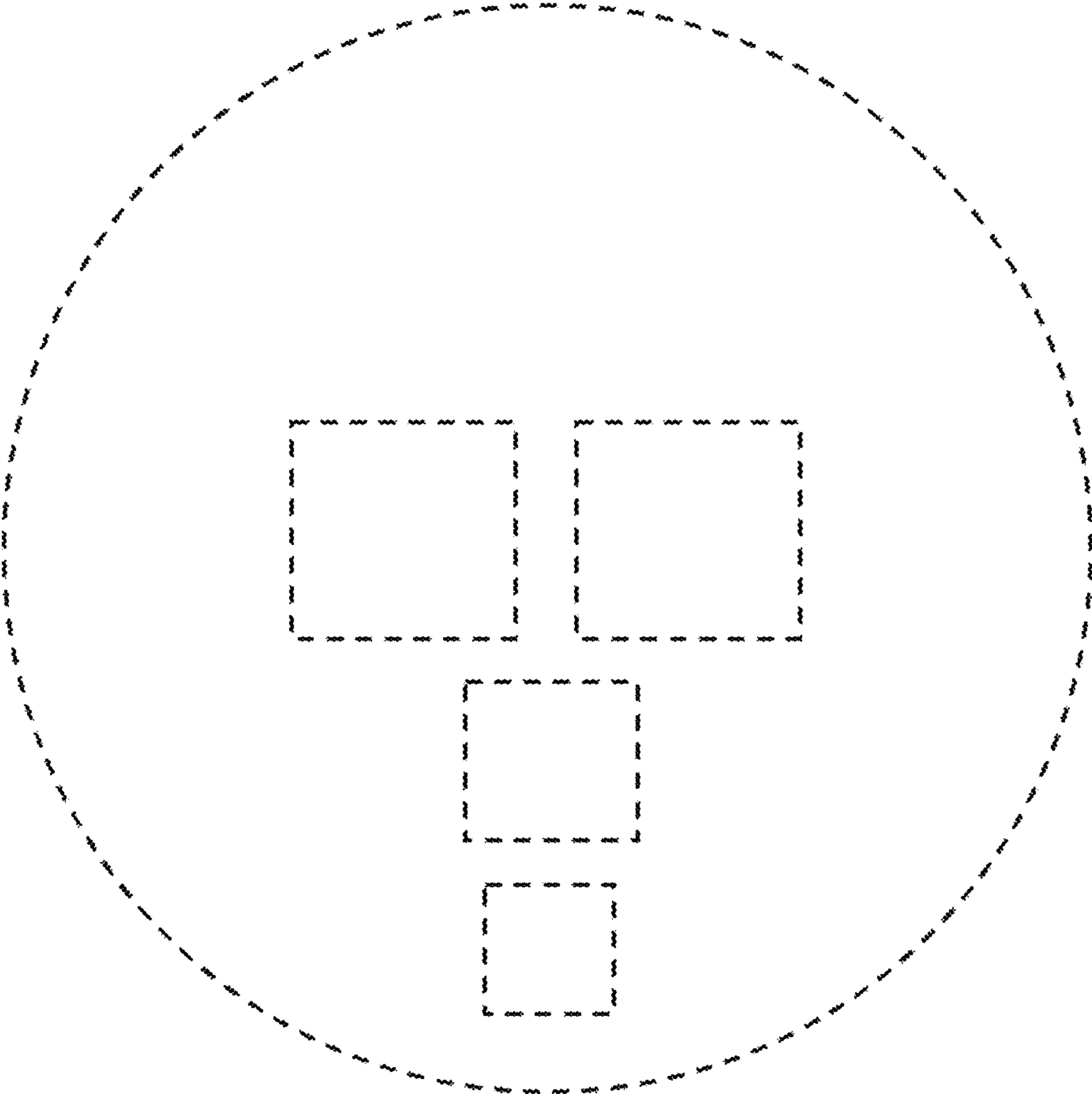

FIG. 3

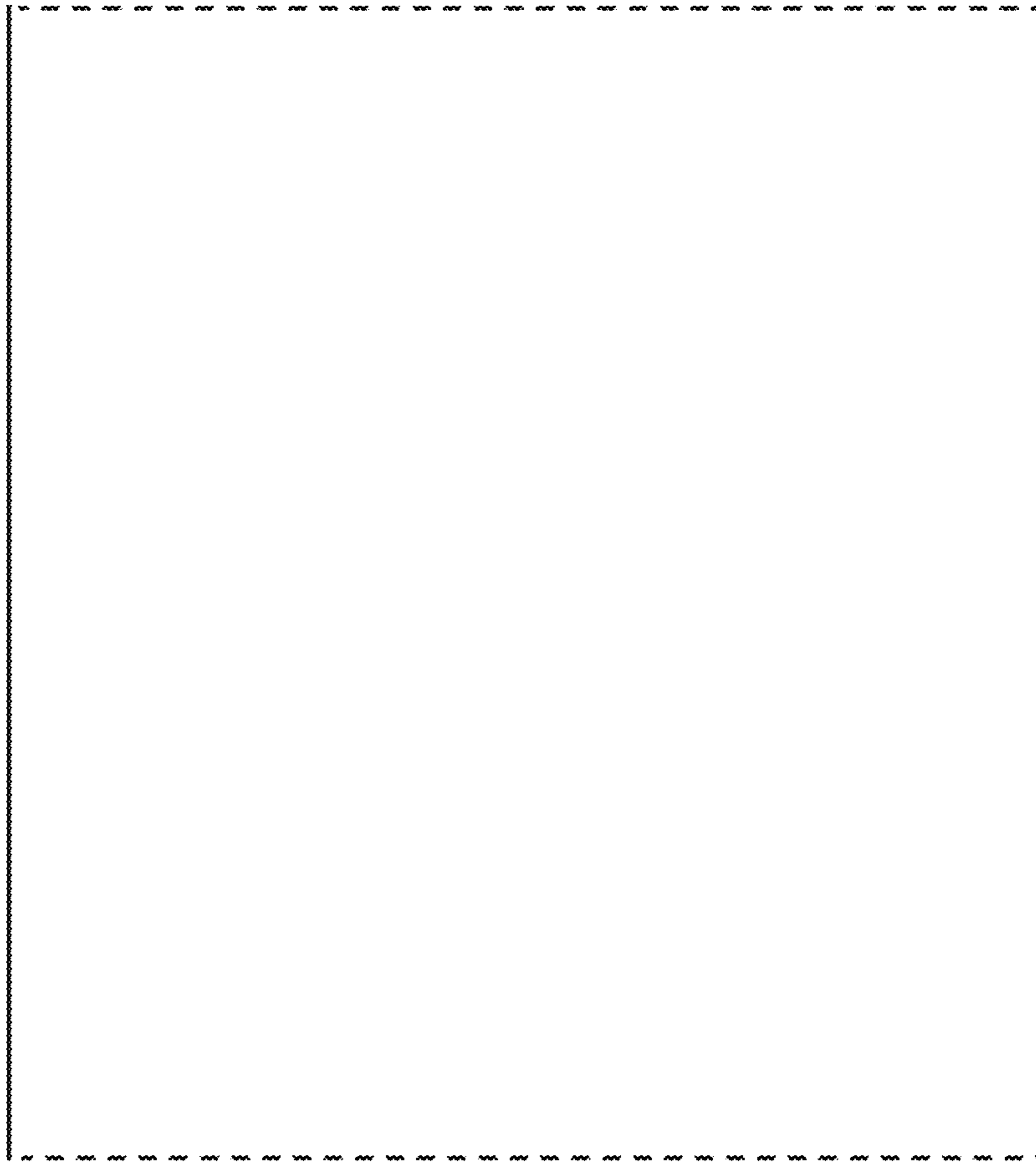

**FIG. 4**

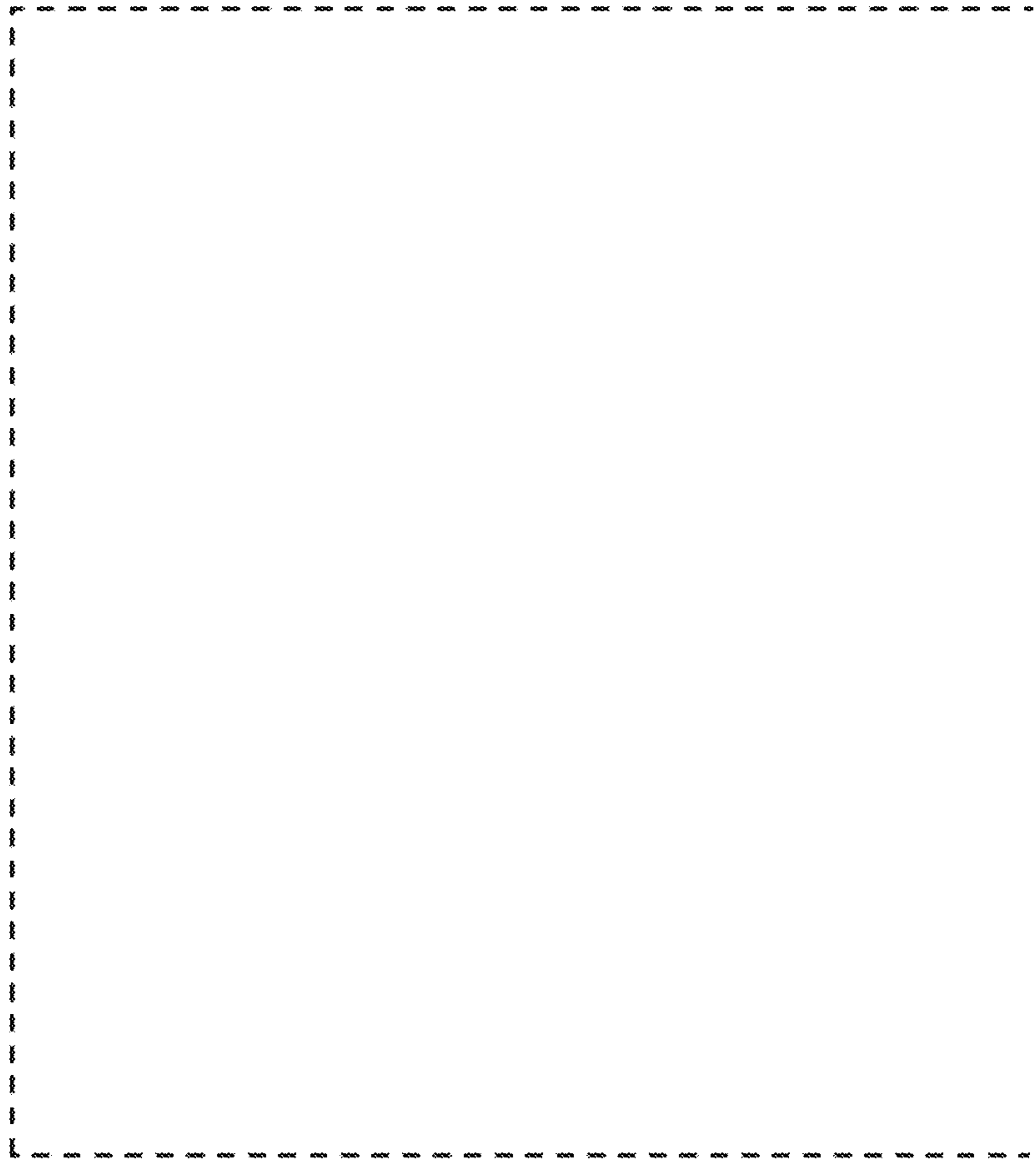

**FIG. 5**





**FIG. 6**



**FIG. 7**