



US00D924938S

(12) **United States Design Patent** (10) **Patent No.:** **US D924,938 S**
Lörner (45) **Date of Patent:** **** Jul. 13, 2021**

(54) **HOUSING PORTION FOR A HYDRAULIC PUMP**
(71) Applicant: **HAWE Hydraulik SE**, Aschheim (DE)
(72) Inventor: **Gerhard Lörner**, Zorneding (DE)
(73) Assignee: **HAWE Hydraulik SE**, Aschheim (DE)
(**) Term: **15 Years**

D244,681 S 6/1977 Bell
D244,942 S * 7/1977 Bobrovniczky D25/120
D279,608 S * 7/1985 Carey D25/126
4,597,717 A 7/1986 Mohr
D291,009 S * 7/1987 Weilow D25/120
D295,753 S 5/1988 LaBair
D315,027 S * 2/1991 Abbestam D25/124
5,013,198 A 5/1991 Schultz
D335,291 S 5/1993 Schnell
D356,283 S * 3/1995 Christensen D12/223
D370,683 S 6/1996 Stahlman

(Continued)

(21) Appl. No.: **29/769,887**
(22) Filed: **Feb. 8, 2021**

Related U.S. Application Data

(63) Continuation-in-part of application No. 29/722,188, filed on Jan. 27, 2020.

Foreign Application Priority Data

Jul. 29, 2019 (EM) 006653234-0007

(51) **LOC (13) Cl.** **15-02**

(52) **U.S. Cl.**
USPC **D15/7; D13/179**

(58) **Field of Classification Search**
USPC D15/7, 9, 143, 148–149, 199; D23/225, D23/231–233, 235; D10/85; D14/188; D13/110, 162, 179, 184
CPC F15B 15/16; F15B 15/26; F15B 15/1414; F15B 15/1919; F15B 15/14; F15B 15/00; F15B 15/08; F15B 15/18; F15B 15/20; F02M 37/04; F04D 29/4286
See application file for complete search history.

(56) **References Cited**

U.S. PATENT DOCUMENTS

D194,516 S 2/1963 Cordis
3,131,792 A * 5/1964 Groneman A47F 11/02 52/38
3,360,930 A 1/1968 Haag

OTHER PUBLICATIONS

Deshe Aluminum, Top Grade Aluminium extruded heat sink Architectural Aluminium, (site visited Mar. 25, 2021), Global Market Website, URL:<<http://www.globalmarket.com/product-info/top-grade-aluminium-extruded-heatsink-architectural-aluminium-11544677.html>> (Year: 2021).*

(Continued)

Primary Examiner — Sheryl Lane
Assistant Examiner — Mark T. Philipps
(74) *Attorney, Agent, or Firm* — Aslan Law, P.C.

(57) **CLAIM**

The ornamental design for a housing portion for a hydraulic pump, as shown and described.

DESCRIPTION

FIG. 1 is a first perspective view of a housing portion for a hydraulic pump showing my new design; FIG. 2 is a front side view thereof; NOTE: the front, left, and right sides views are the same. FIG. 3 is a rear view thereof; and, FIG. 4 is a top view thereof; a bottom view is a mirror image of the top view. The dashed line in FIG. 1 represents an artifact of the manufacturing process, and forms no part of the design.

1 Claim, 4 Drawing Sheets

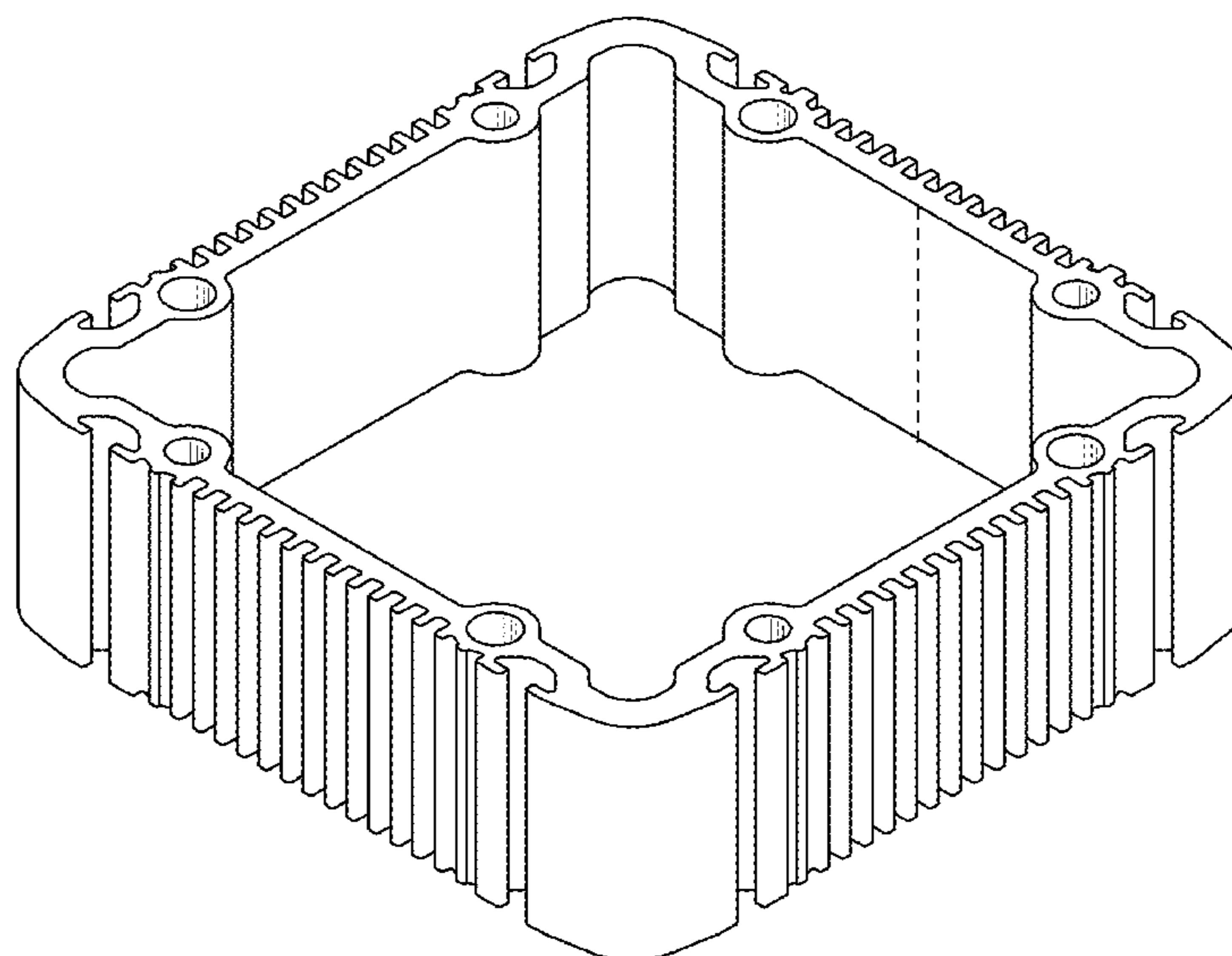

(56)

References Cited

U.S. PATENT DOCUMENTS

5,555,789 A 9/1996 Rosengren
 D387,333 S * 12/1997 Pellow D13/162
 D408,420 S 4/1999 Buter
 D424,217 S * 5/2000 Beachy D25/126
 D427,669 S * 7/2000 Ruuska D23/266
 D428,617 S 7/2000 Hariwara
 6,089,111 A 7/2000 Machijima
 6,592,336 B1 7/2003 Hirano
 D479,246 S 9/2003 Leu
 D480,405 S 10/2003 Kleffmann
 6,828,782 B2 12/2004 Nagai
 D516,583 S 3/2006 Strong
 D533,957 S * 12/2006 Barozzini D26/118
 D537,777 S * 3/2007 Hargreaves D13/110
 7,383,670 B1 * 6/2008 Meyers E04F 13/081
 156/71
 D616,114 S * 5/2010 Harder D25/126
 D651,739 S * 1/2012 Trzesniowski D26/138
 D666,743 S * 9/2012 Teffenhart, Jr. D25/124
 D685,403 S 7/2013 Mangold
 D694,721 S * 12/2013 Peng D13/179
 8,863,645 B2 10/2014 Andersen
 9,212,655 B2 12/2015 Neumair
 D747,127 S * 1/2016 Chang D6/709
 D760,805 S 7/2016 Monden
 9,493,329 B2 11/2016 Lemke
 D782,107 S * 3/2017 Klus D26/138
 D788,329 S * 5/2017 Bizzarri E04H 17/1447
 D25/133
 D805,560 S 12/2017 Kudo
 D818,190 S * 5/2018 Trzesniowski D26/138
 D818,193 S * 5/2018 Trzesniowski D26/138
 D819,700 S 6/2018 Kudo
 D845,516 S * 4/2019 Yuan D25/121
 D871,457 S 12/2019 Ikari
 D888,770 S 6/2020 Mizutani
 D888,771 S 6/2020 Mizutani

D888,774 S 6/2020 Asahara
 D900,166 S * 10/2020 Nemoto D15/7
 D903,717 S 12/2020 Schaefer
 2003/0070428 A1 4/2003 Heusser
 2004/0114329 A1 * 6/2004 Shih-Tsung H01L 23/4093
 361/704
 2005/0091972 A1 5/2005 Redman
 2006/0228235 A1 10/2006 Neumair
 2008/0010984 A1 1/2008 Arbel
 2011/0126703 A1 6/2011 Terasaki
 2017/0033639 A1 * 2/2017 Harris H02K 15/14
 2019/0226504 A1 7/2019 Richter
 2020/0300276 A1 9/2020 Tamura
 2020/0347847 A1 11/2020 Simon

OTHER PUBLICATIONS

Rajasthan Aluminium House Ltd., Aluminium Extruded Heat Sink, (site visited Mar. 25, 2021), Indiamart Website, URL: <<https://www.indiamart.com/proddetail/aluminium-extruded-heat-sink-18017473948.html>> (Year: 2021).*

Xinxiang Aluminum Blog, “Why are Aluminum Extruded Heat Sinks Preferred for Industrial Use?”, (posted Jul. 1, 2019), Xinxiaing Aluminum Website, URL: <<https://aluminum-extrusions.com/why-are-aluminum-extruded-heat-sinks-preferred-for-industrial-use/>> (Year: 2019).*

HAWE Hydraulik, Compact hydraulic power pack type KA2 and KAW2, (published Sep. 2017), HAWE Hydraulik SE, D 8010—KA, KAW—Sep. 2017—1.1, p. 1/70 (Year: 2017).

Design World Online, HAWE hydraulics compact power units, (site visited Dec. 11, 2020), Design World Online website, URL: <<https://www.designworldonline.com/hawe-hydraulics-compact-power-units/>> (Year: 2020).

Design Engineering, Allied Motion looks to OEMs with its Integrated Drive Electronics, Published Jul. 3, 2018), Design-Engineering.com, URL: <<https://www.design-engineering.com/products/electrohydraulic-pump-drive-motor/>> (Year: 2018).

* cited by examiner

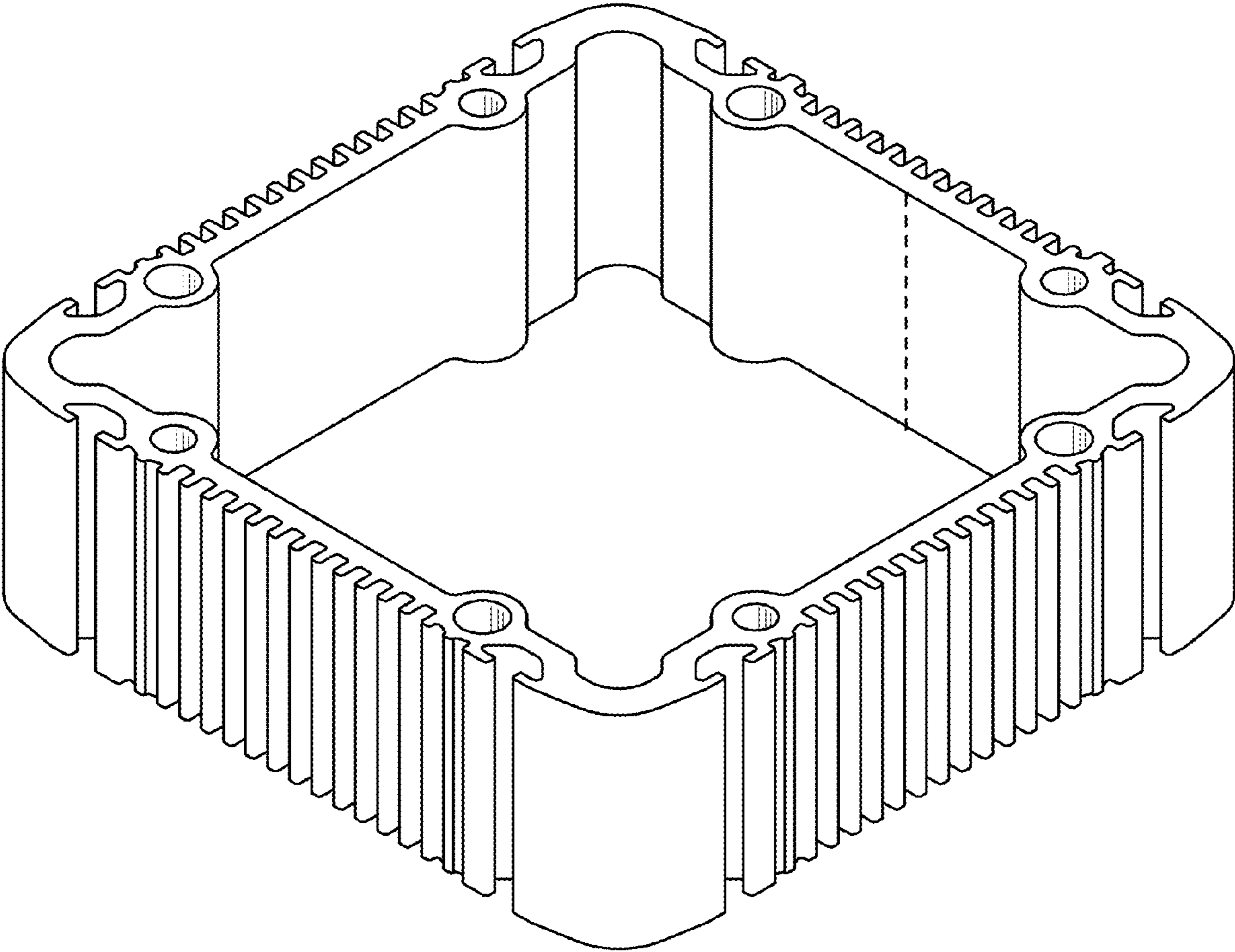

FIG. 1

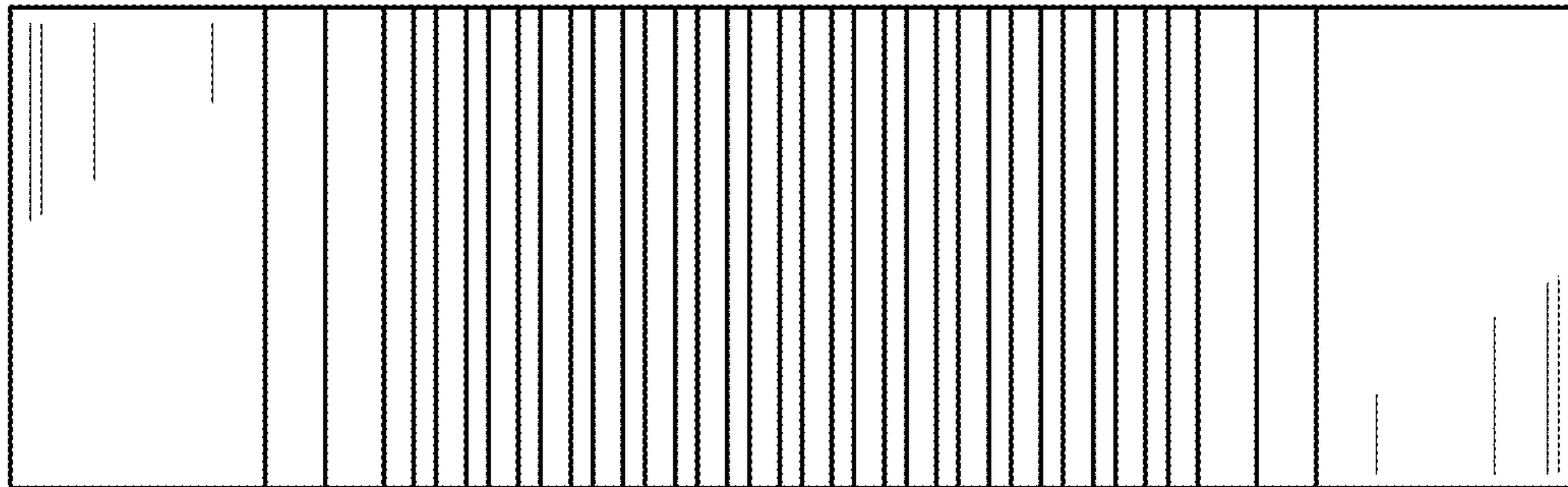

FIG. 2

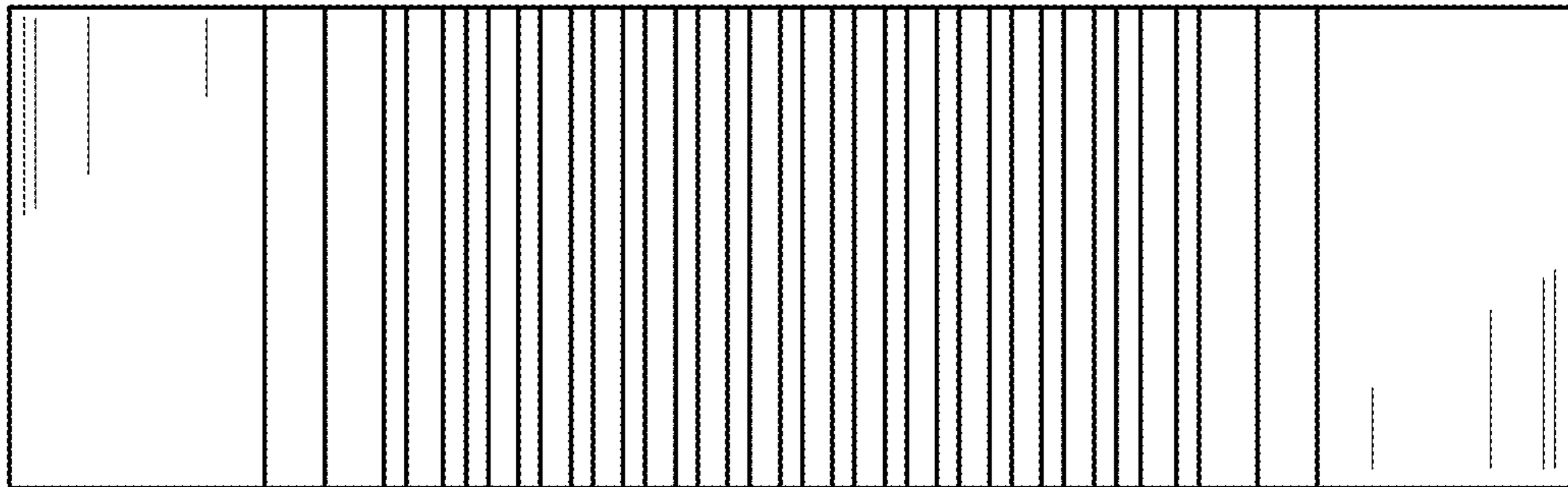

FIG. 3

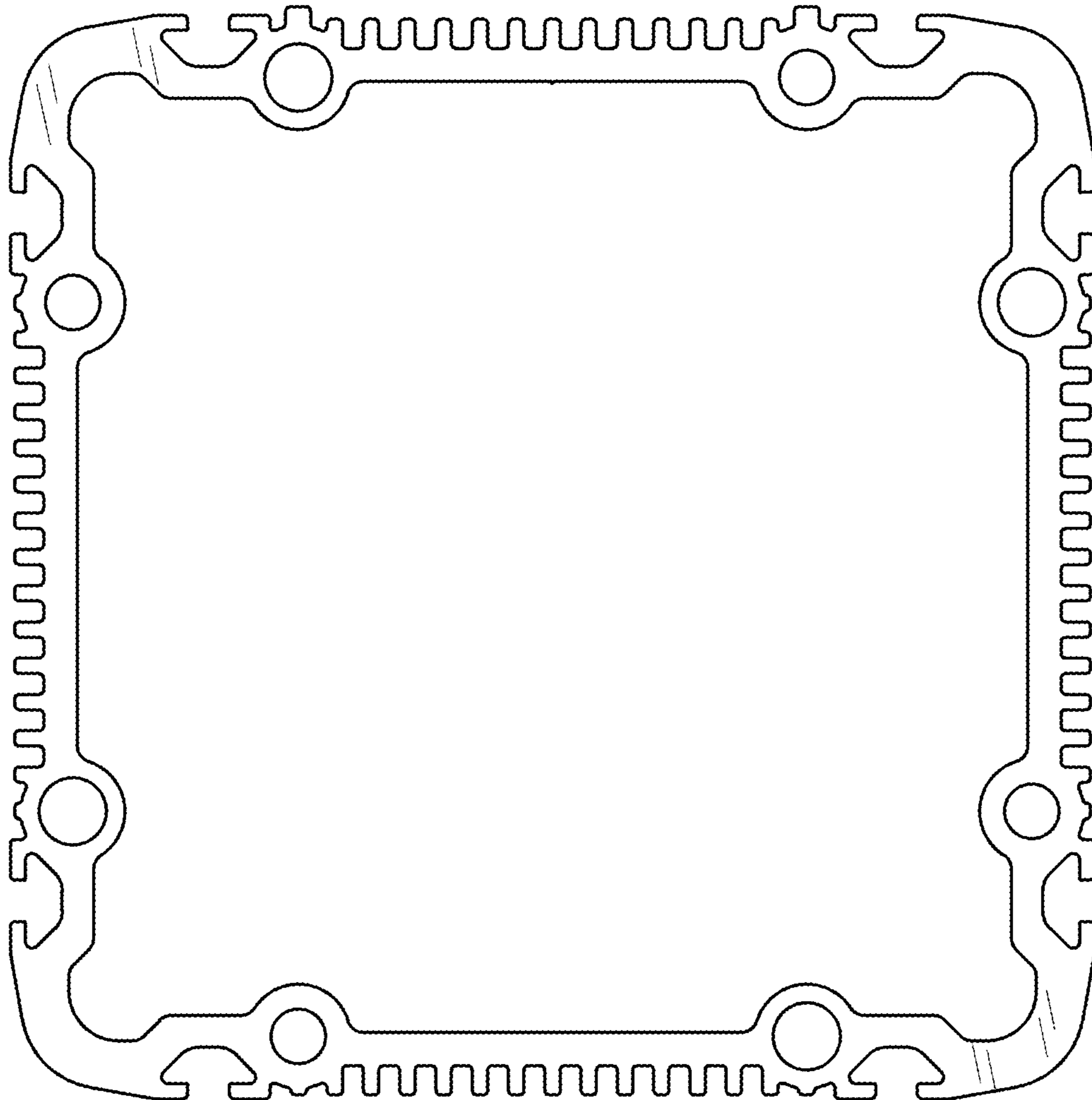

FIG. 4