



US00D924810S

(12) **United States Design Patent** (10) **Patent No.:** **US D924,810 S**  
**Rao et al.** (45) **Date of Patent:** **\*\* Jul. 13, 2021**

(54) **BUSBAR**

(71) Applicant: **Intel Corporation**, Santa Clara, CA  
(US)

(72) Inventors: **Samantha Rao**, Bangalore (IN);  
**Harish Jagadish**, Bangalore (IN);  
**Arvind S**, Bangalore (IN)

(73) Assignee: **Intel Corporation**, Santa Clara, CA  
(US)

(\*\*) Term: **15 Years**

(21) Appl. No.: **29/675,741**

(22) Filed: **Jan. 4, 2019**

(51) **LOC (13) Cl.** ..... **13-03**

(52) **U.S. Cl.**  
USPC ..... **D13/154**

(58) **Field of Classification Search**  
USPC ..... D13/118, 120, 133, 146, 149, 153, 154,  
D13/155, 173, 184, 199; D14/356, 432;  
D23/259, 262  
CPC ..... H01R 4/00; H01R 4/16; H01R 43/04  
See application file for complete search history.

(56) **References Cited**

**U.S. PATENT DOCUMENTS**

3,555,497	A *	1/1971	Wantanabe	.....	H01R 13/112 439/857
D324,204	S *	2/1992	Wright	.....	D13/154
D583,771	S *	12/2008	Lubanski	.....	D13/155
D606,024	S *	12/2009	Chiang	.....	D13/154
D794,574	S *	8/2017	Murphy	.....	D13/147
D815,042	S *	4/2018	Jenrich	.....	D13/133
10,026,529	B2 *	7/2018	Chiku	.....	H01C 1/04
D845,249	S *	4/2019	Sato	.....	D13/147
10,297,962	B1 *	5/2019	Costello	.....	H01R 25/145
D856,282	S *	8/2019	Pillsbury	.....	D13/133

D857,420	S *	8/2019	Schneider	.....	D6/545
2017/0179458	A1 *	6/2017	Sato	.....	H01M 2/1077
2019/0115704	A1 *	4/2019	Copperthite	.....	B23K 20/24

**OTHER PUBLICATIONS**

“Metal Plate Shunt Resistors”. Found online Jul. 13, 2020 at electronicsweekly.com. Reference dated Nov. 30, 2017. Retrieved from <https://www.electronicsweekly.com/news/products/passives/metal-plate-shunt-resistors-handle-high-currents-2017-11/>. (Year: 2017 ).\*

(Continued)

*Primary Examiner* — Kendra Leslie Hamilton  
*Assistant Examiner* — Amanda Christensen  
(74) *Attorney, Agent, or Firm* — Hanley, Flight and Zimmerman, LLC

(57) **CLAIM**

The ornamental design for a busbar, as shown and described.

**DESCRIPTION**

FIG. 1 is a right, top perspective view of a busbar, showing our new design.  
FIG. 2 is a front elevation view thereof.  
FIG. 3 is a rear elevation view thereof.  
FIG. 4 is a right side elevation view thereof.  
FIG. 5 is a left side elevation view thereof.  
FIG. 6 is a top plan view thereof.  
FIG. 7 is a bottom plan view thereof.  
FIG. 8 is a right, bottom perspective thereof; and,  
FIG. 9 is a right, top perspective view of the busbar of FIG. 1, shown in a condition for use and exploded for clarity of disclosure.  
The broken lines having dashes of equal length in the drawings depict portions of the busbar that form no part of the claimed design. The dash-dot-dash lines define the boundaries of the claim.

**1 Claim, 6 Drawing Sheets**

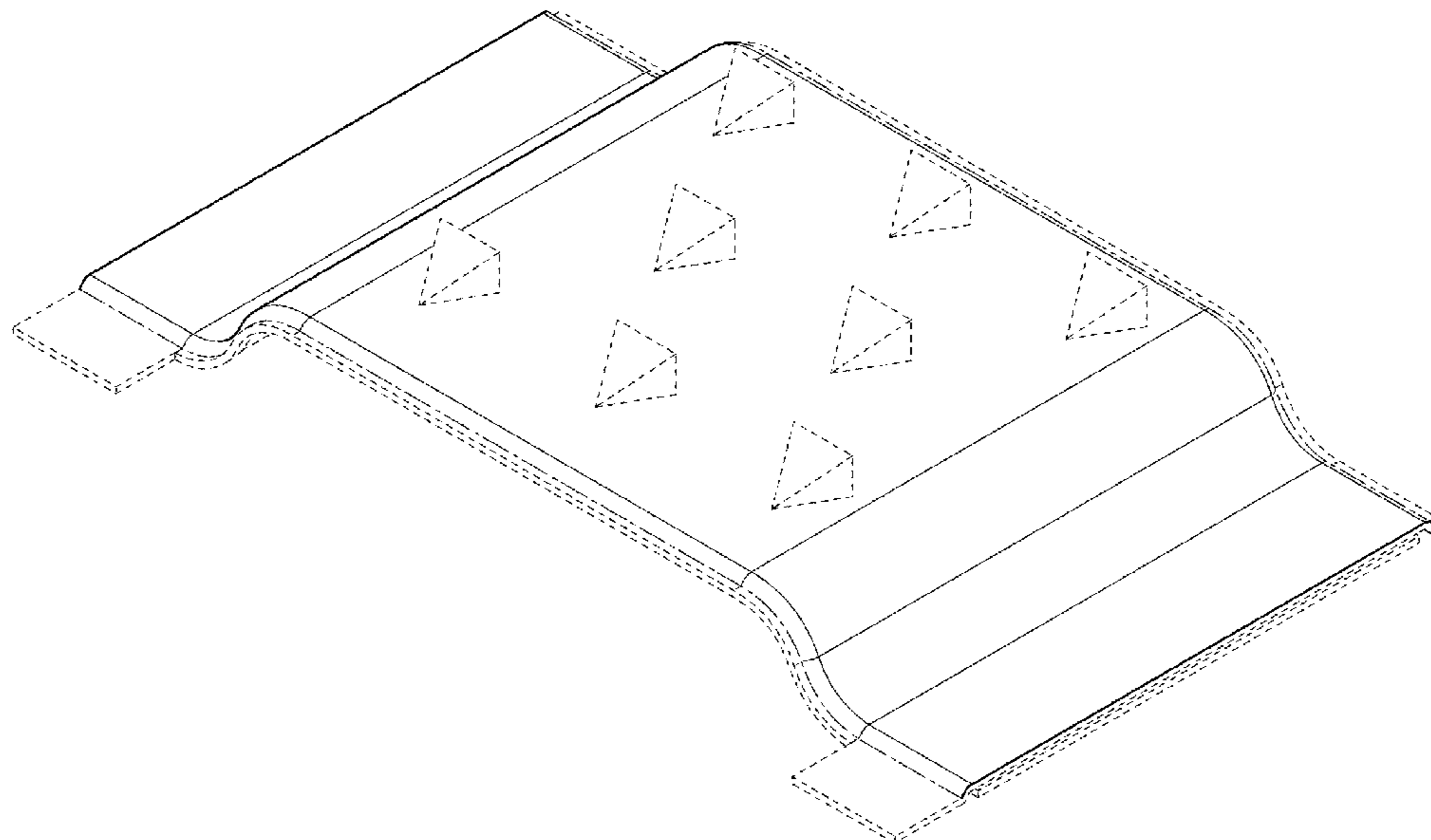

(56)

**References Cited**

OTHER PUBLICATIONS

“Power Shunt Current Sense Resistor”. Found online Jul. 13, 2020 at [powerelectronicstips.com](http://powerelectronicstips.com). Reference dated Jun. 1, 2018. Retrieved from <https://www.powerelectronicstips.com/power-shunt-current-sense-resistor-dissipates-12-w/>. (Year: 2017).\*

“Stierli-Bieger Busbar Bending Machine”. Found online Jul. 13, 2020 at [youtube.com](http://youtube.com). Reference dated Jan. 26, 2012. Retrieved from <https://www.youtube.com/watch?v=eGVaqKxeK3k>. (Year: 2012).\*

\* cited by examiner

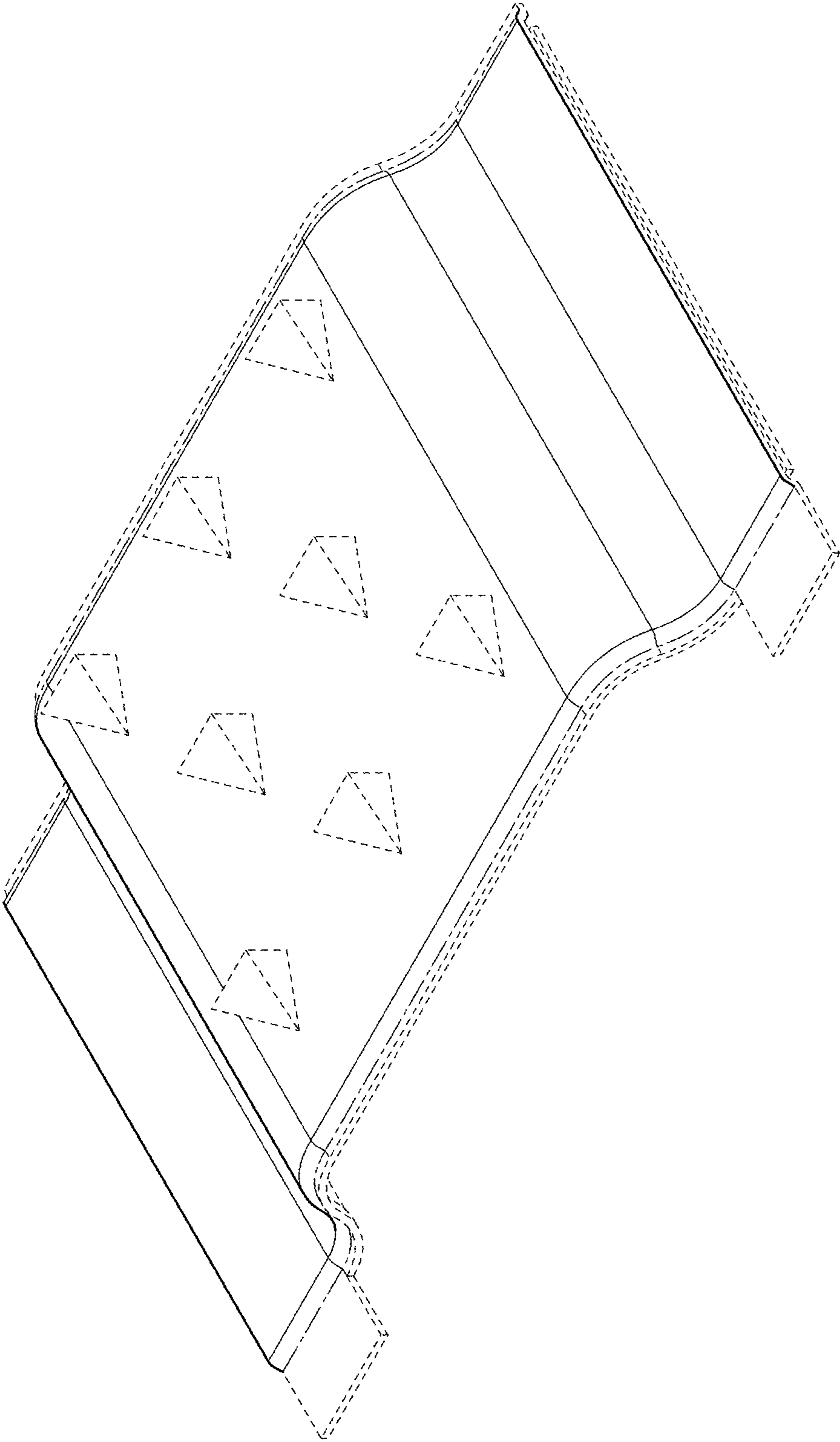

FIG. 1

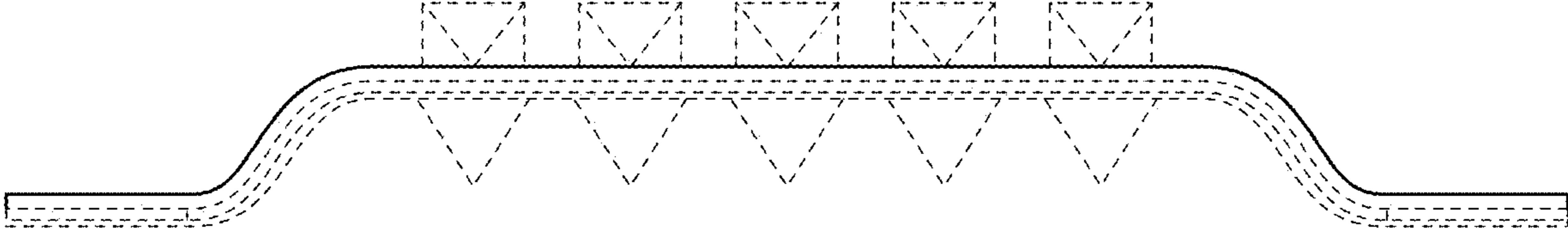

FIG. 2

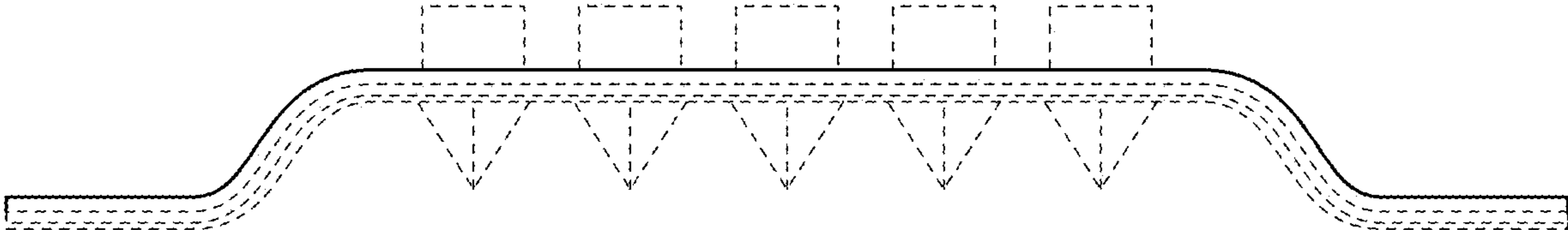

FIG. 3

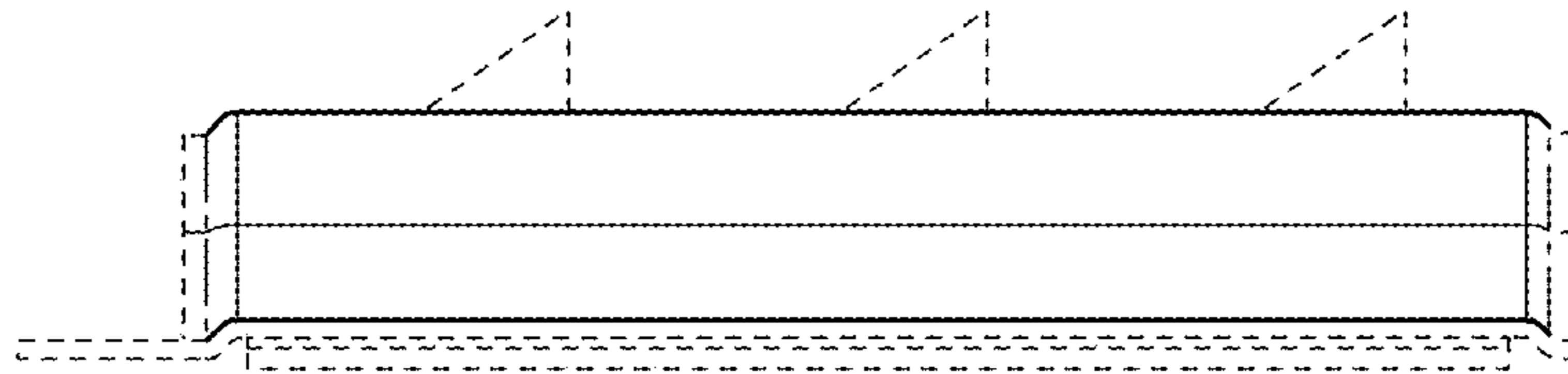

FIG. 4

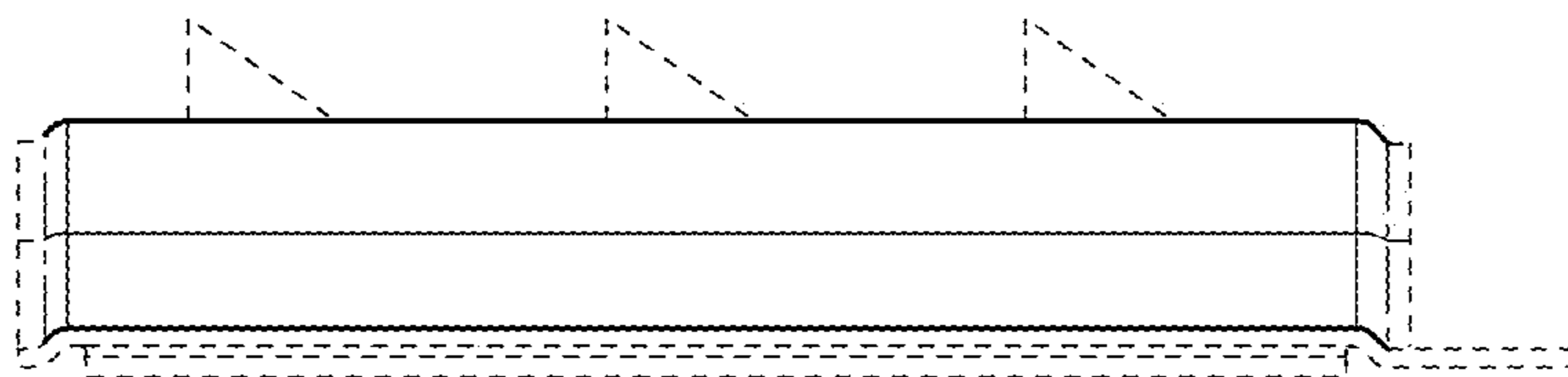

FIG. 5

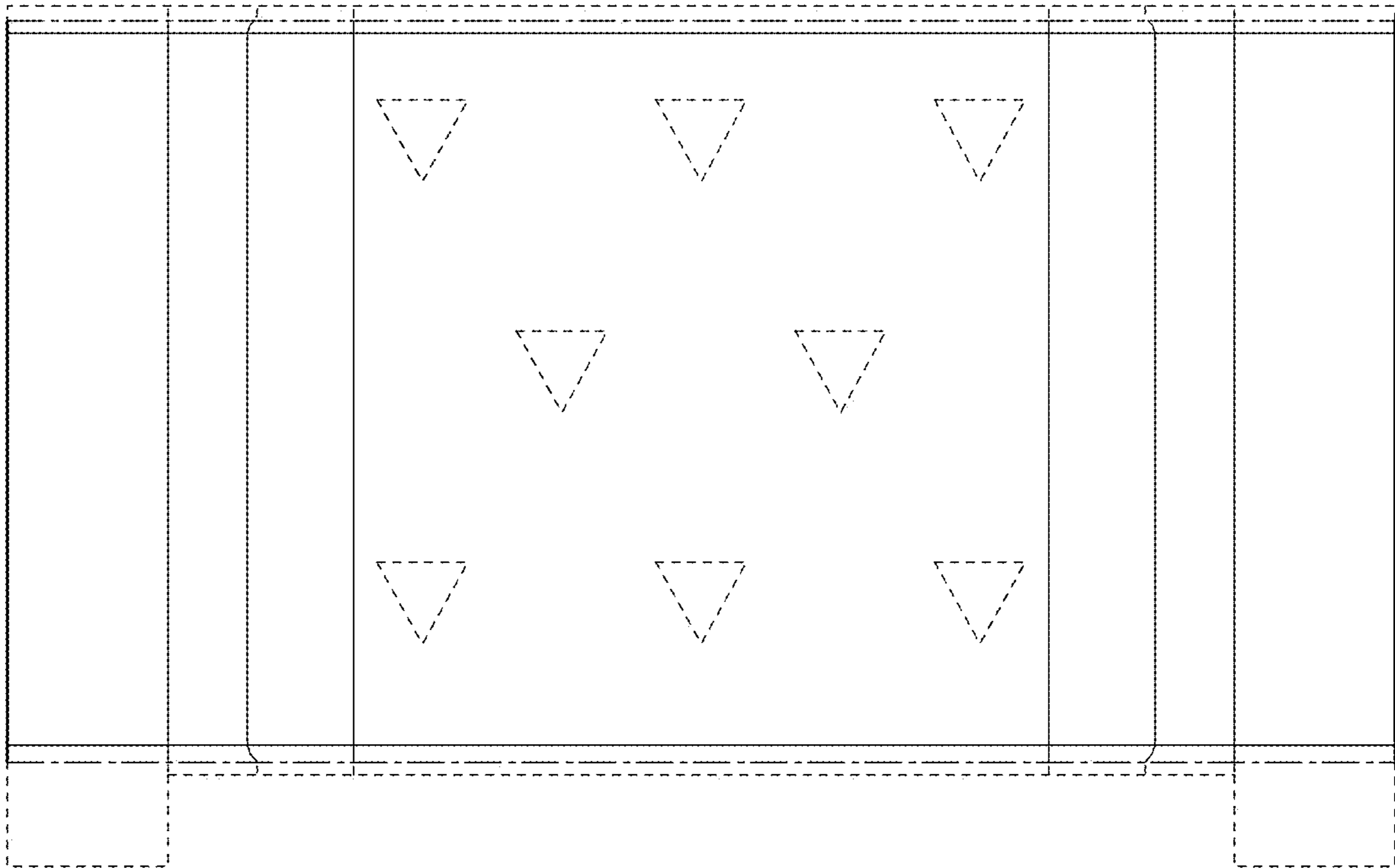

FIG. 6

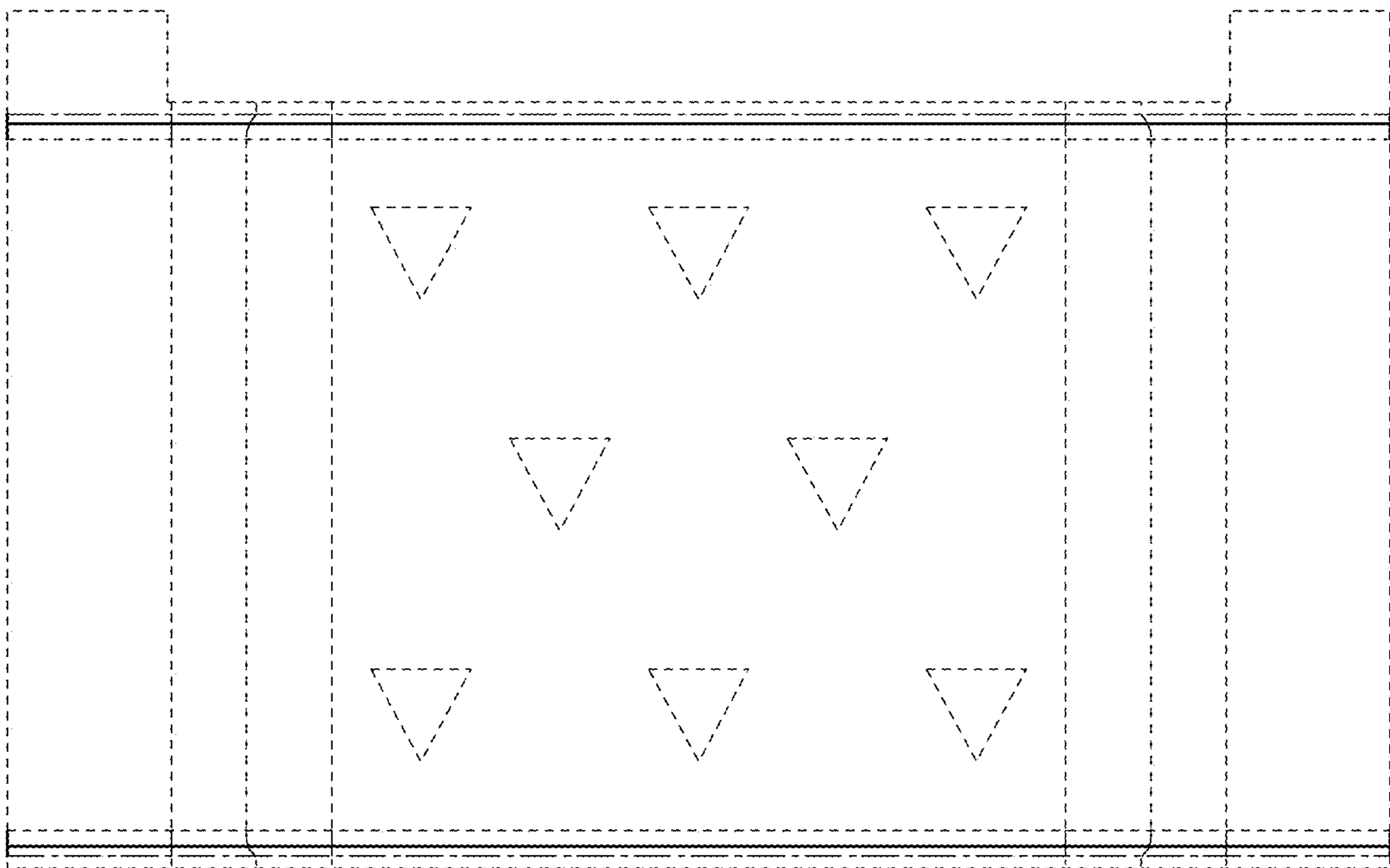

FIG. 7



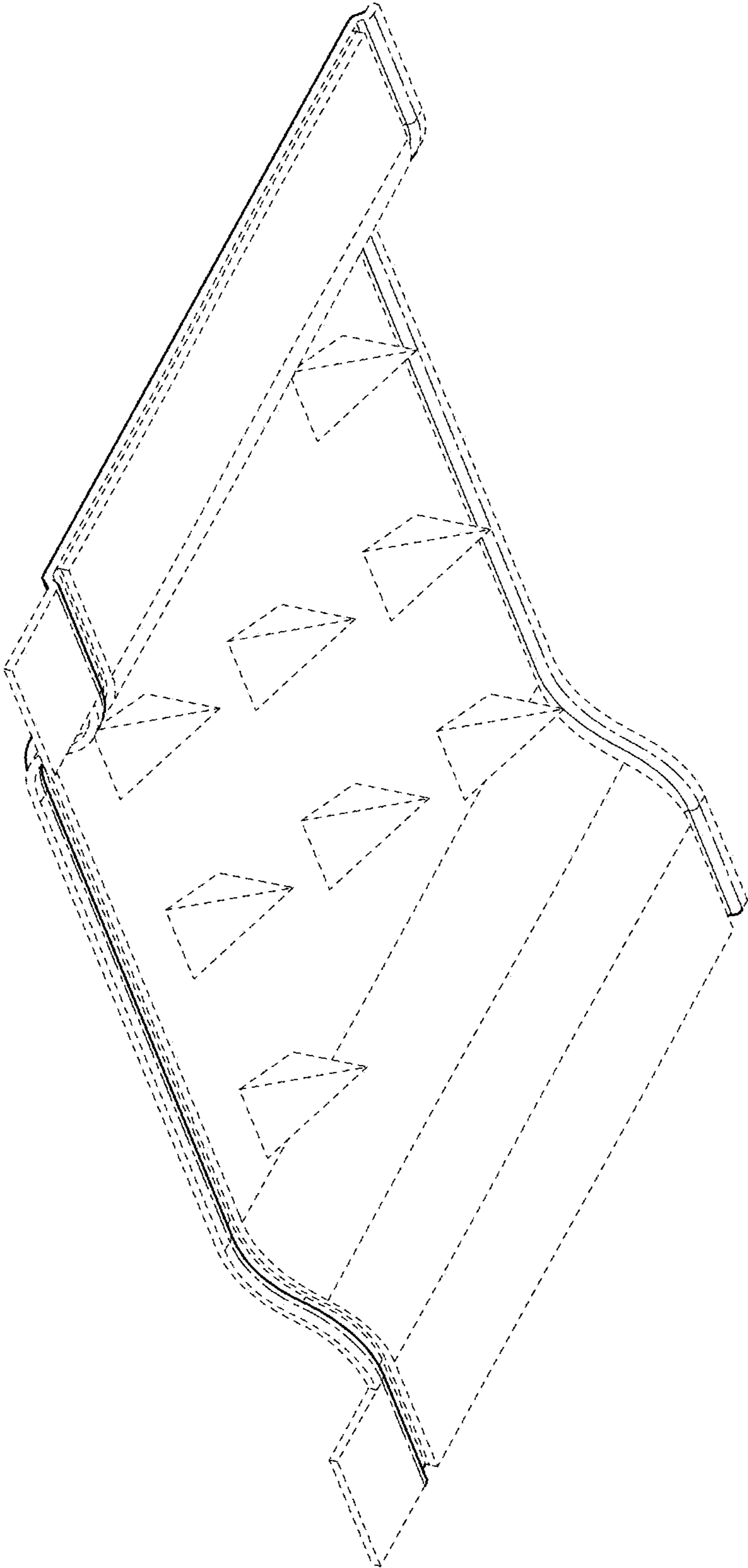

FIG. 8

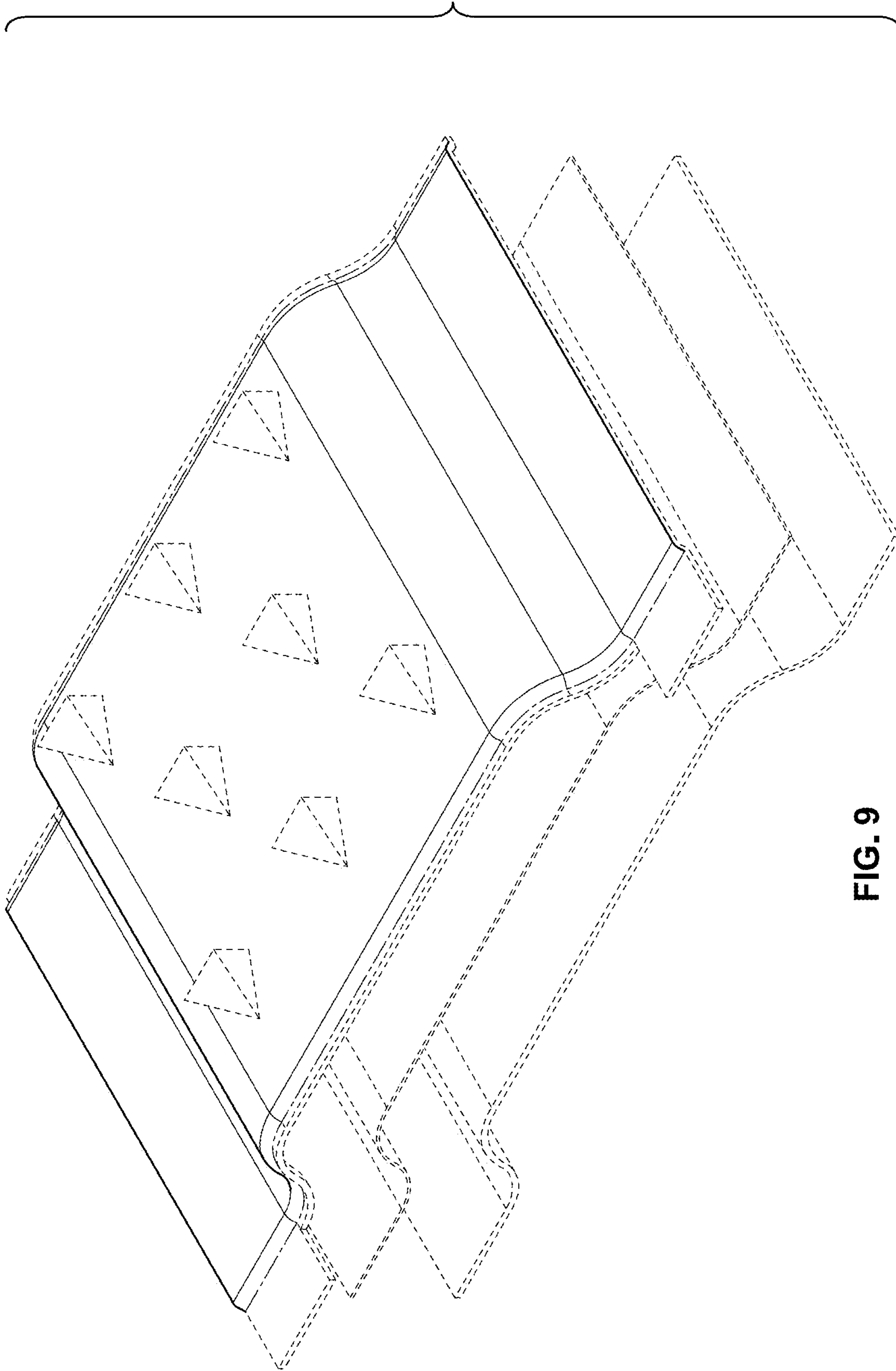

FIG. 9