



US00D924804S

(12) **United States Design Patent**
Hartmann et al.

(10) **Patent No.:** **US D924,804 S**

(45) **Date of Patent:** **** Jul. 13, 2021**

- (54) **BATTERY CONTAINER**
- (71) Applicant: **Latent Heat Solutions, LLC**, Golden, CO (US)
- (72) Inventors: **Mark Hartmann**, Boulder, CO (US);
Joseph Kelly, Arvada, CO (US)
- (73) Assignee: **Latent Heat Solutions, LLC**, Golden, CO (US)
- (**) Term: **15 Years**
- (21) Appl. No.: **29/762,137**
- (22) Filed: **Dec. 15, 2020**

- D274,789 S * 7/1984 Brown D9/758
- D274,885 S * 7/1984 Joice D9/758
- 4,487,316 A * 12/1984 Calhoun A45D 6/00
206/443
- D287,633 S * 1/1987 Hollar D24/230
- D325,477 S * 4/1992 Poulsen D13/119
- D349,814 S * 8/1994 Crisp D3/319
- D364,929 S * 12/1995 Bigler D24/230
- D380,611 S * 7/1997 Mancusi D13/119
- D420,743 S * 2/2000 Monks D24/224
- D461,554 S * 8/2002 Lafond D24/227
- D515,941 S * 2/2006 Hamblin D24/230
- D515,943 S * 2/2006 Hamblin D24/230
- D596,594 S * 7/2009 Kressy D13/184
- D596,758 S * 7/2009 Constable D24/230

(Continued)

Related U.S. Application Data

- (62) Division of application No. 29/619,763, filed on Oct. 2, 2017, now Pat. No. Des. 911,961.
- (51) **LOC (13) Cl.** **13-02**
- (52) **U.S. Cl.**
USPC **D13/119**
- (58) **Field of Classification Search**
USPC D13/110, 118, 119, 122, 123,
D13/137.1–137.4, 138.1–138.2,
D13/139.1–139.8, 160, 178, 184, 199,
D13/152, 156; D3/262; D24/227, 229,
D24/230
CPC H01R 13/6675; H01R 13/10; H01R 13/44;
H01R 13/66; H01R 13/652; H01R
31/065; H01R 31/00; H01R 9/00; H01R
11/00; H01R 25/00; H01R 25/006; H01H
2207/00; H01H 2207/022
See application file for complete search history.

(56) **References Cited**

U.S. PATENT DOCUMENTS

- 2,926,809 A * 3/1960 Studler B65D 81/133
217/30
- D256,081 S * 7/1980 Patterson D3/311

OTHER PUBLICATIONS

Amazon.com: Thermo Scientific Block Heater for Compact Dry Bath/Block Heater . . . Date First Available of Sep. 21, 2018. Retrieved from the internet at <<https://www.amazon.com/Thermo-Scientific-Block-Heater-Compact/dp/B07DM3CVSZ/>>, Mar. 8, 2021. 1 page. (Year: 2018).*

Primary Examiner — Christy Nemeth

(74) *Attorney, Agent, or Firm* — FisherBroyles, LLP;
Susan M. Oiler

(57) **CLAIM**

The ornamental design for a battery container, as shown and described.

DESCRIPTION

FIG. 1 is a perspective view of a battery container;
FIG. 2 is a front view thereof;
FIG. 3 is a rear view thereof;
FIG. 4 is a right side view thereof;
FIG. 5 is a left side view thereof;
FIG. 6 is a top view thereof; and,
FIG. 7 is a bottom view thereof.

1 Claim, 6 Drawing Sheets

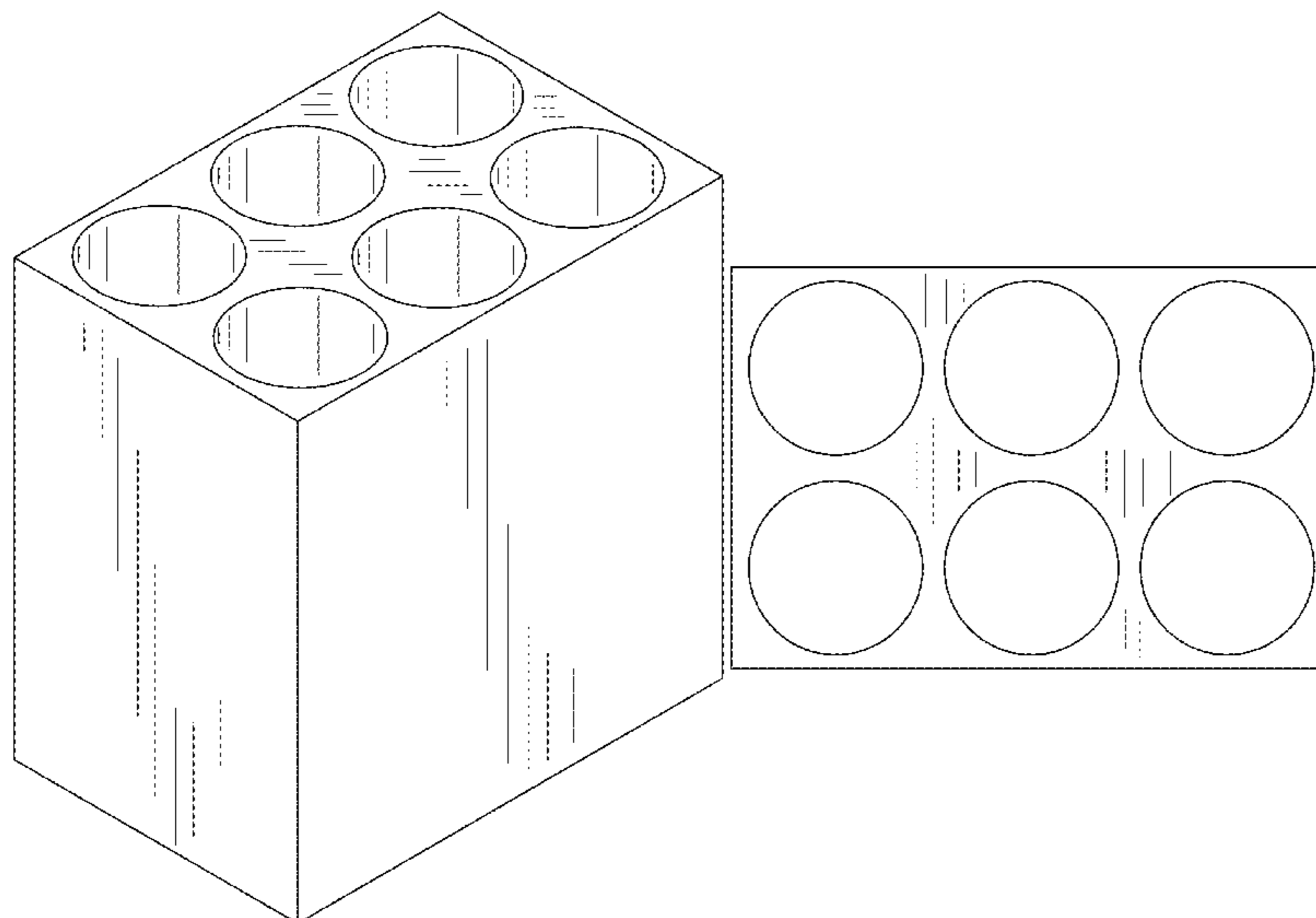

(56)

References Cited

U.S. PATENT DOCUMENTS

D598,566 S *	8/2009	Allaer	D24/230	D840,053 S *	2/2019	Kamees	D24/230
D622,860 S *	8/2010	Karpiloff	D24/230	D844,806 S *	4/2019	Johns	D24/227
D625,431 S *	10/2010	Karpiloff	D24/230	D848,735 S *	5/2019	Sibley	D3/262
D628,450 S *	12/2010	Kulzer	D7/701	D849,962 S *	5/2019	Curry	D24/227
D629,121 S *	12/2010	Karpiloff	D24/230	D854,707 S *	7/2019	Jakobsen	D24/230
D629,122 S *	12/2010	Karpiloff	D24/230	D863,591 S *	10/2019	Manich	D24/227
D632,404 S *	2/2011	Karpiloff	D24/230	D867,614 S *	11/2019	Jones	D24/227
D639,447 S *	6/2011	Karpiloff	D24/230	D868,289 S *	11/2019	Muller	D24/230
D695,078 S *	12/2013	Hertaus	D7/600.1	D868,996 S *	12/2019	Muller	D24/230
D697,227 S *	1/2014	Motadel	D24/227	D873,170 S *	1/2020	Cooley	A01G 9/0295 D11/155
D699,371 S *	2/2014	Williams	D24/230	D875,272 S *	2/2020	Muller	D24/224
D729,550 S *	5/2015	Williams	D6/675	D882,818 S *	4/2020	Leimkuehler	D24/227
D739,680 S *	9/2015	Smeja	D7/600.1	D887,890 S *	6/2020	Liu	D11/155
D768,873 S *	10/2016	Stedman	D24/227	D892,755 S *	8/2020	Dubois	D13/199
D780,522 S *	3/2017	Howell	D7/605	D893,440 S *	8/2020	Krivonak	D13/184
D787,702 S *	5/2017	Kawamura	D24/227	D893,747 S *	8/2020	Hautamaki	D24/229
D788,038 S *	5/2017	Tateno	D13/129	D894,424 S *	8/2020	Livingston	D24/227
D788,706 S *	6/2017	Tateno	D13/129	D902,433 S *	11/2020	Livingston	D24/227
D791,717 S *	7/2017	Uusitalo	D13/160	D902,434 S *	11/2020	Livingston	D24/227
D793,799 S *	8/2017	Dunne	D7/357	D903,592 S *	12/2020	Hoshida	D13/118
D804,052 S *	11/2017	Dadachanji	D24/230	D903,593 S *	12/2020	Hoshida	D13/118
D808,540 S *	1/2018	Johns	D24/227	D904,304 S *	12/2020	Hoshida	D13/118
D809,575 S *	2/2018	Ishizaki	D15/136	D911,285 S *	2/2021	Manuel	D13/119
D825,775 S *	8/2018	Muller	D24/230	D911,961 S *	3/2021	Hartmann	D13/119
D826,425 S *	8/2018	Muller	D24/230	2004/0031835 A1 *	2/2004	McLeod	F42B 39/26 224/544
D826,426 S *	8/2018	Muller	D24/230	2007/0020512 A1 *	1/2007	Wakuda	B65D 71/70 429/99
D833,031 S *	11/2018	Curry	D24/227	2019/0372069 A1 *	12/2019	Lee	H01M 10/0422
D833,489 S *	11/2018	Ishizaki	D15/136	2020/0014006 A1 *	1/2020	Oliveira	H01M 10/653
D834,624 S *	11/2018	Ishizaki	D15/136	2020/0220122 A1 *	7/2020	Haertel	H01M 50/20
D834,722 S *	11/2018	Sugie	D24/227					
D839,326 S *	1/2019	Ishizaki	D15/136					

* cited by examiner

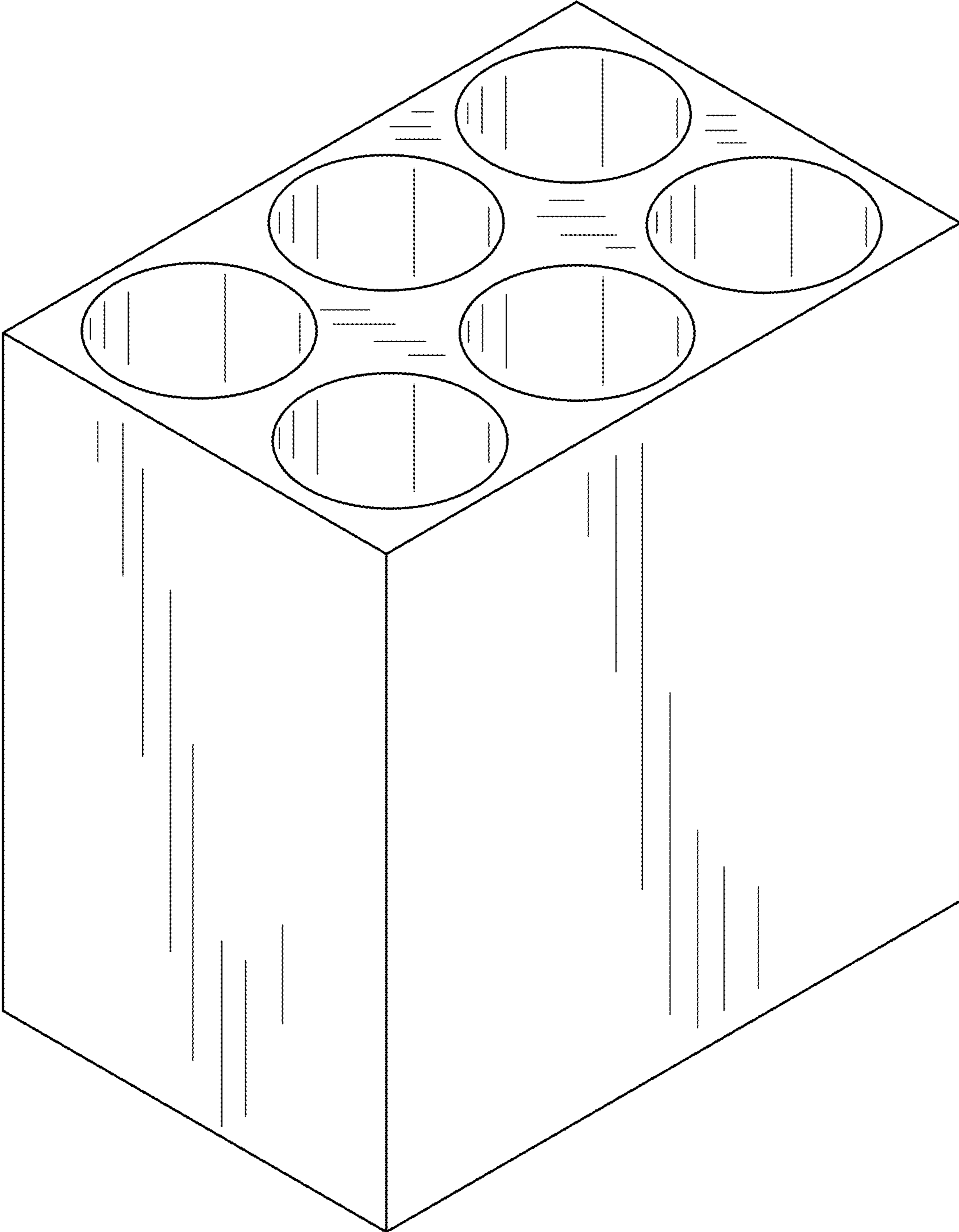

FIG. 1

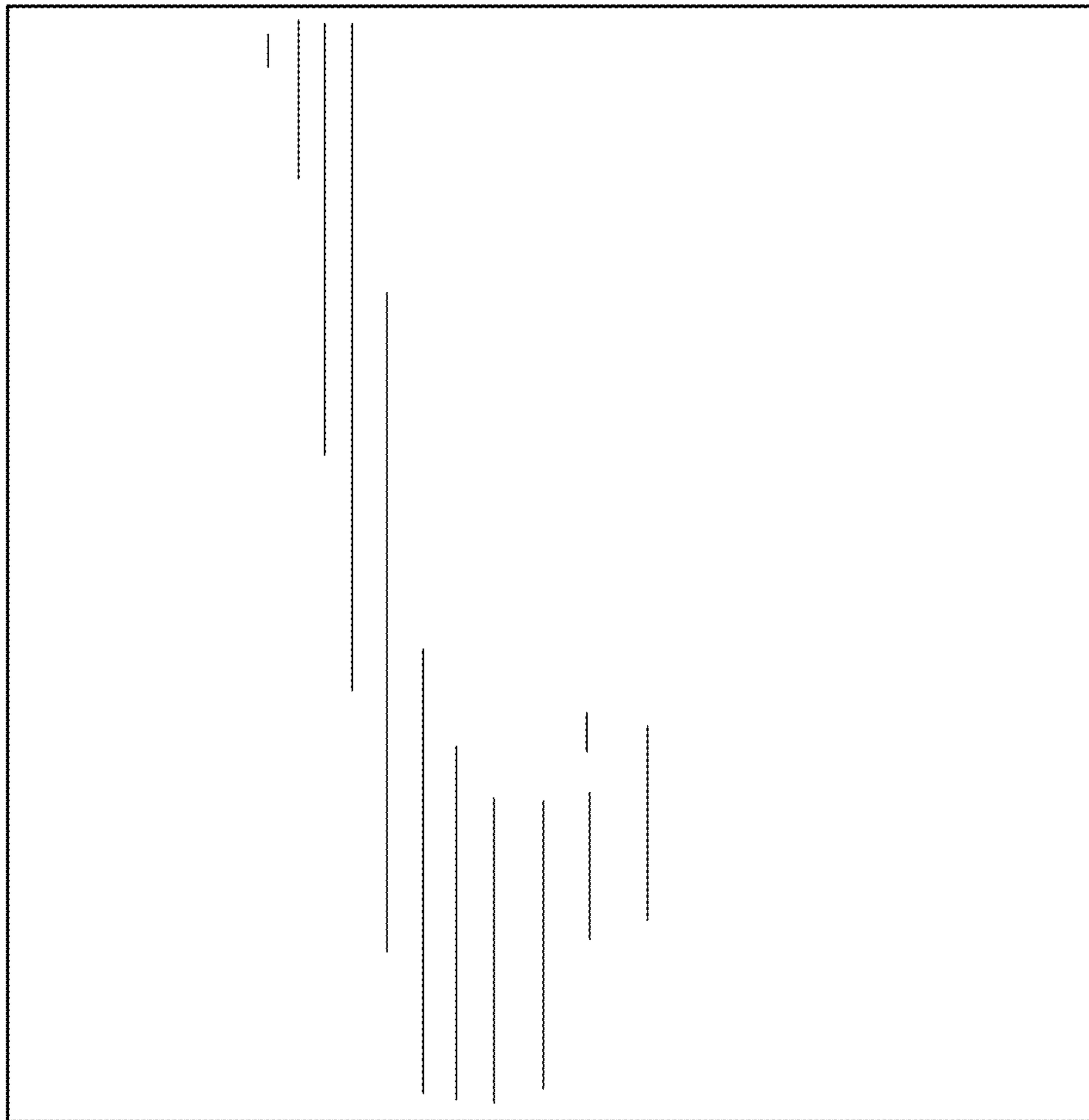

FIG. 2

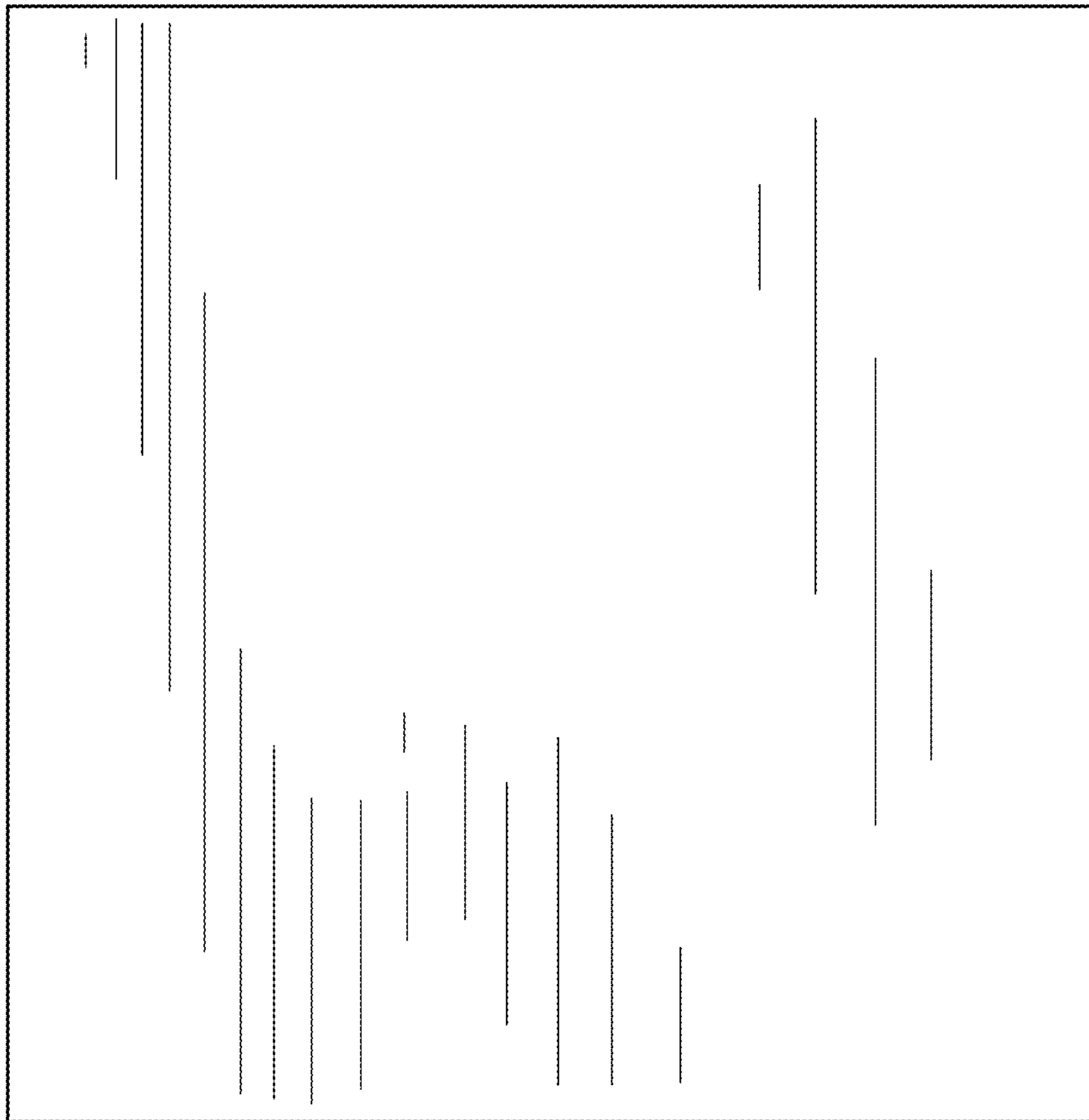

FIG. 3

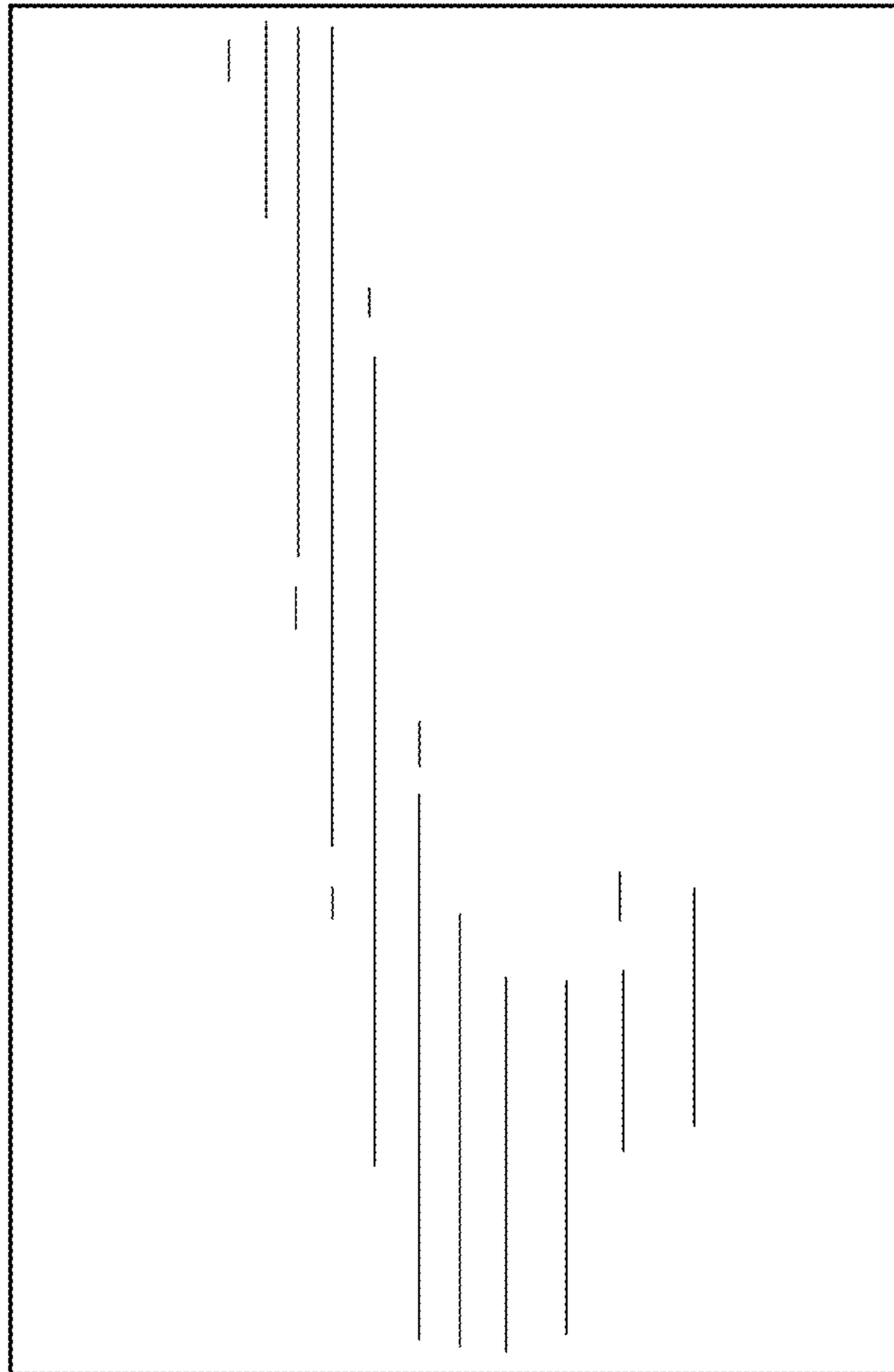

FIG. 4

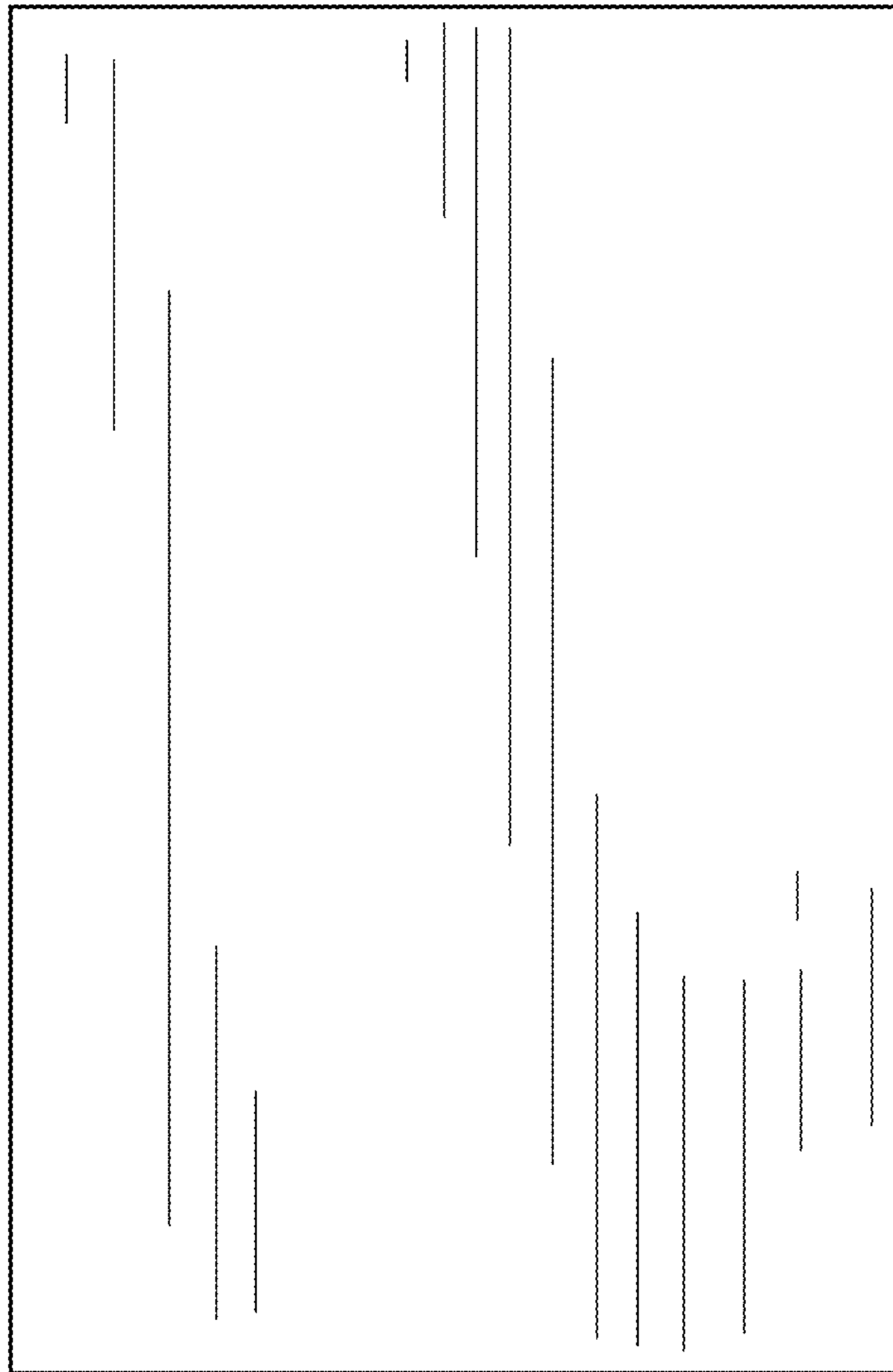

FIG. 5

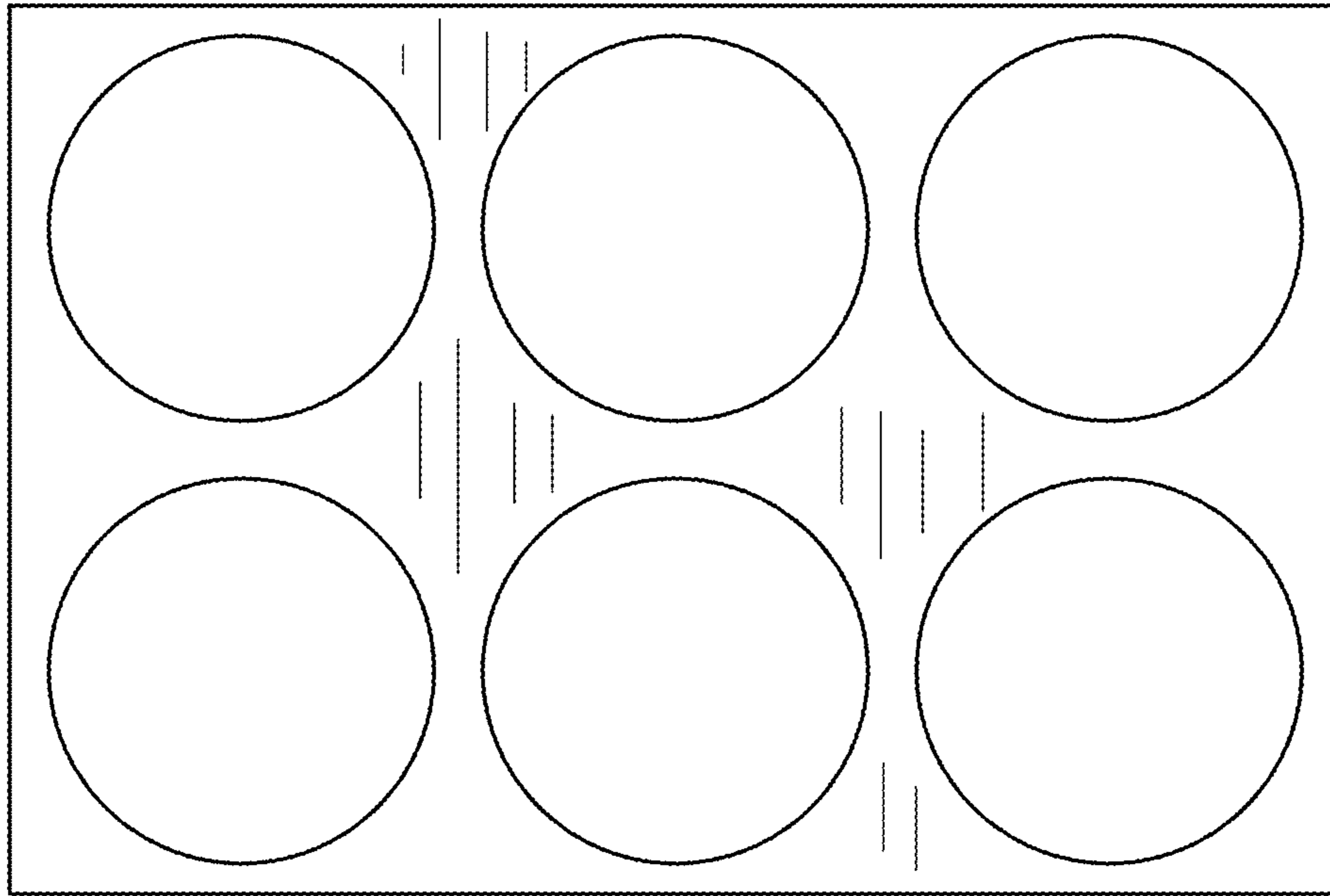

FIG. 6

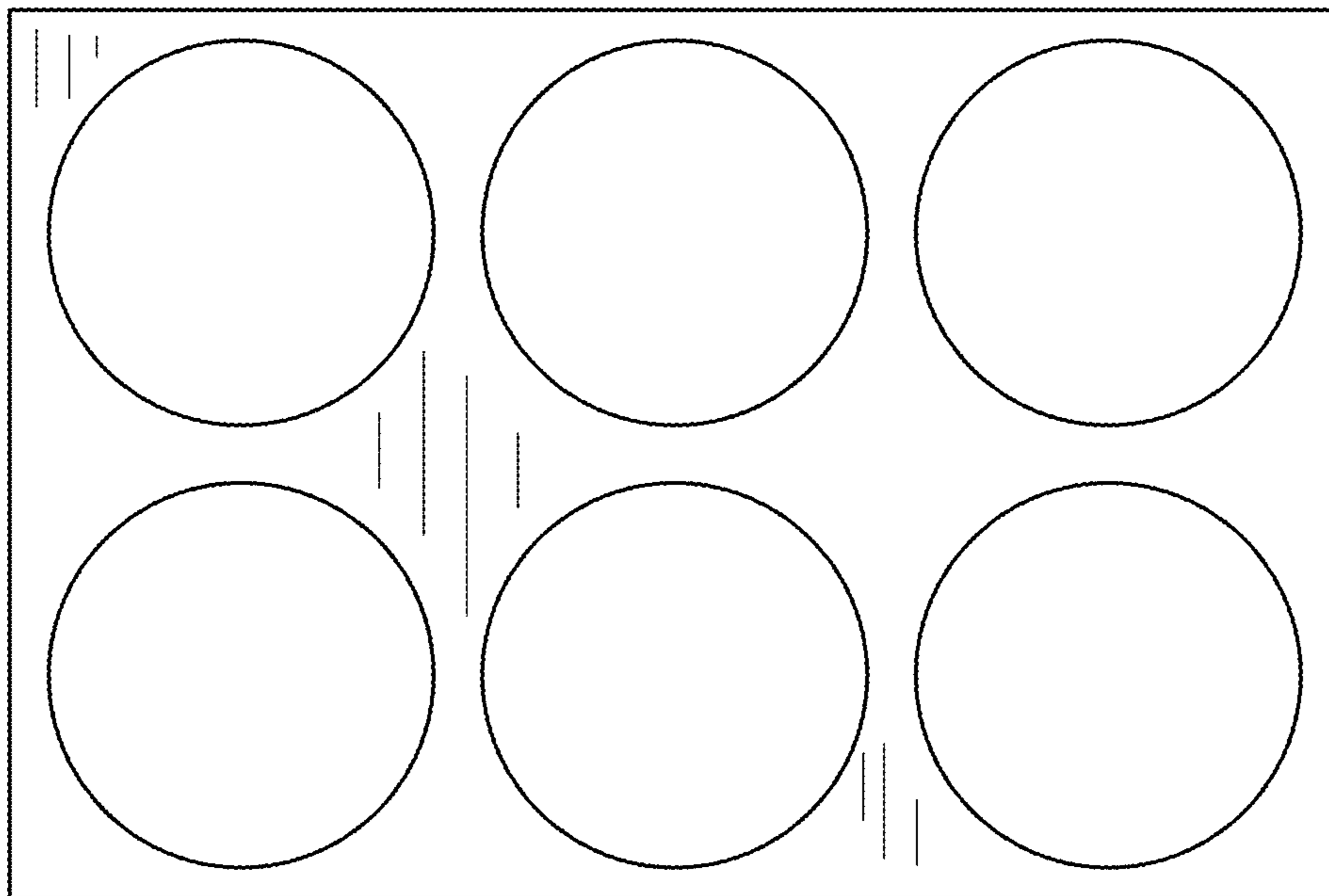

FIG. 7