



US00D923715S

(12) **United States Design Patent**
Wang et al.

(10) **Patent No.:** **US D923,715 S**
(45) **Date of Patent:** **** Jun. 29, 2021**

(54) **ELECTRIC SCOOTER**

(71) Applicant: **Freeman IT Limited**, Shenzhen (CN)

(72) Inventors: **Jing Wang**, Shenzhen (CN); **Haibo Liu**, Shenzhen (CN)

(73) Assignee: **Freeman IT Limited**, Shenzhen (CN)

(**) Term: **15 Years**

(21) Appl. No.: **29/715,358**

(22) Filed: **Dec. 2, 2019**

(30) **Foreign Application Priority Data**

Sep. 2, 2019 (CN) 201930480370.3

(51) **LOC (13) Cl.** **21-01**

(52) **U.S. Cl.**
USPC **D21/423**

(58) **Field of Classification Search**
USPC D21/419, 421, 423, 432, 435, 760, 763,
D21/765, 771; D12/1, 110

CPC B62K 3/002; B62K 9/00; B62K 2202/00;
B62K 15/00; B62K 2015/001; B62K
2015/003; B60Y 2200/126

See application file for complete search history.

(56) **References Cited**

U.S. PATENT DOCUMENTS

D686,674 S * 7/2013 Hadley D21/423
D727,833 S * 4/2015 Talios D12/423
D777,844 S * 1/2017 O Connell D21/423

D839,358 S * 1/2019 Cao D21/423
D877,257 S * 3/2020 Cao D21/423
D877,258 S * 3/2020 Cao D21/423
D903,002 S * 11/2020 Wang D21/423
2020/0283086 A1* 9/2020 Ulmen B62M 6/65

* cited by examiner

Primary Examiner — Cynthia M. Chin

(74) *Attorney, Agent, or Firm* — Westbridge IP LLC

(57) **CLAIM**

The ornamental design for an electric scooter, as shown and described.

DESCRIPTION

FIG. 1 is a top, front and left side perspective view of an electric scooter showing our new design;
FIG. 2 is a top, front and right side perspective view thereof;
FIG. 3 is a front elevational view thereof;
FIG. 4 is a rear elevational view thereof;
FIG. 5 is a left side elevational view thereof;
FIG. 6 is a right side elevational view thereof;
FIG. 7 is a top plan view thereof;
FIG. 8 is a bottom plan view thereof;
FIG. 9 is an enlarged view of a portion of FIG. 1;
FIG. 10 is an enlarged view of another portion of FIG. 1; and,
FIG. 11 is an enlarged view of a portion of FIG. 2.
The broken lines in the drawings illustrate portions of the electric scooter which form no part of the claimed design. The dash-dot broken lines represent the boundaries of the enlarged partial views of FIGS. 9-11 and form no part of the claimed design.

1 Claim, 11 Drawing Sheets

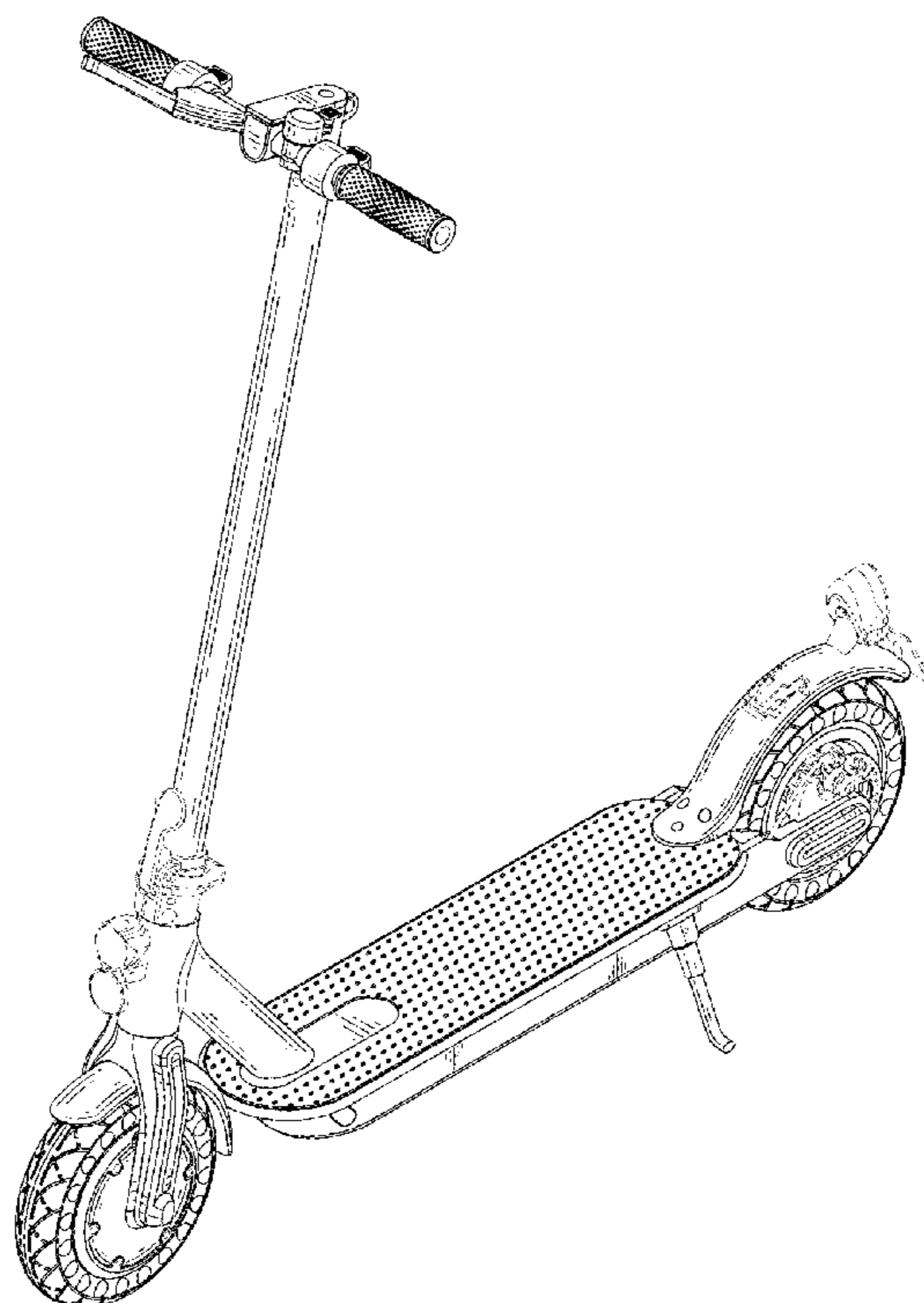

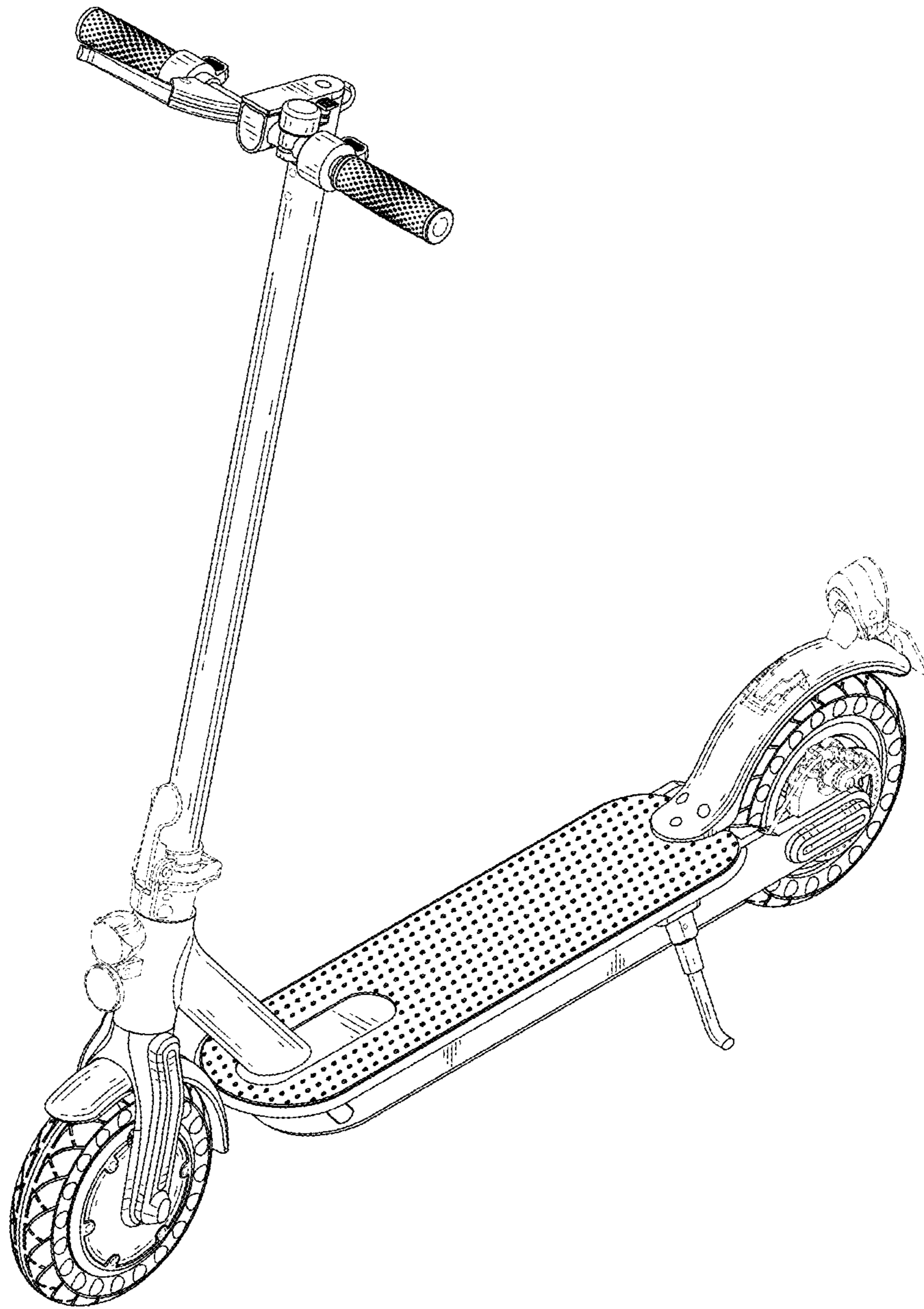

FIG. 1

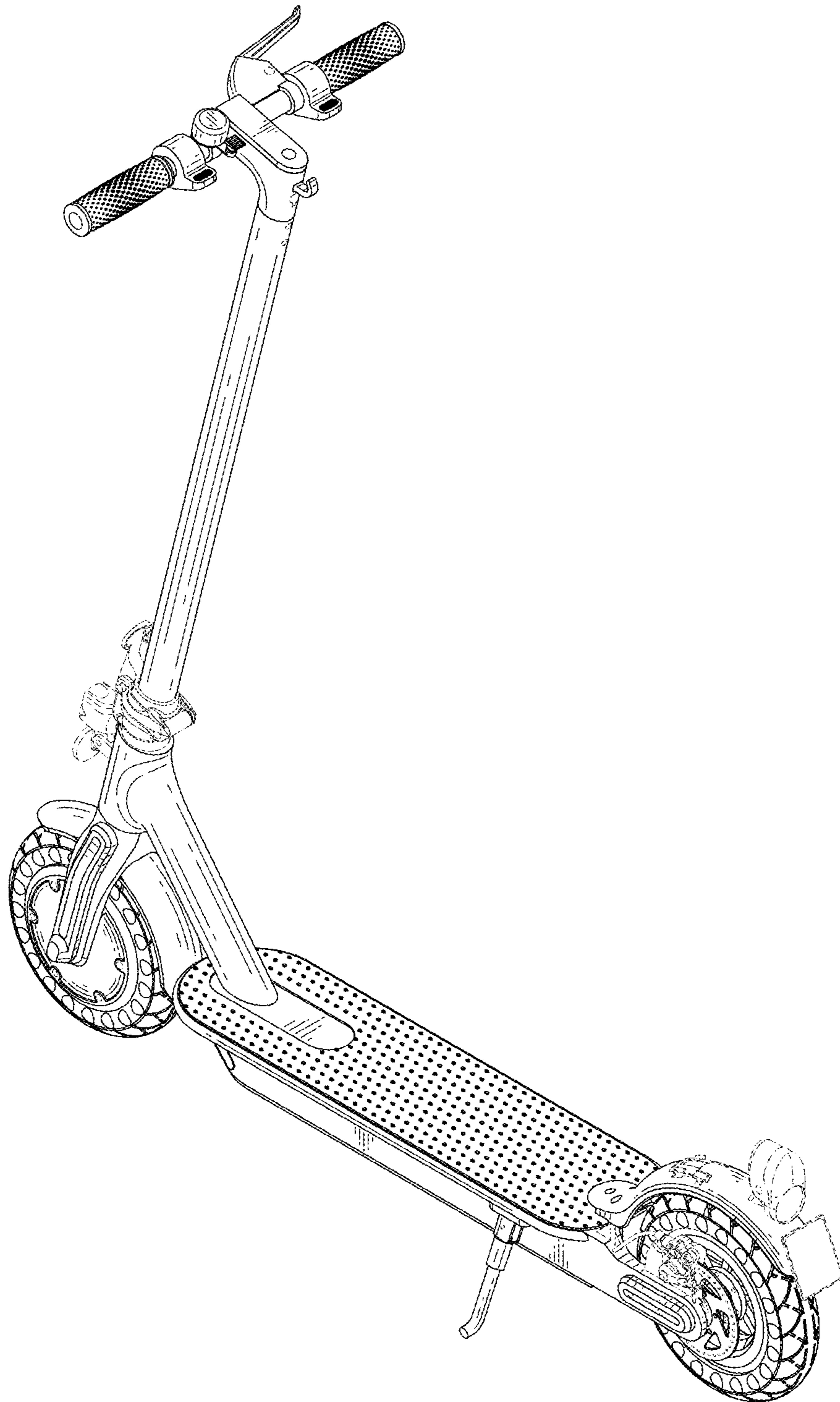

FIG. 2

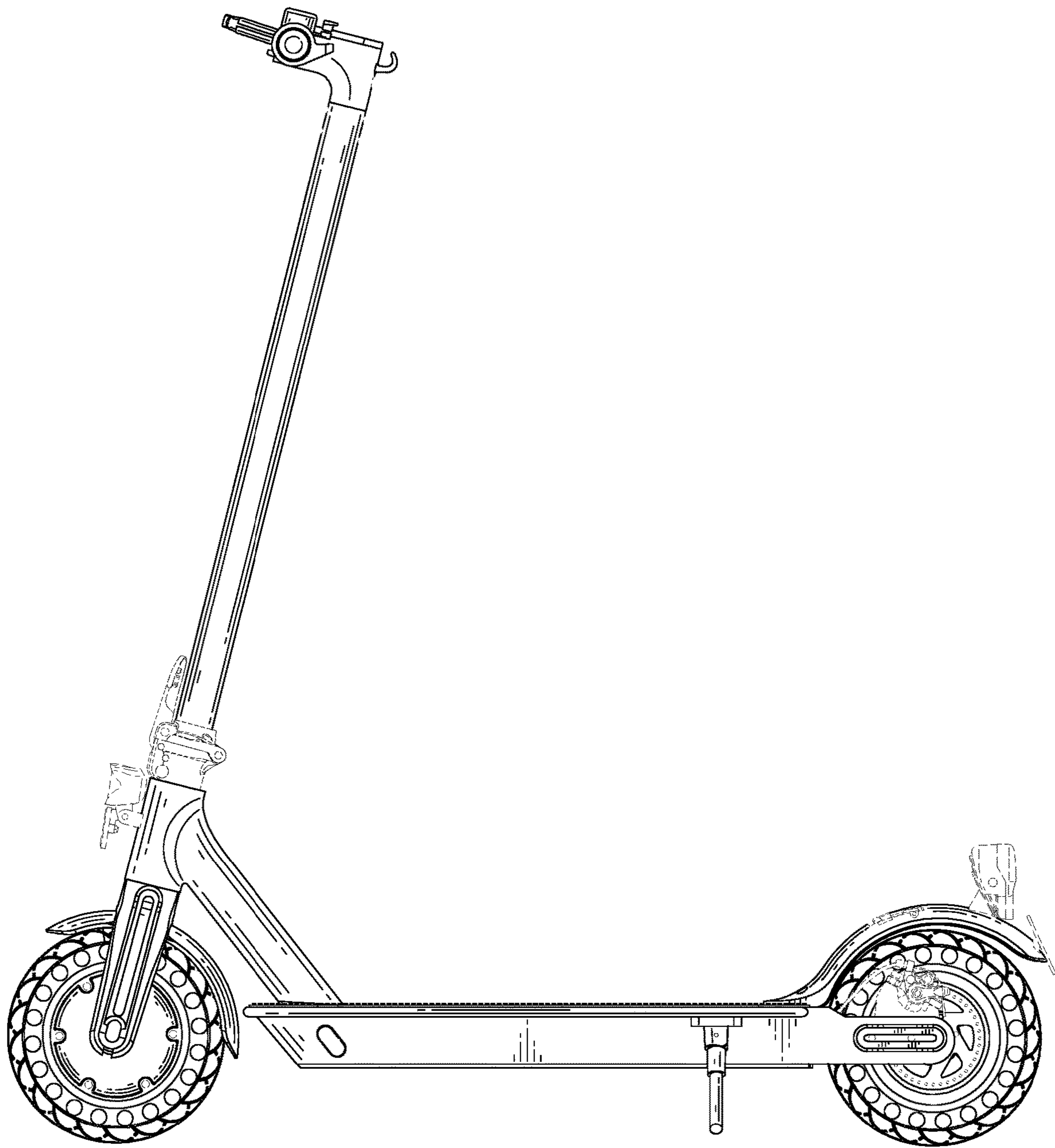

FIG. 3

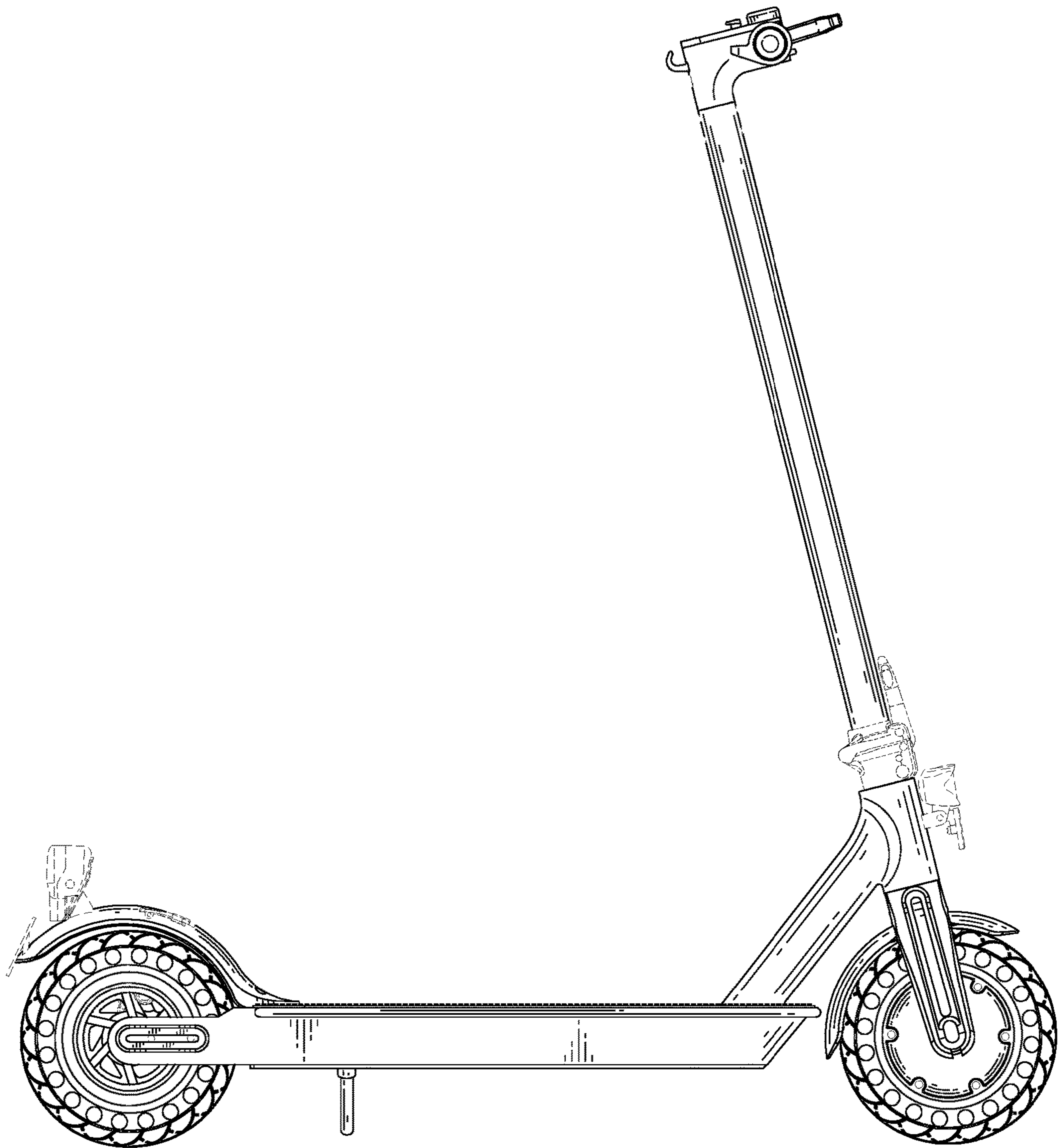

FIG. 4

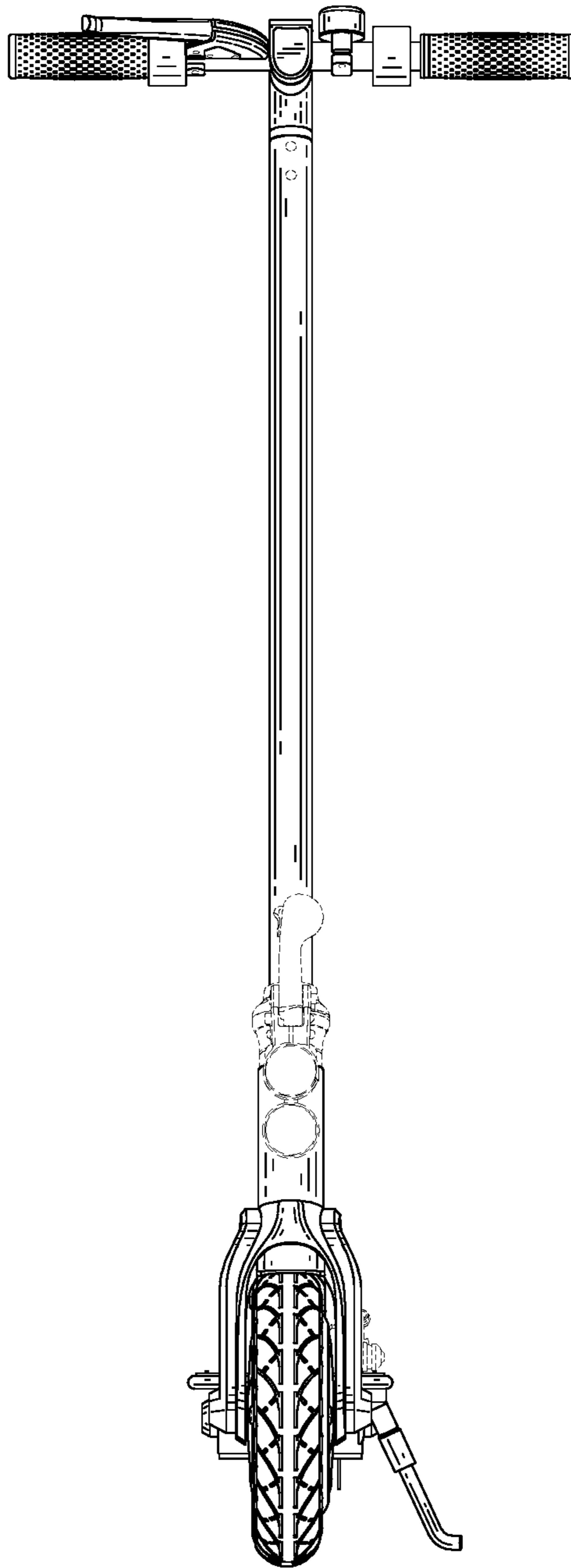

FIG. 5

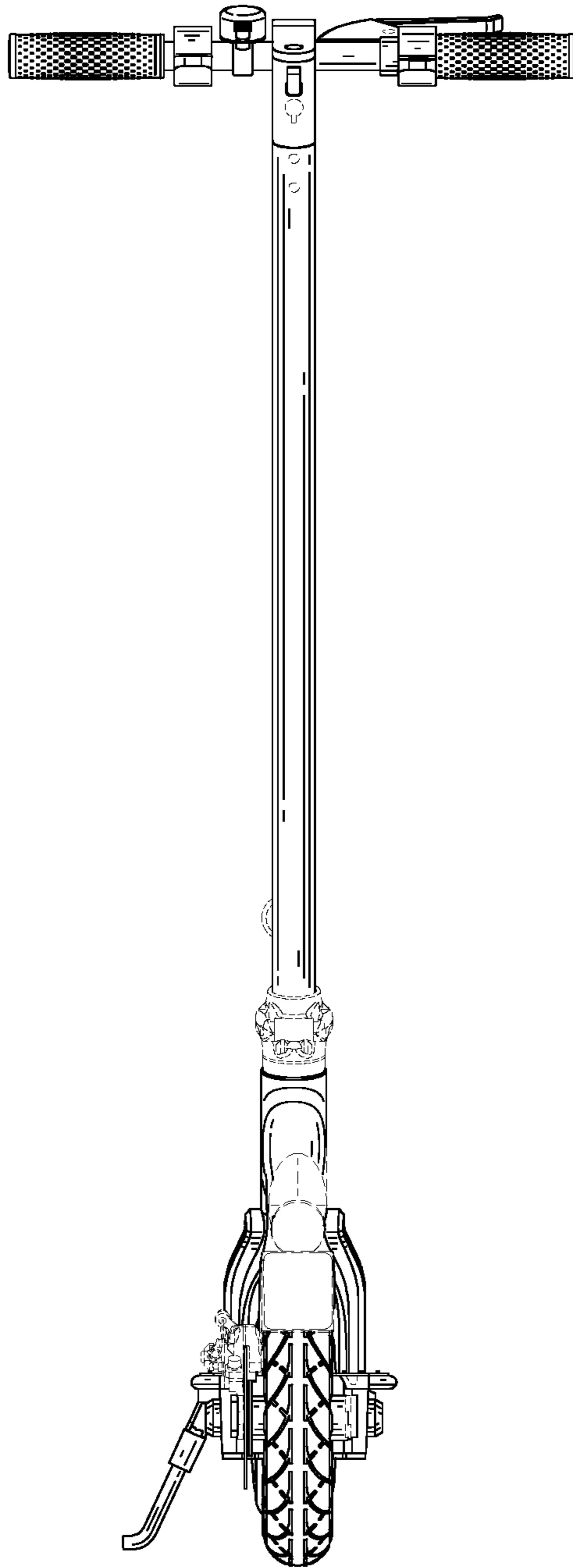

FIG. 6

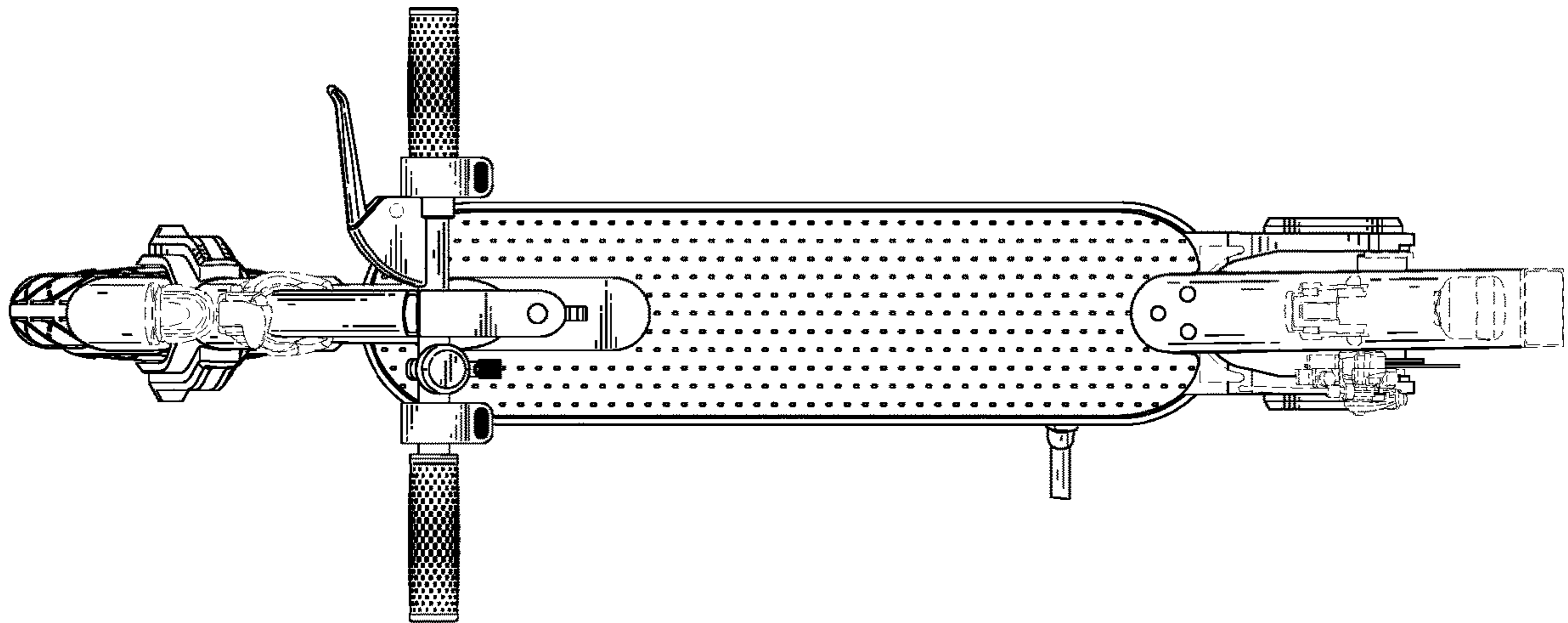

FIG. 7

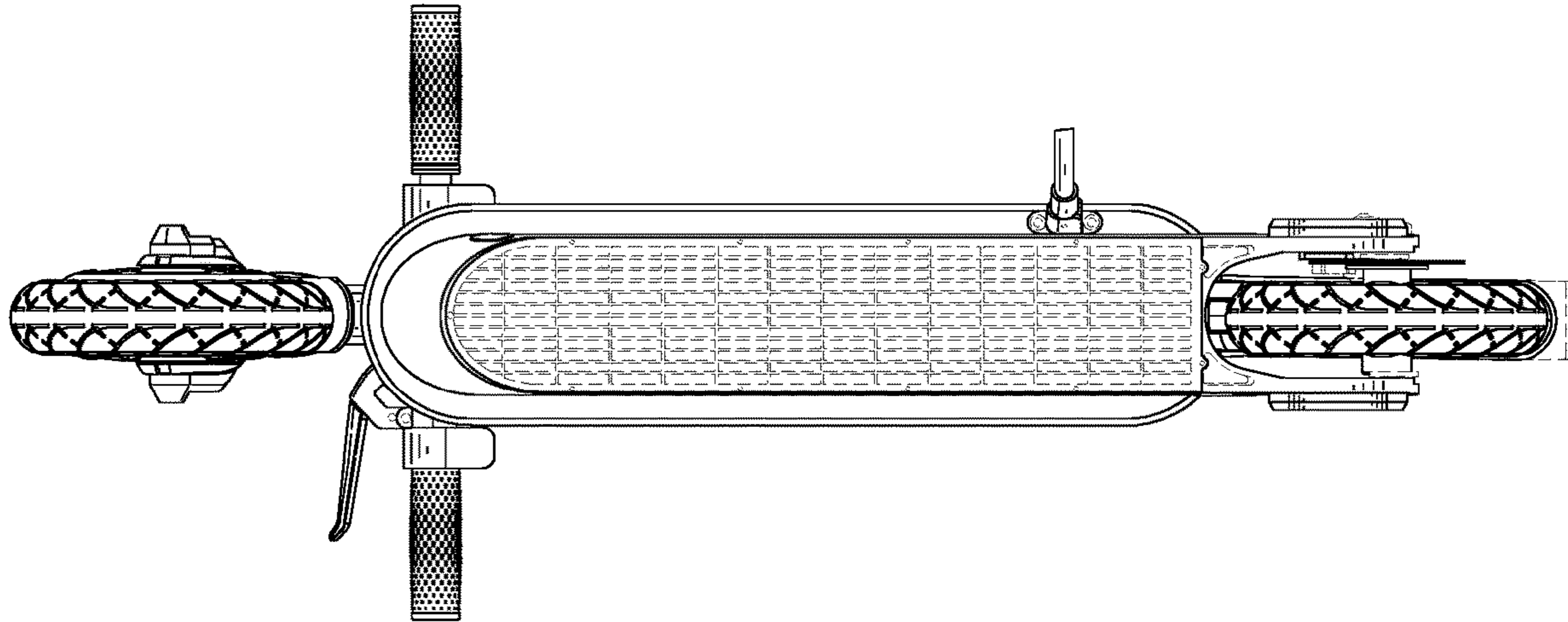

FIG. 8

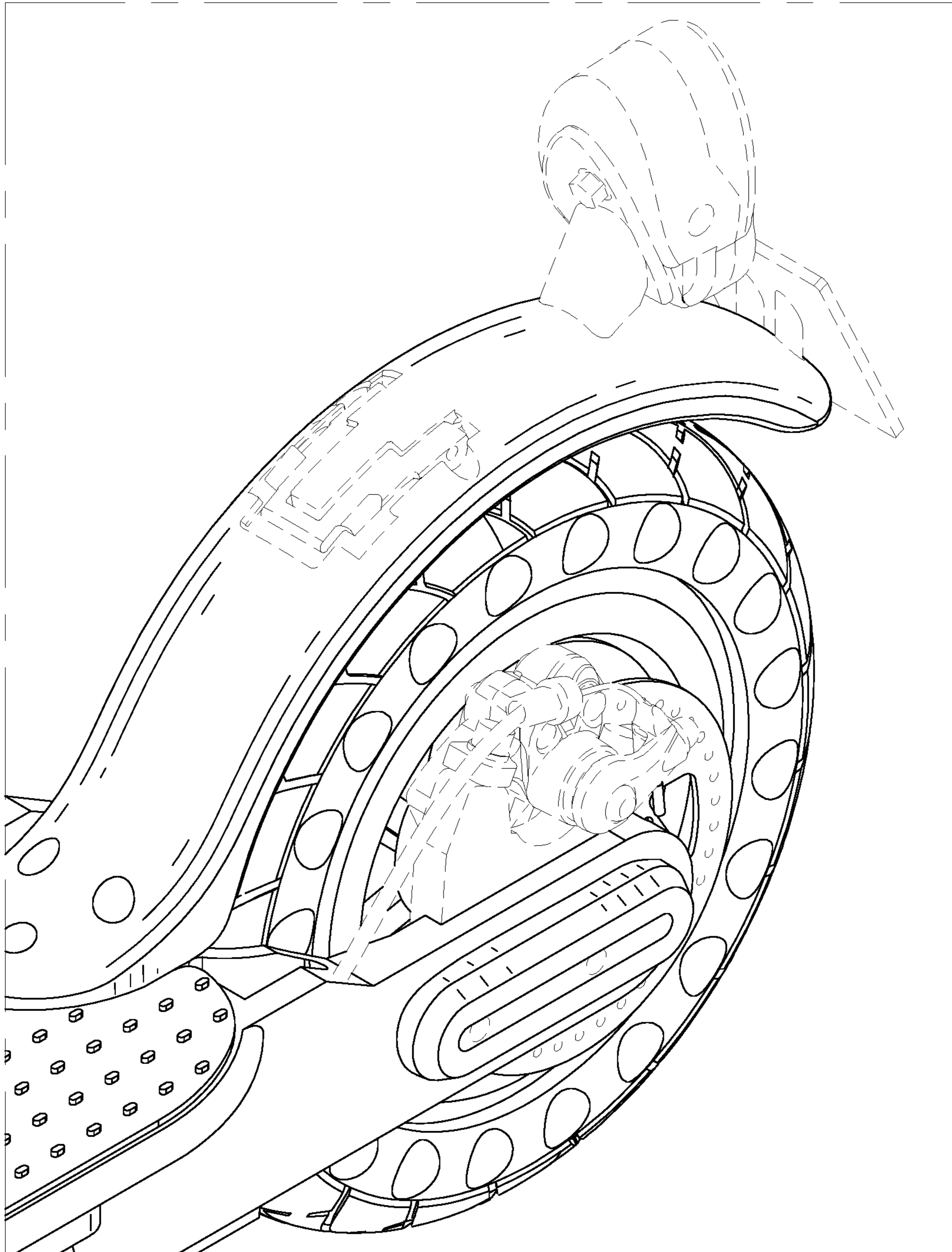

FIG. 9

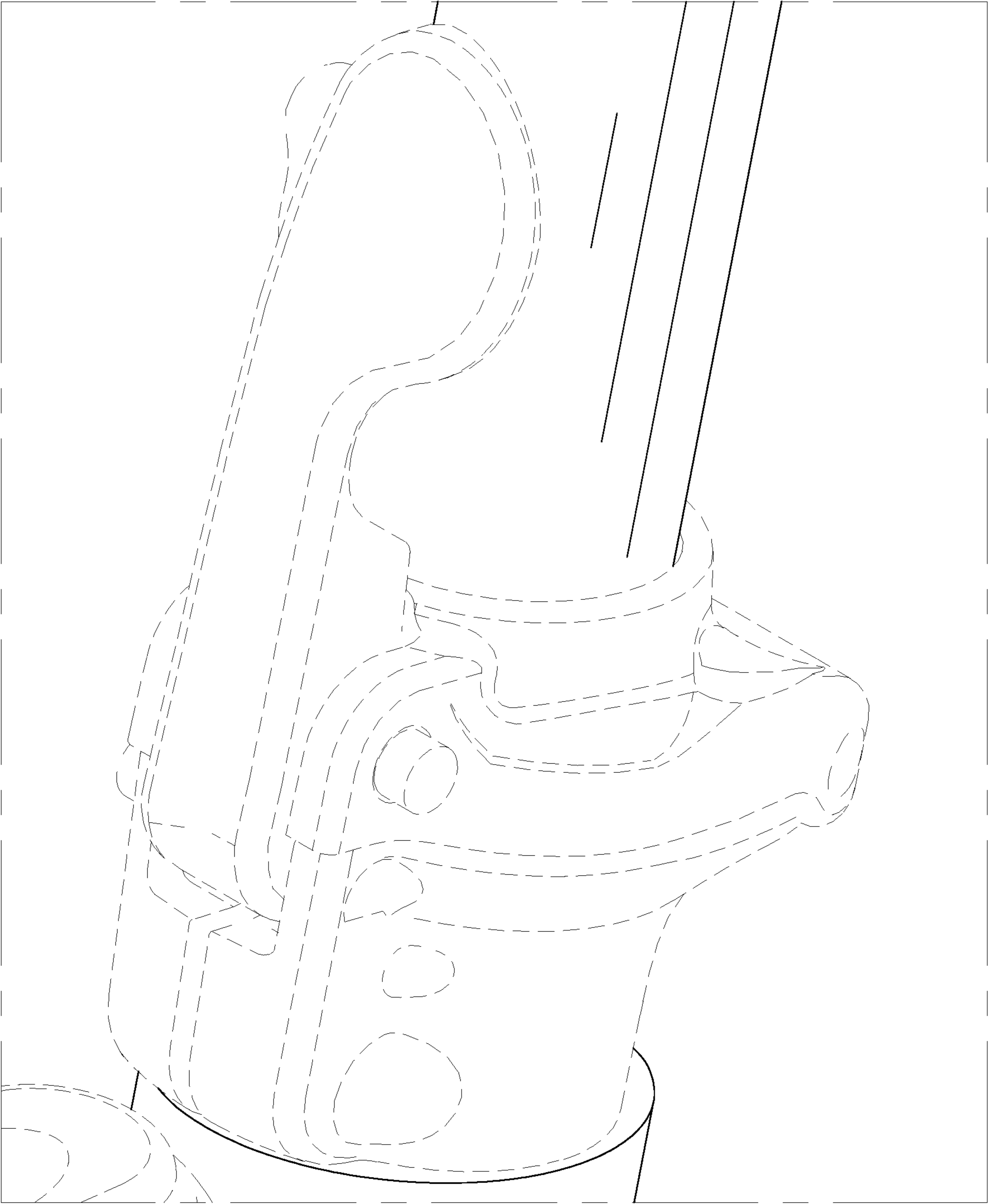

FIG. 10

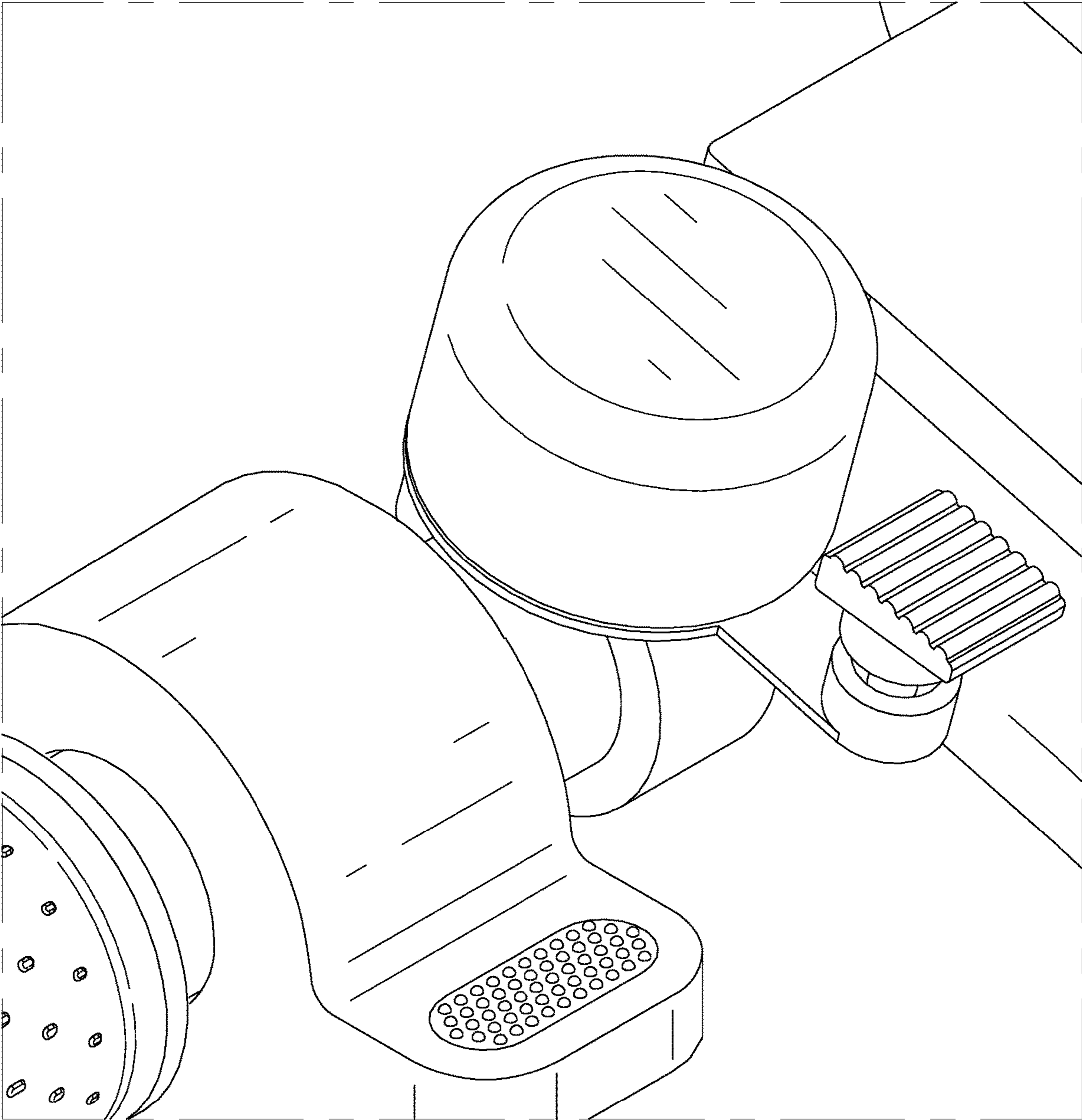

FIG. 11