



US00D923574S

(12) **United States Design Patent**
Monma et al.

(10) **Patent No.:** **US D923,574 S**
(45) **Date of Patent:** **** Jun. 29, 2021**

(54) **COIL COMPONENT**

(71) Applicant: **SUMIDA CORPORATION**, Tokyo (JP)

(72) Inventors: **Toshimasa Monma**, Natori (JP); **Shin Yamamoto**, Natori (JP)

(73) Assignee: **SUMIDA CORPORATION**

(**) Term: **15 Years**

(21) Appl. No.: **29/698,503**

(22) Filed: **Jul. 17, 2019**

(30) **Foreign Application Priority Data**

Jan. 30, 2019 (JP) 2019-001729
Jan. 30, 2019 (JP) 2019-001730

(51) **LOC (13) Cl.** **13-02**

(52) **U.S. Cl.**
USPC **D13/117**

(58) **Field of Classification Search**
USPC D13/101, 110, 117, 118, 119, 120, 121,
D13/122, 129, 133, 153, 179, 182, 183,
D13/199

(Continued)

(56) **References Cited**

U.S. PATENT DOCUMENTS

D329,041 S * 9/1992 Masuda D13/117
D427,977 S * 7/2000 Takizawa D13/182

(Continued)

FOREIGN PATENT DOCUMENTS

JP H08-213242 A 8/1996
JP 1605341 S 6/2018

OTHER PUBLICATIONS

“Bourns Shielded Power Inductor”. Found online Oct. 29, 2020 at tti.com. Reference dated Sep. 2017. Retrieved from https://www.tti.com/content/dam/ttiinc/manufacturers/bourns/products/pdf/PQ2614BLA_BHA_datasheet.pdf. (Year: 2019).*

(Continued)

Primary Examiner — Kendra Leslie Hamilton

Assistant Examiner — Amanda Christensen

(74) *Attorney, Agent, or Firm* — Harness, Dickey & Pierce, P.L.C.

(57) **CLAIM**

The ornamental design for a coil component, as shown and described.

DESCRIPTION

FIG. 1 is a front elevation view of a first embodiment of a coil component, showing our new design; FIG. 2 is a rear elevation view thereof; FIG. 3 is a right side elevation view thereof; FIG. 4 is a left side elevation view thereof; FIG. 5 is a top plan view thereof; FIG. 6 is a bottom plan view thereof; FIG. 7 is a top, front, left side perspective view thereof; and FIG. 8 is a bottom, front, left side perspective view thereof. FIG. 9 is a front elevation view of a second embodiment of a coil component, showing our new design; FIG. 10 is a rear elevation view thereof; FIG. 11 is a right side elevation view thereof; FIG. 12 is a left side elevation view thereof; FIG. 13 is a top plan view thereof; FIG. 14 is a bottom plan view thereof; FIG. 15 is a top, front, left side perspective view thereof; and, FIG. 16 is a bottom, front, left side perspective view thereof. The equal-length broken lines in the drawings depict portions of the coil component that form no part of the claimed design.

1 Claim, 16 Drawing Sheets

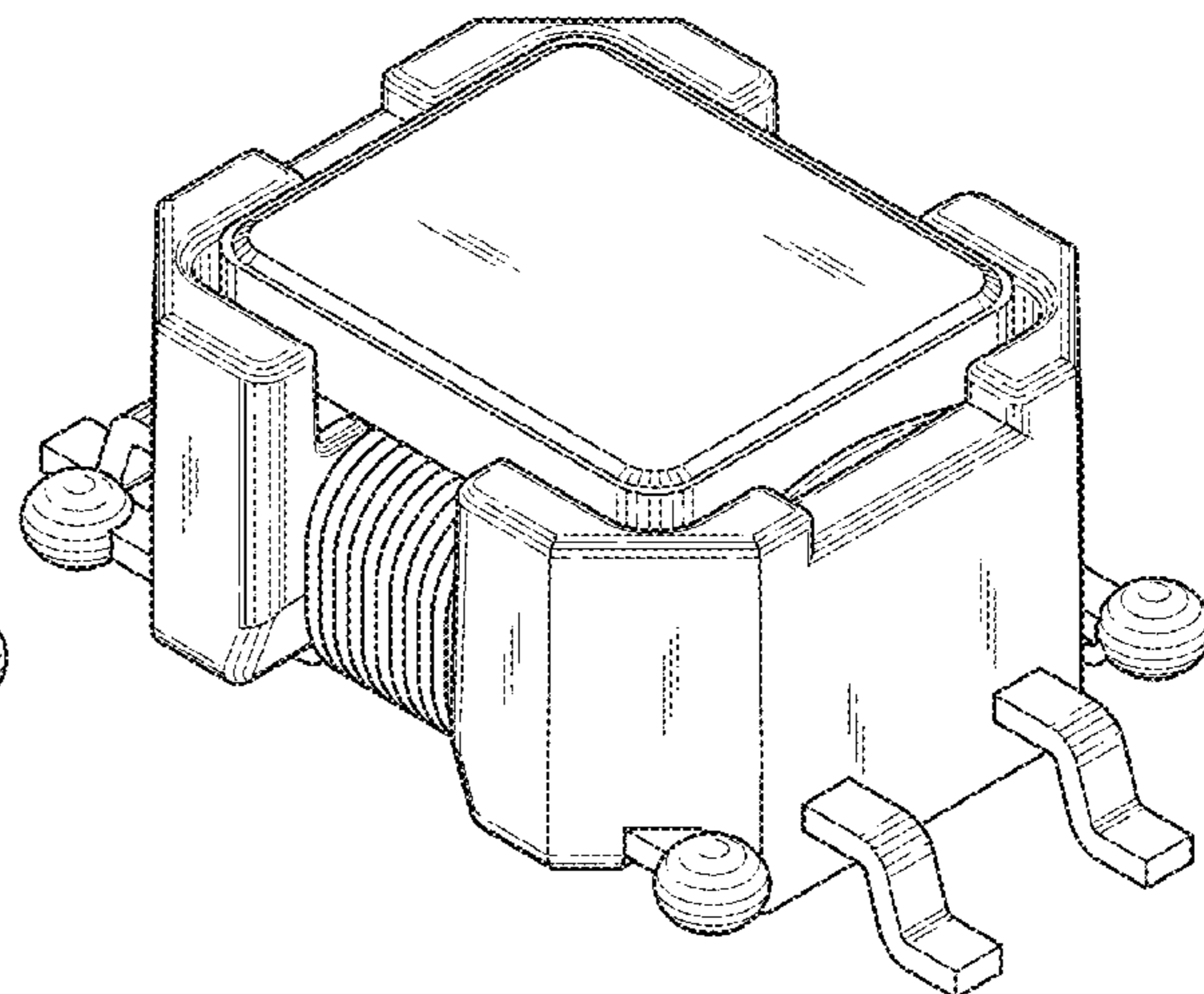
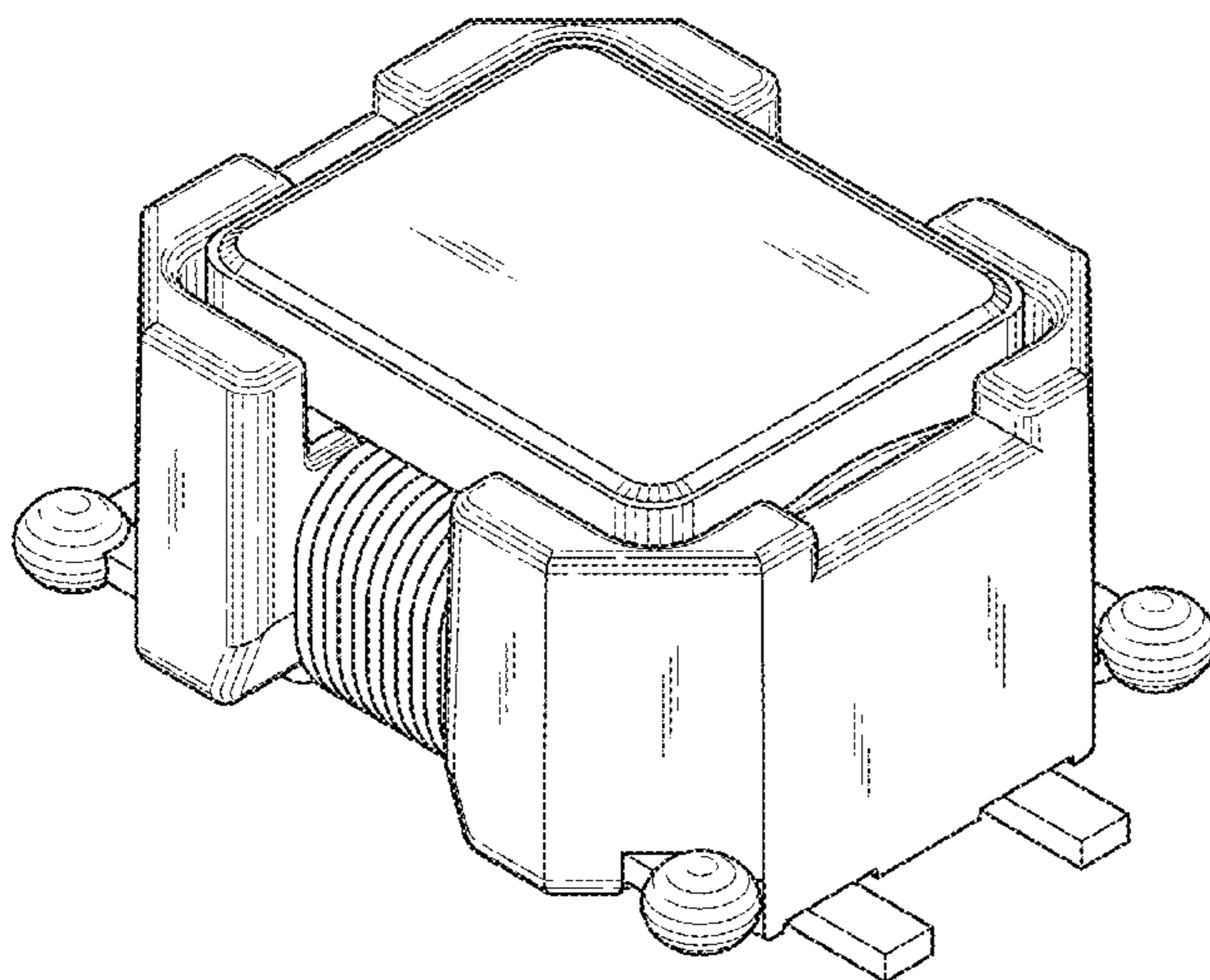

(58) **Field of Classification Search**

CPC H01F 27/00; H01F 27/2866; H01F 41/06

See application file for complete search history.

2018/0061557 A1* 3/2018 Yang H01F 27/325
2018/0330869 A1* 11/2018 Kim H01F 17/045
2020/0143971 A1* 5/2020 Sheehan H01F 27/306

OTHER PUBLICATIONS

(56)

References Cited

U.S. PATENT DOCUMENTS

D586,745 S * 2/2009 Shibata D13/117
D630,164 S * 1/2011 Kudo D13/117
D662,054 S * 6/2012 Urano D13/117
D721,651 S * 1/2015 Iwakura D13/117
D779,429 S * 2/2017 Yamada D13/117
D798,814 S * 10/2017 Takagi D13/117
10,692,639 B2 * 6/2020 Jerez H01F 27/292
2014/0009251 A1 * 1/2014 Hsu H01F 27/2866
336/57

“Common Mode Line Filter”. Found online Oct. 30, 2020 at docs.rs-online.com. Reference dated May 12, 2014. Retrieved from <https://docs.rs-online.com/d3eb/0900766b80596bca.pdf>. (Year: 2014).*
“Pulse Electronics Power”. Found online Oct. 22, 2020 at digikey.com. Reference dated Sep. 3, 2015. Retrieved from https://tineye.com/search/00f935c297ca454655afe7e6f941dacac09bf7bd?sort=crawl_date&order=asc&page=1. (Year: 2015).*
Japanese Office Action for Application No. 2019-001729 with English translation (4 pages).
Japanese Office Action for Application No. 2019-001730 with English translation (4 pages).

* cited by examiner

FIG. 1

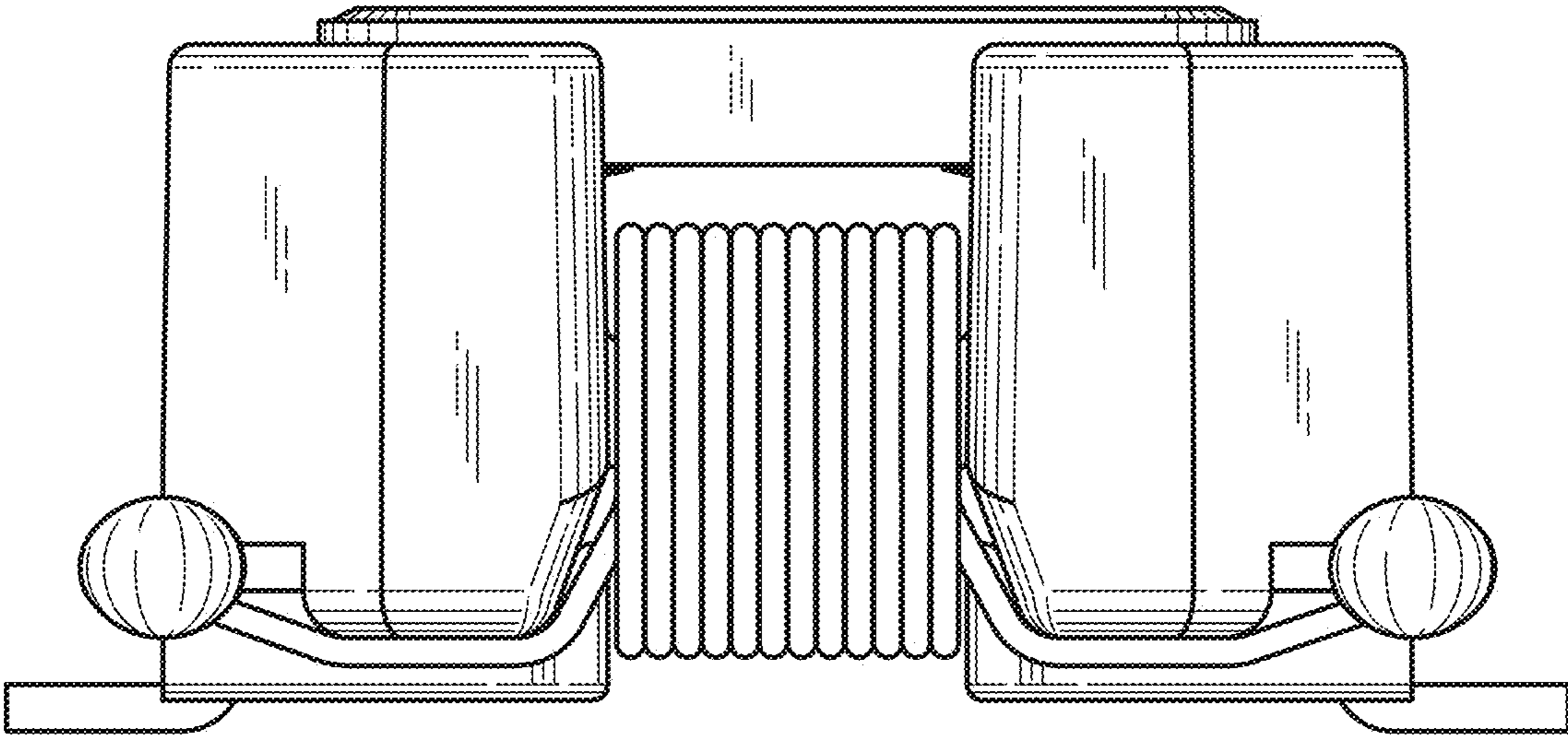

FIG.2

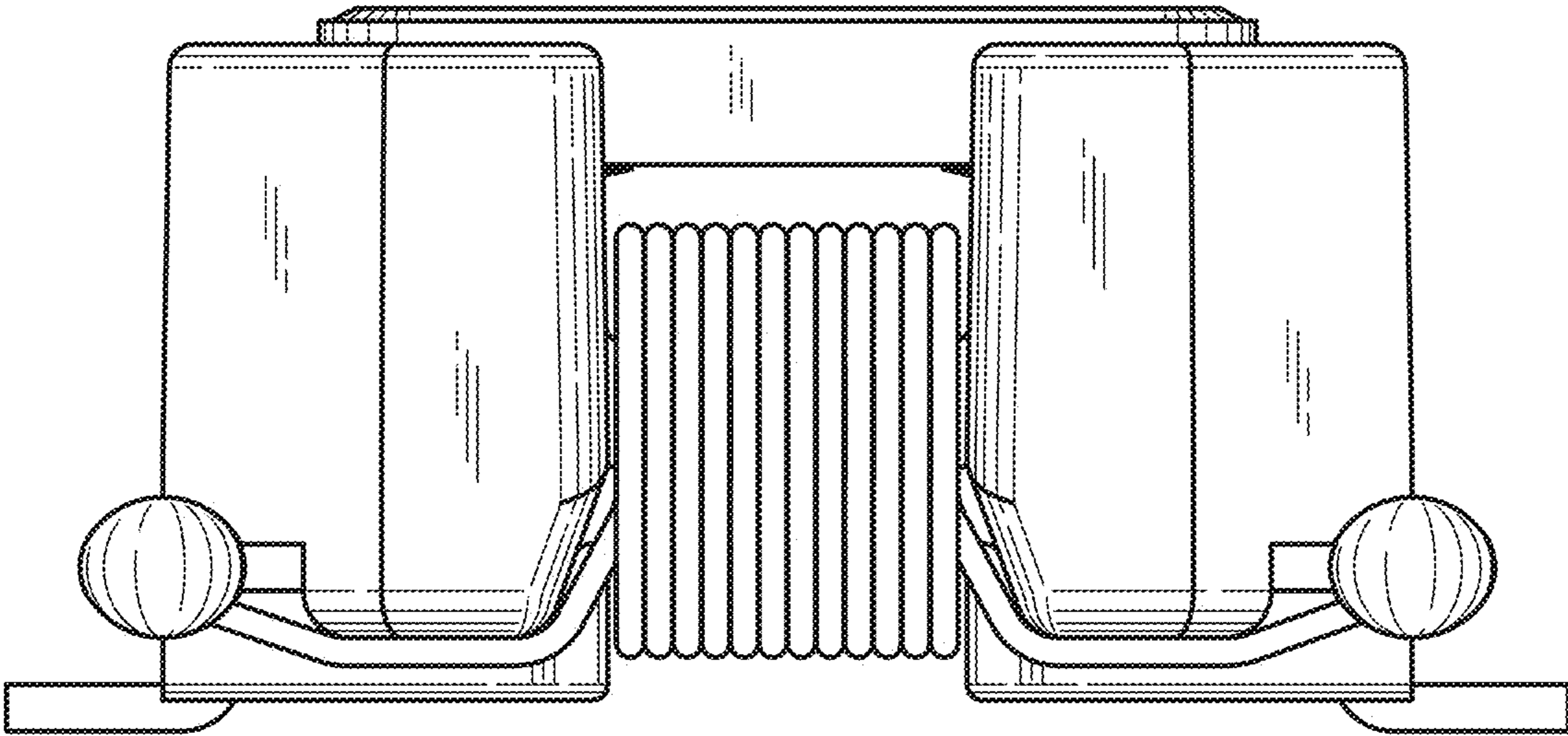

FIG.3

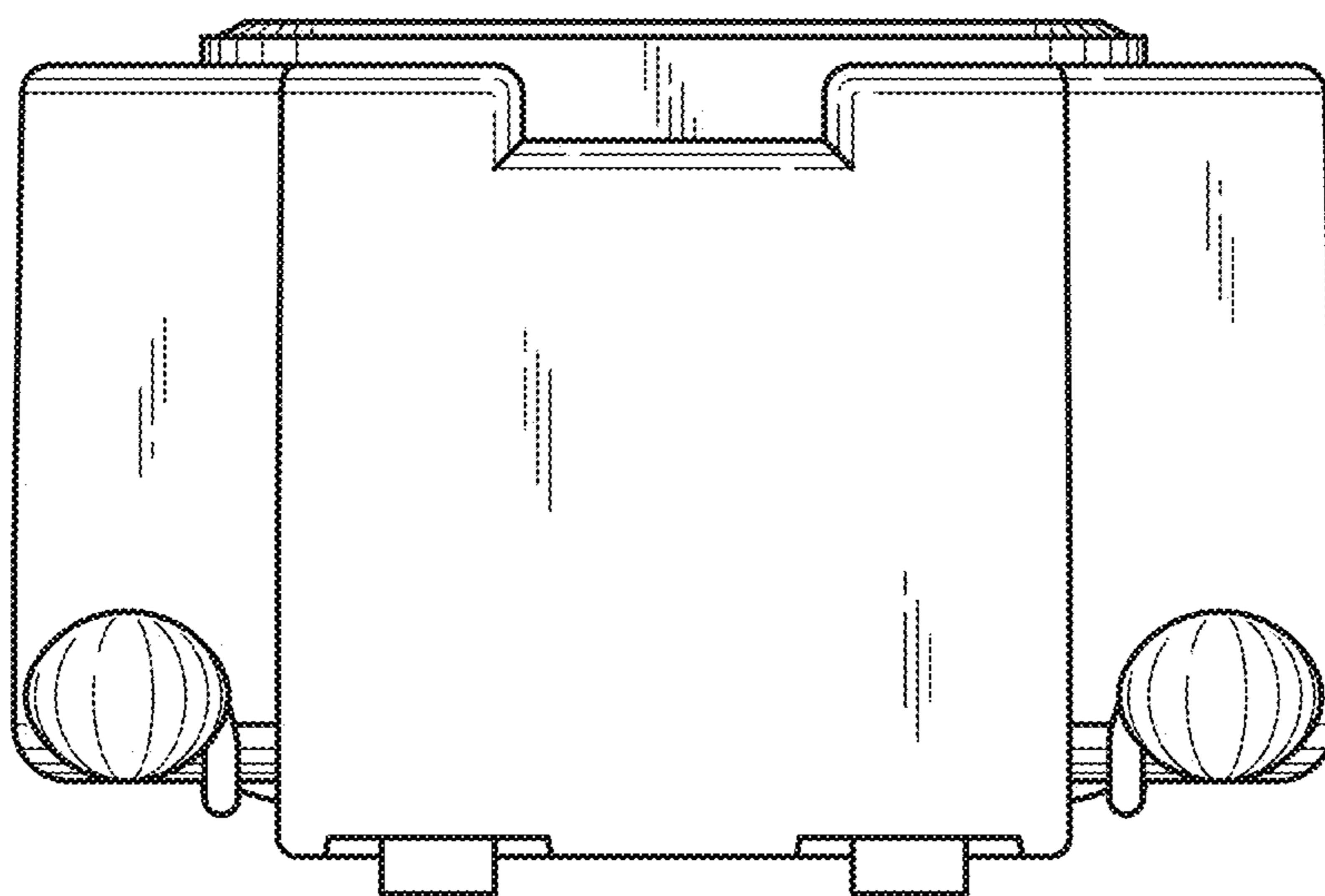

FIG.4

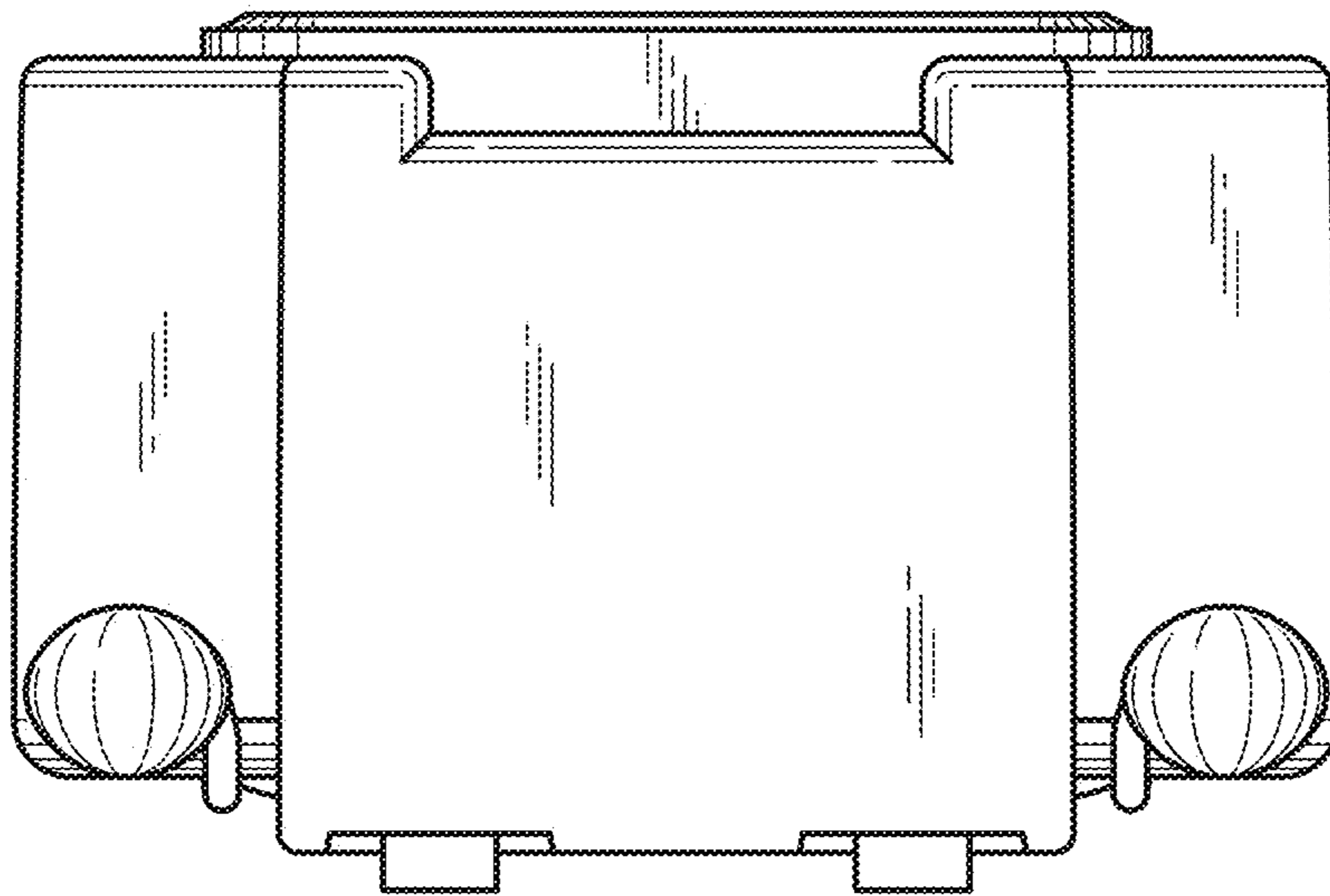

FIG.5

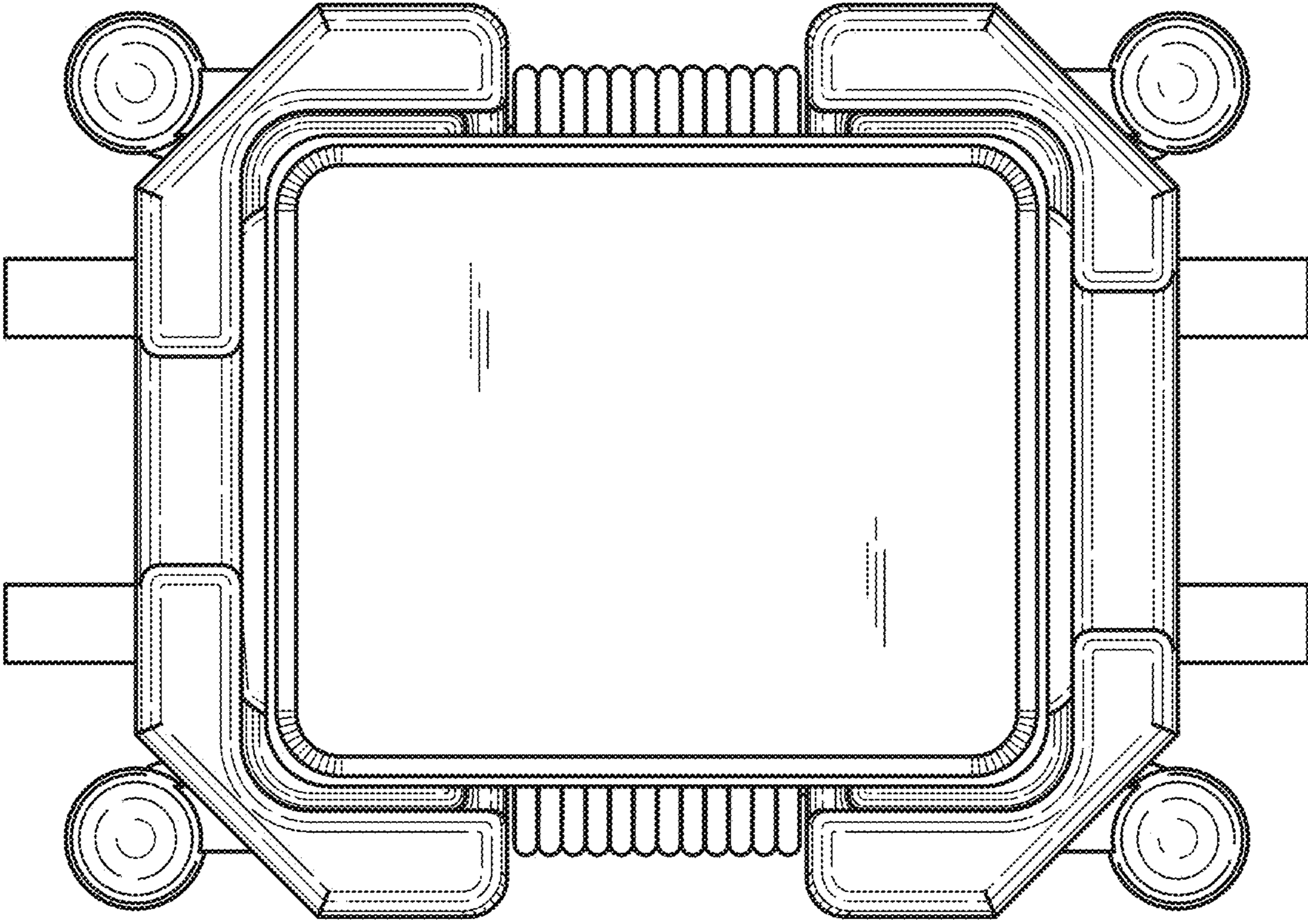

FIG.6

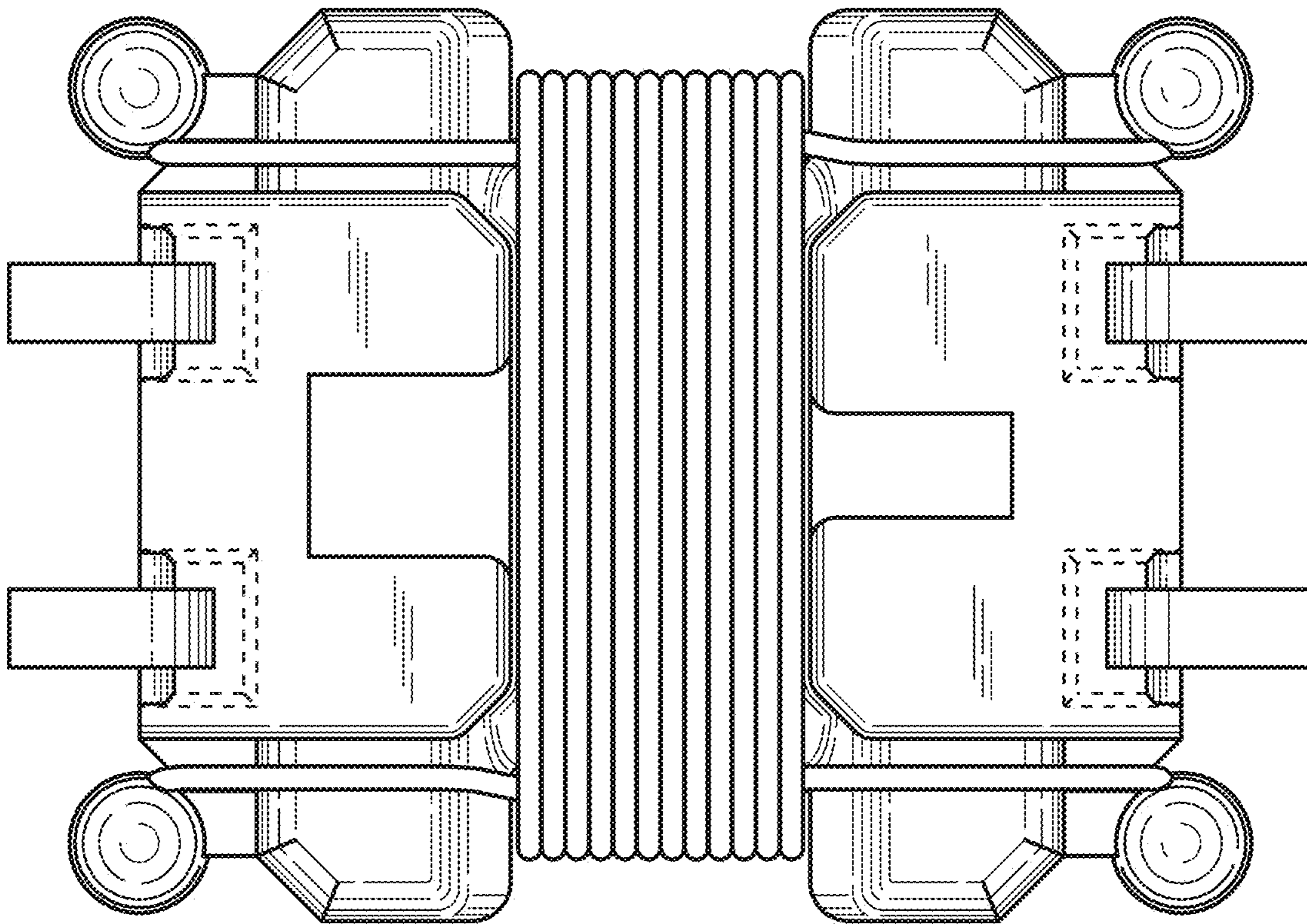

FIG.7

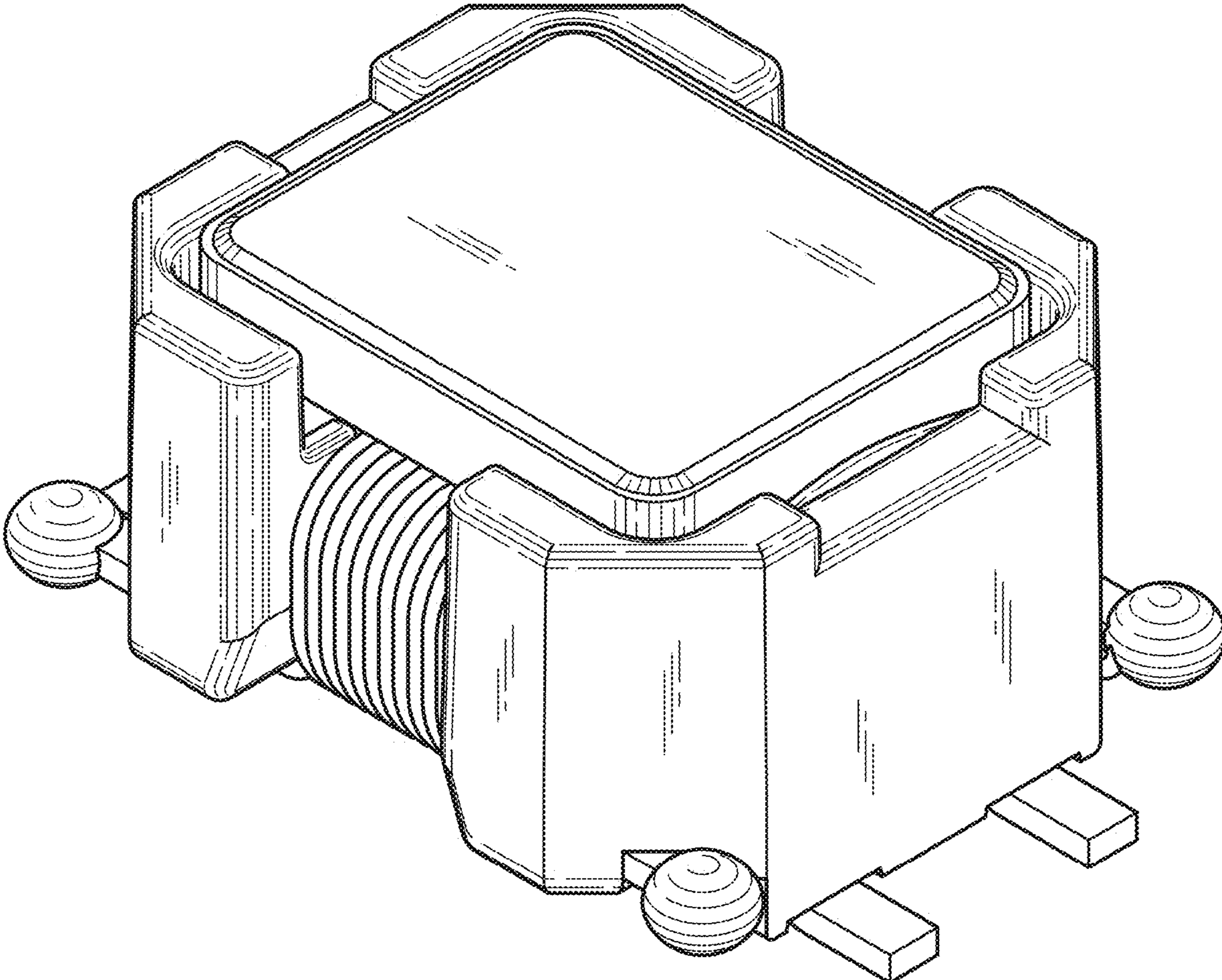

FIG.8

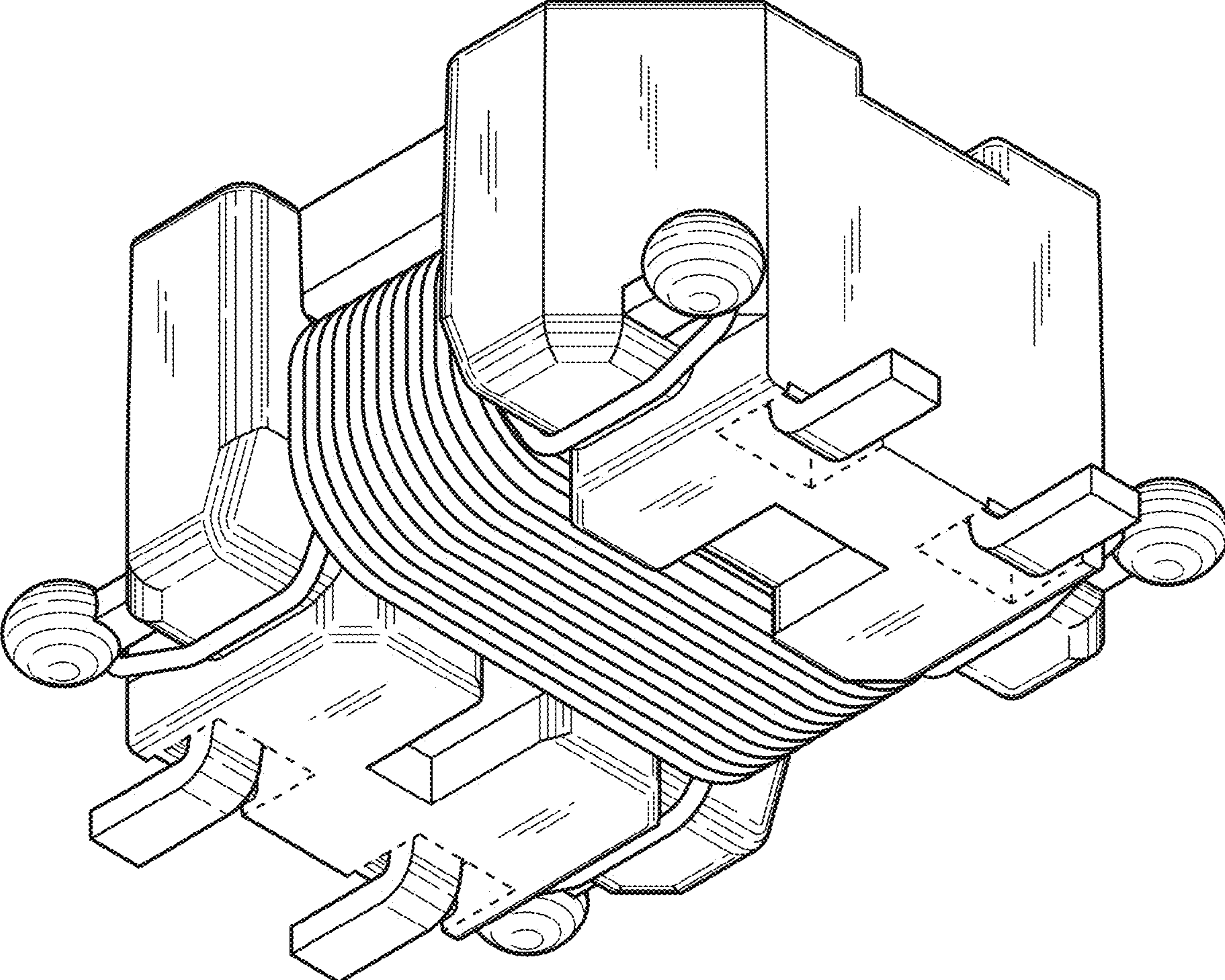

FIG.9

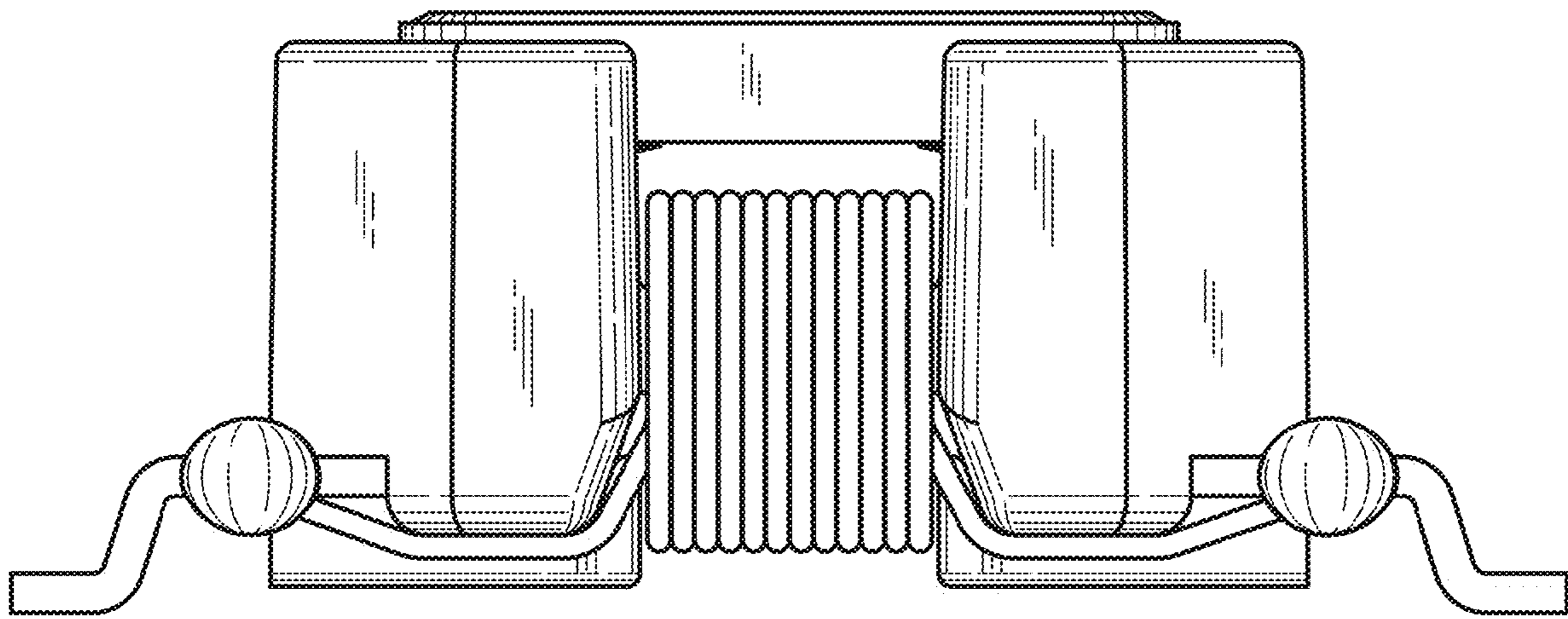

FIG. 10

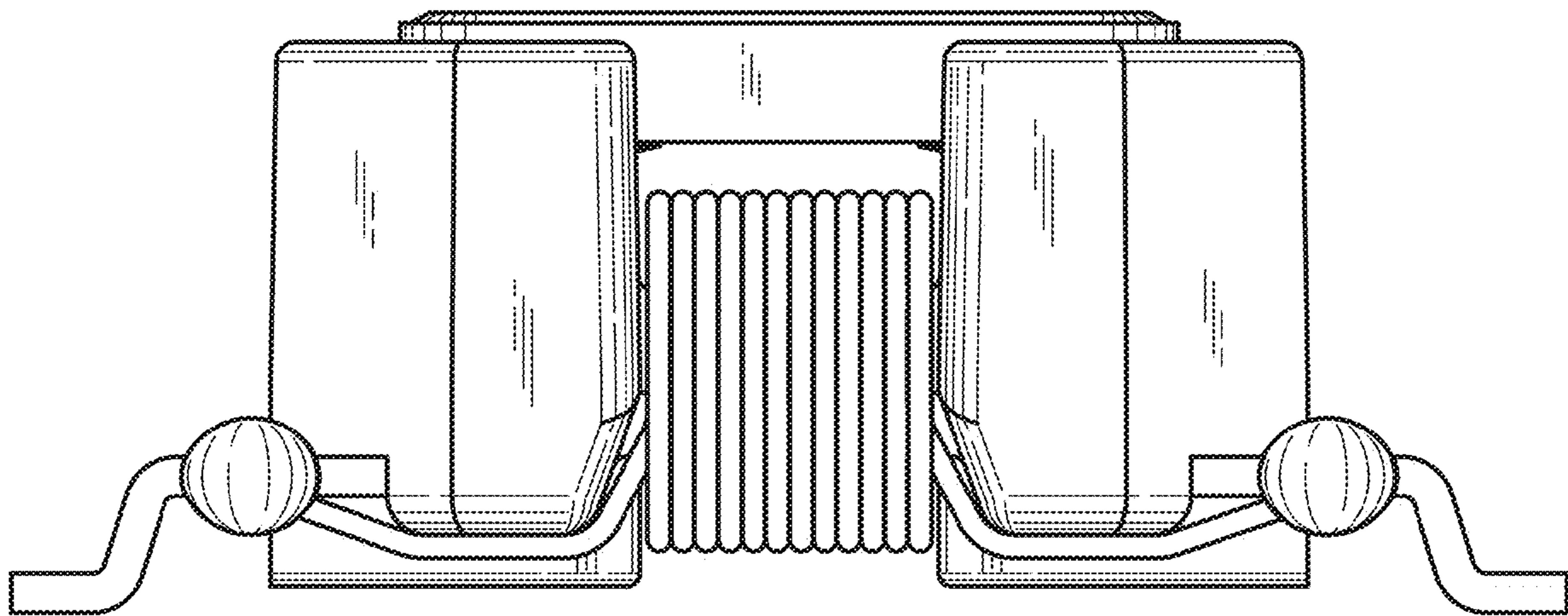

FIG. 11

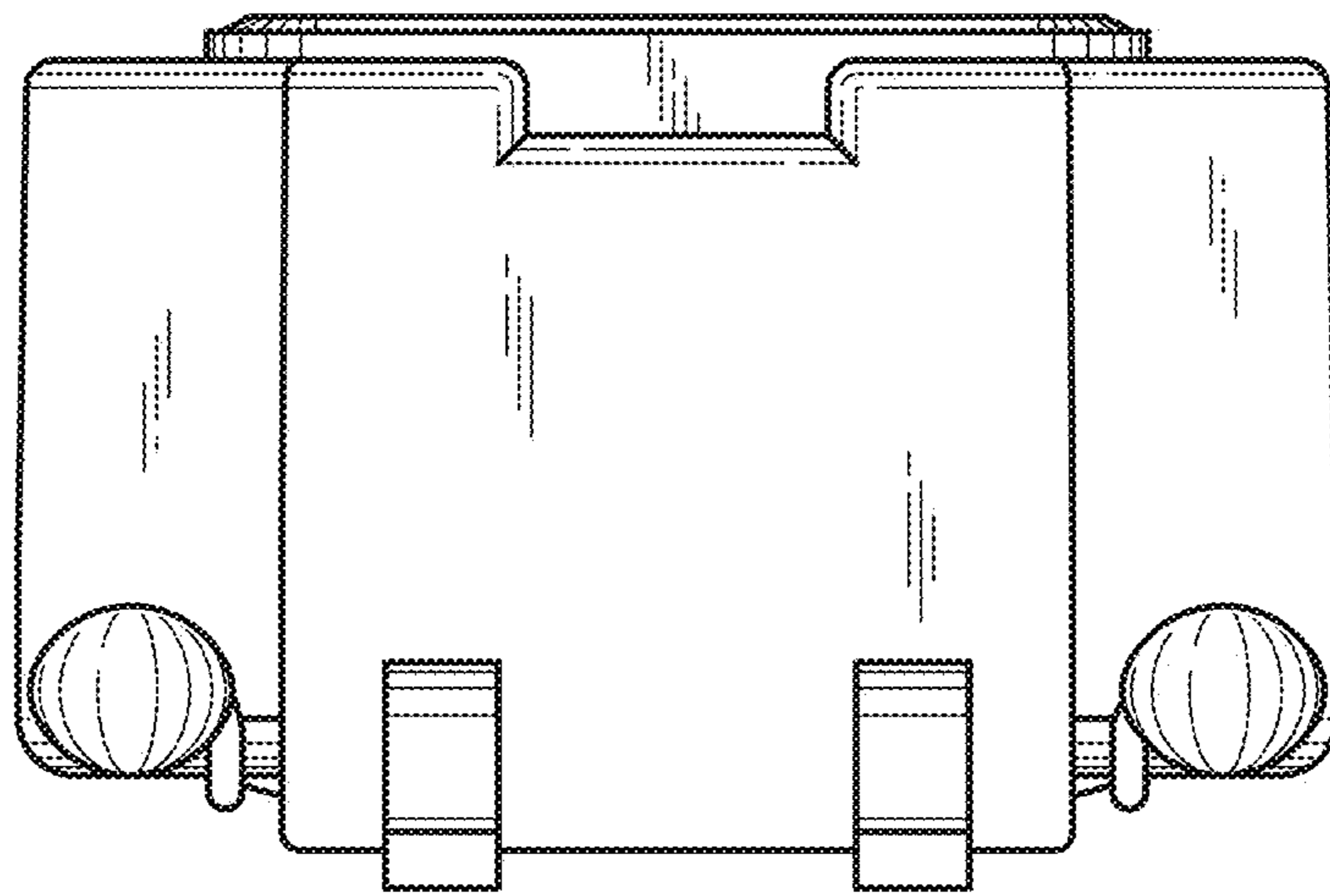

FIG. 12

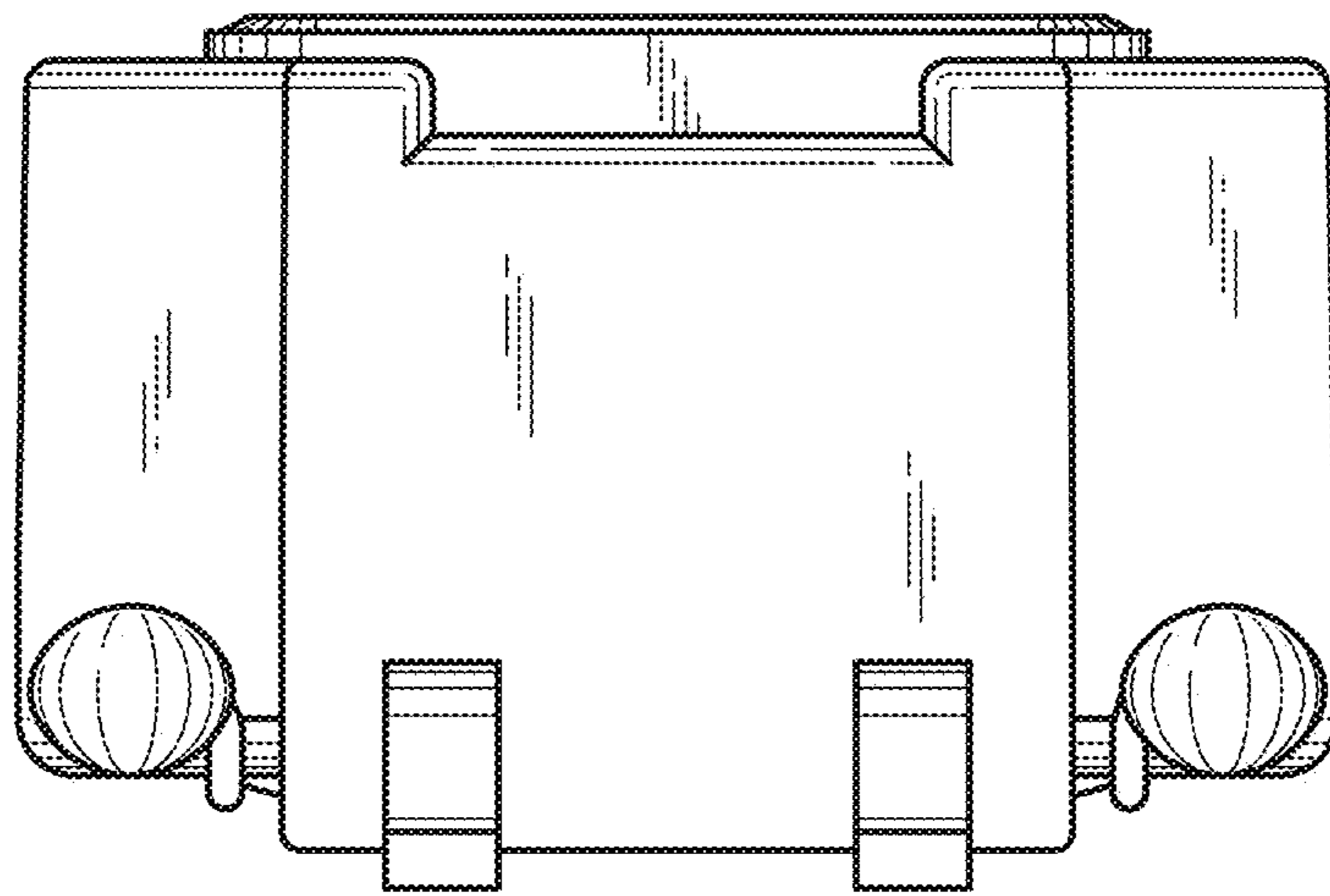

FIG. 13

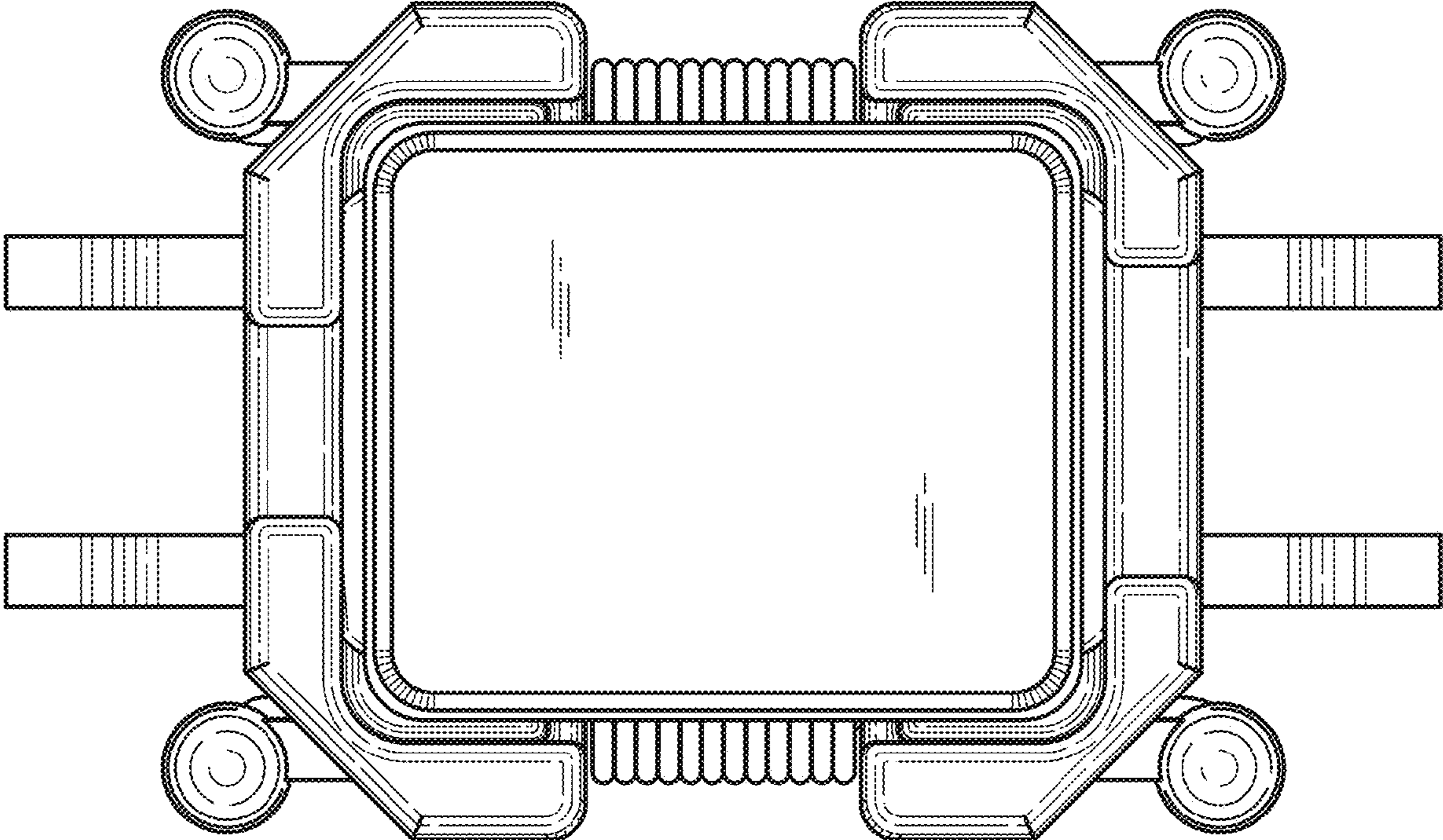

FIG.14

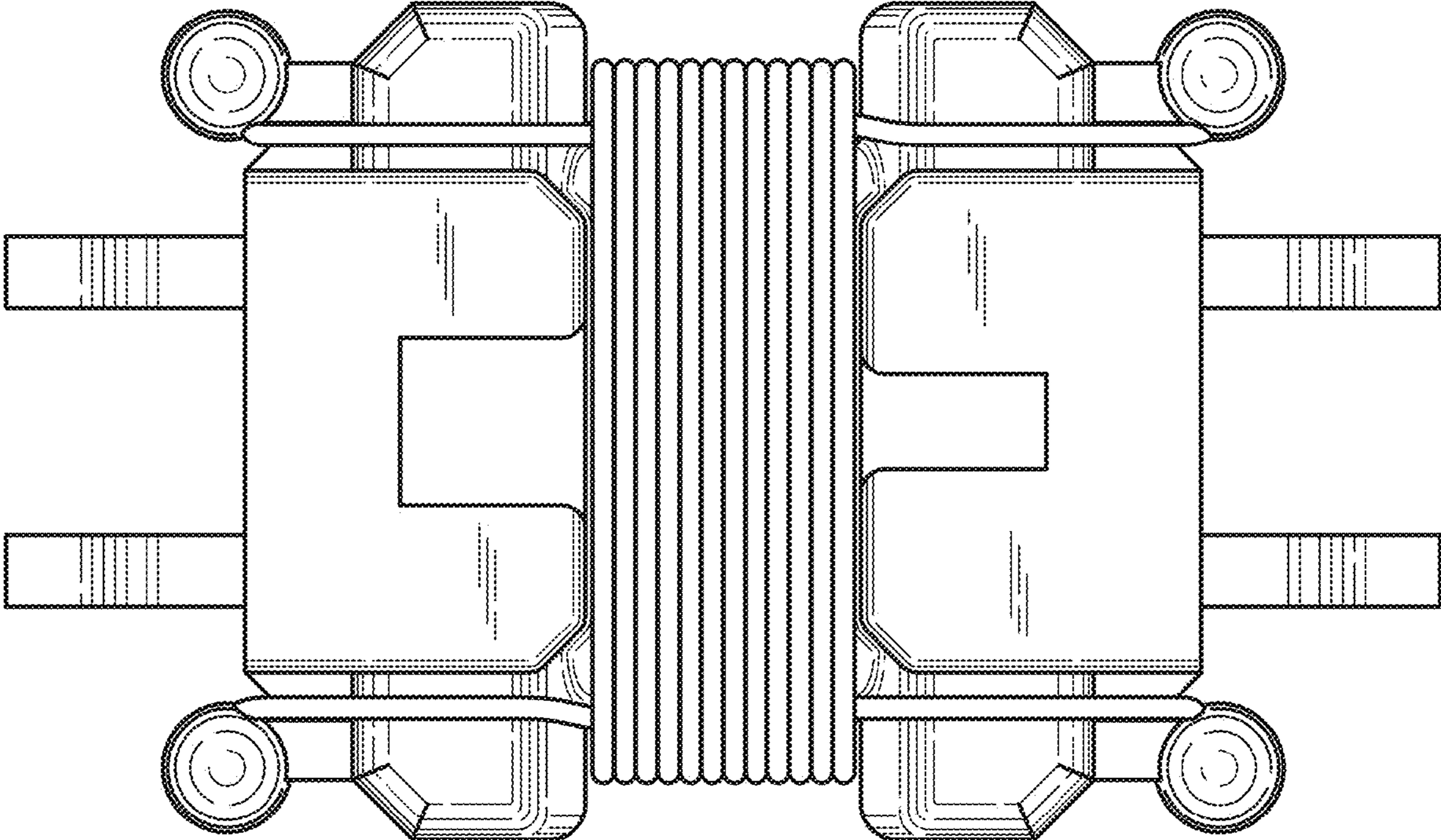

FIG.15

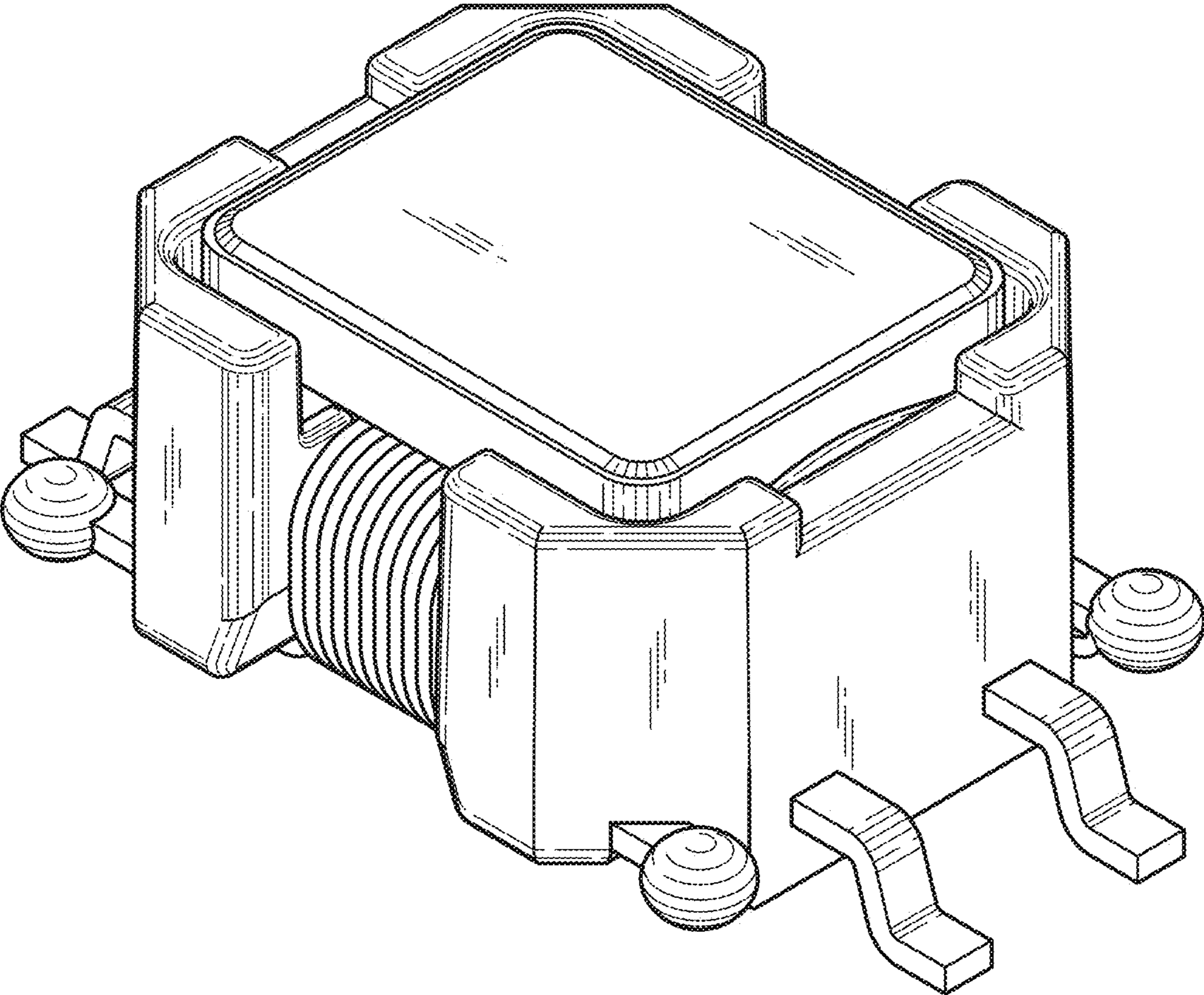

FIG.16

