



US00D923532S

(12) **United States Design Patent** (10) **Patent No.:** **US D923,532 S**
Kaoud et al. (45) **Date of Patent:** **** Jun. 29, 2021**

(54) **VEHICLE FRONT LOWER BUMPER COVER**

(71) Applicant: **Ford Global Technologies, LLC**,
Dearborn, MI (US)

(72) Inventors: **Ehab N. Kaoud**, Livonia, MI (US);
William K. Moore, West Bloomfield,
MI (US); **David Root**, Wyandotte, MI
(US); **Joshua Henry**, Detroit, MI (US);
Marc Cammeyer, Berkley, MI (US)

(73) Assignee: **Ford Global Technologies, LLC**,
Dearborn, MI (US)

(**) Term: **15 Years**

(21) Appl. No.: **29/723,955**

(22) Filed: **Feb. 12, 2020**

(51) **LOC (13) Cl.** **12-16**

(52) **U.S. Cl.**
USPC **D12/169**

(58) **Field of Classification Search**
USPC D12/82, 85, 86, 87, 88, 89, 90, 91, 92,
D12/93, 96, 97, 98, 99, 163, 164, 165,
D12/166, 167, 169, 170, 171, 172, 173,
D12/181, 184, 185, 190, 196, 216, 223,
D12/400; D21/533, 548, 552, 561;
D15/31

CPC B60R 19/00; B60R 19/02; B60R 19/24;
B60R 19/50; B60R 19/52; B60R 19/56;
B60R 2019/026; B60R 2019/525; B60R
2019/527; B60R 2019/1813; B60R
2019/1833; B60R 2019/1886; B62D
25/08; B62D 25/084; B62D 25/16; B62D
25/18; B62D 25/161; B62D 25/168;
B62D 25/182

See application file for complete search history.

(56) **References Cited**

U.S. PATENT DOCUMENTS

D543,137 S * 5/2007 Levy D12/169
D603,765 S * 11/2009 Youn D12/169

D721,303 S 1/2015 Platto
D751,010 S * 3/2016 Behmer D12/169
D811,293 S * 2/2018 Platto D12/169
D811,294 S * 2/2018 Platto D12/169
D813,743 S * 3/2018 Lee D12/169
D850,991 S * 6/2019 Bucher D12/169
D850,993 S * 6/2019 Dewitt D12/169

(Continued)

OTHER PUBLICATIONS

2021 Ford F-150, Published date unavailable [online], [retrieved on
Mar. 1, 2021], Retrieved from the Internet: [https://www.ford.com/
trucks/f150/gallery/#2021-f150-gallery-image-
1f5a8eab2b0f7bfd7a49542ec3dbd3a2-ai](https://www.ford.com/trucks/f150/gallery/#2021-f150-gallery-image-1f5a8eab2b0f7bfd7a49542ec3dbd3a2-ai) (Year: 2021).*

(Continued)

Primary Examiner — Christian P. McLean

Assistant Examiner — Adam C Mager

(74) *Attorney, Agent, or Firm* — Michael Spenner

(57) **CLAIM**

The ornamental design for a vehicle front lower bumper
cover, as shown and described.

DESCRIPTION

FIG. 1 is a front elevational view of a vehicle front lower
bumper cover, showing our new design;
FIG. 2 is a left side elevational view thereof;
FIG. 3 is a right side elevational view thereof;
FIG. 4 is a top plan view thereof;
FIG. 5 is a bottom plan view thereof;
FIG. 6 is a bottom, front and left side perspective view
thereof; and,
FIG. 7 is a top, front and left side perspective view thereof.
The claimed design is indicated by the relatively dark
portions in the figures. The de-emphasized and relatively
light portions form no part of the claimed design.

1 Claim, 7 Drawing Sheets



(56)

References Cited

U.S. PATENT DOCUMENTS

D850,995 S * 6/2019 Dewitt D12/169
D855,507 S * 8/2019 Blanski D12/169
D875,623 S * 2/2020 Kim D12/169
D906,195 S * 12/2020 Bischoff D12/169

OTHER PUBLICATIONS

Andrew Wendler, The 2021 Ford F-150, Spied Testing, Looks Pretty Evolutionary, May 8, 2019 <https://www.caranddriver.com/news/a27409108/2021-ford-f-150-pickup-spied/>.

* cited by examiner

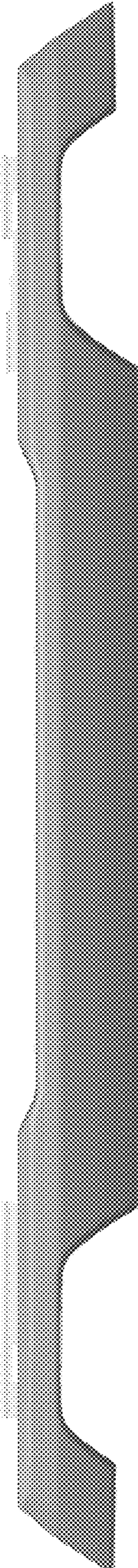

Fig. 1

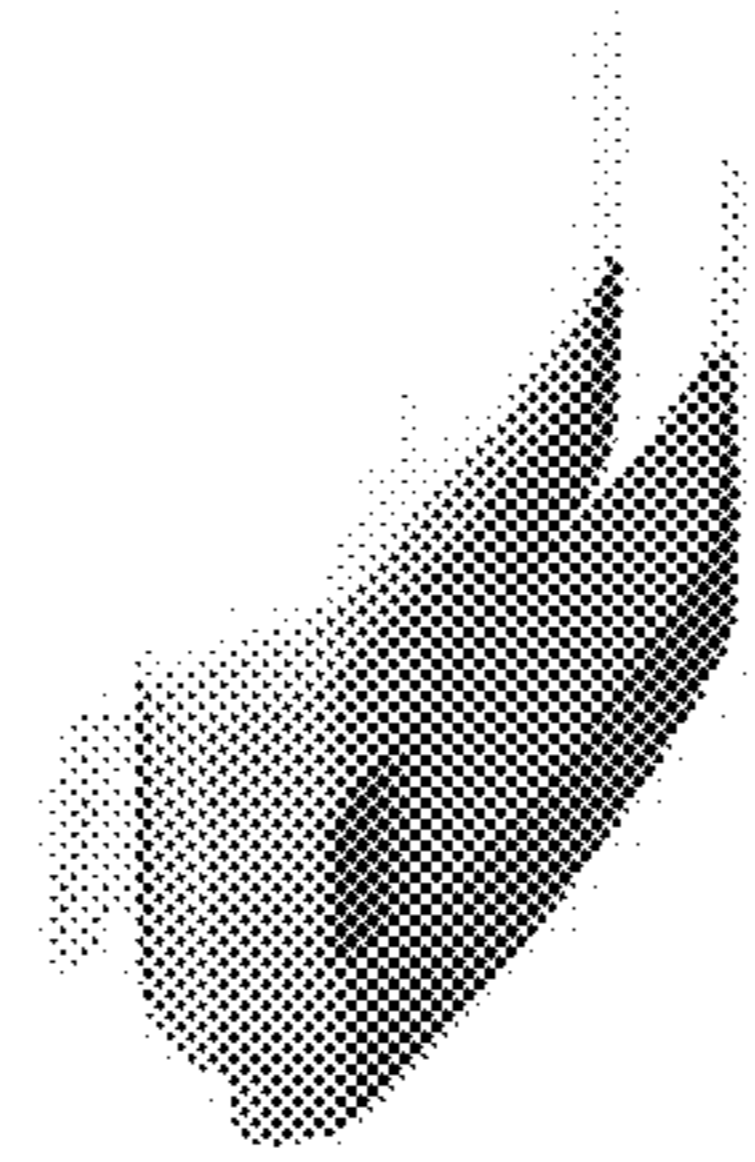

Fig. 2



Fig. 3

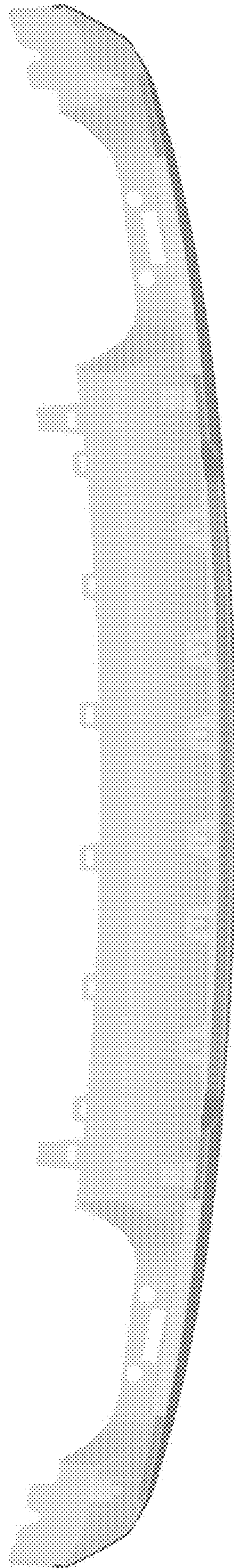

Fig.4

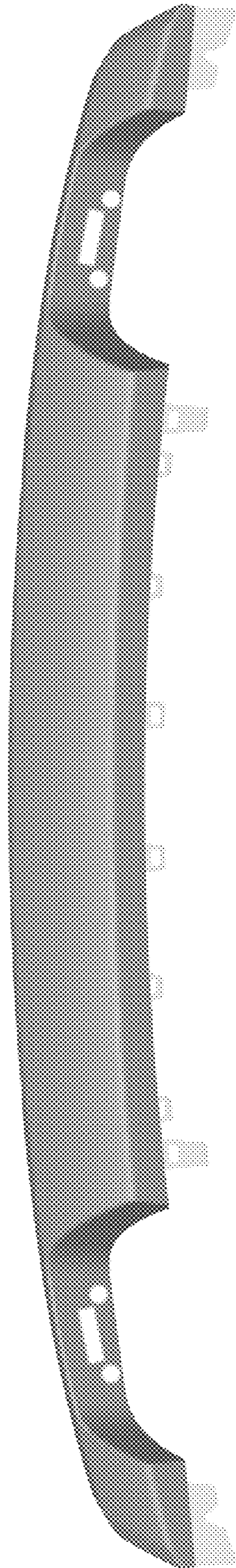

Fig. 5

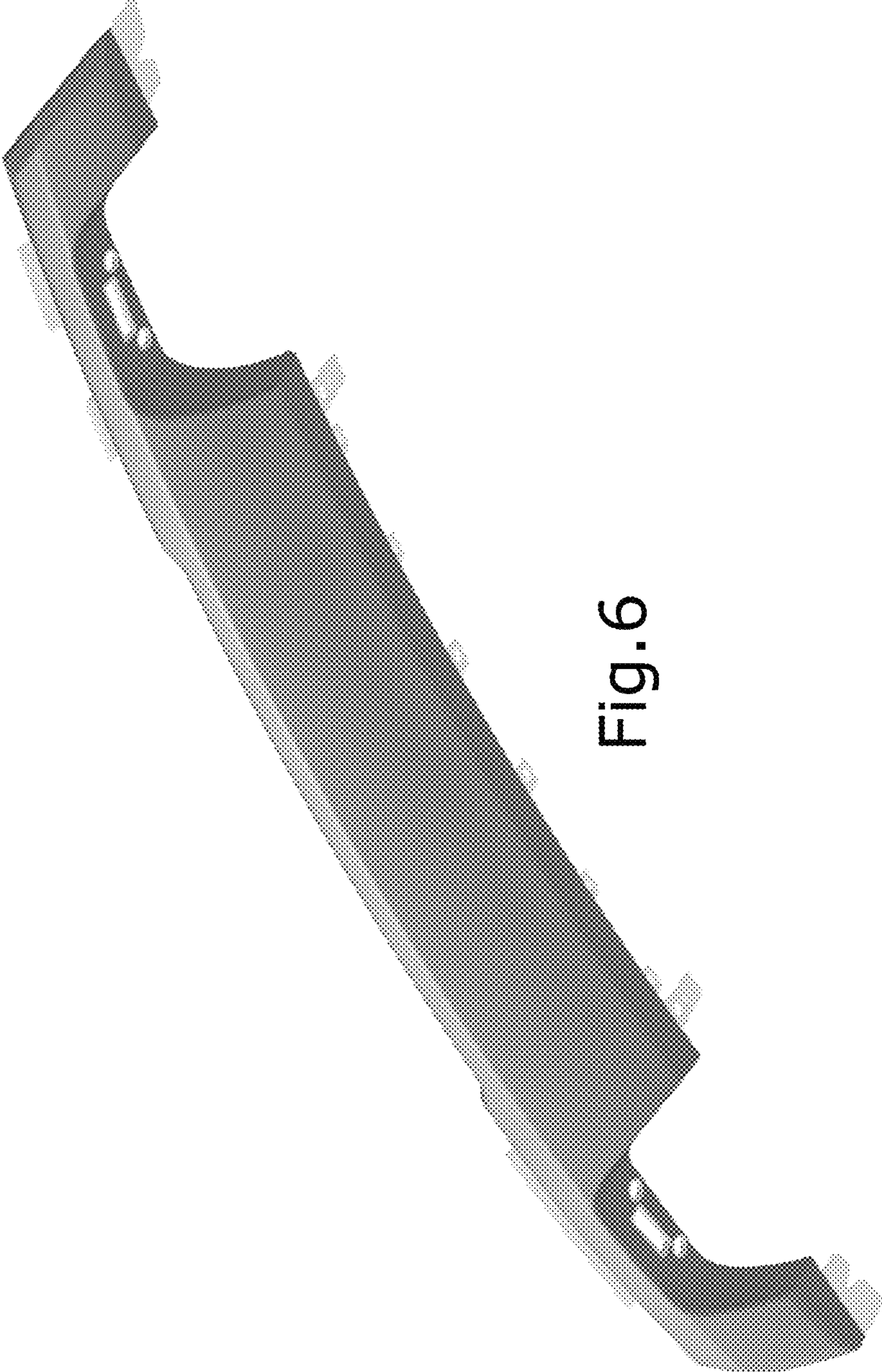

Fig. 6

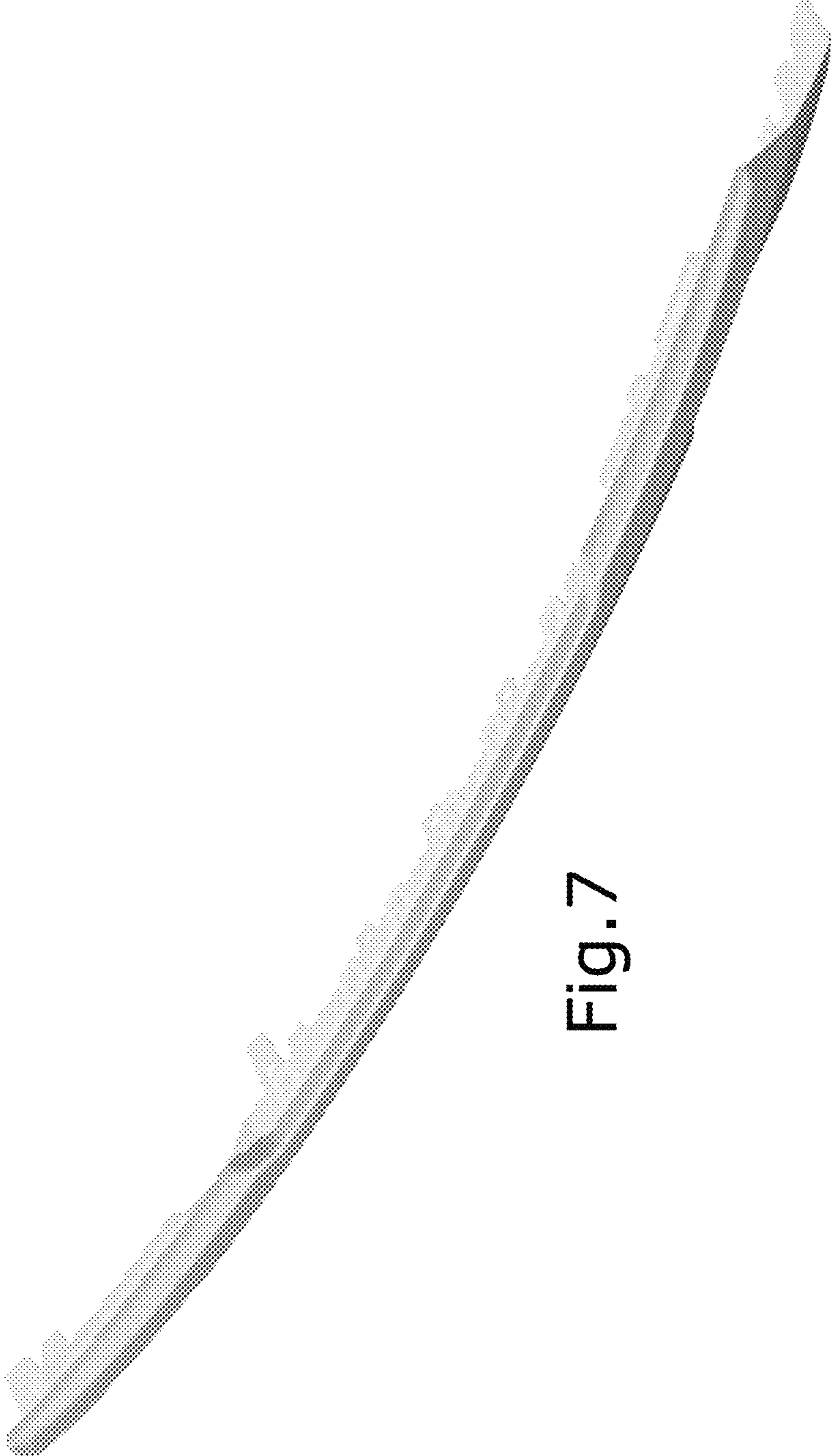

Fig. 7