



US00D922682S

(12) **United States Design Patent**
Sikora et al.

(10) **Patent No.:** **US D922,682 S**
(45) **Date of Patent:** **** Jun. 15, 2021**

- (54) **ELECTRIC DRY SHAVER**
- (71) Applicant: **Braun GmbH**, Kronberg (DE)
- (72) Inventors: **Bernhard Sikora**, Kelkheim (DE);
Wolfgang Stegmann, Frankfurt (DE)
- (73) Assignee: **Braun GmbH**, Kronberg (DE)
- (**) Term: **15 Years**
- (21) Appl. No.: **29/679,544**
- (22) Filed: **Feb. 7, 2019**
- (30) **Foreign Application Priority Data**

Aug. 10, 2018 (WO) 8514901

- (51) **LOC (13) Cl.** **28-03**
- (52) **U.S. Cl.**
USPC **D28/51**
- (58) **Field of Classification Search**
USPC D28/49-54
CPC B26B 19/00-08; B26B 19/10-12; B26B
19/20-24; B26B 19/26-265; B26B
19/38-3826; B26B 19/3873-3893; B26B
19/42

See application file for complete search history.

(56) **References Cited**

U.S. PATENT DOCUMENTS

D337,857 S	7/1993	Nakashima et al.	
D351,927 S	10/1994	Nakashima et al.	
6,381,849 B2	5/2002	Eichhorn et al.	
6,601,302 B2	8/2003	Andrew	
D657,912 S *	4/2012	Yoon	D28/54
D668,387 S *	10/2012	Grabes	D28/51
D677,836 S *	3/2013	Grabes	D28/51

D689,242 S *	9/2013	Grabes	D28/54
D690,880 S *	10/2013	Grabes	D28/51
D702,882 S *	4/2014	Grabes	D28/51
D713,994 S *	9/2014	Grabes	D28/54
D718,900 S	12/2014	Kikuchi	
D751,252 S *	3/2016	Grabes	D28/51
D753,342 S	4/2016	Okabe	
D763,509 S *	8/2016	Teteak	D28/51
D799,118 S	10/2017	Ino	
D813,458 S	3/2018	Okabe	
10,486,316 B2 *	11/2019	Erndt	B26B 19/046
10,486,318 B2 *	11/2019	Bady	B26B 19/3813
2012/0151774 A1 *	6/2012	Shimizu	B26B 19/10 30/43.92
2015/0314461 A1 *	11/2015	Man Wong	B26B 19/06 30/43.91
2016/0176058 A1 *	6/2016	Piesker	B26B 19/042 30/43.9
2018/0085940 A1 *	3/2018	Krauss	B26B 19/284
2018/0085945 A1 *	3/2018	Bady	B26B 19/143

* cited by examiner

Primary Examiner — Jennifer Rivard

(74) *Attorney, Agent, or Firm* — Kevin C. Johnson

(57) **CLAIM**

The ornamental design for an electric dry shaver, as shown and described.

DESCRIPTION

FIG. 1 is a perspective view of an electric dry shaver;
FIG. 2 is a front view thereof;
FIG. 3 is a right side view thereof;
FIG. 4 is a rear view thereof;
FIG. 5 is a left side view thereof;
FIG. 6 is a top plan view thereof; and,
FIG. 7 is a bottom view thereof.

1 Claim, 7 Drawing Sheets

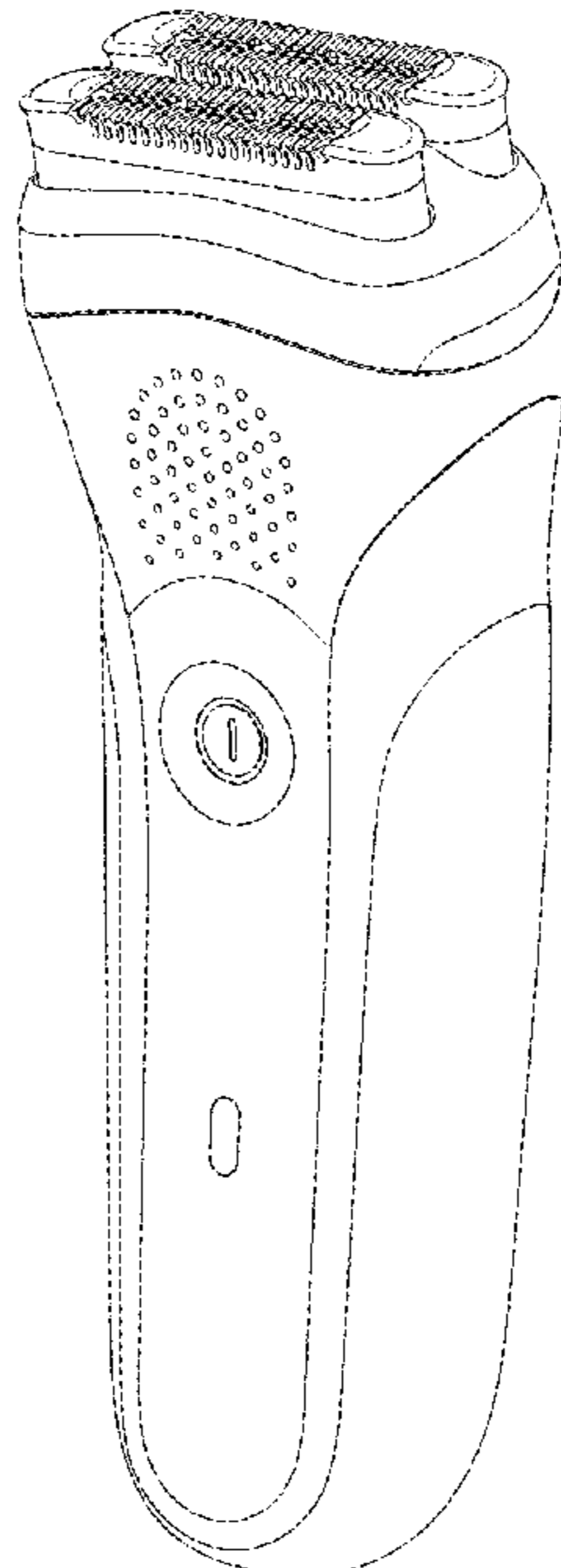

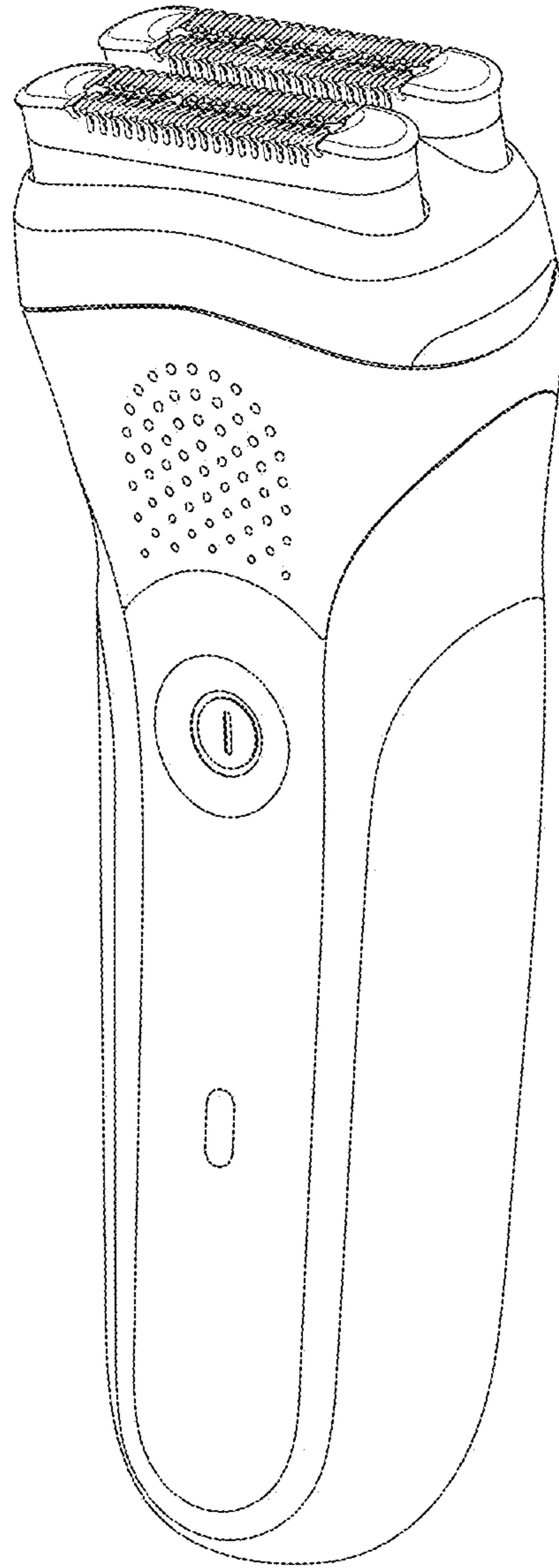

Figure 1

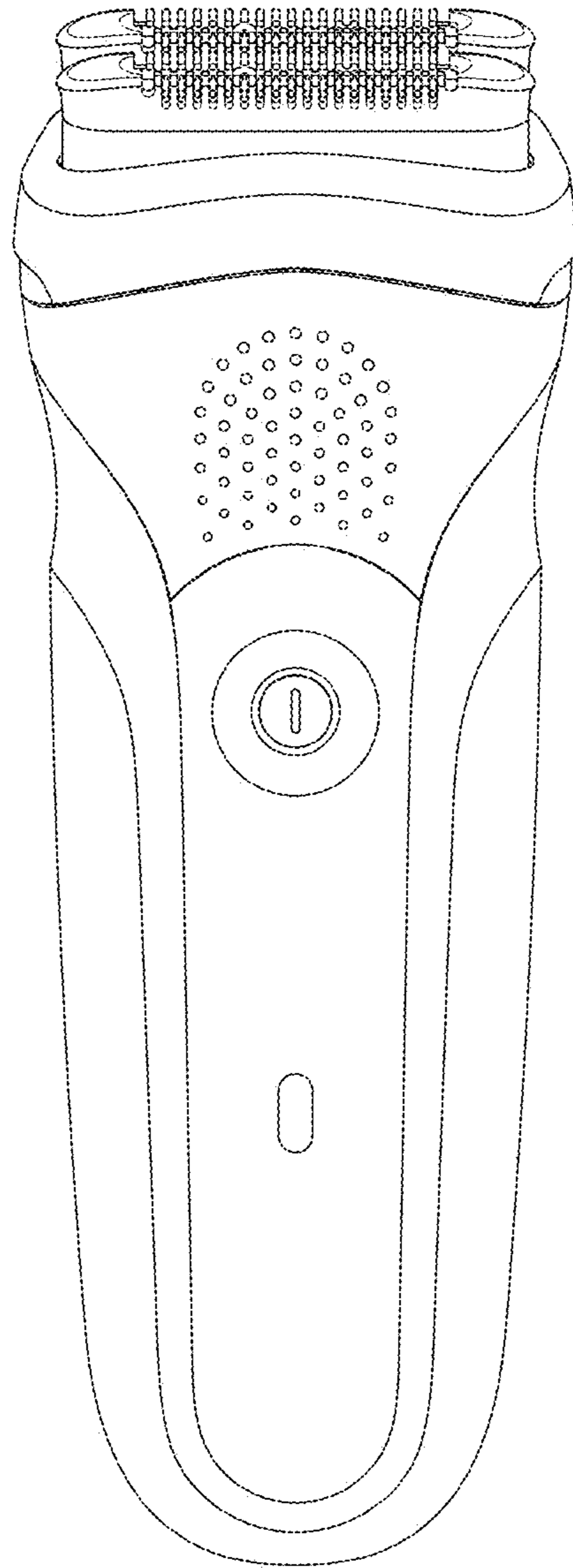

Figure 2

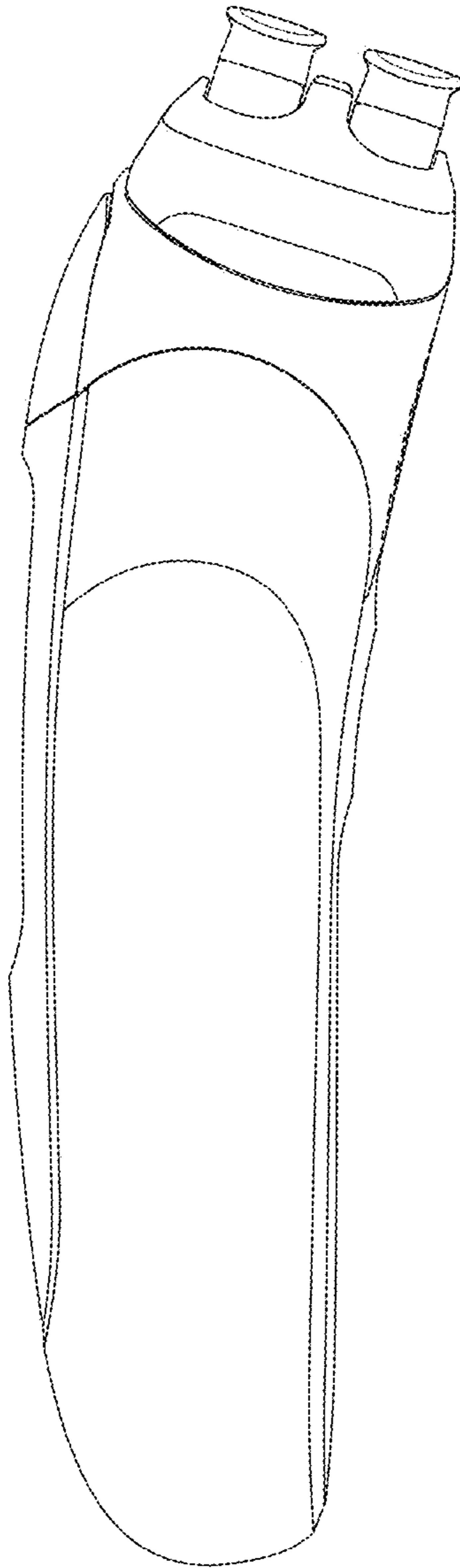

Figure 3

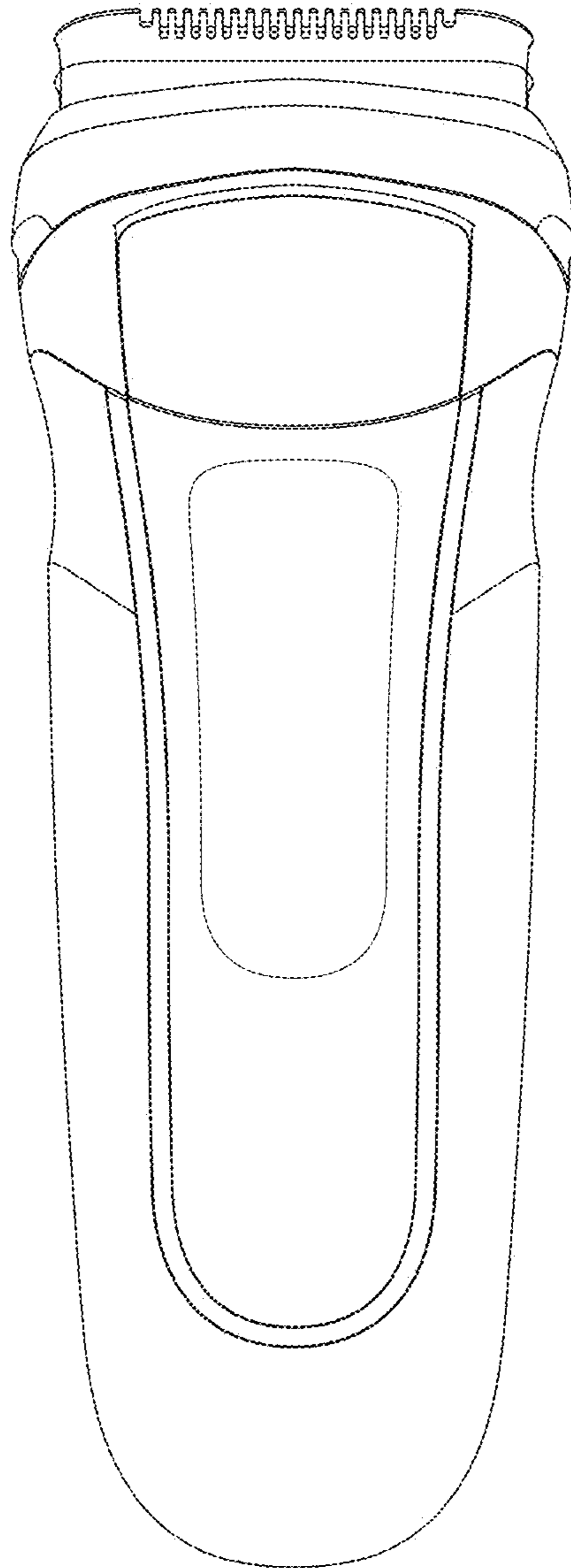

Figure 4

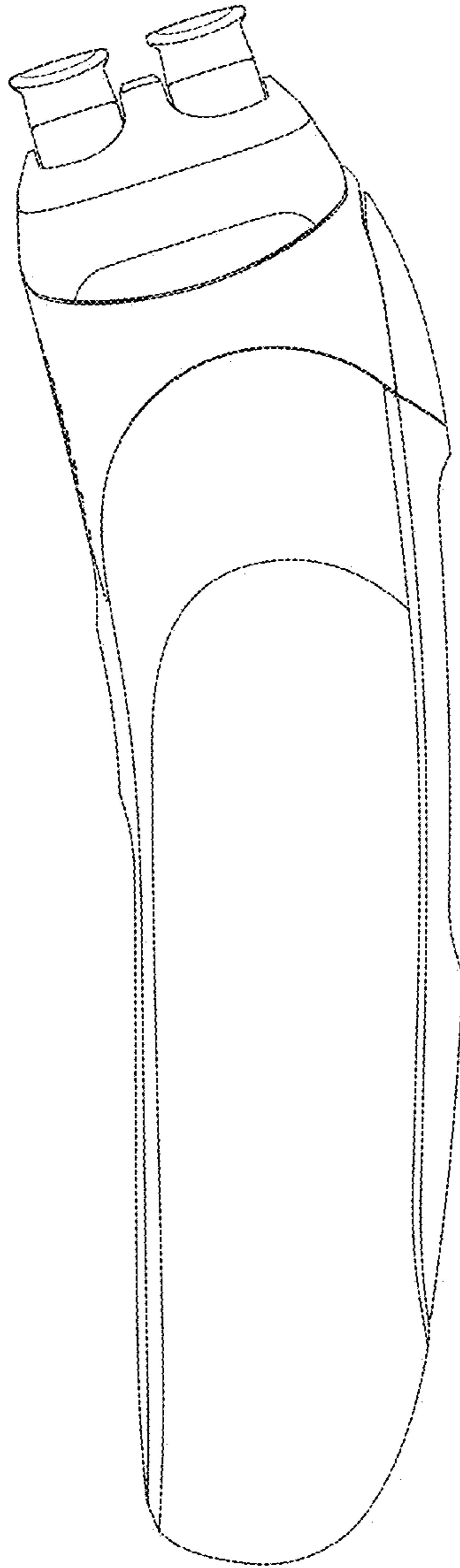

Figure 5

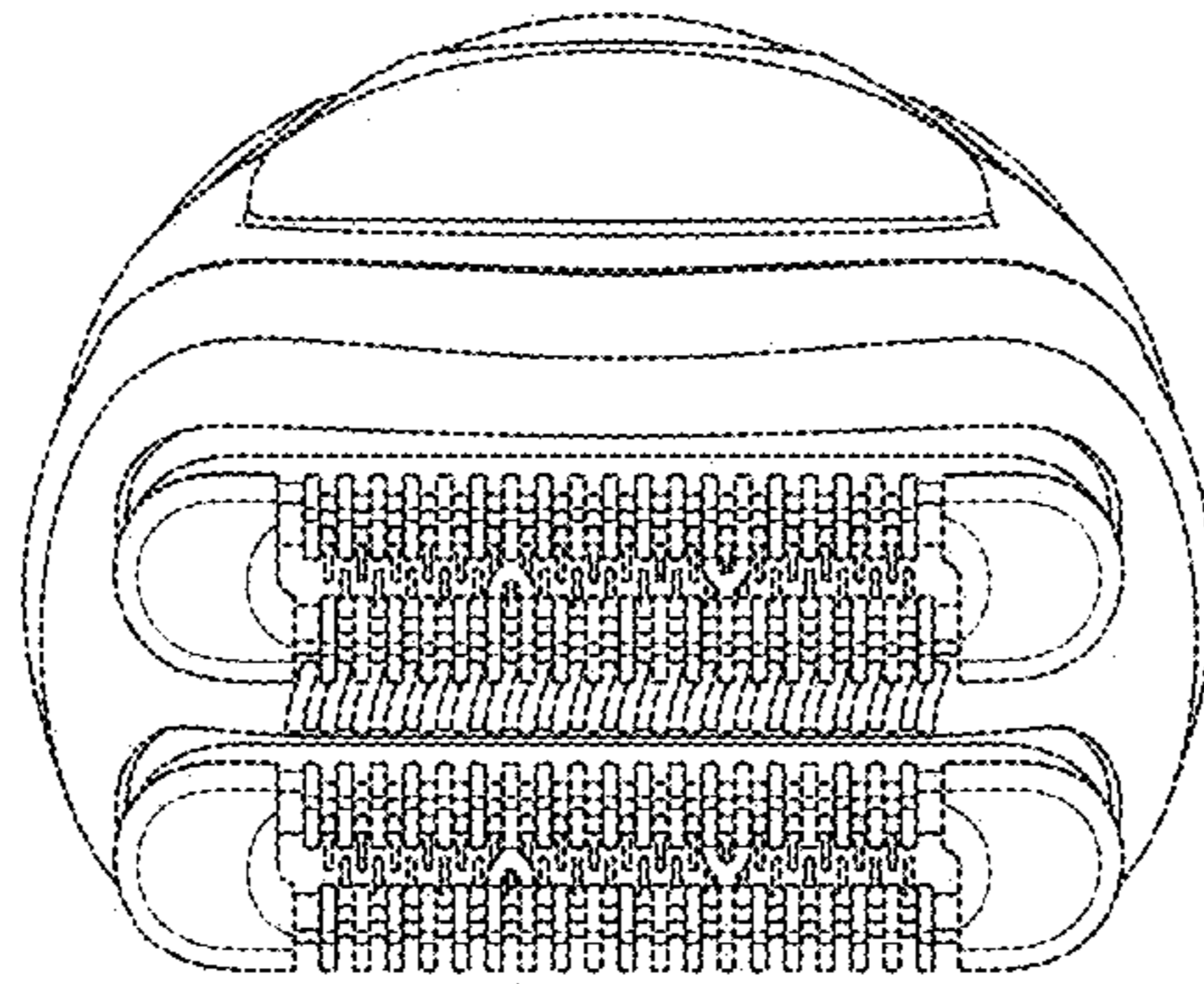

Figure 6

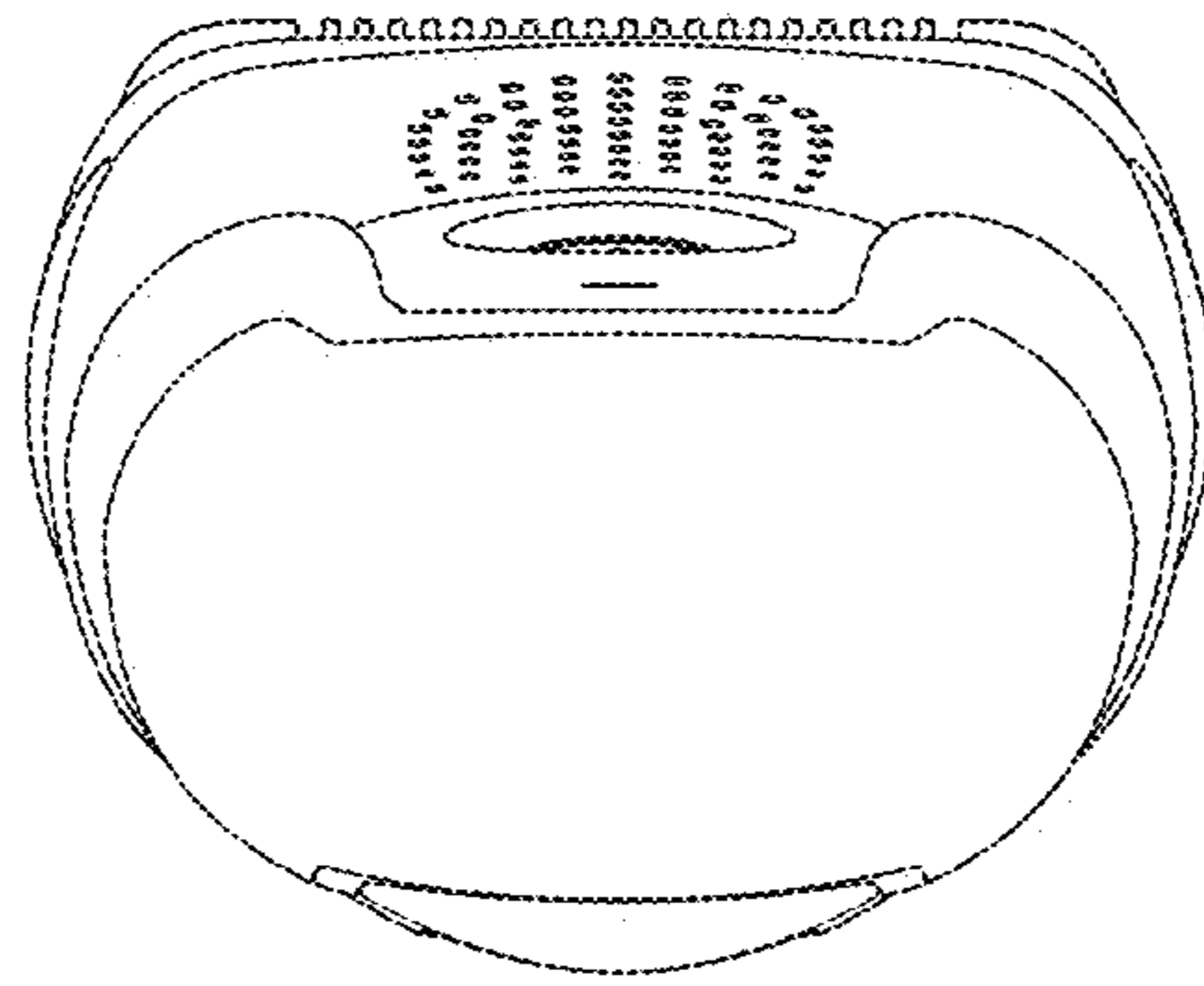

Figure 7