



US00D922511S

(12) **United States Design Patent**  
**Arnold et al.**

(10) **Patent No.: US D922,511 S**  
(45) **Date of Patent: \*\* Jun. 15, 2021**

(54) **SWING TRAINING APPARATUS**  
(71) Applicant: **Arnolds Innovations Pty Ltd.**, Dolans Bay (AU)  
(72) Inventors: **Brett Arnold**, Dolans Bay (AU); **Craig Andrews**, Dolans Bay (AU); **Mario Forster**, Dolans Bay (AU)  
(73) Assignee: **Arnolds Innovations Pty Ltd**, Dolans Bay (AU)  
(\*\*) Term: **15 Years**  
(21) Appl. No.: **29/694,955**  
(22) Filed: **Jun. 14, 2019**

3,970,316 A \* 7/1976 Westmoreland, Jr. .... A63B 69/0059  
473/212  
4,359,221 A \* 11/1982 Taylor ..... A63B 69/0046  
473/212  
4,691,924 A \* 9/1987 Strong ..... A63B 69/0059  
273/DIG. 30  
4,892,317 A \* 1/1990 Corder, Jr. .... A63B 69/0059  
473/212  
5,016,885 A \* 5/1991 Quigley ..... A63B 69/0059  
473/217  
5,096,199 A \* 3/1992 Wyatt, Jr. .... A63B 21/00069  
473/212  
5,154,416 A \* 10/1992 Smull ..... A63B 69/0059  
473/458  
5,203,567 A \* 4/1993 Erlinger ..... A63B 69/0059  
473/276  
5,295,690 A \* 3/1994 Johnson ..... A63B 69/0059  
434/252

(30) **Foreign Application Priority Data**  
Dec. 17, 2018 (AU) ..... 201817592  
(51) **LOC (13) Cl.** ..... **21-02**  
(52) **U.S. Cl.**  
USPC ..... **D21/791**  
(58) **Field of Classification Search**  
USPC ..... D21/789, 791  
CPC ..... A63B 69/3623; A63B 69/3655; A63B  
69/3688; A63B 69/0091; A63B 69/0071;  
A63B 69/3661; A63B 69/3608; A63B  
69/3667  
See application file for complete search history.

(Continued)  
*Primary Examiner* — Mitchell I. Siegel  
(74) *Attorney, Agent, or Firm* — Gardner, Linn, Burkhardt & Ondersma LLP

(56) **References Cited**  
U.S. PATENT DOCUMENTS  
1,655,092 A \* 1/1928 Davis ..... A63B 69/0059  
473/212  
2,450,162 A \* 9/1948 Promen ..... A63B 69/0059  
473/212  
3,324,851 A \* 6/1967 Posner ..... A61F 5/3723  
128/878  
3,679,214 A \* 7/1972 Boyte ..... A63B 69/0059  
473/212

(57) **CLAIM**  
The ornamental design for a swing training apparatus, as shown and described.

**DESCRIPTION**  
FIG. 1 is a rear elevation view of a swing training apparatus showing our new design;  
FIG. 2 is a bottom plan view thereof;  
FIG. 3 is a front elevation thereof;  
FIG. 4 is an exploded perspective view thereof;  
FIG. 5 is a perspective view of FIG. 1;  
FIG. 6 is a left side elevation of FIG. 1;  
FIG. 7 is a right side elevation of FIG. 1; and,  
FIG. 8 is a top plan view of FIG. 1.  
The broken lines shown on the drawings form no part of the claimed design.

**1 Claim, 3 Drawing Sheets**

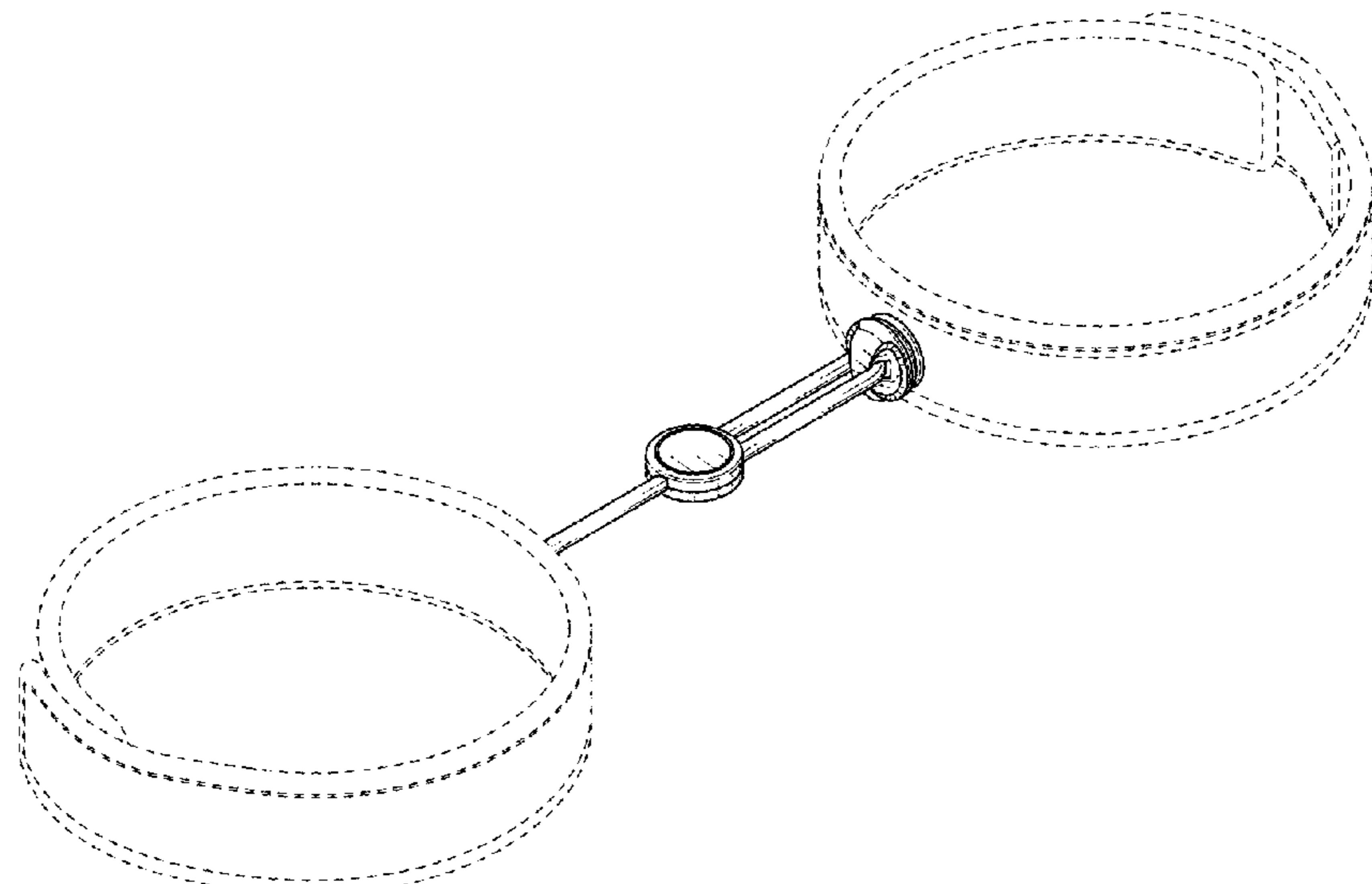

(56)

**References Cited**

U.S. PATENT DOCUMENTS

5,397,122	A *	3/1995	Herridge, II .....	A63B 21/0004 473/212
5,476,257	A *	12/1995	Bobby .....	A63B 69/0059 473/464
D372,064	S *	7/1996	del Barrio .....	D21/791
5,665,015	A *	9/1997	Clark, III .....	A63B 69/0059 473/213
5,938,548	A *	8/1999	Upshaw .....	A63B 21/0004 473/453
5,951,408	A *	9/1999	Inman .....	A63B 69/0059 273/DIG. 30
6,254,561	B1 *	7/2001	Borden .....	A61N 5/1049 128/845
6,767,290	B1 *	7/2004	Tan .....	A63B 69/0059 473/207
7,789,763	B1 *	9/2010	Smith .....	A63B 69/0059 473/214
D638,899	S *	5/2011	Quinlan .....	D21/791
D654,131	S *	2/2012	Crabtree .....	D21/791
D719,629	S *	12/2014	Beukes .....	D21/791
D782,589	S *	3/2017	Burdick .....	D21/758
D810,220	S *	2/2018	Ahn .....	D21/791
D868,918	S *	12/2019	Oyler .....	D21/791
2008/0026863	A1 *	1/2008	Eck .....	A63B 69/3623 473/212

\* cited by examiner

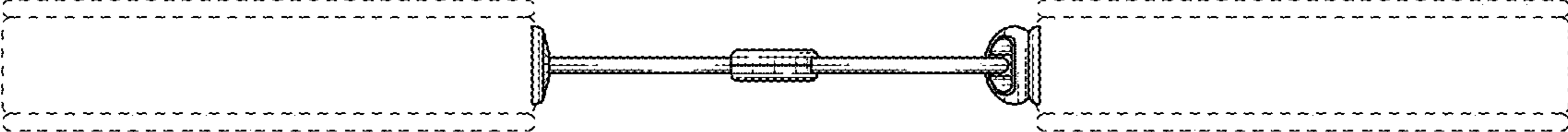

FIG. 1

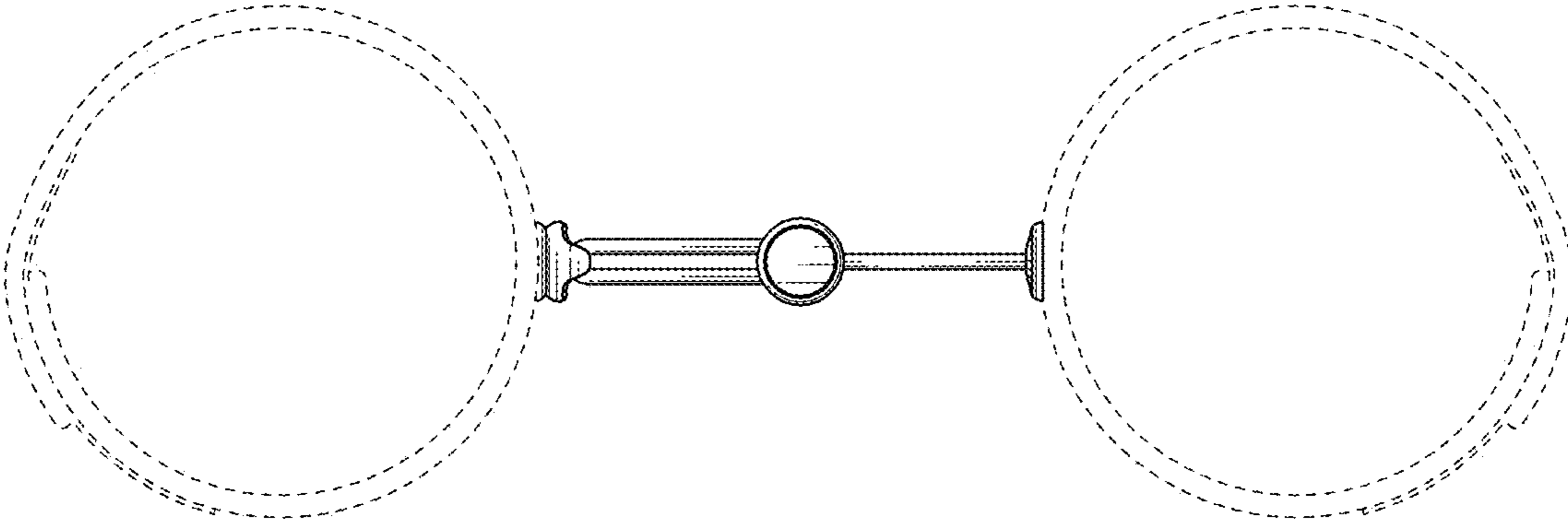

FIG. 2

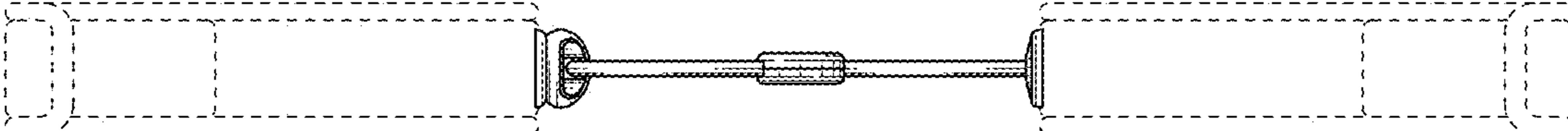

FIG. 3

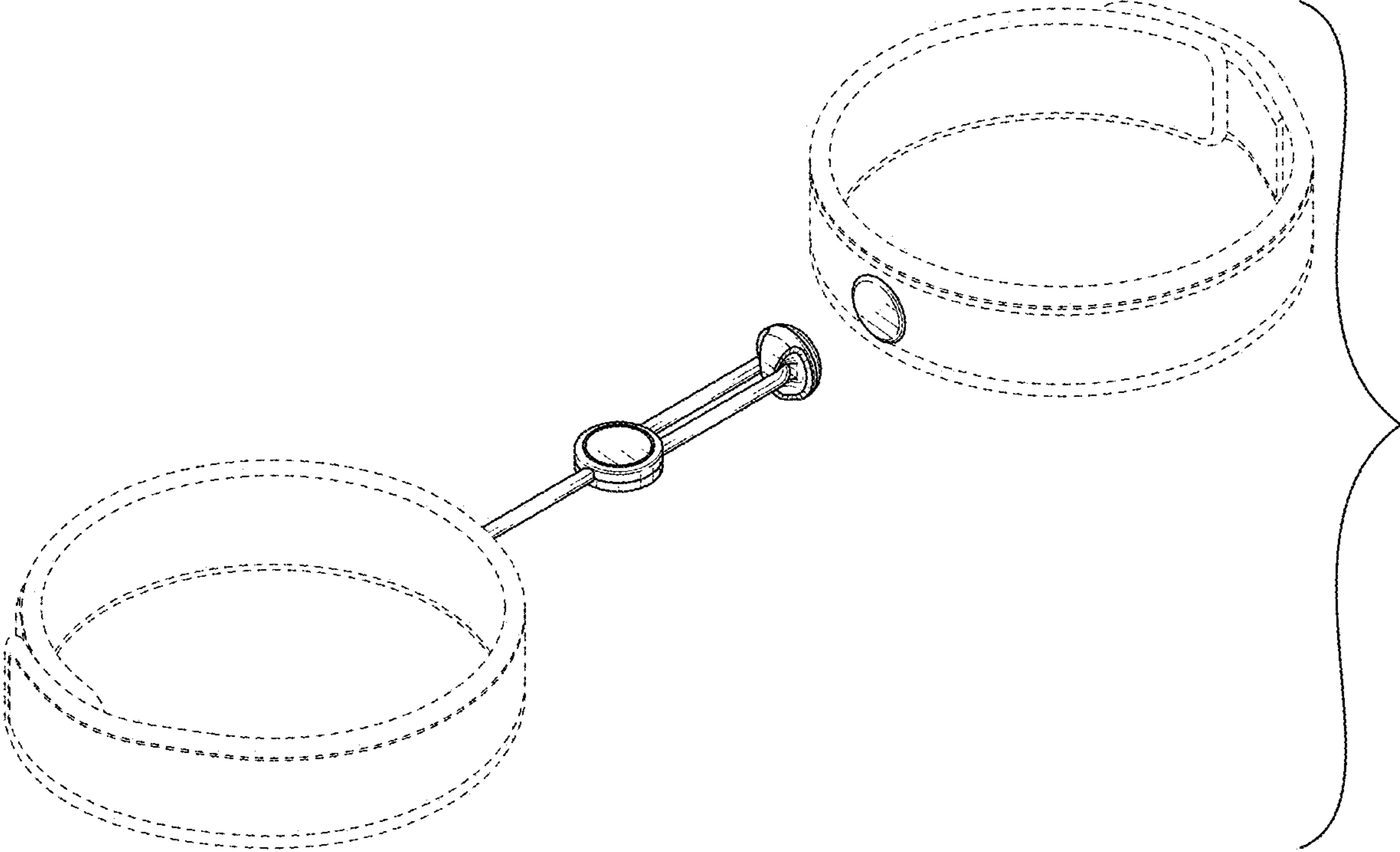

FIG. 4

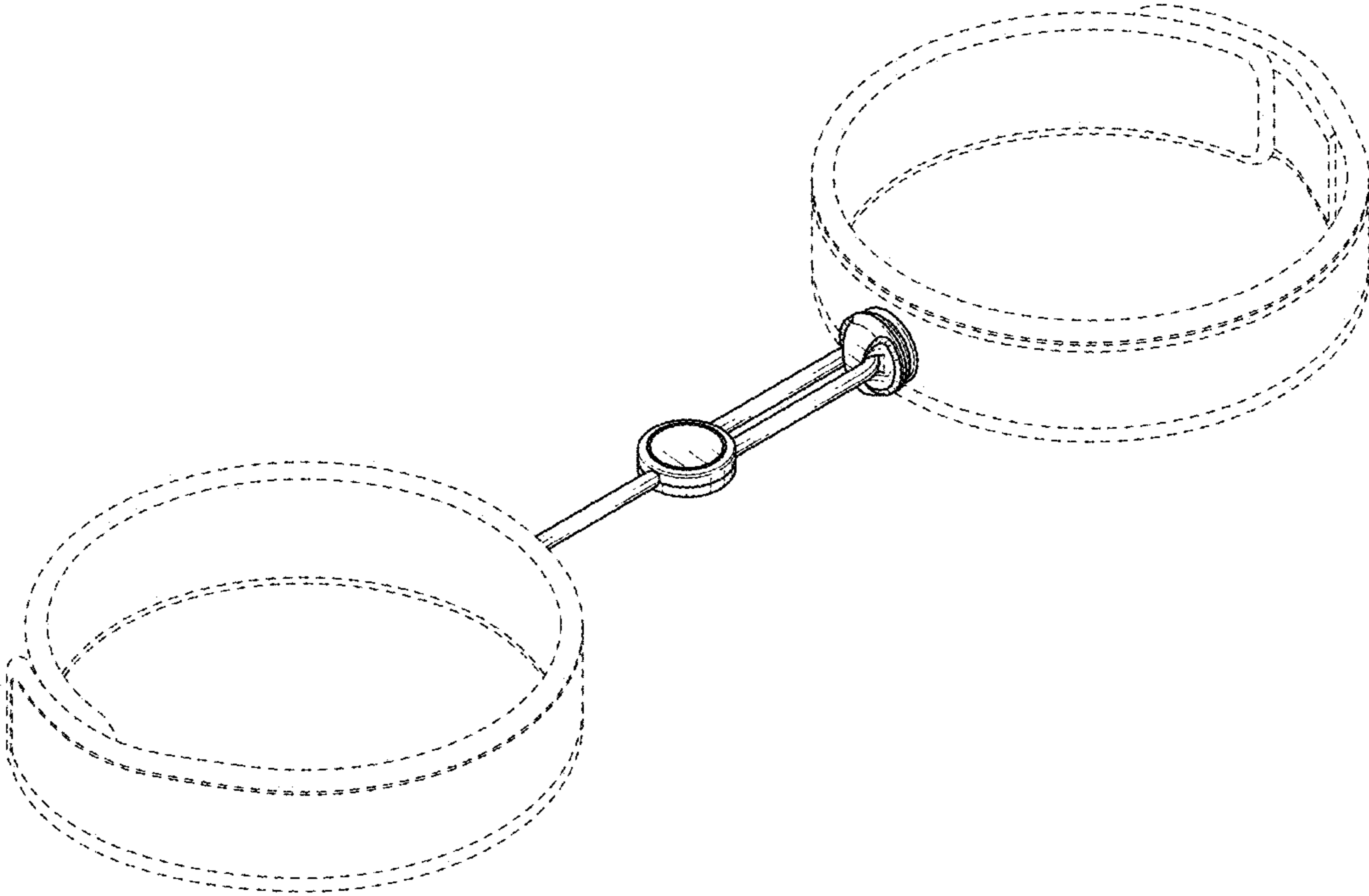

FIG. 5



FIG. 6



FIG. 7

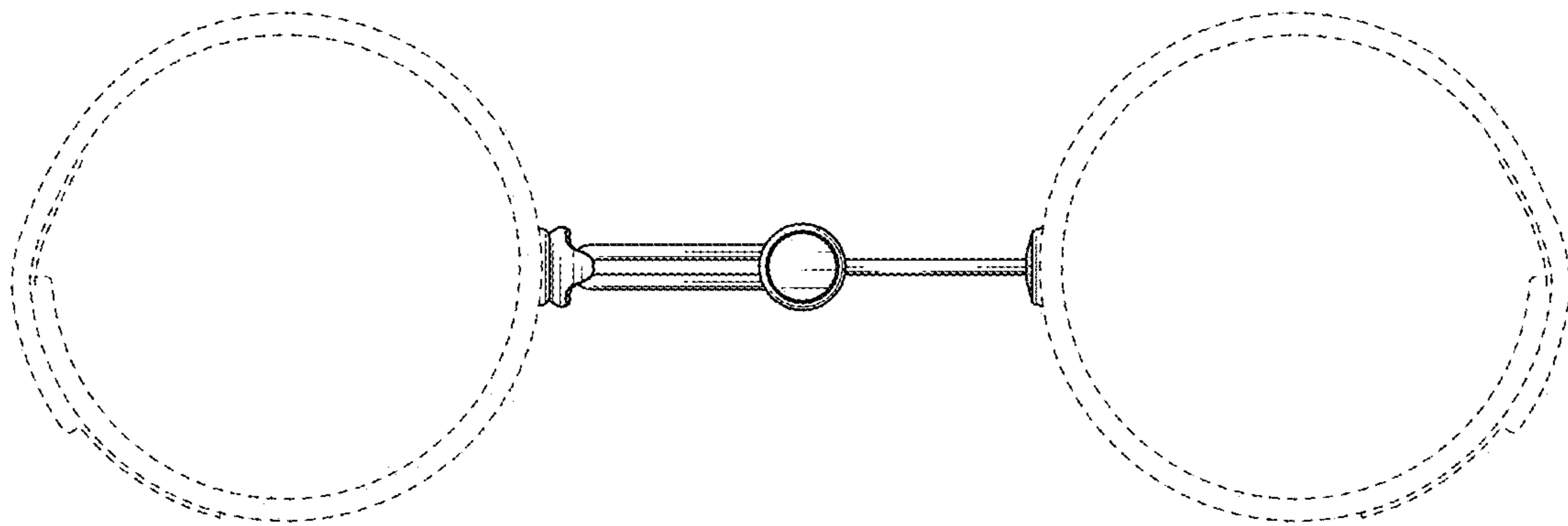

FIG. 8