



US00D922186S

(12) **United States Design Patent**  
**Schneider et al.**

(10) **Patent No.:** **US D922,186 S**

(45) **Date of Patent:** **\*\* Jun. 15, 2021**

(54) **STEP CLIP FASTENING SYSTEM**  
(71) Applicant: **Barrette Outdoor Living, Inc.**,  
Middleburg Heights, OH (US)  
(72) Inventors: **Christopher Michael Schneider**,  
Linwood, NJ (US); **Simon Rafael**  
**Marin**, Egg Harbor Township, NJ (US)  
(73) Assignee: **Barrette Outdoor Living, Inc.**,  
Middleburg Heights, OH (US)

(\*\*) Term: **15 Years**

(21) Appl. No.: **29/695,920**

(22) Filed: **Jun. 24, 2019**

(51) **LOC (13) Cl.** ..... **08-08**

(52) **U.S. Cl.**  
USPC ..... **D8/394**; D25/123

(58) **Field of Classification Search**  
USPC .... D8/394-395; D25/68, 69, 123, 125, 164,  
D25/138, 199  
CPC ..... E04C 3/00; E04C 3/06; E04C 3/07; E04C  
2003/0473; E04F 19/022; E04F 19/062;  
E04B 2/7407; E04B 2/7827; E04B  
2/7401

See application file for complete search history.

(56) **References Cited**

**U.S. PATENT DOCUMENTS**

2,003,996 A 6/1935 Finzer et al.  
2,832,102 A 4/1958 Amoroso  
D195,504 S \* 6/1963 Waite ..... D25/69  
3,197,934 A \* 8/1965 Brown ..... E04C 2/08  
52/592.4  
3,253,377 A \* 5/1966 Schakel ..... B62D 33/046  
52/592.4  
D205,891 S \* 10/1966 Feliziani ..... D25/156  
3,321,883 A 5/1967 Pascucci  
3,472,118 A 10/1969 Jureit  
D222,895 S \* 1/1972 Zampetti et al. .... D25/58  
3,807,675 A \* 4/1974 Seckerson ..... F16L 3/13  
248/73

D250,847 S \* 1/1979 Lemieux ..... D25/123  
4,209,043 A \* 6/1980 Menzel ..... B29C 53/78  
138/122  
4,226,064 A 10/1980 Kraayenhof  
5,067,677 A \* 11/1991 Miceli ..... H02G 3/26  
248/68.1  
D326,999 S \* 6/1992 Johnson ..... D8/356  
(Continued)

**FOREIGN PATENT DOCUMENTS**

FR 2989713 A1 10/2013  
KR 101907111 B1 10/2018

**OTHER PUBLICATIONS**

First Australian Examination Report dated Feb. 3, 2021 issued in connection with corresponding Australian Patent Application No. 2020203897 (5 pages total).

(Continued)

*Primary Examiner* — John Windmuller

(74) *Attorney, Agent, or Firm* — John Maldjian; Maldjian Law Group LLC

(57) **CLAIM**

The ornamental design for a step clip fastening system, as shown and described.

**DESCRIPTION**

FIG. 1 is a front, top and right side perspective view of a step clip fastening system showing my new design;  
FIG. 2 is an enlarged partial view of the front, top and right side perspective view thereof;  
FIG. 3 is a front plan view thereof;  
FIG. 4 is a left view thereof;  
FIG. 5 is an enlarged partial view of a front, right side view thereof; and,  
FIG. 6 is an enlarged partial view of a front, left side view thereof.

**1 Claim, 4 Drawing Sheets**

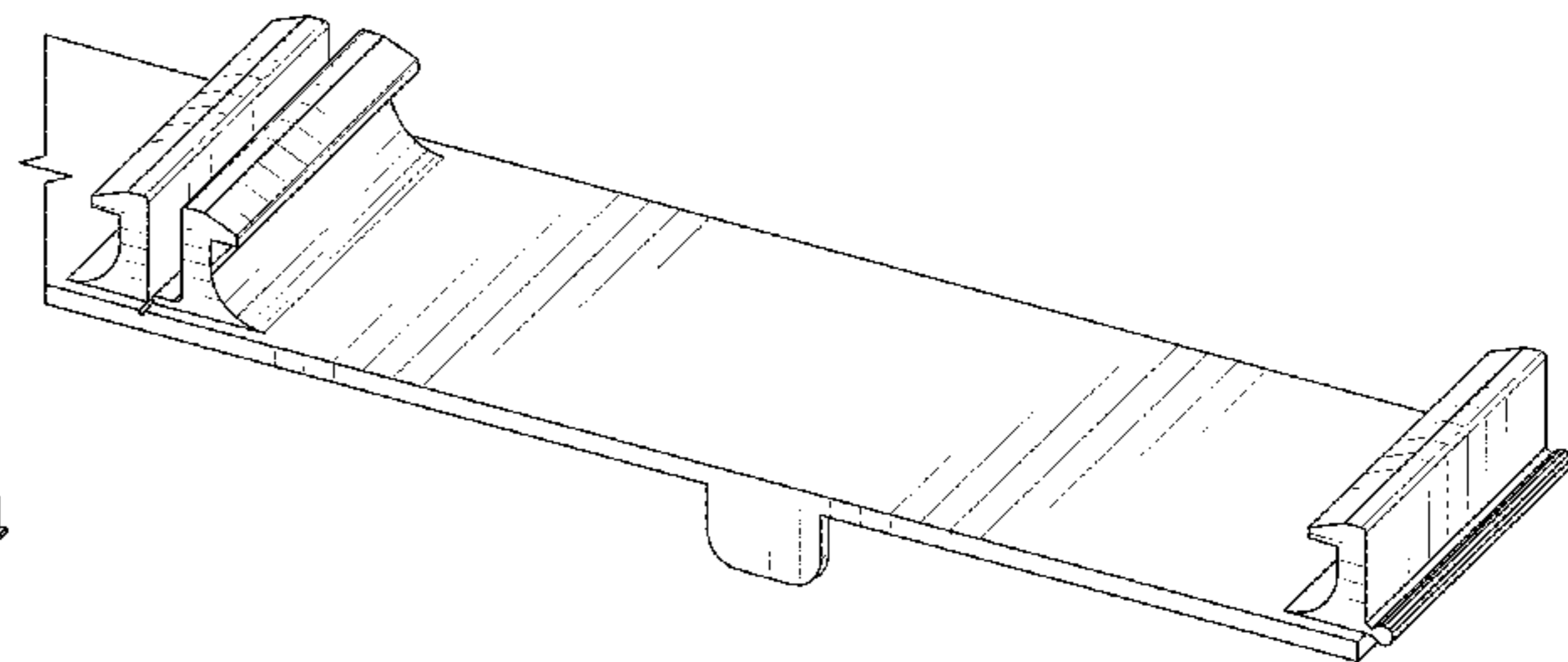
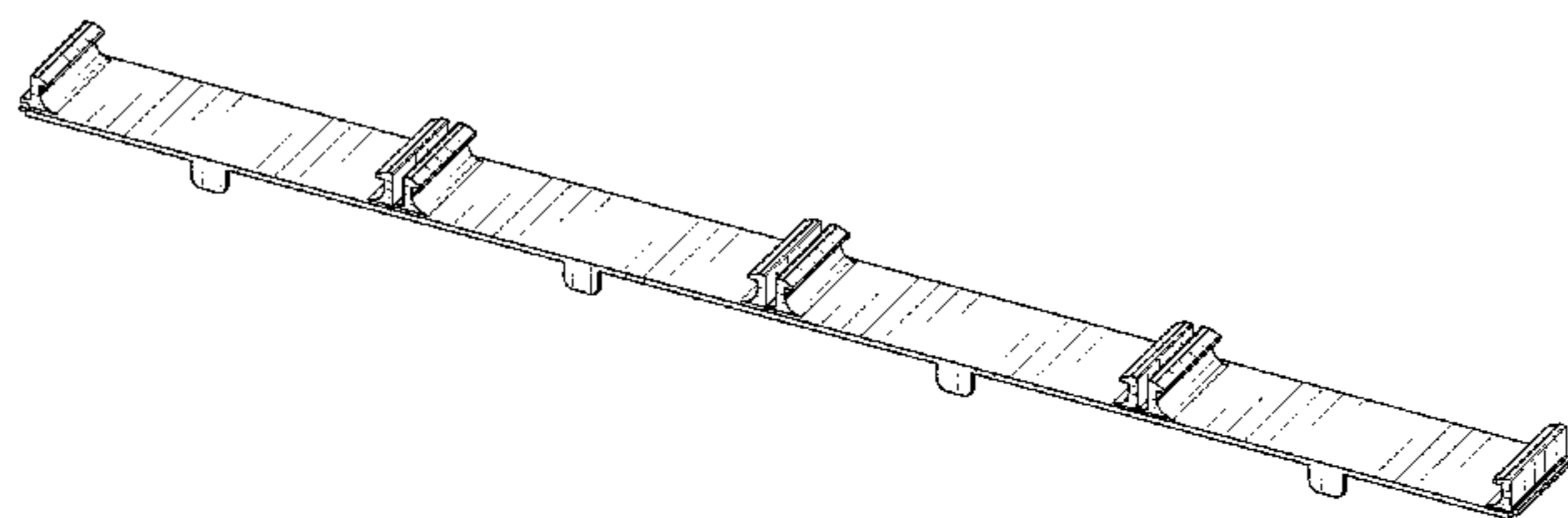

(56)

References Cited

U.S. PATENT DOCUMENTS

5,390,457 A 2/1995 Sjolander  
 D365,007 S \* 12/1995 Sheftel ..... D3/905  
 D379,427 S \* 5/1997 Laga ..... D8/373  
 5,827,441 A \* 10/1998 Solbjorg ..... F16L 3/223  
 249/91  
 D404,504 S \* 1/1999 Dickey ..... D25/125  
 D415,408 S \* 10/1999 Wizikowski, Sr. .... D8/354  
 D415,913 S \* 11/1999 Ernst ..... D6/512  
 D427,048 S \* 6/2000 Potter ..... D8/356  
 D438,650 S \* 3/2001 Neuhofer, Jr. .... D25/199  
 D462,665 S \* 9/2002 Witting ..... D13/155  
 6,694,691 B2 2/2004 Ku  
 D518,616 S \* 4/2006 Goodwin ..... D34/28  
 7,114,298 B2 10/2006 Kotler  
 D552,269 S \* 10/2007 Vibiano ..... D25/164  
 D561,102 S \* 2/2008 Taneno ..... D13/133  
 D568,254 S \* 5/2008 Patchett ..... D13/155  
 7,543,417 B2 6/2009 McIntosh et al.  
 D597,493 S \* 8/2009 Wu ..... D13/155  
 D600,366 S \* 9/2009 Boardman ..... D25/133  
 D609,373 S \* 2/2010 Curtas ..... D25/199  
 D621,076 S \* 8/2010 Vibiano ..... D25/164  
 7,793,470 B1 \* 9/2010 Mathiesen ..... E04F 15/10  
 52/177  
 7,975,728 B2 \* 7/2011 Melville ..... B29C 53/78  
 138/154  
 D656,006 S \* 3/2012 Underkofler ..... D8/394  
 8,146,303 B2 4/2012 Gibson et al.  
 8,186,116 B2 5/2012 Anderson  
 8,205,407 B2 6/2012 Genova  
 D663,045 S \* 7/2012 Ryan ..... D25/125  
 8,230,654 B2 7/2012 McIntosh et al.  
 8,266,857 B2 9/2012 David  
 D681,438 S \* 5/2013 Chen ..... D8/394  
 8,539,727 B2 9/2013 Lui  
 8,561,356 B2 10/2013 Chuang

8,973,326 B2 3/2015 Lenoci  
 D728,349 S \* 5/2015 Lake ..... D8/356  
 9,038,341 B2 5/2015 Lam et al.  
 D733,933 S \* 7/2015 Lee ..... D25/69  
 D750,282 S \* 2/2016 Lippeatt ..... D25/199  
 9,309,677 B1 4/2016 Anic  
 D755,043 S \* 5/2016 Bailey ..... D8/394  
 9,416,546 B2 8/2016 Claudin  
 9,458,635 B1 10/2016 Anic  
 9,528,277 B2 12/2016 Prati  
 9,593,490 B2 3/2017 Anic  
 D788,947 S \* 6/2017 Gilkey ..... D25/125  
 9,869,096 B2 1/2018 Brochu  
 D824,755 S \* 8/2018 Bauer ..... D8/394  
 10,472,111 B2 11/2019 Li  
 D893,289 S \* 8/2020 Oetlinger ..... D8/376  
 D893,875 S \* 8/2020 Hsieh ..... D3/313  
 10,781,595 B2 9/2020 McIntosh et al.  
 D902,023 S \* 11/2020 Briese ..... D8/394  
 D902,684 S \* 11/2020 Barraco ..... B05B 12/20  
 D8/71  
 D905,286 S \* 12/2020 Hay, III ..... D25/123  
 2003/0136070 A1 7/2003 Ku  
 2005/0034403 A1 2/2005 Chen  
 2006/0185297 A1 8/2006 Mei  
 2009/0266022 A1 10/2009 Lin  
 2010/0146900 A1 6/2010 Holland  
 2015/0059271 A1 3/2015 Tsai  
 2017/0226752 A1 8/2017 Tsai  
 2017/0298638 A1 10/2017 Bosman  
 2019/0010710 A1 1/2019 Choy  
 2020/0340256 A1 10/2020 Lee

OTHER PUBLICATIONS

First Australian Examination Report dated Mar. 17, 2021 issued in connection with corresponding Australian Patent Application No. 2020203907 (10 pages total).

\* cited by examiner

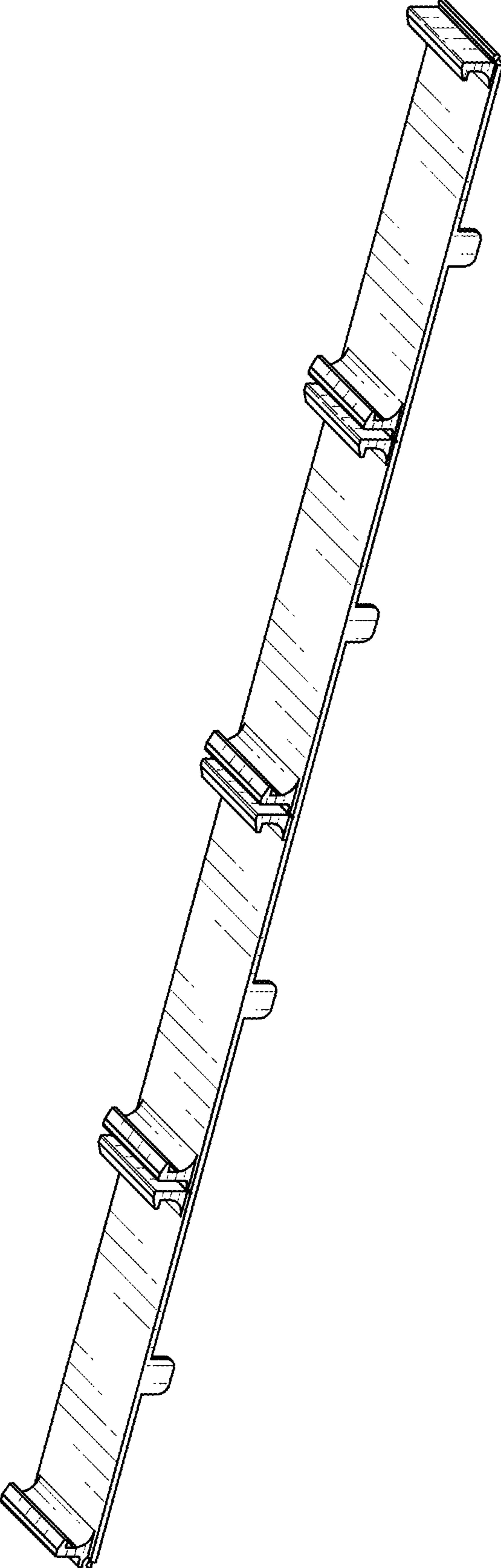

FIG. 1

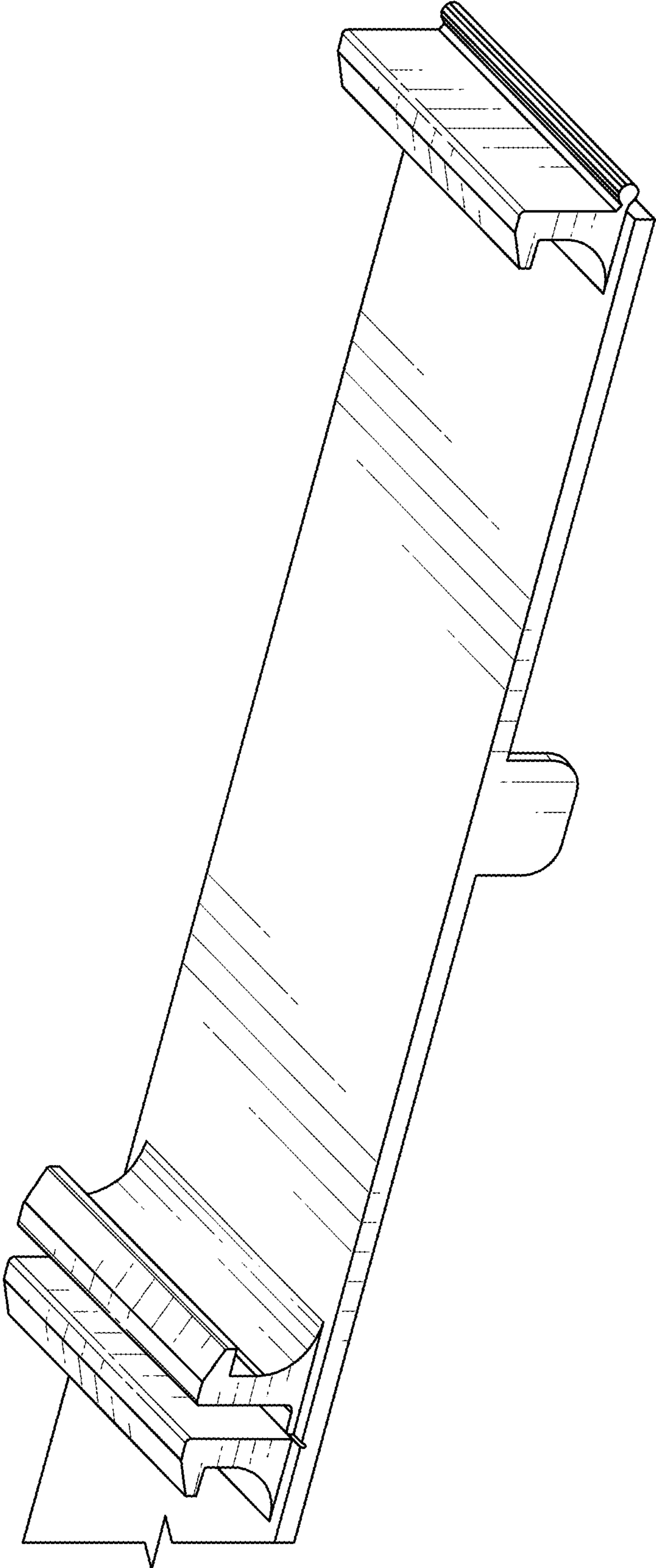

FIG. 2

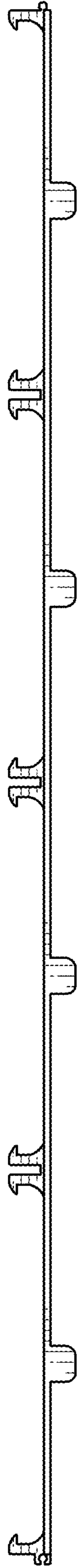

FIG. 3

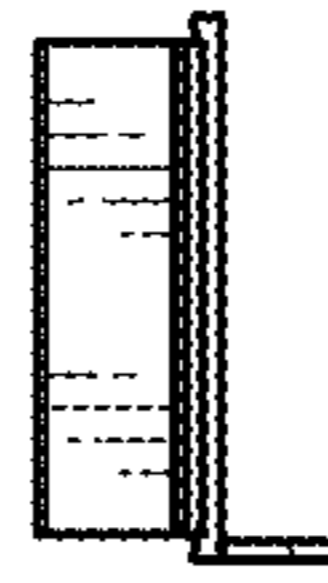

FIG. 4

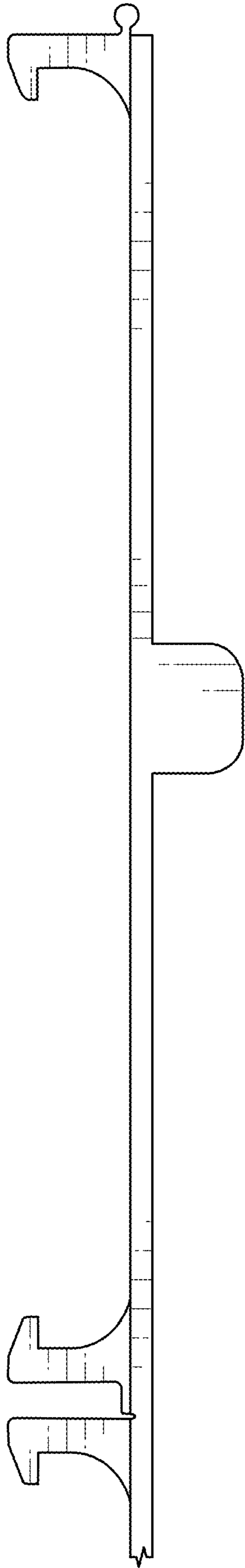

FIG. 5

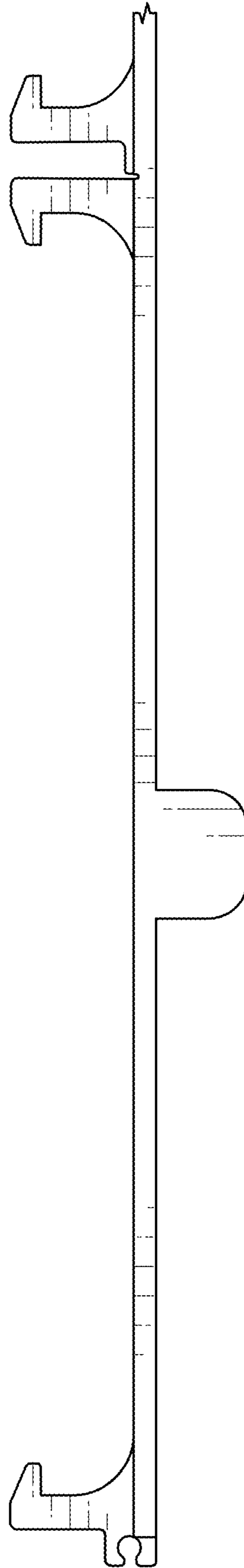

FIG. 6