



US00D921772S

(12) **United States Design Patent** (10) **Patent No.:** **US D921,772 S**  
**Hagler et al.** (45) **Date of Patent:** **\*\* \*Jun. 8, 2021**

(54) **MODEL VEHICLE ROOF SKID ASSEMBLY**

(56) **References Cited**

(71) Applicant: **Traxxas, LP**, McKinney, TX (US)

U.S. PATENT DOCUMENTS

(72) Inventors: **Skylar Hagler**, Anna, TX (US); **Otto Karl Allmendinger**, Rowlett, TX (US); **Jory Sprowl**, Honey Grove, TX (US); **Jaime Felix Barajas**, Dallas, TX (US)

3,829,117 A 8/1974 Park  
D332,978 S 2/1993 Tsuchiya  
D348,911 S 7/1994 Herrick et al.  
D411,263 S 6/1999 Korsholm  
(Continued)

(73) Assignee: **TRAXXAS LP**, McKinney, TX (US)

OTHER PUBLICATIONS

(\*) Notice: This patent is subject to a terminal disclaimer.

Traxxas Roof Skid Plate for E-Revo, 8617, Tin-Eye Date Nov. 20, 2019 [Online], [Site Visited Oct. 21, 2020] Available From Internet, URL: <[https://www.rchobbyexplosion.com/Traxxas\\_Roof\\_Skid\\_Plate\\_Next\\_Gen\\_E\\_Revo\\_p/tra8617.htm?gclid=EAlalQobChMI5PiisqHG7AIVJYFaBR00gwhOEaQYAyABEgJVWfD\\_BwE](https://www.rchobbyexplosion.com/Traxxas_Roof_Skid_Plate_Next_Gen_E_Revo_p/tra8617.htm?gclid=EAlalQobChMI5PiisqHG7AIVJYFaBR00gwhOEaQYAyABEgJVWfD_BwE)> (Year: 2019).\*

(\*\*) Term: **15 Years**

(Continued)

(21) Appl. No.: **29/708,726**

Primary Examiner — Cynthia M. Chin

(22) Filed: **Oct. 9, 2019**

(74) Attorney, Agent, or Firm — Daryl R. Wright; Gregg Carr

(51) **LOC (13) Cl.** ..... **21-01**

(57) **CLAIM**

(52) **U.S. Cl.**

USPC ..... **D21/561**; D12/406

We claim the ornamental design for a model vehicle roof skid assembly, as shown and described.

(58) **Field of Classification Search**

USPC ..... D21/424, 433, 434, 483, 495, 522, D21/533-562; D12/86-93, 98, 159, D12/163-172, 401, 400, 406; 446/431, 446/448, 454-456, 465-466, 470-471  
CPC ..... B60G 2204/128; B60G 13/003; B62D 25/00; B62D 35/00; A63H 17/262; A63H 17/00; A63H 17/395; A63H 17/38; A63H 17/26; A63H 17/28; A63H 33/042; A63H 3/16; A63H 3/50; A63H 30/00; A63H 7/04; A63H 17/36; A63H 17/264; A63H 17/004; A63H 30/04; B60R 19/02; B60R 19/023; B60R 19/18; B60R 19/24; B60R 19/44; B60R 19/48; B60R 19/56; B60R 2019/527; B60R 2019/1886

**DESCRIPTION**

FIG. 1 is an upper, left, front perspective view of a model vehicle roof skid assembly, according to our new design; FIG. 2 is front elevation view thereof; FIG. 3 is a rear elevation view thereof; FIG. 4 is a left side elevation view thereof; FIG. 5 is a right side elevation view thereof; FIG. 6 is upper plan view thereof; FIG. 7 is a lower plan view thereof; FIG. 8 is an upper, right, rear perspective view thereof; and, FIG. 9 is an upper, left, front perspective environmental use view of the model vehicle roof skid assembly.

See application file for complete search history.

(Continued)

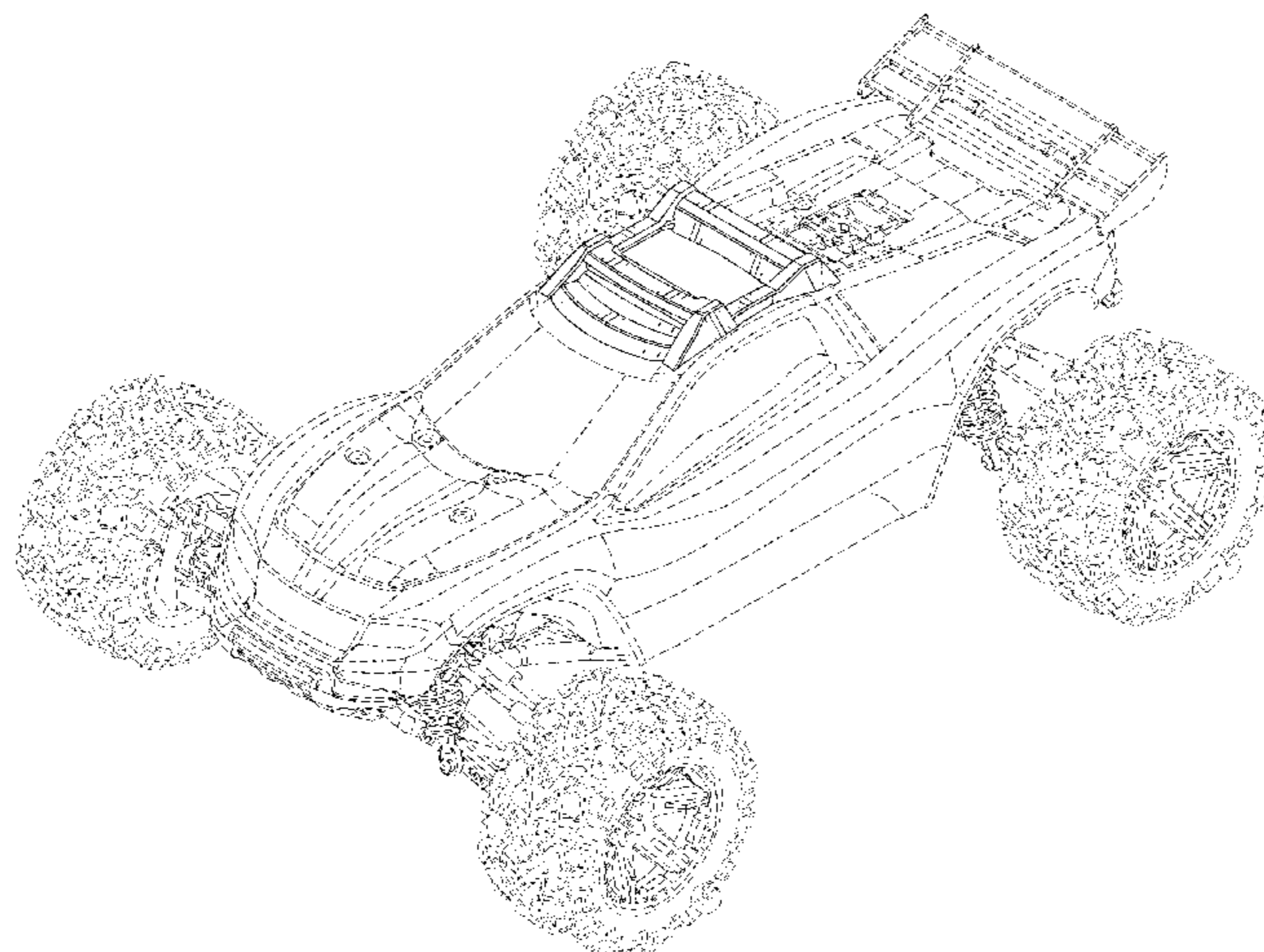

In the drawings, the broken line showing features of the model vehicle roof skid assembly form no part of the claimed design.

The broken lines in FIG. 9 depict environmental subject matter that form no part of the claimed design.

**1 Claim, 7 Drawing Sheets**

(56)

**References Cited**

U.S. PATENT DOCUMENTS

D434,364 S	11/2000	Bauer et al.
6,561,397 B1	5/2003	Bauer et al.
D493,848 S	8/2004	Dunst
D503,658 S	4/2005	Lu
D513,223 S	12/2005	Saito et al.
D521,899 S	5/2006	Walden
D523,775 S	6/2006	Walden
D523,776 S	6/2006	Walden
D556,648 S	12/2007	Nelson et al.
D564,410 S	3/2008	Lepage
D567,886 S	4/2008	Lampert et al.
D586,695 S	2/2009	Burns
D586,696 S	2/2009	Burns
D593,616 S	6/2009	Asai
D639,207 S	6/2011	Danisi
D642,090 S	7/2011	Karacabey et al.
D642,091 S	7/2011	Karacabey et al.
D642,960 S	8/2011	Berrier
D647,002 S	10/2011	Mullen
D651,133 S	12/2011	Liebl
D655,236 S	3/2012	Sanschagrín
D655,668 S	3/2012	Levorato et al.
D678,173 S	3/2013	McIntire
D681,542 S	5/2013	Oliver
D686,136 S	7/2013	Galley
D690,256 S	9/2013	Ewringmann
D691,523 S	10/2013	Waugh et al.
D728,450 S	5/2015	Yen
D730,806 S	6/2015	Lim
9,150,159 B1	10/2015	Meszaros et al.
D758,281 S	6/2016	Galloway
D761,713 S	7/2016	Hensley
D764,972 S	8/2016	Gonzalez
D766,157 S	9/2016	Reynolds et al.
D772,783 S	11/2016	Schleef
D776,601 S	1/2017	McDonald, II et al.
D777,619 S	1/2017	Barajas et al.
D778,784 S	2/2017	Hirooka
D781,207 S	3/2017	Johnson
D783,502 S	4/2017	Hensley
D783,503 S	4/2017	Hensley
D783,726 S	4/2017	Williams et al.
D793,328 S	8/2017	Bridges
D803,141 S	11/2017	Peat
D810,148 S	2/2018	Loew et al.

D815,581 S	4/2018	Anderson et al.
D816,009 S	4/2018	Reynolds et al.
D816,011 S	4/2018	Garcia
D820,736 S	6/2018	Vaarsi
D822,126 S	7/2018	Allmendinger et al.
D826,831 S	8/2018	Eck et al.
D827,054 S	8/2018	Ewing et al.
D828,796 S	9/2018	Allmendinger et al.
D829,831 S	10/2018	Redlin et al.
D833,366 S	11/2018	Dowdey
D836,501 S	12/2018	Mori
D837,307 S	1/2019	Jin
D839,363 S	1/2019	Ewing et al.
D847,724 S *	5/2019	Sprowl ..... D12/401
D856,262 S	8/2019	Marankie
D856,432 S	8/2019	Ewing et al.
D862,610 S *	10/2019	Barajas ..... D21/548
D864,310 S *	10/2019	Jens Christensen ..... D21/562
D864,840 S	10/2019	Wood
D865,079 S	10/2019	Ewing
D866,448 S	11/2019	Ash
D867,474 S	11/2019	Ewing et al.
D867,475 S	11/2019	Ewing et al.
D867,476 S	11/2019	Wood et al.
D870,615 S	12/2019	Wood
D876,555 S	2/2020	Barajas et al.
D885,302 S *	5/2020	Sprowl ..... D12/401
D891,356 S *	7/2020	Sprowl ..... D12/401
D897,930 S *	10/2020	MacIndoe ..... D12/401
2006/0151554 A1 *	7/2006	Bulski ..... B60R 9/055 224/328
2012/0125961 A1 *	5/2012	Gobart ..... B60R 9/045 224/321
2014/0067215 A1	3/2014	Wetterlund et al.
2017/0120836 A1 *	5/2017	Calvin ..... B60J 7/106
2019/0375337 A1	12/2019	Gauci

OTHER PUBLICATIONS

Pre-Cut Brute Clear Body, Earliest Available Date Oct. 21, 2020 [Online], [Site Visited Oct. 21, 2020] Available From Internet, URL: <<https://www.prolineracing.com/bodies/pre-cut-brute-clear-body-e-revo2.asp>> (Year: 2020).\*

Traxxas 8917 Skid Plate, Roof (Body) (Black)/ 3x10mm Cs (4), Earliest Available Date Sep. 8, 2020 [Online], [Site Visited Oct. 21, 2020] Available From Internet, URL in PDF (Year: 2020).\*

E-REVO Data, Traxxas.com, [online], [site visited Jun. 3, 2020]. <URL: <https://traxxas.com/products/landing/e-revo/>> (Year: 2020).

Maxx Data, Traxxas.com, [online], [site visited Jun. 3, 2020]. <URL: <https://traxxas.com/products/landing/maxx/>> (Year: 2020).

Rustler 4x4 VXL Data, Traxxas.com, [online], [site visited Jun. 3, 2020]. <URL: <https://traxxas.com/products/landing/rustler-4x4-vxl/>> (Year: 2020).

Polaris Molded UTV Roof 1/Cargo Tray (16-20 Ranger 1000 & 1000XP/ 13-20 Ranger 900XP), RoughCountry.com, [online], [site visited Jun. 3, 2020]. <URL: <https://www.roughcountry.com/polaris-ranger-molded-utv-roof-79313202.html>> (Year: 2020).

\* cited by examiner



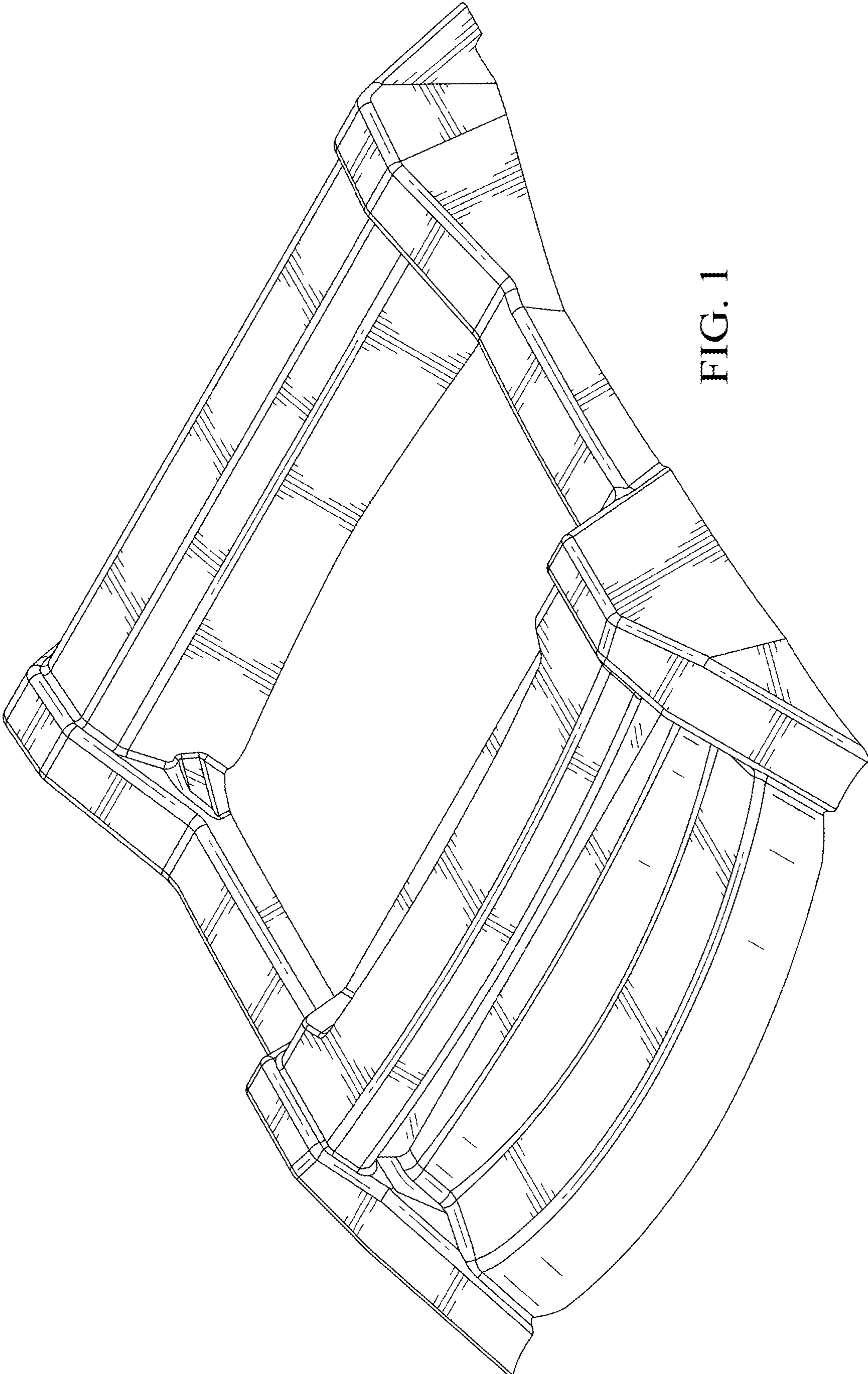

FIG. 1

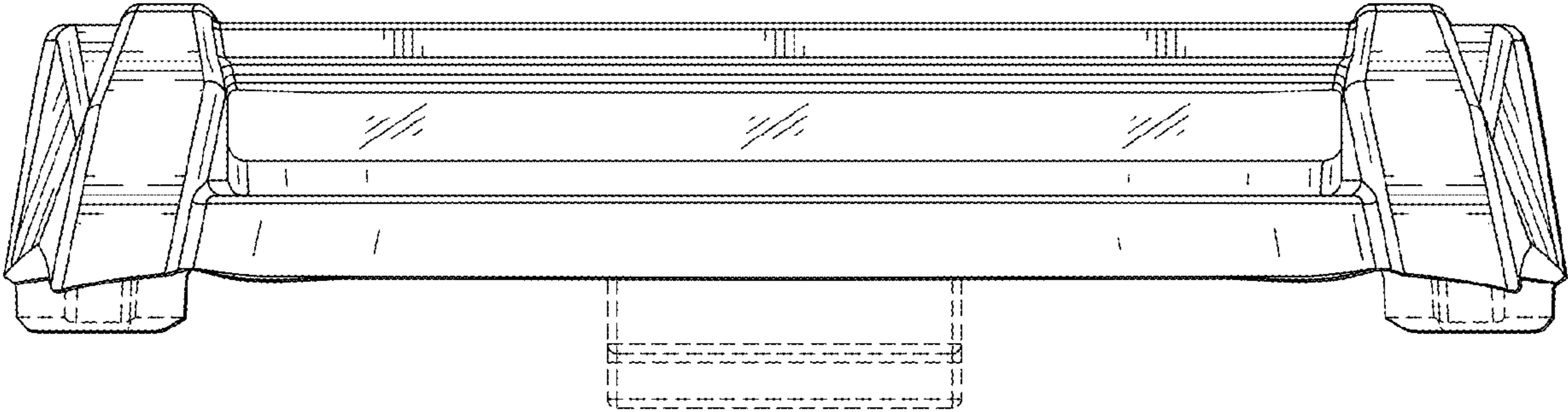

FIG. 2

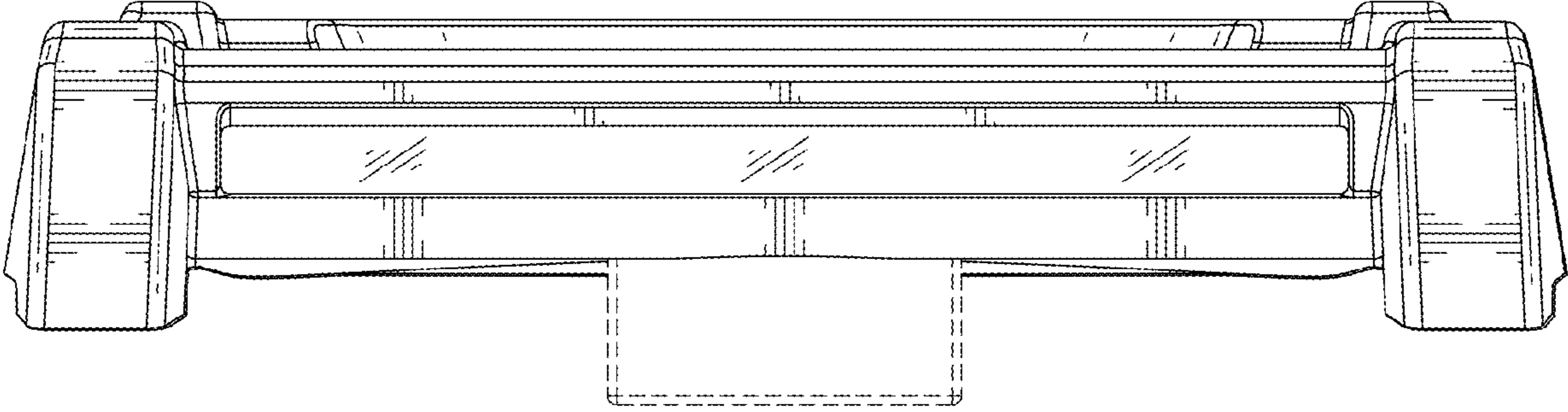

FIG. 3

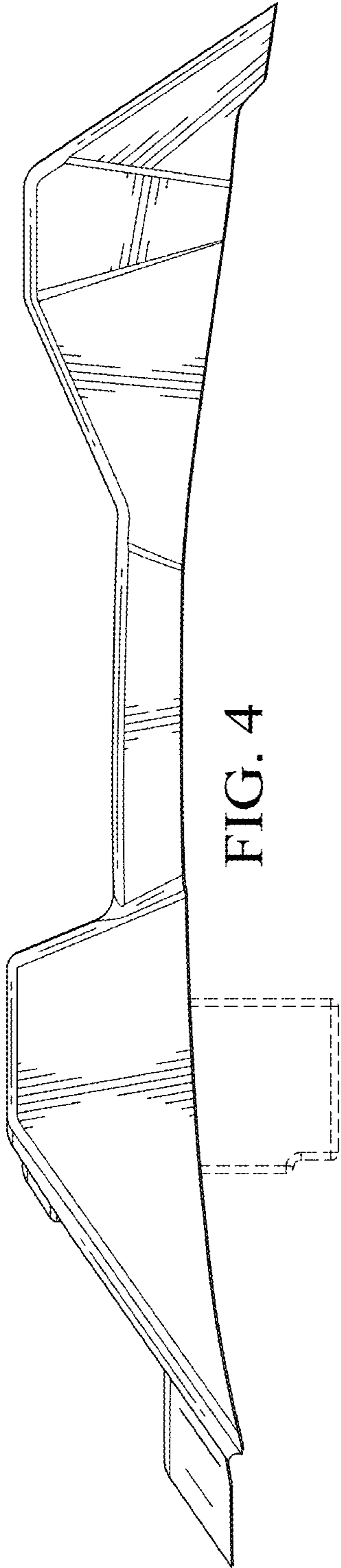

FIG. 4

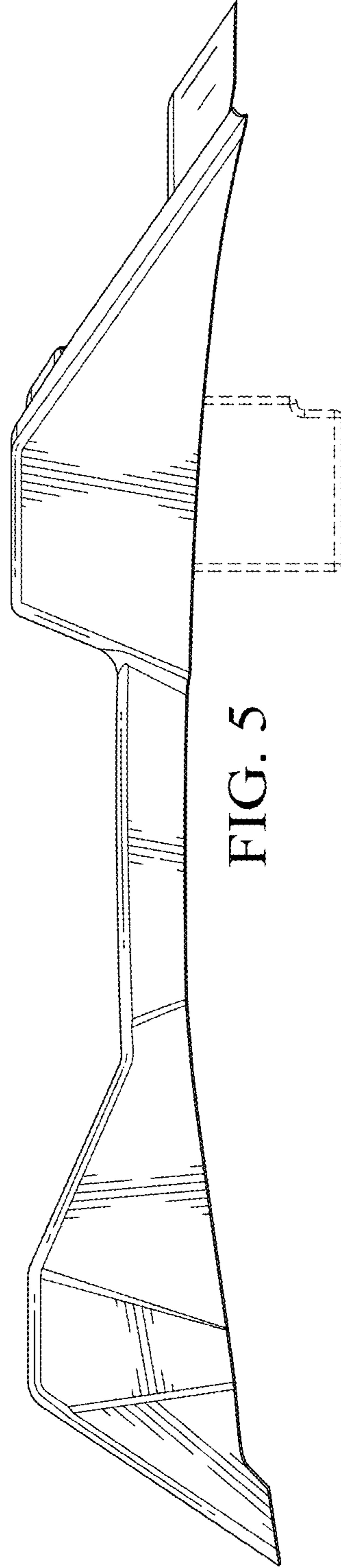

FIG. 5

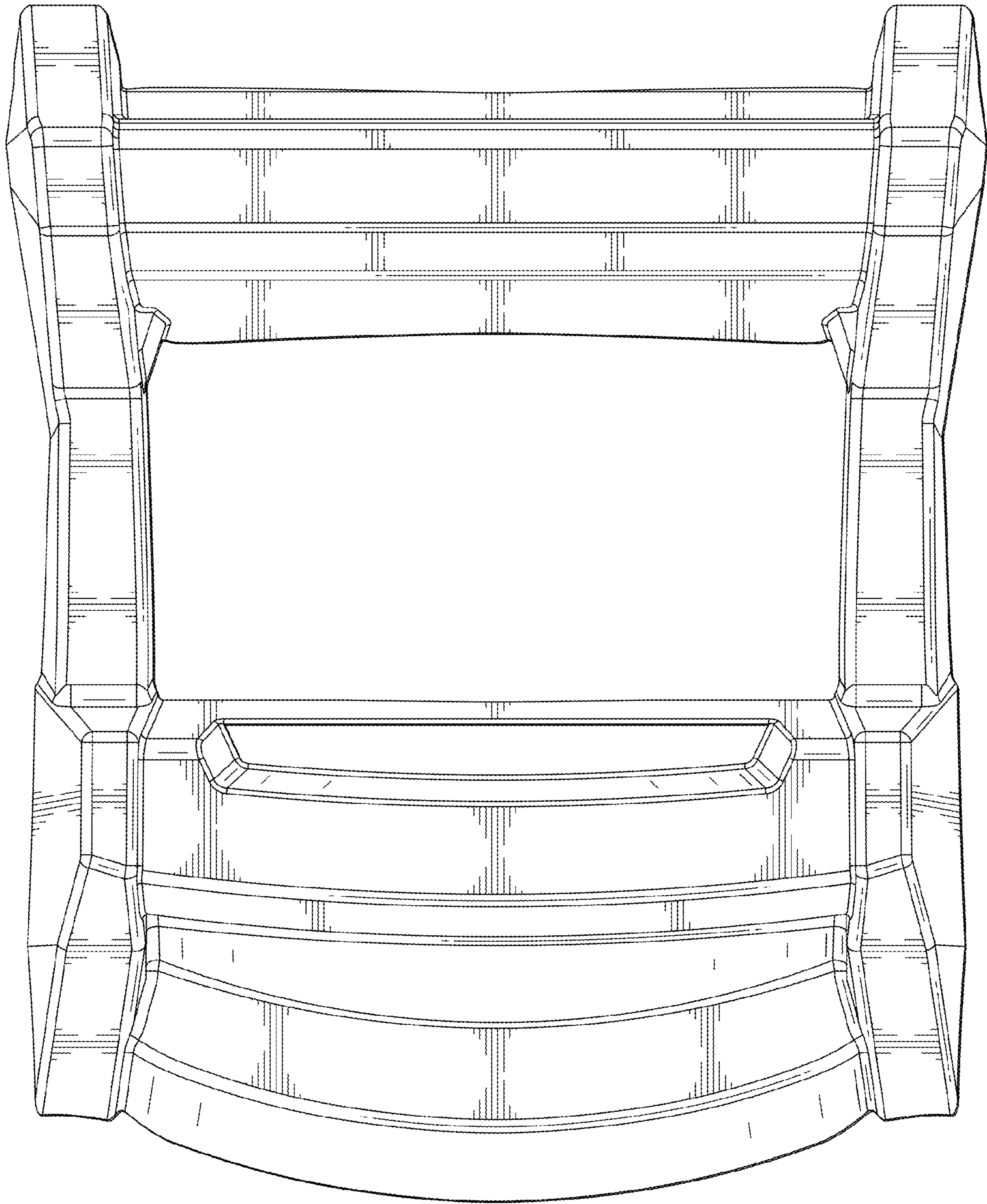

FIG. 6



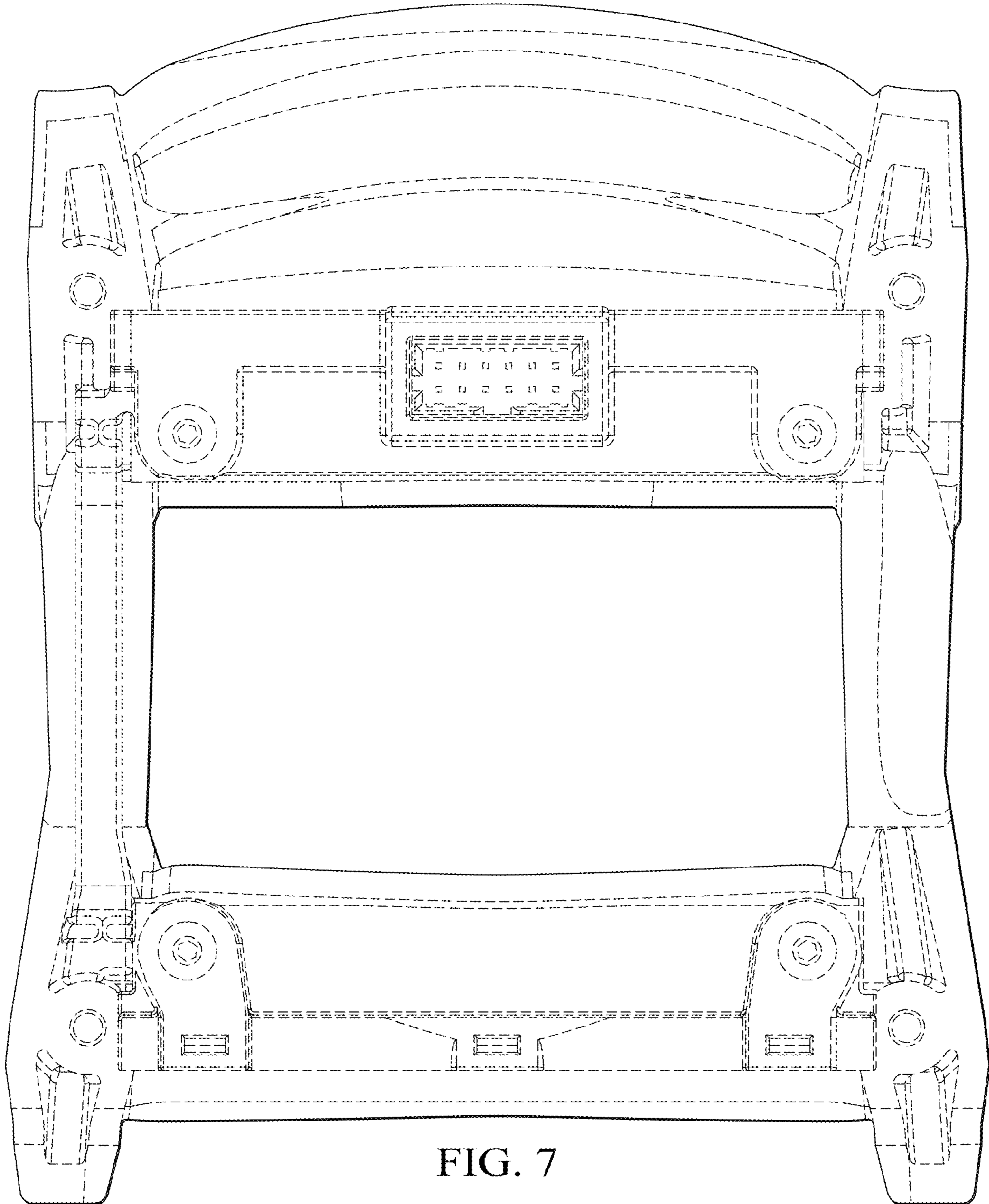

FIG. 7

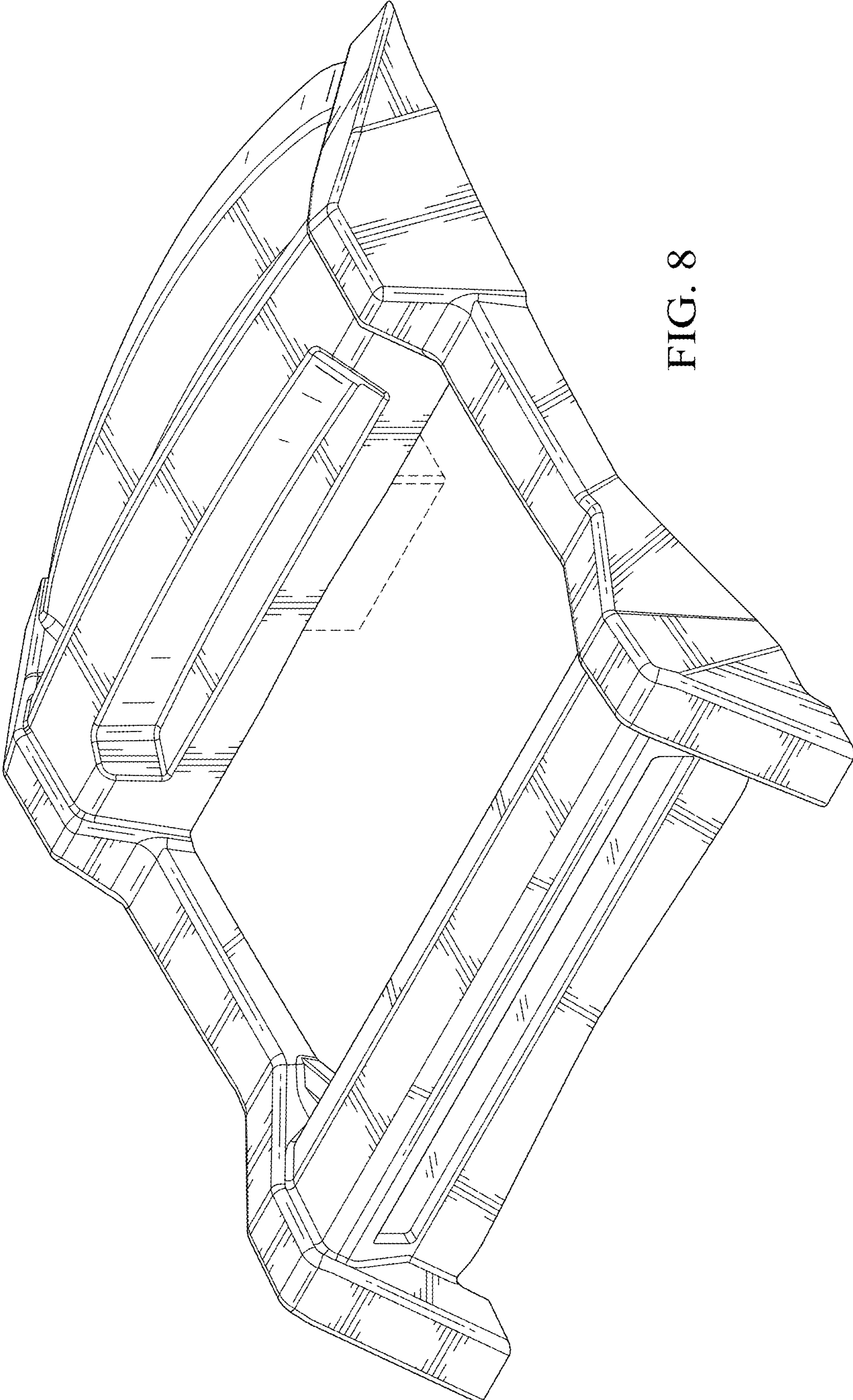

FIG. 8



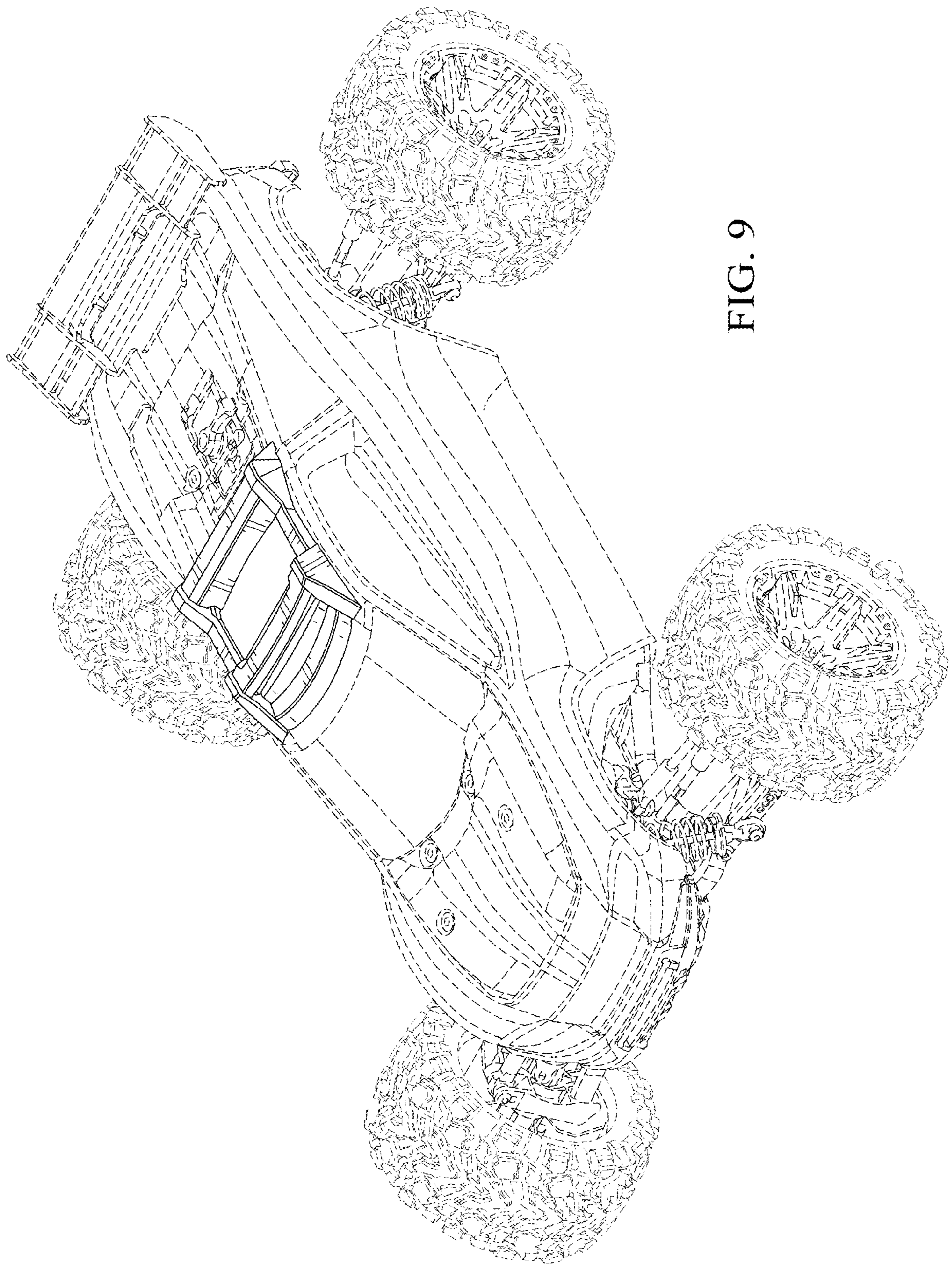

FIG. 9