



US00D921716S

(12) **United States Design Patent**
Lee et al.

(10) **Patent No.:** **US D921,716 S**
(45) **Date of Patent:** **** Jun. 8, 2021**

(54) **REFRIGERATOR**

(71) Applicant: **SAMSUNG ELECTRONICS CO., LTD.**, Suwon-si (KR)

(72) Inventors: **Choong-Eun Lee**, Suwon-si (KR);
Seon-Ju Lee, Suwon-si (KR)

(73) Assignee: **SAMSUNG ELECTRONICS CO., LTD.**, Gyeonggi-do (KR)

(**) Term: **15 Years**

(21) Appl. No.: **29/724,438**

(22) Filed: **Feb. 14, 2020**

(30) **Foreign Application Priority Data**

Sep. 16, 2019 (KR) 30-2019-0044353

(51) **LOC (13) Cl.** **15-07**

(52) **U.S. Cl.**
USPC **D15/89**

(58) **Field of Classification Search**
USPC D15/79, 80, 81, 82, 83, 84, 85, 86, 87,
D15/88, 89, 90, 91; D8/315, 323, 327,
D8/328, 329; D7/402
CPC F25C 2400/10; F25D 2400/10; F25D
2400/12; F25D 2400/14; F25D 2400/18;
G05B 2219/2654; G09F 23/0058; Y10S
292/71
See application file for complete search history.

(56) **References Cited**

U.S. PATENT DOCUMENTS

D561,787 S * 2/2008 Choi D15/89
D612,677 S * 3/2010 Jeon D7/402
D712,441 S * 9/2014 Kim D15/89
D718,574 S * 12/2014 Nordwall D7/402
D718,605 S * 12/2014 Yang D8/315

D745,577 S * 12/2015 Kim D15/89
D745,579 S * 12/2015 Kim D15/89
D763,654 S * 8/2016 Chung D8/315
D781,933 S 3/2017 Shrader et al.
D820,887 S * 6/2018 Lee D15/88
D826,294 S * 8/2018 Kim D15/89
D826,686 S * 8/2018 Kim D8/315
D831,709 S * 10/2018 Kim D15/89
D849,503 S * 5/2019 Lee D8/315
D900,586 S * 11/2020 Pille D8/315

FOREIGN PATENT DOCUMENTS

CN 304721407 7/2018
CN 304891498 11/2018
CN 304946208 12/2018
KR 300855717 5/2016

* cited by examiner

Primary Examiner — Mojtaba Tehrani

(74) *Attorney, Agent, or Firm* — Cantor Colburn LLP

(57) **CLAIM**

The ornamental design for a refrigerator, as shown and described.

DESCRIPTION

FIG. 1 is a front perspective view of a refrigerator, showing our new design;
FIG. 2 is a front view thereof;
FIG. 3 is a rear view thereof;
FIG. 4 is a left-side view thereof;
FIG. 5 is a right-side view thereof;
FIG. 6 is a top view thereof;
FIG. 7 is a bottom view thereof; and,
FIG. 8 is an enlarged view of the portion 8 in FIG. 1.
The even-dash broken lines illustrating portions of the refrigerator form no part of the claimed design. The dot-dash broken lines encircling enlargement portions of the refrigerator form no part of the claimed design.

1 Claim, 8 Drawing Sheets

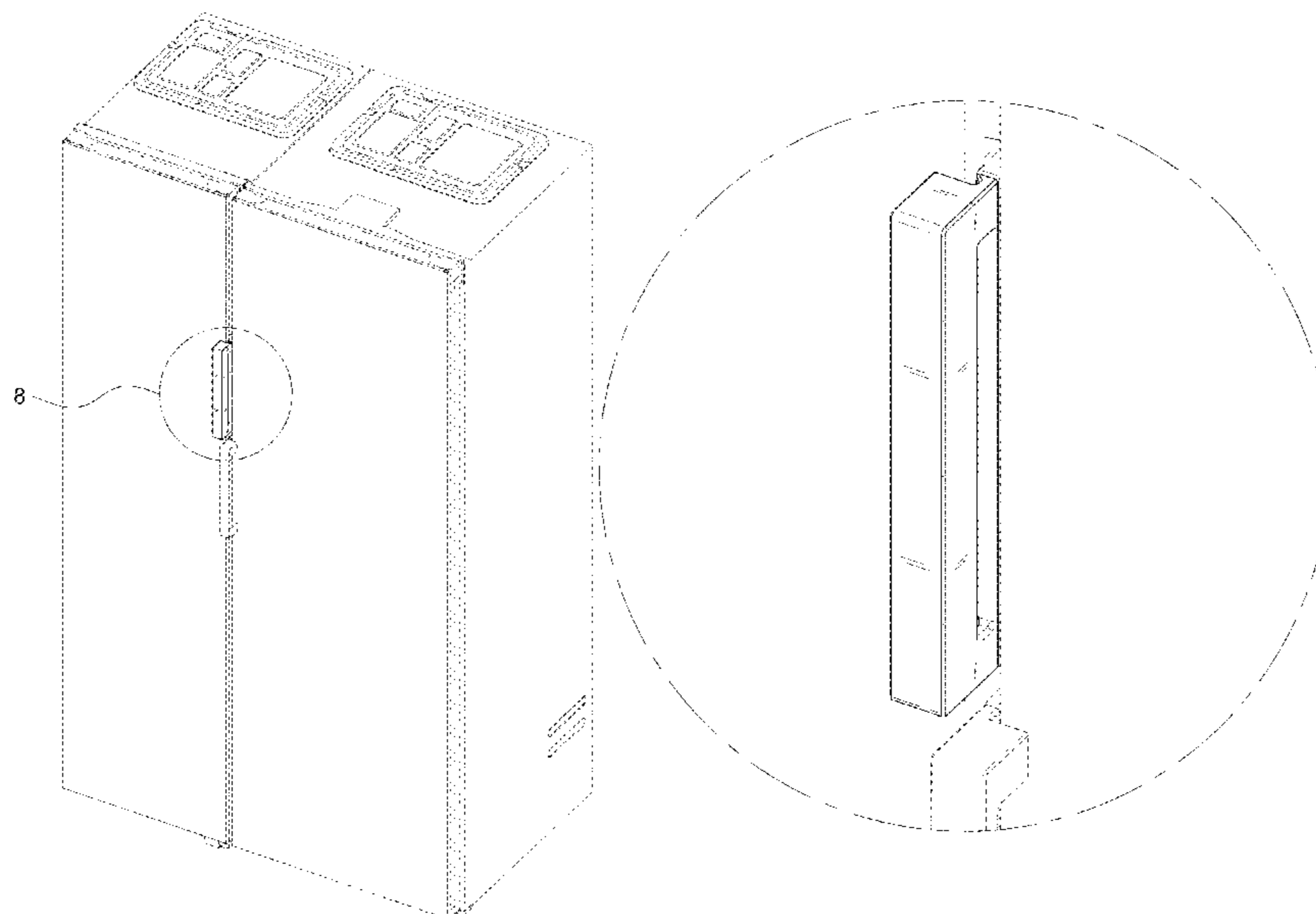

FIG. 1

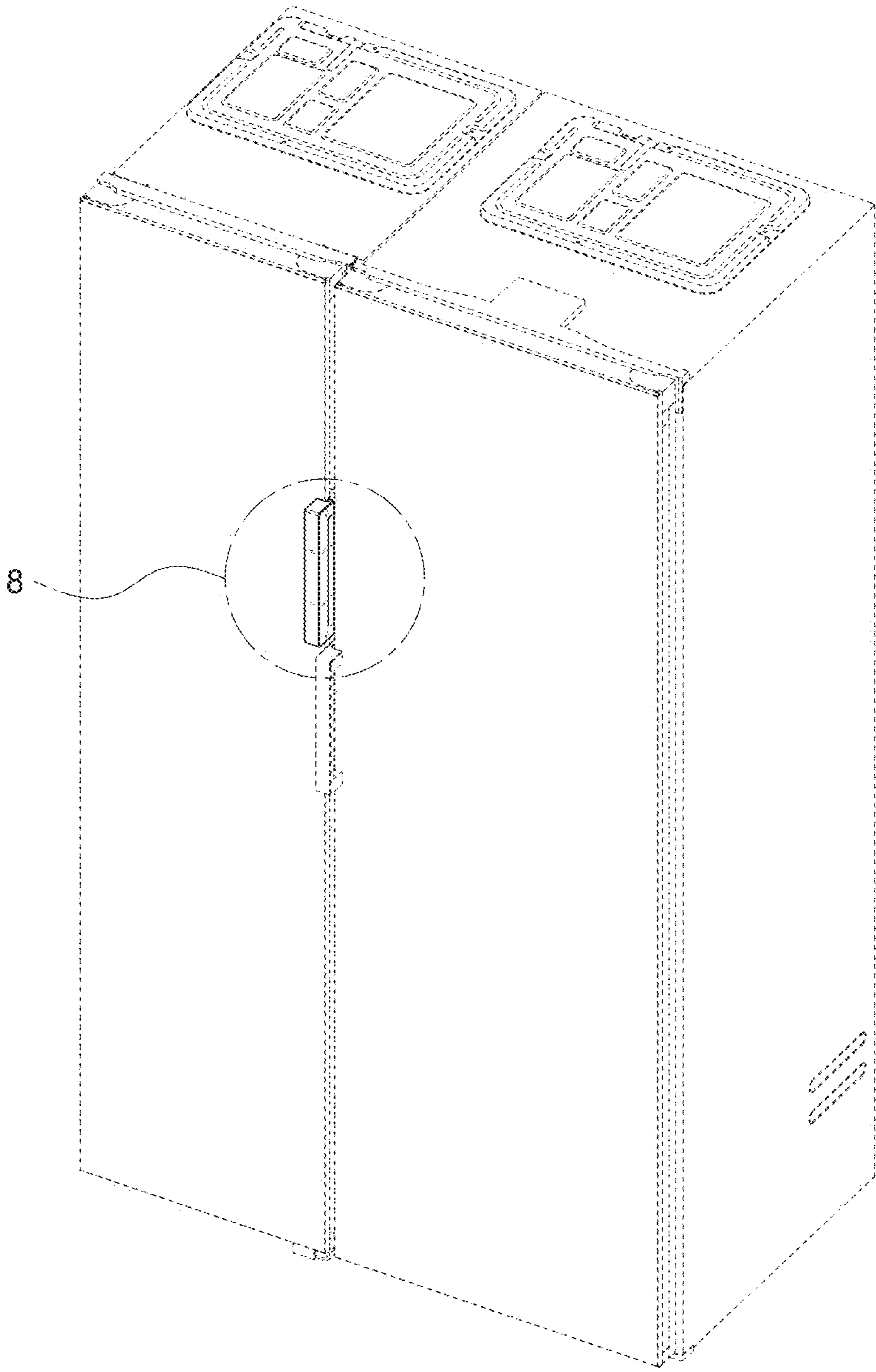

FIG. 2

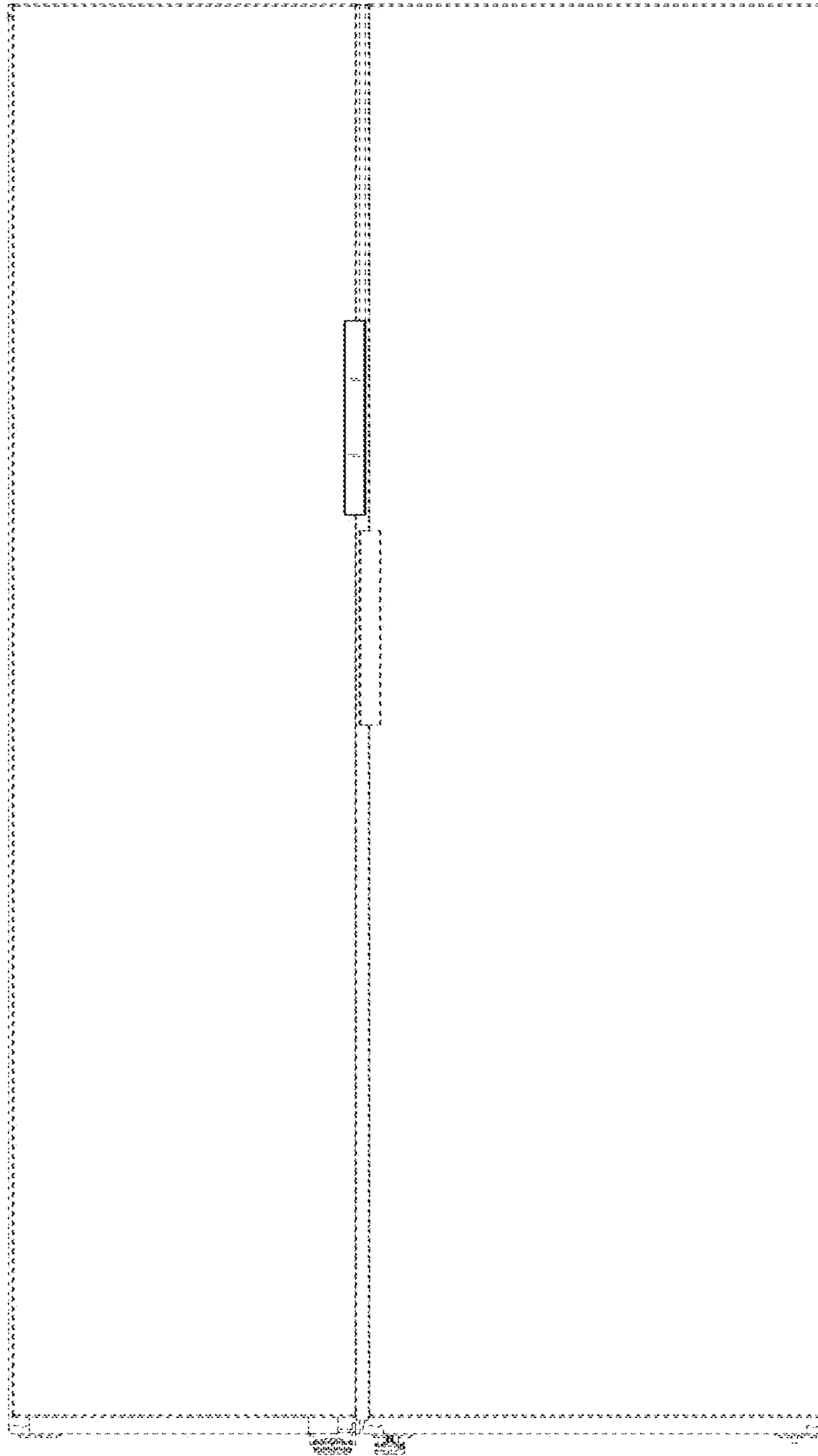

FIG. 3

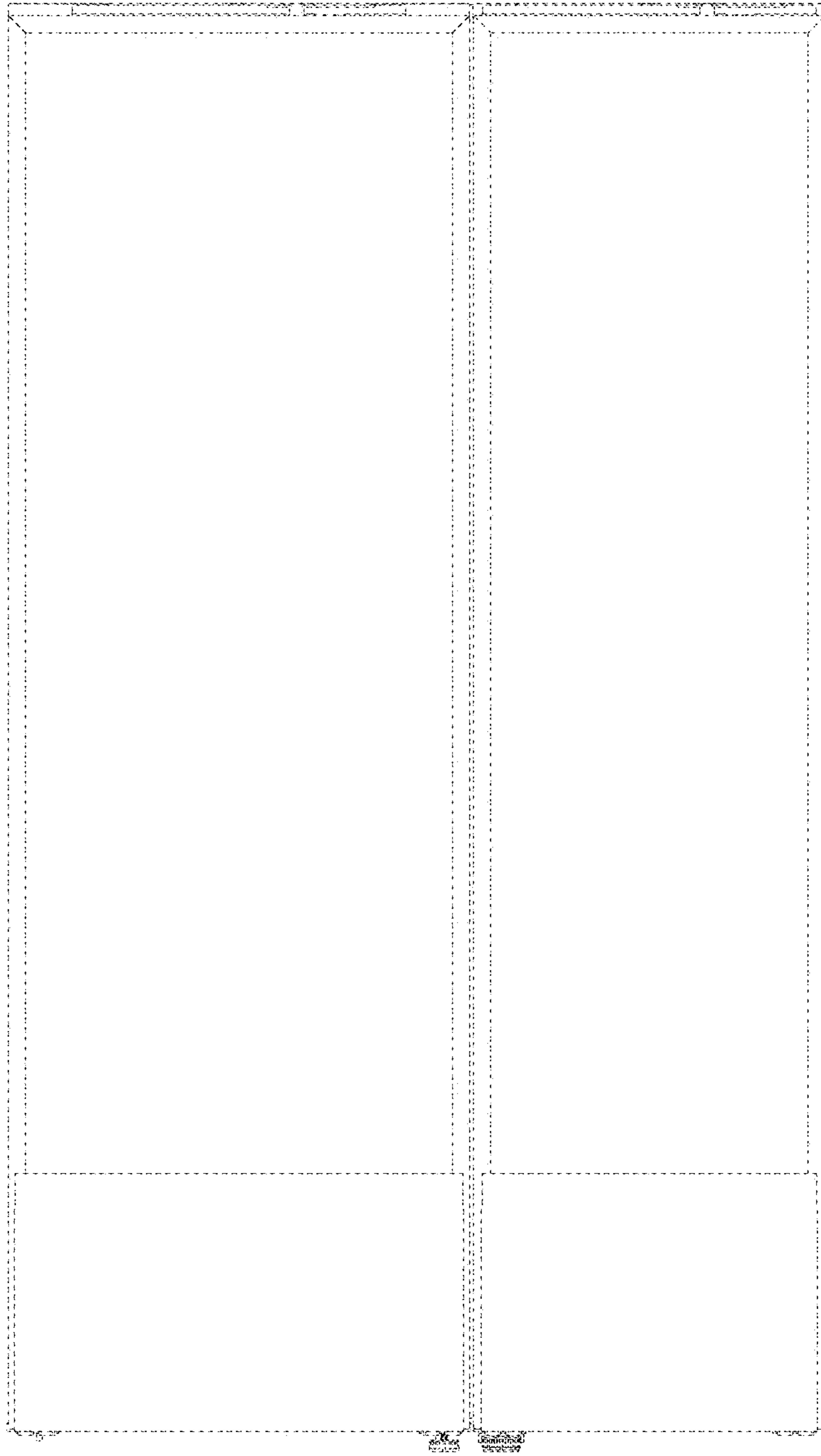

FIG. 4

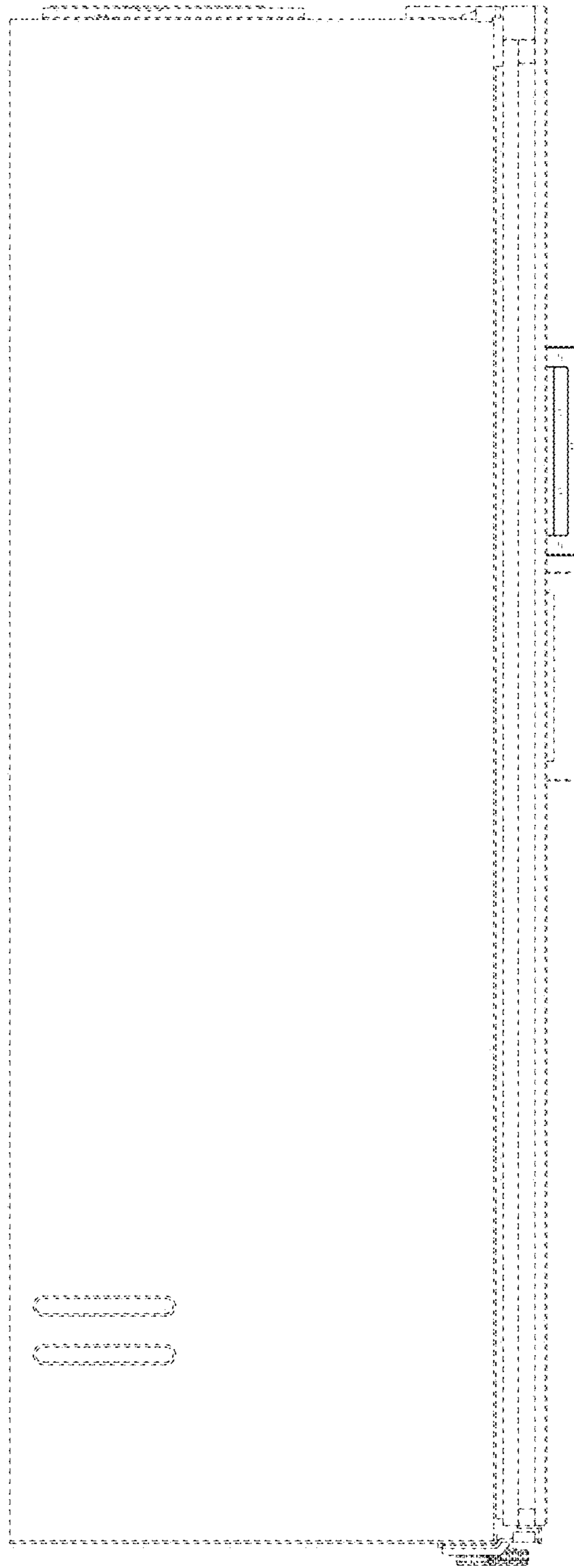

FIG. 5

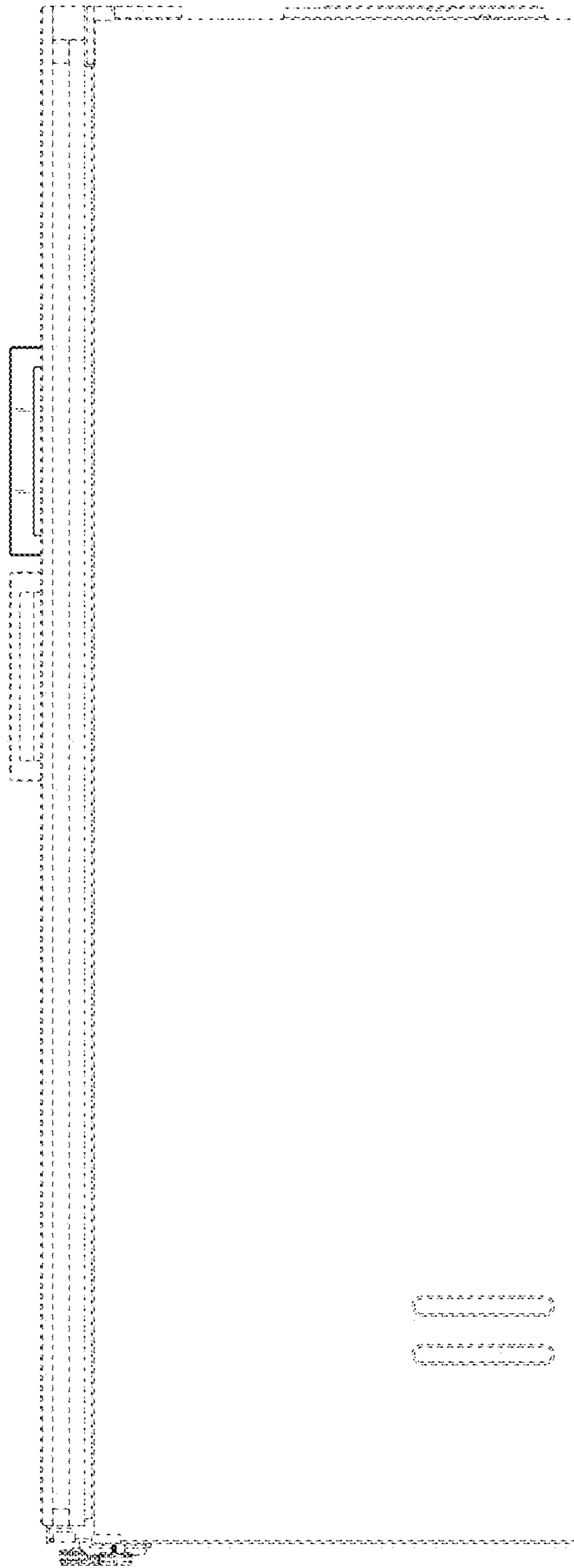

FIG. 6

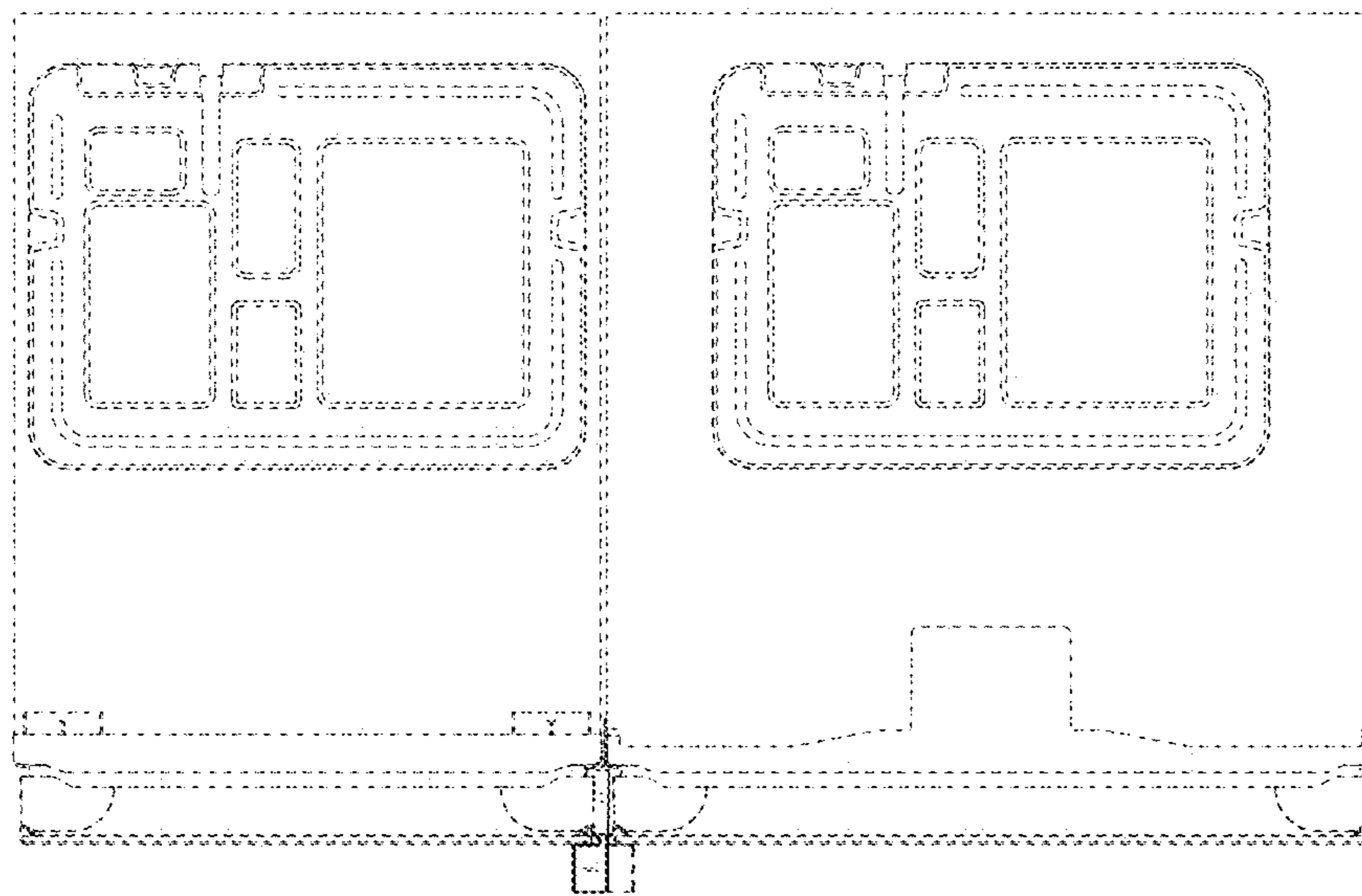

FIG. 7

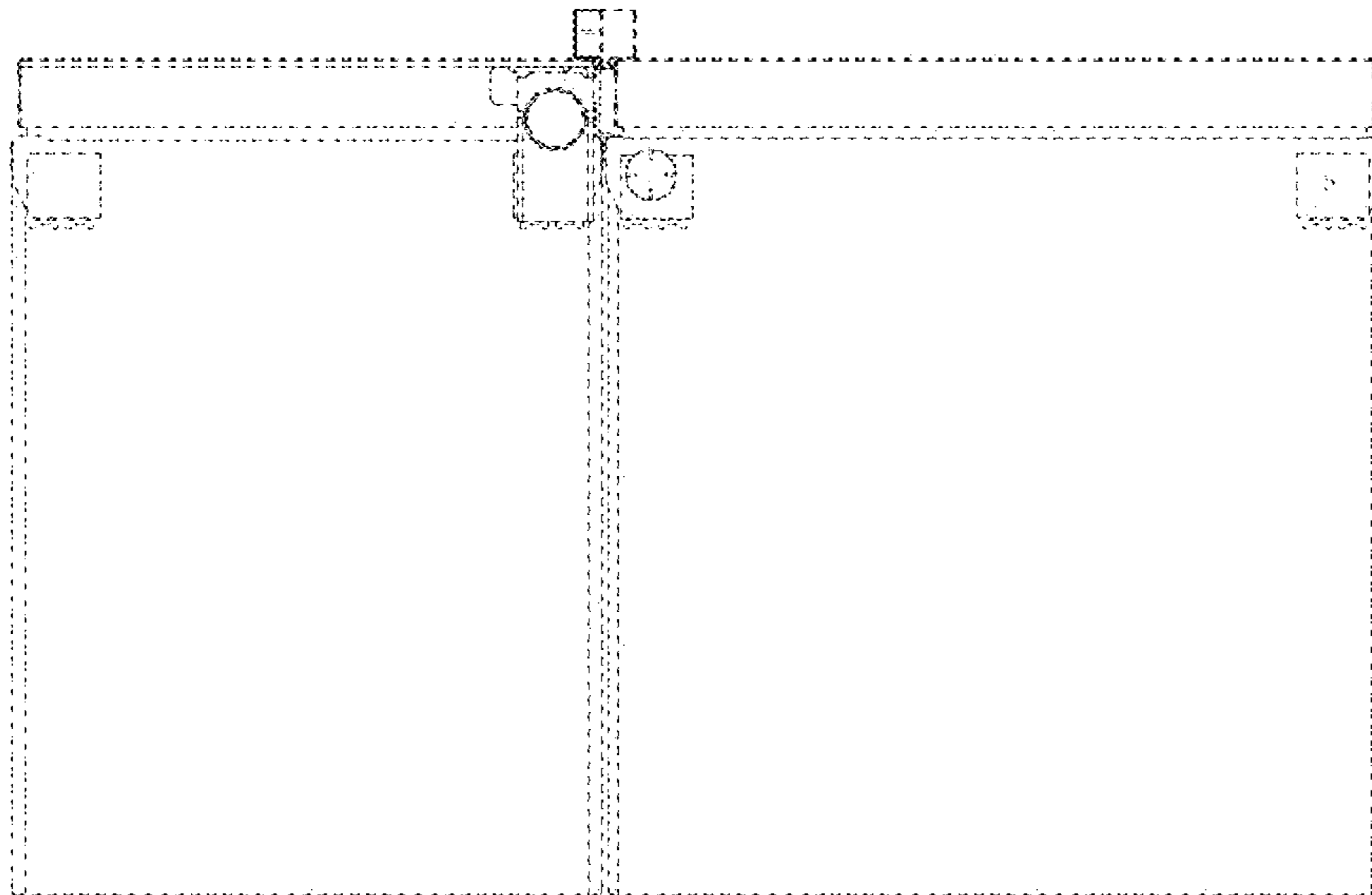

FIG. 8

