



US00D921541S

(12) **United States Design Patent**
Chambers et al.

(10) **Patent No.:** **US D921,541 S**
(45) **Date of Patent:** **** Jun. 8, 2021**

- (54) **MOTORBIKE STEM HEADSET**
- (71) Applicant: **Super73, Inc.**, Irvine, CA (US)
- (72) Inventors: **Ian Chambers**, Irvine, CA (US);
Legrand Crewse, Irvine, CA (US)
- (73) Assignee: **Super 73, Inc.**, Irvine, CA (US)
- (**) Term: **15 Years**
- (21) Appl. No.: **29/722,035**
- (22) Filed: **Jan. 24, 2020**
- (51) **LOC (13) Cl.** **12-11**
- (52) **U.S. Cl.**
USPC **D12/118**
- (58) **Field of Classification Search**
USPC D12/111, 114, 117, 118; 403/370, 373,
403/374; 280/280, 279, 289 R
CPC B62K 12/14; B62K 15/08; B62K 19/40;
B62K 21/12; B62K 21/16; B62K 21/18;
B62K 25/02; B62J 11/00
See application file for complete search history.

(56) **References Cited**

U.S. PATENT DOCUMENTS

- 4,435,983 A * 3/1984 Shimano B62K 21/12
73/493
- 4,489,307 A * 12/1984 Nagano B62K 21/12
340/432
- D341,801 S * 11/1993 McCormack D12/118
- D354,259 S * 1/1995 Kurke D12/118
- D362,650 S * 9/1995 Burns D12/118
- D410,869 S * 6/1999 Singer D12/114

(Continued)

OTHER PUBLICATIONS

“Race Face Cockpit” VitalMTB., posted date Jul. 31, 2019 [online],
[retrieved on Jan. 22, 2021], Retrieved from the Internet <URL:

[https://www.vitalmtb.com/photos/features/Pro-Bike-Check-George-Brannigans-GT-Fury, 12519/Race-Face-Cockpit, 131336/sspomer,2](https://www.vitalmtb.com/photos/features/Pro-Bike-Check-George-Brannigans-GT-Fury,12519/Race-Face-Cockpit,131336/sspomer,2) (Year: 2019).*

(Continued)

Primary Examiner — Darlington Ly

Assistant Examiner — Nasim Abdulaziz Ali

(74) *Attorney, Agent, or Firm* — Stradling Yocca Carlson & Rauth

(57) **CLAIM**

The ornamental design for a motorbike stem headset, as shown and described.

DESCRIPTION

FIG. 1 is a top perspective view showing environmental structure of the top, rear, and right sides of a motorbike stem headset;

FIG. 2 is a top perspective view showing environmental structure of the top, front, and left sides of the motorbike stem headset;

FIG. 3 is a top perspective view showing the top, front, and left sides of the motorbike stem headset;

FIG. 4 is a top perspective view showing the top, rear, and right sides of the motorbike stem headset;

FIG. 5 is a right side elevation view of the motorbike stem headset;

FIG. 6 is a left side elevation view of the motorbike stem headset;

FIG. 7 is a front elevation view of the motorbike stem headset;

FIG. 8 is a rear elevation view of the motorbike stem headset;

FIG. 9 is a top plan view of the motorbike stem headset; and,

FIG. 10 is a bottom plan view of the motorbike stem headset. The broken line showing of portions of the motorbike are provided for the purpose of illustrating environmental structure and form no part of the claimed design.

1 Claim, 6 Drawing Sheets

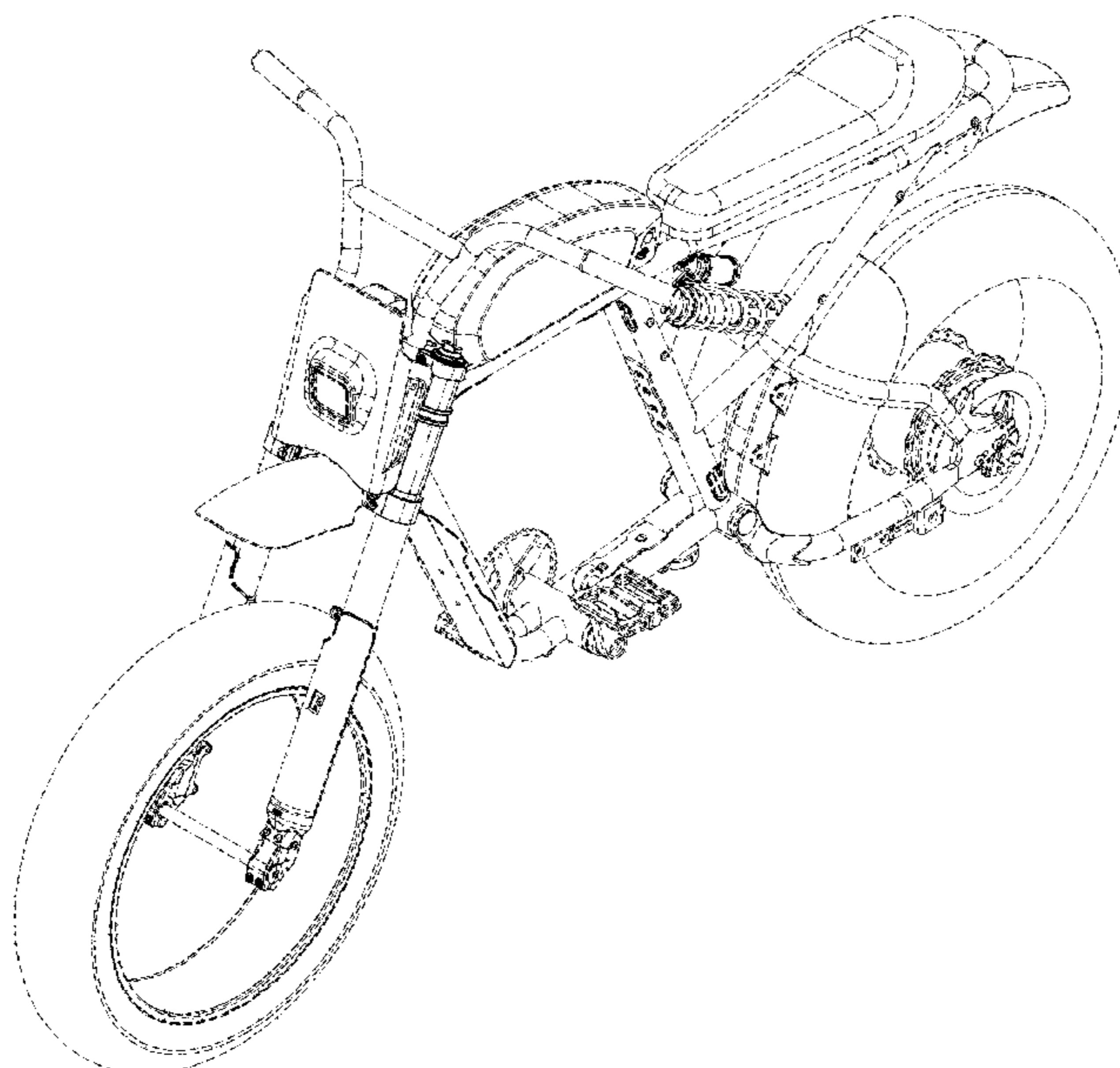

(56)

References Cited

U.S. PATENT DOCUMENTS

6,305,241 B1 * 10/2001 Masui B62J 11/00
74/551.8
6,588,297 B1 * 7/2003 Day B62K 11/14
340/432
6,609,437 B2 * 8/2003 Jiang B62K 21/12
280/279
6,716,140 B2 * 4/2004 Cheng B62J 99/00
482/8
D548,143 S * 8/2007 Chen D12/118
D580,262 S * 11/2008 Eason F16B 7/0493
D8/396
8,651,350 B2 * 2/2014 Onogi B62J 11/00
224/421
D753,025 S * 4/2016 Chen B62K 21/16
D12/118
10,046,825 B1 * 8/2018 Chen B62K 21/22
D845,838 S * 4/2019 Heideveld D12/118
D903,536 S * 12/2020 Haag D12/114

OTHER PUBLICATIONS

“New integrated aero cockpits” Bike Radar., posted date Jun. 14, 2018 [online], [retrieved on Jan. 22, 2021], Retrieved from the Internet <URL: <https://www.bikeradar.com/features/new-integrated-aero-cockpits-from-deda-specialized-trek-and-ridley/>> (Year: 2018).*

“Mountain Bike Cockpit” World Wide Cyclery., posted date May 26, 2019 [online], [retrieved on Jan. 22, 2021], Retrieved from the Internet <URL: <https://www.worldwidecyclery.com/blogs/worldwide-cyclery-blog/how-to-set-up-your-mountain-bike-cockpit/>> (Year: 2019).*

* cited by examiner

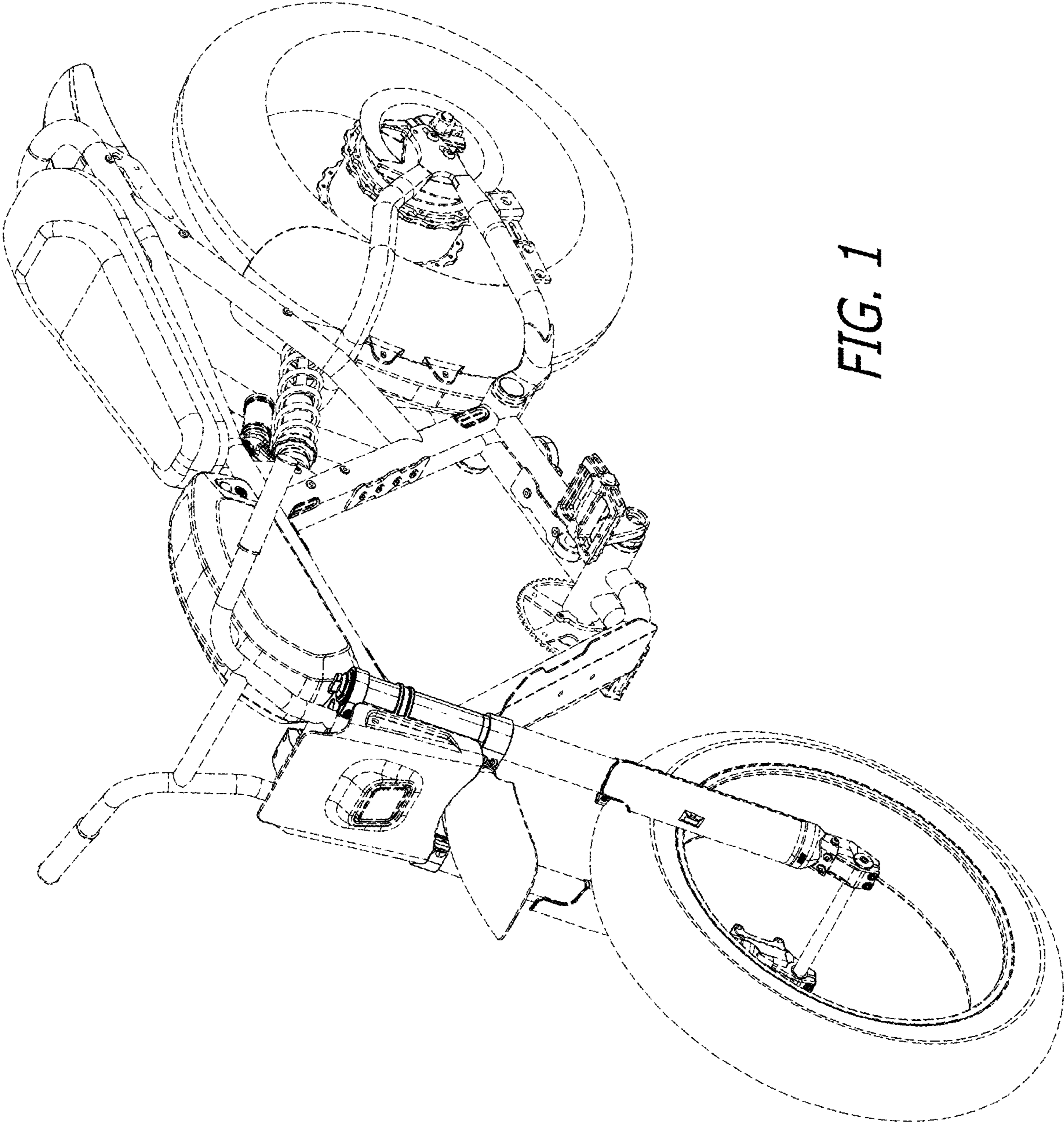

FIG. 1

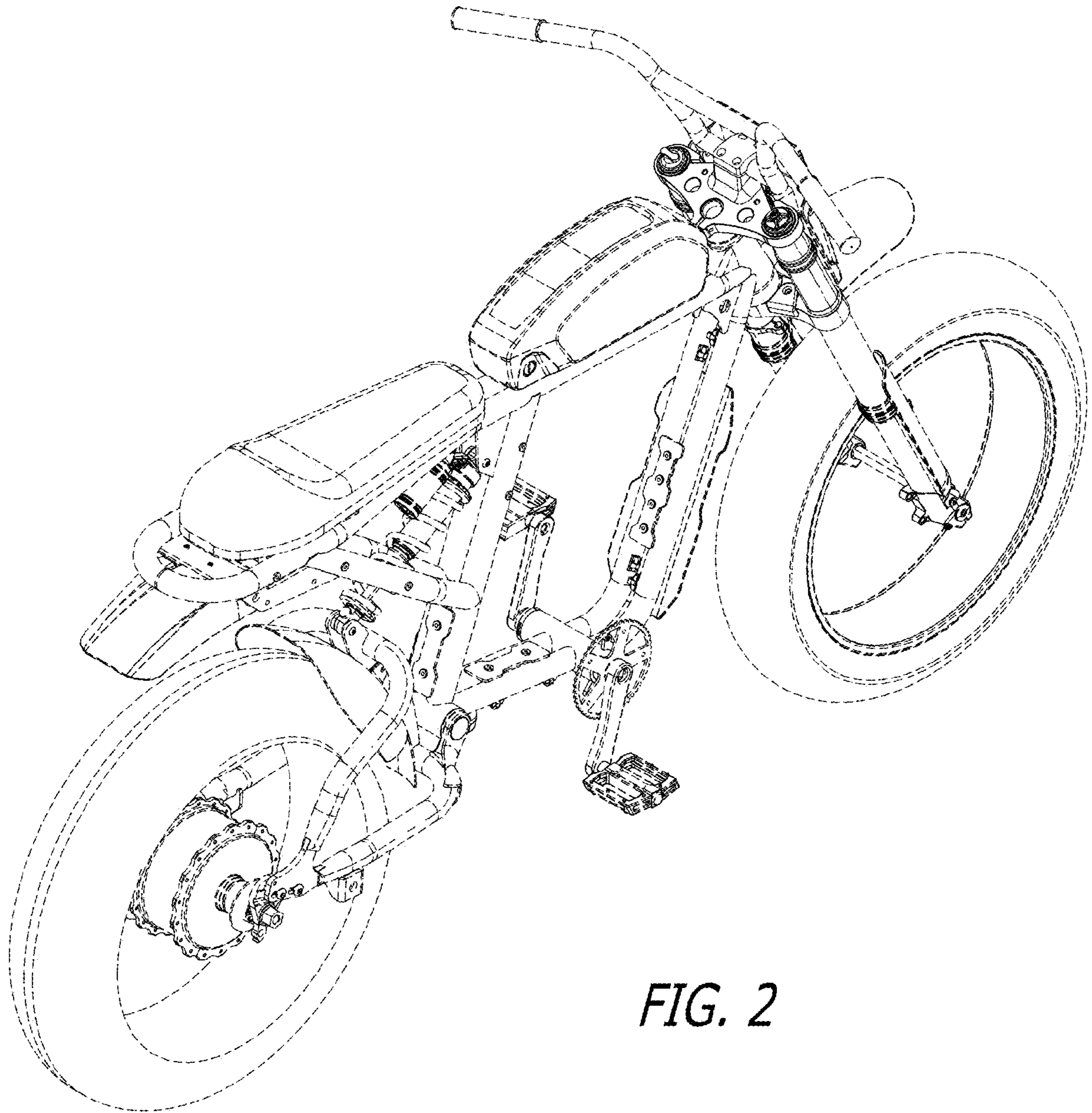

FIG. 2

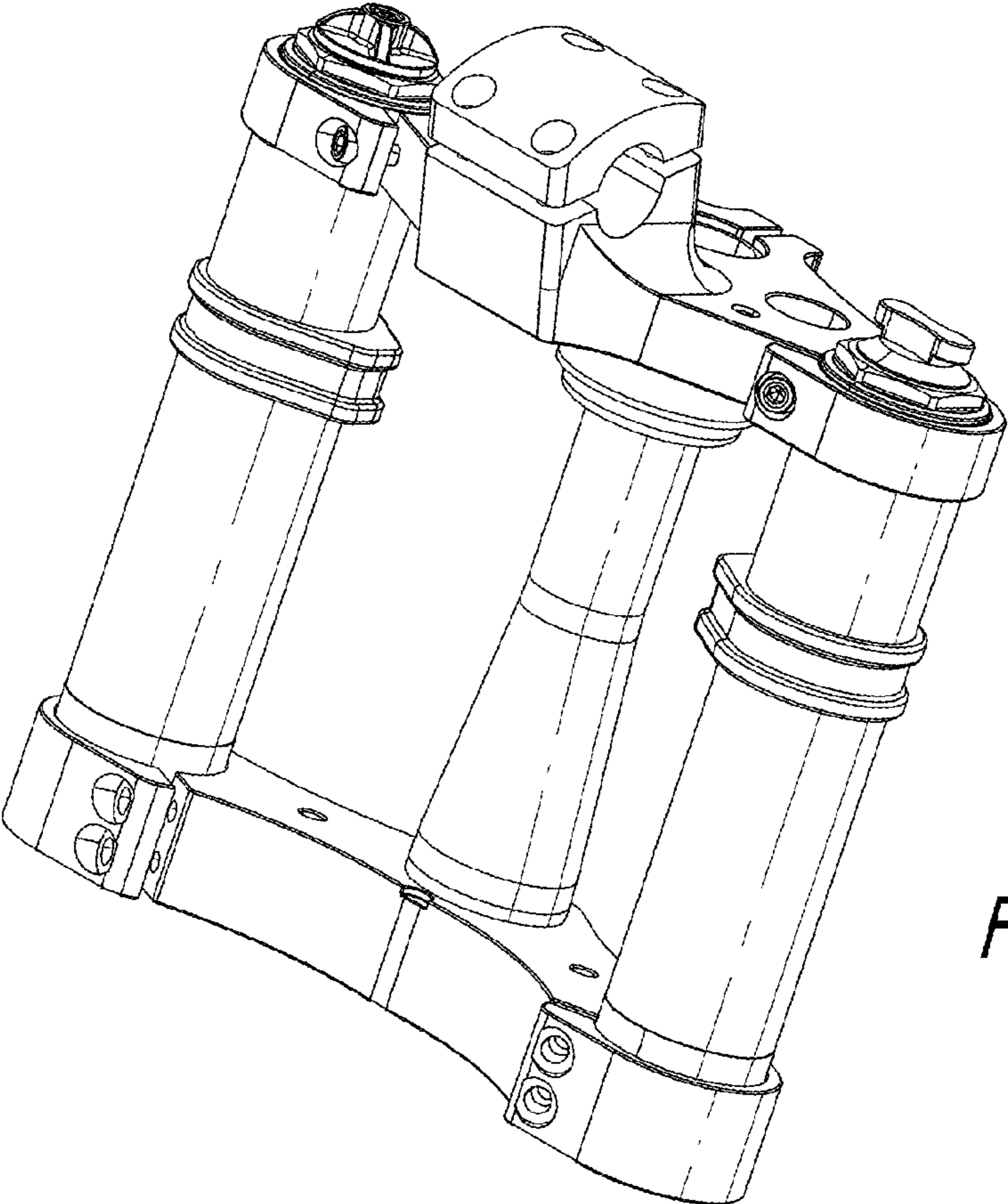

FIG. 3

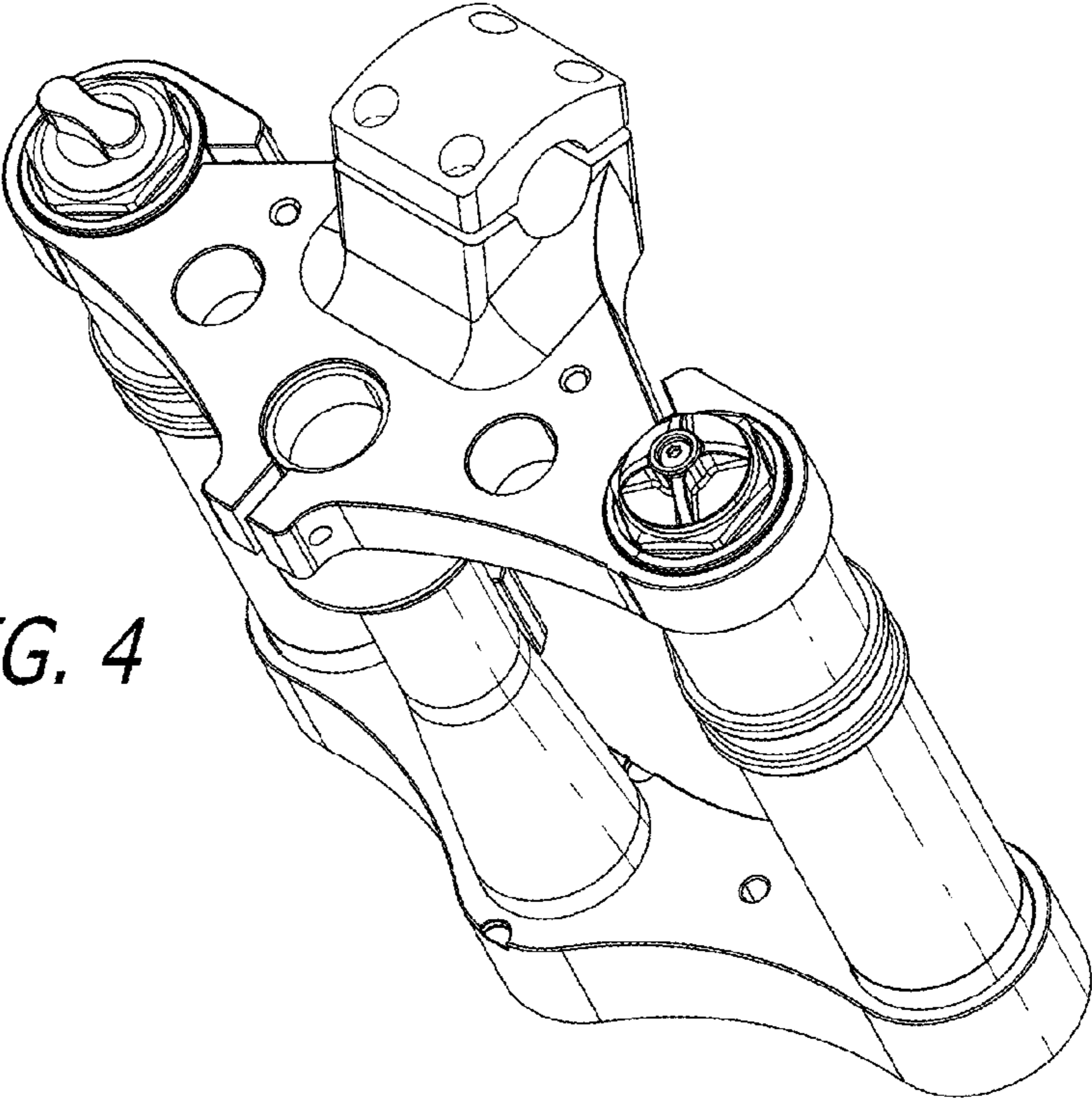

FIG. 4

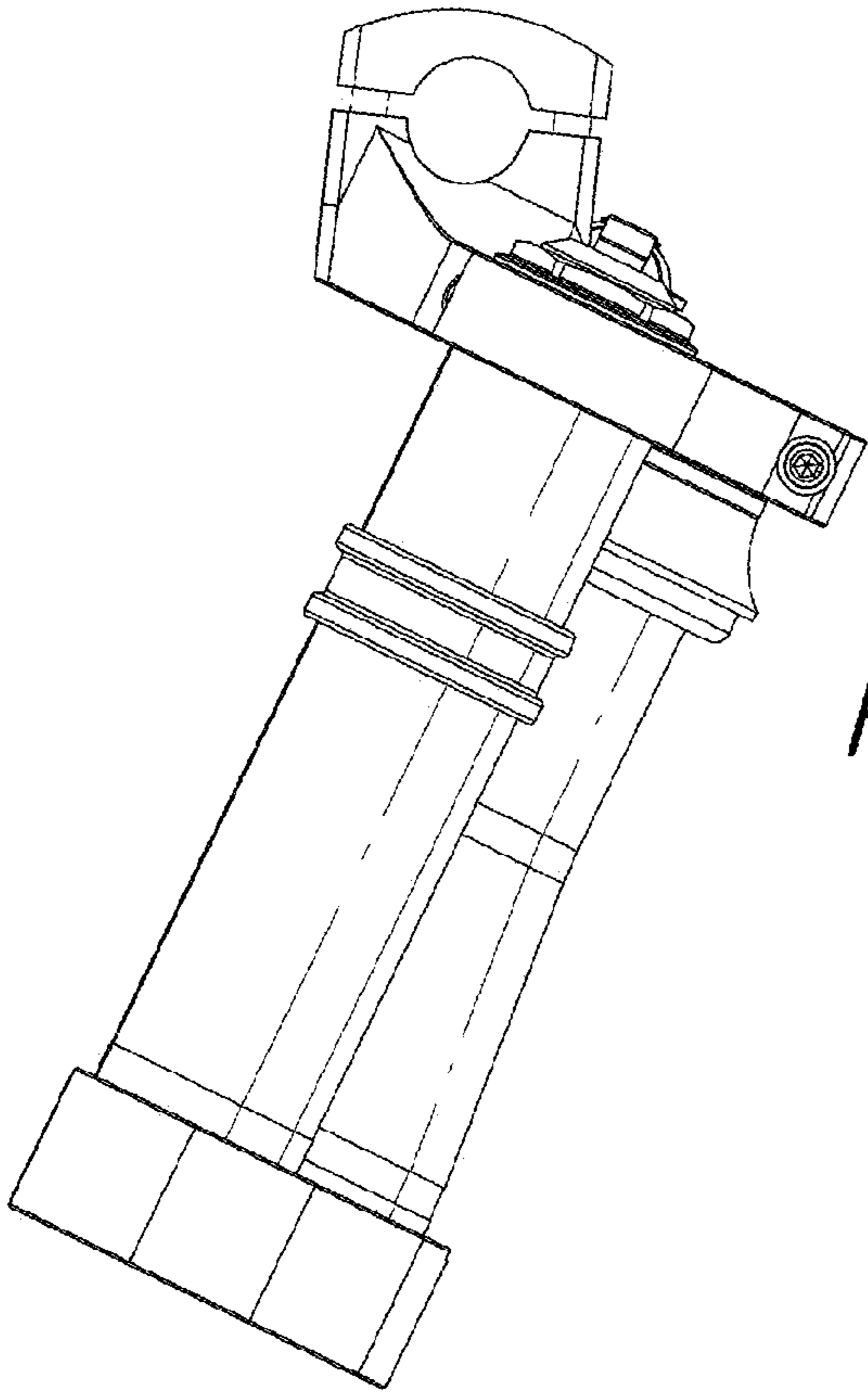

FIG. 5

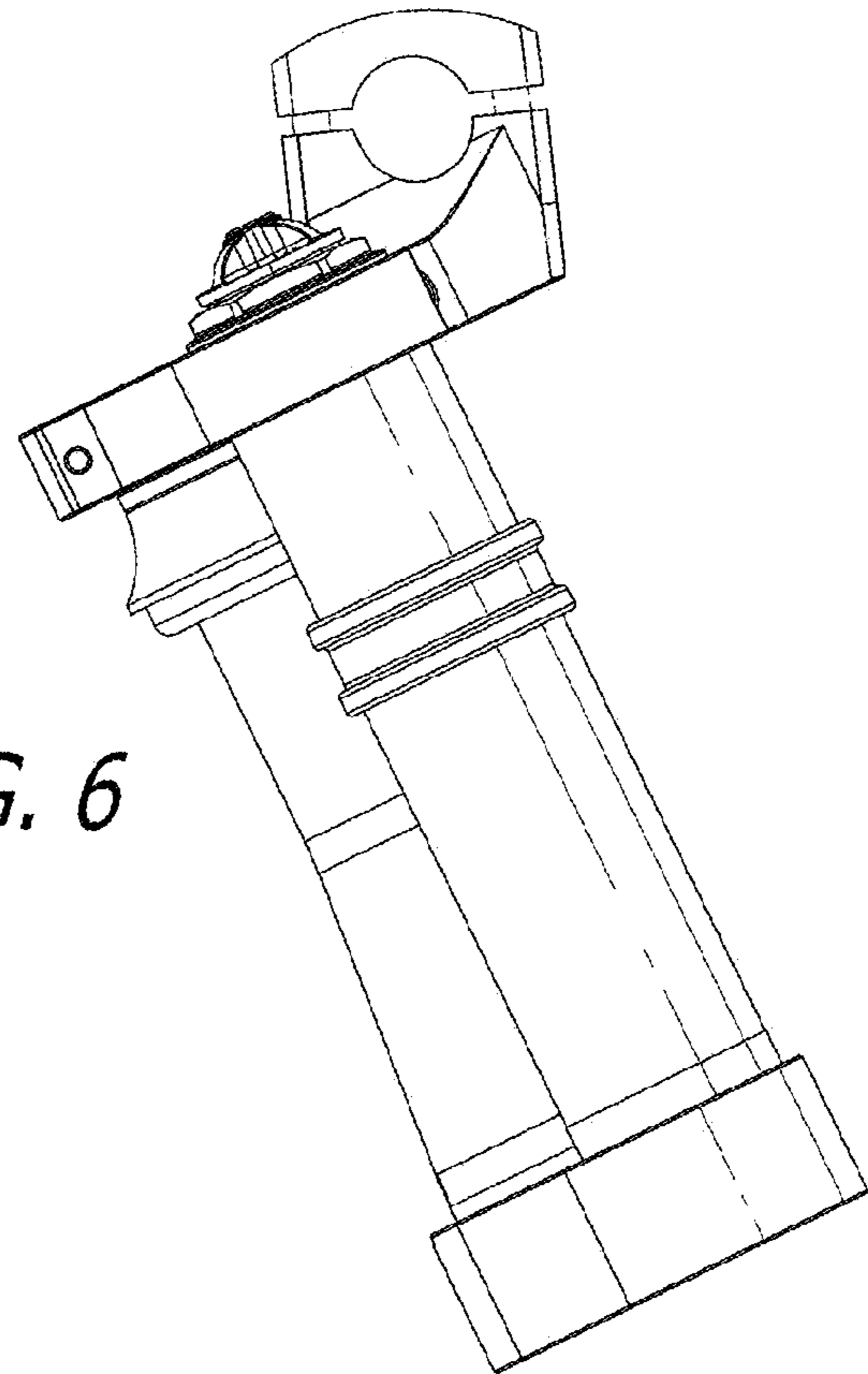

FIG. 6

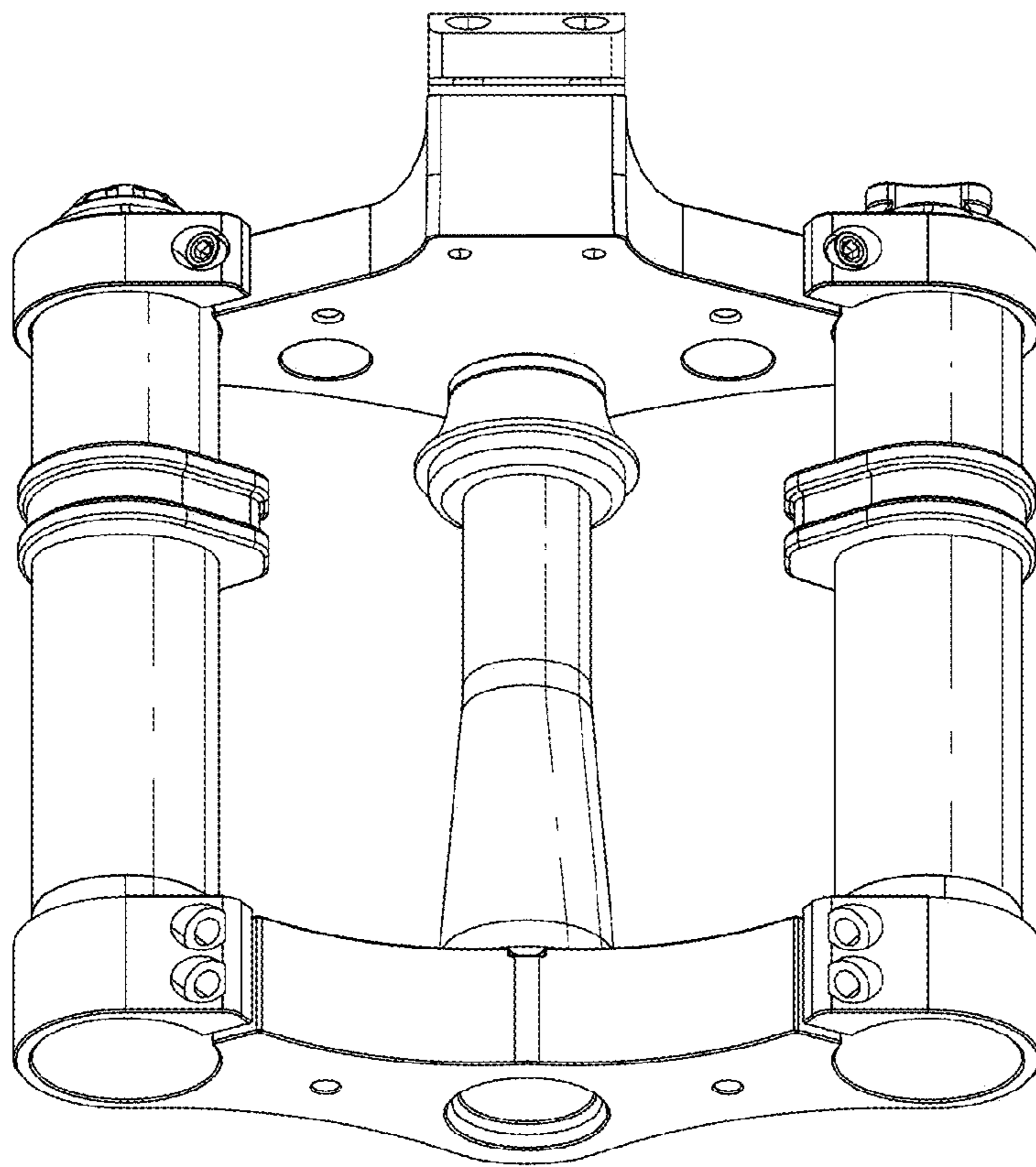

FIG. 7

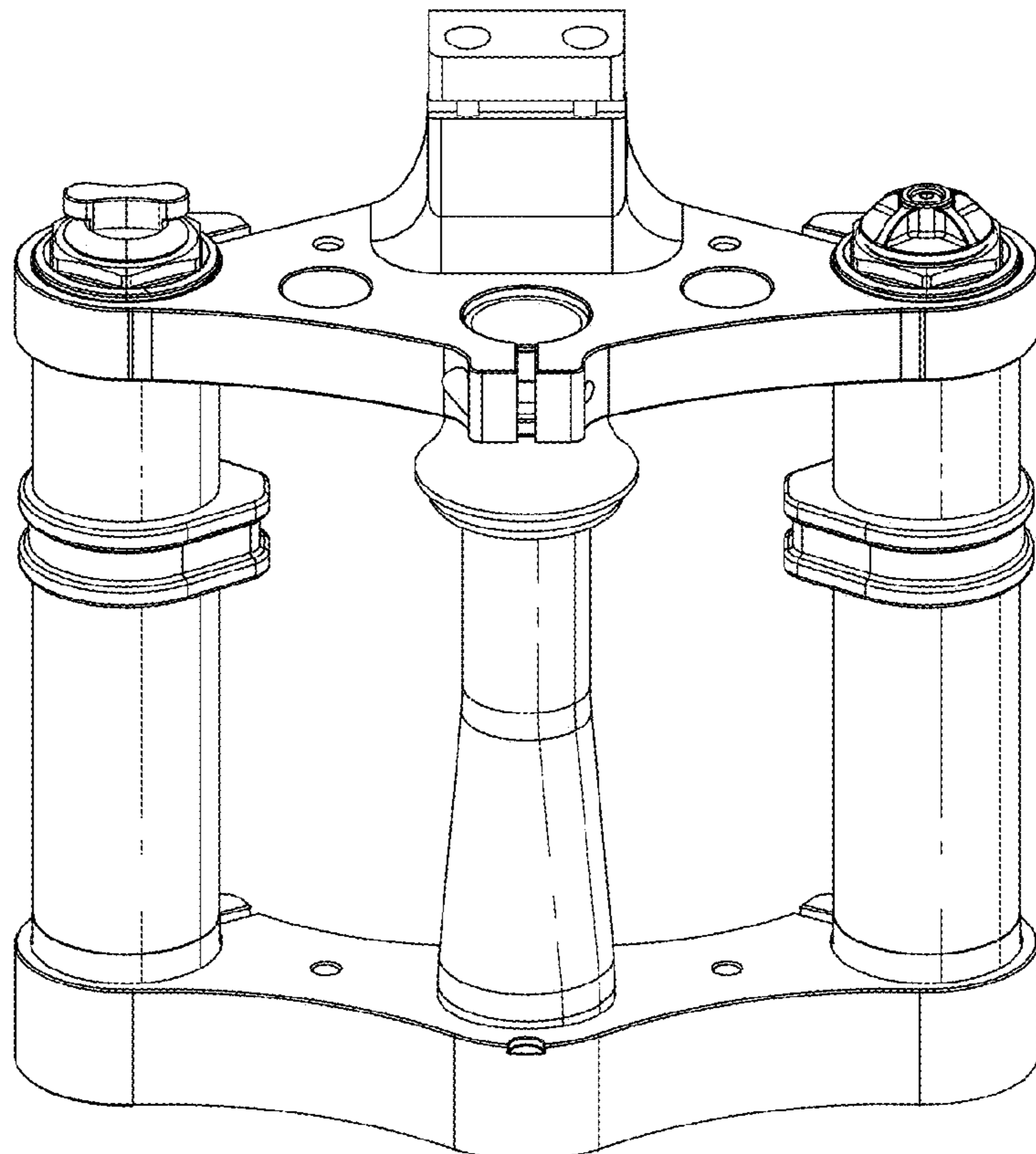

FIG. 8

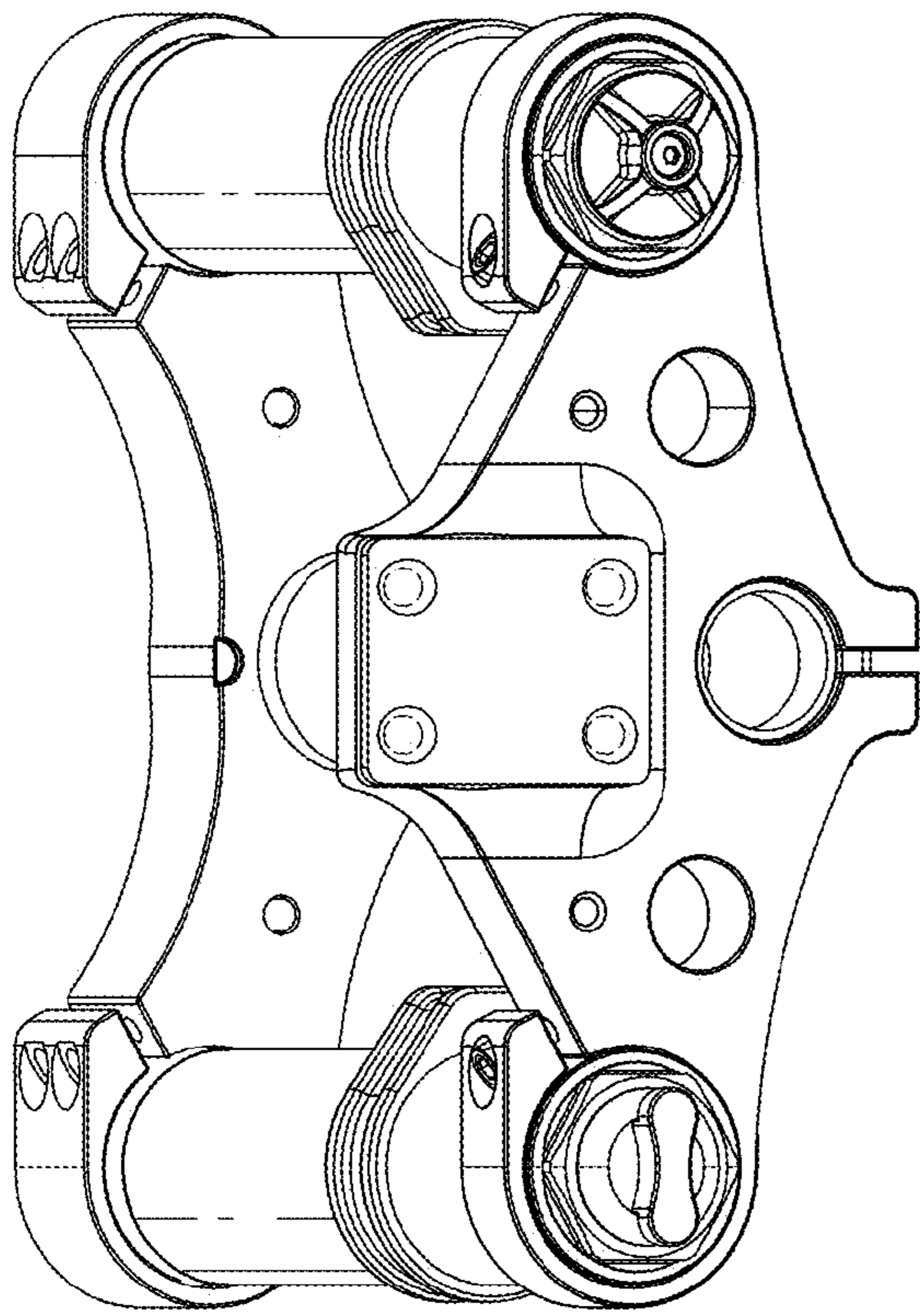

FIG. 9

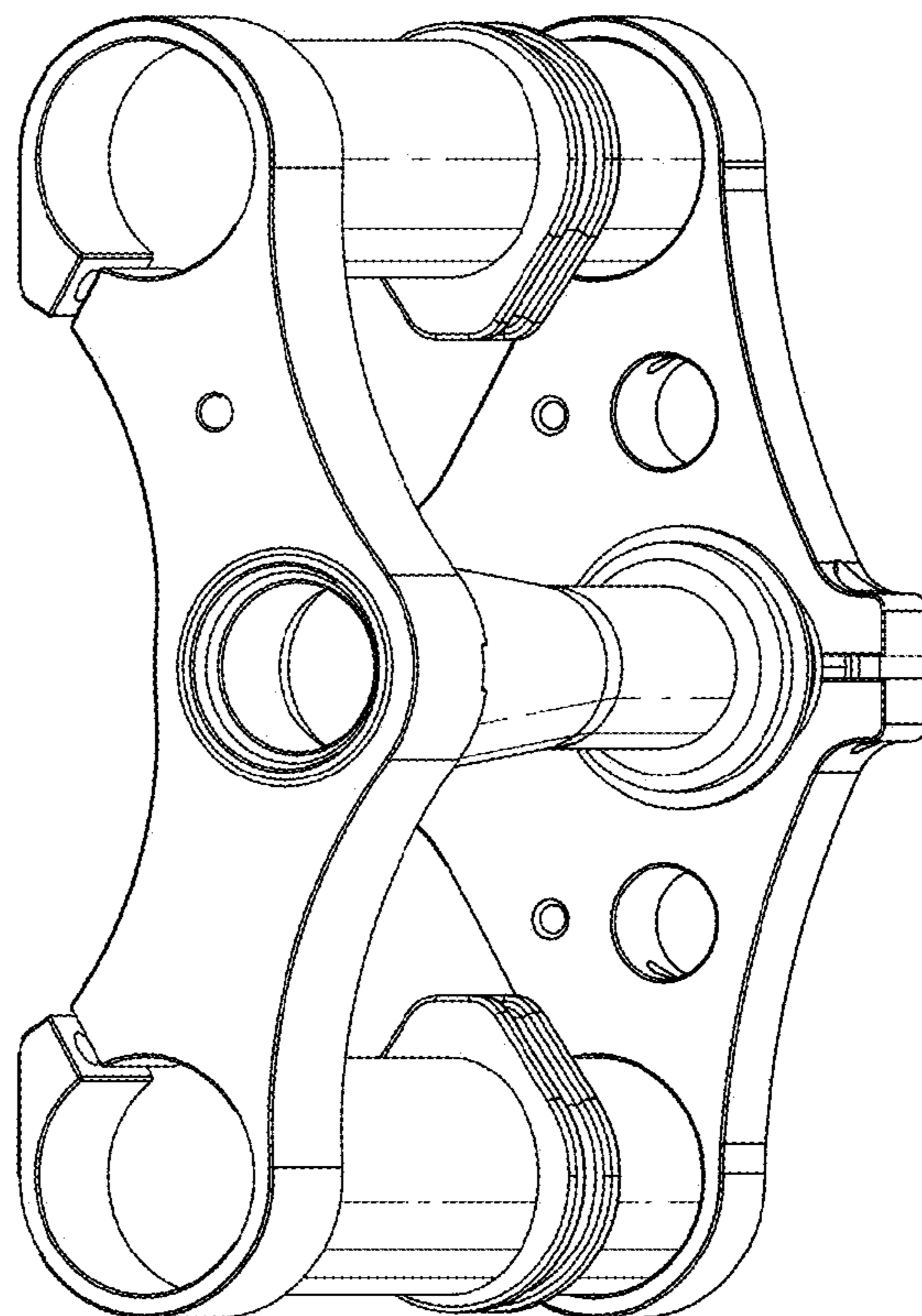

FIG. 10