



US00D921476S

(12) **United States Design Patent** (10) **Patent No.:** **US D921,476 S**
Berglund et al. (45) **Date of Patent:** **** Jun. 8, 2021**

- (54) **MERCHANDISE DISPLAY HOOK**
- (71) Applicant: **InVue Security Products Inc.**,
Charlotte, NC (US)
- (72) Inventors: **David N. Berglund**, Indian Trail, NC
(US); **Kirk Burmeister, II**, Charlotte,
NC (US); **Christopher Richard
Helman**, Charlotte, NC (US)
- (73) Assignee: **InVue Security Products Inc.**,
Charlotte, NC (US)
- (**) Term: **15 Years**
- (21) Appl. No.: **29/594,563**
- (22) Filed: **Feb. 21, 2017**
- (51) **LOC (13) Cl.** **08-05**
- (52) **U.S. Cl.**
USPC **D8/363**
- (58) **Field of Classification Search**
USPC D8/367, 354, 349, 389, 363, 373, 376;
D3/320, 323, 324, 327
CPC A47F 7/00; A47F 1/12
See application file for complete search history.

(56) **References Cited**

U.S. PATENT DOCUMENTS

D300,003 S *	2/1989	Hutchison	248/220.42
D300,301 S *	3/1989	Furst	D8/363
D411,097 S *	6/1999	Brousseau	D8/349
D411,436 S *	6/1999	Krehel	D6/327
D516,901 S *	3/2006	Murray	D8/376
D520,347 S *	5/2006	Silzer, Jr.	D8/363
D521,363 S *	5/2006	Copen	D8/363
D554,982 S *	11/2007	Wenck	D8/376
7,559,437 B2	7/2009	Colelli et al.	
D612,712 S *	3/2010	Rix	D16/242
D637,894 S *	5/2011	Maurer	D8/373
D661,572 S *	6/2012	Bowman	D8/363
D668,134 S *	10/2012	Barkdoll	D8/370

8,523,012 B2 9/2013 Richardson et al.
8,684,227 B2 4/2014 Richardson et al.
D717,155 S * 11/2014 Sawada D8/349
(Continued)

Primary Examiner — Christy Nemeth
(74) *Attorney, Agent, or Firm* — InVue Security Products
Inc.

(57) **CLAIM**

We claim the ornamental design for a merchandise display
hook, as shown and described.

DESCRIPTION

FIG. 1 is a perspective view of a merchandise display hook
showing our new design, according to a first embodiment;
FIG. 2 is a front view thereof;
FIG. 3 is a rear view thereof;
FIG. 4 is left side view thereof;
FIG. 5 is right side view thereof;
FIG. 6 is a top view thereof;
FIG. 7 is a bottom view thereof;
FIG. 8 is a perspective view of a merchandise display hook
showing our new design, according to a second embodi-
ment;
FIG. 9 is a front view thereof;
FIG. 10 is a rear view thereof;
FIG. 11 is left side view thereof;
FIG. 12 is right side view thereof;
FIG. 13 is a top view thereof; and,
FIG. 14 is a bottom view thereof.

The broken lines in the drawings are for the purpose of
illustrating environmental subject matter and portions of the
merchandise display hook that form no part of the claimed
design.

The second embodiment of the merchandise display hook is
shown with a symbolic break in its length. The appearance
of any portion of the article between the break lines forms
no part of the claimed design.

1 Claim, 12 Drawing Sheets

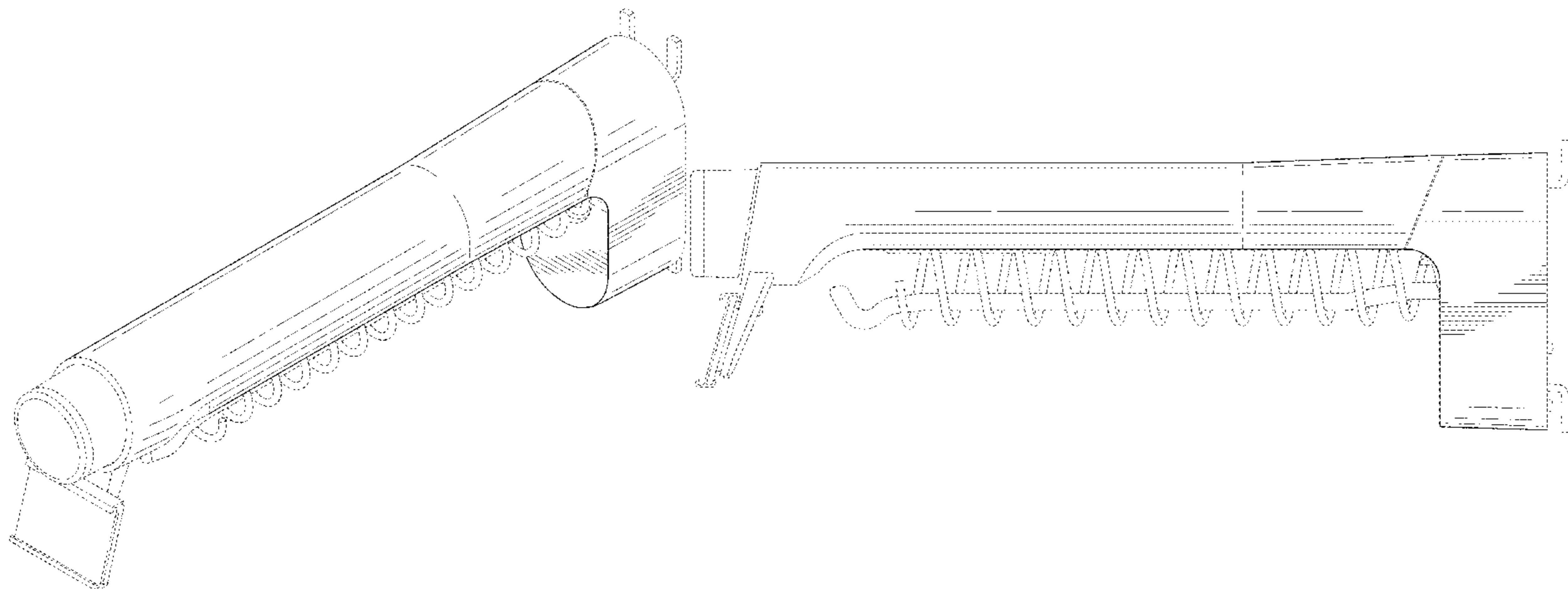

(56)

References Cited

U.S. PATENT DOCUMENTS

D727,715 S * 4/2015 Munson D8/354
D746,664 S * 1/2016 Najieb D23/411
D760,068 S * 6/2016 Sehl D8/367
9,675,184 B2 * 6/2017 Xin A47F 1/128
D825,318 S * 8/2018 Siegel D8/363
10,111,540 B2 * 10/2018 Brej A47F 1/128
D858,116 S * 9/2019 Wierbicki D6/323
2007/0241069 A1 * 10/2007 Nagelski A47F 5/0823
211/57.1
2011/0127225 A1 * 6/2011 Hooks, Jr. A47F 5/0861
211/1.57
2012/0253508 A1 10/2012 Holmes
2018/0296007 A1 * 10/2018 Berglund A47F 1/128

* cited by examiner

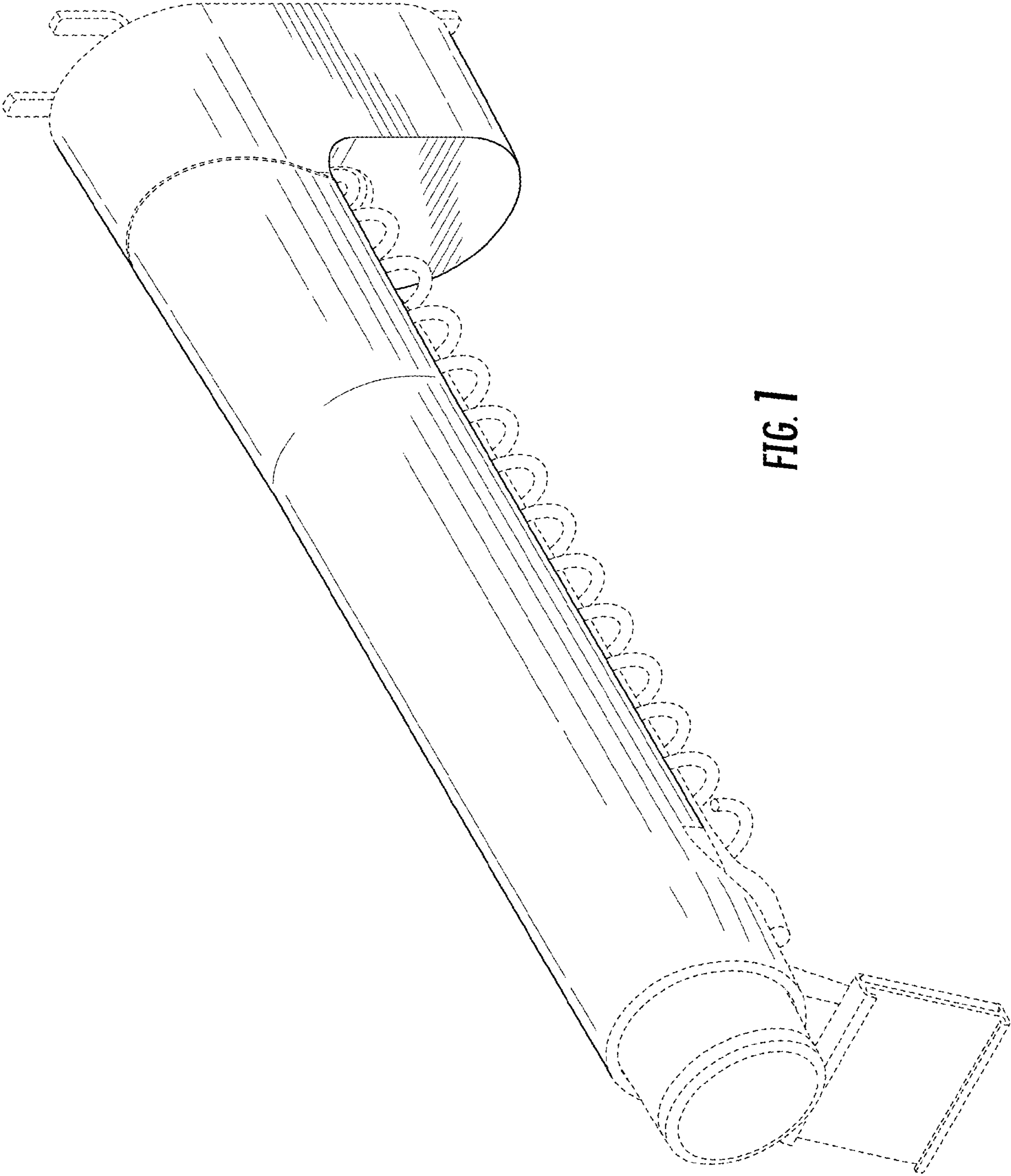

FIG. 1

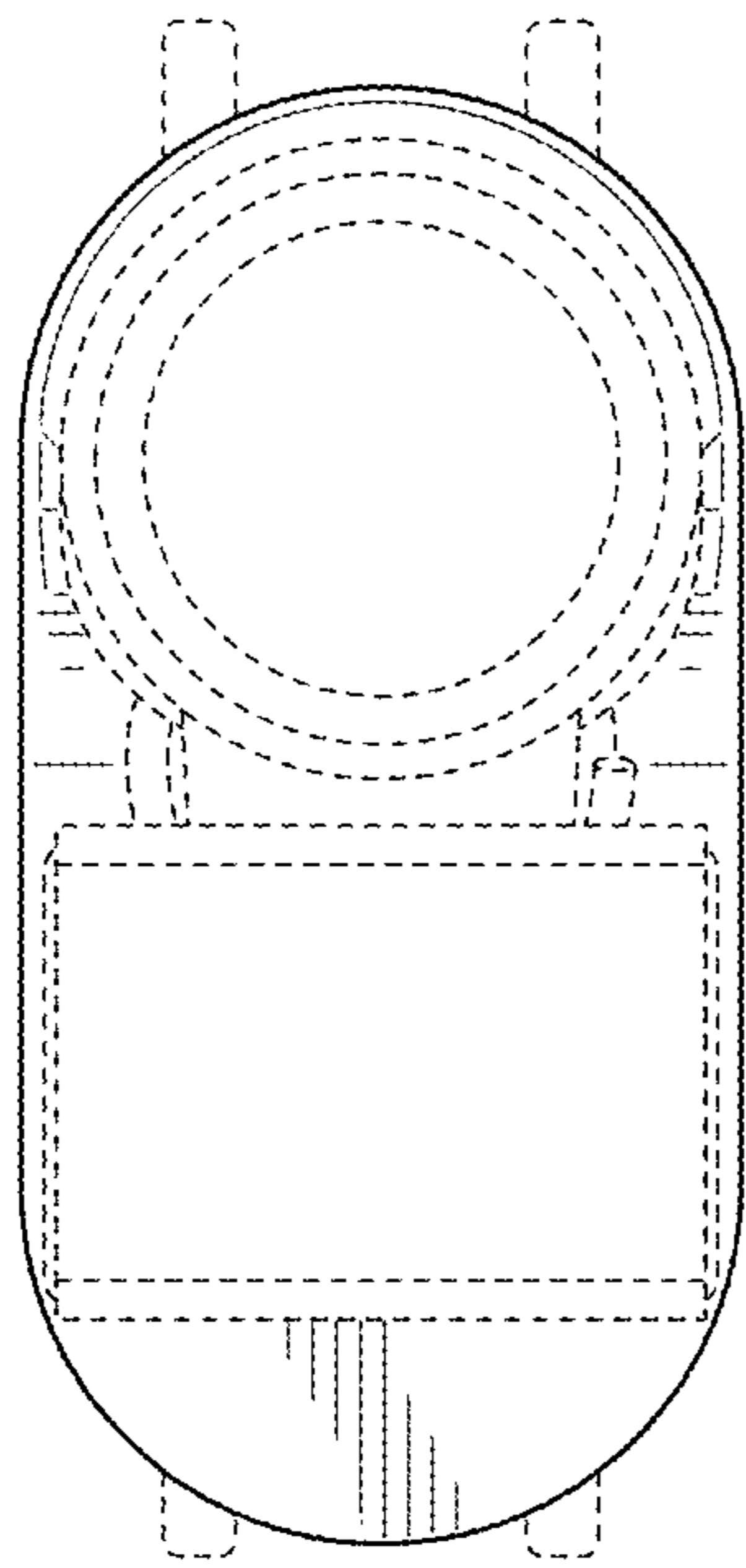

FIG. 2

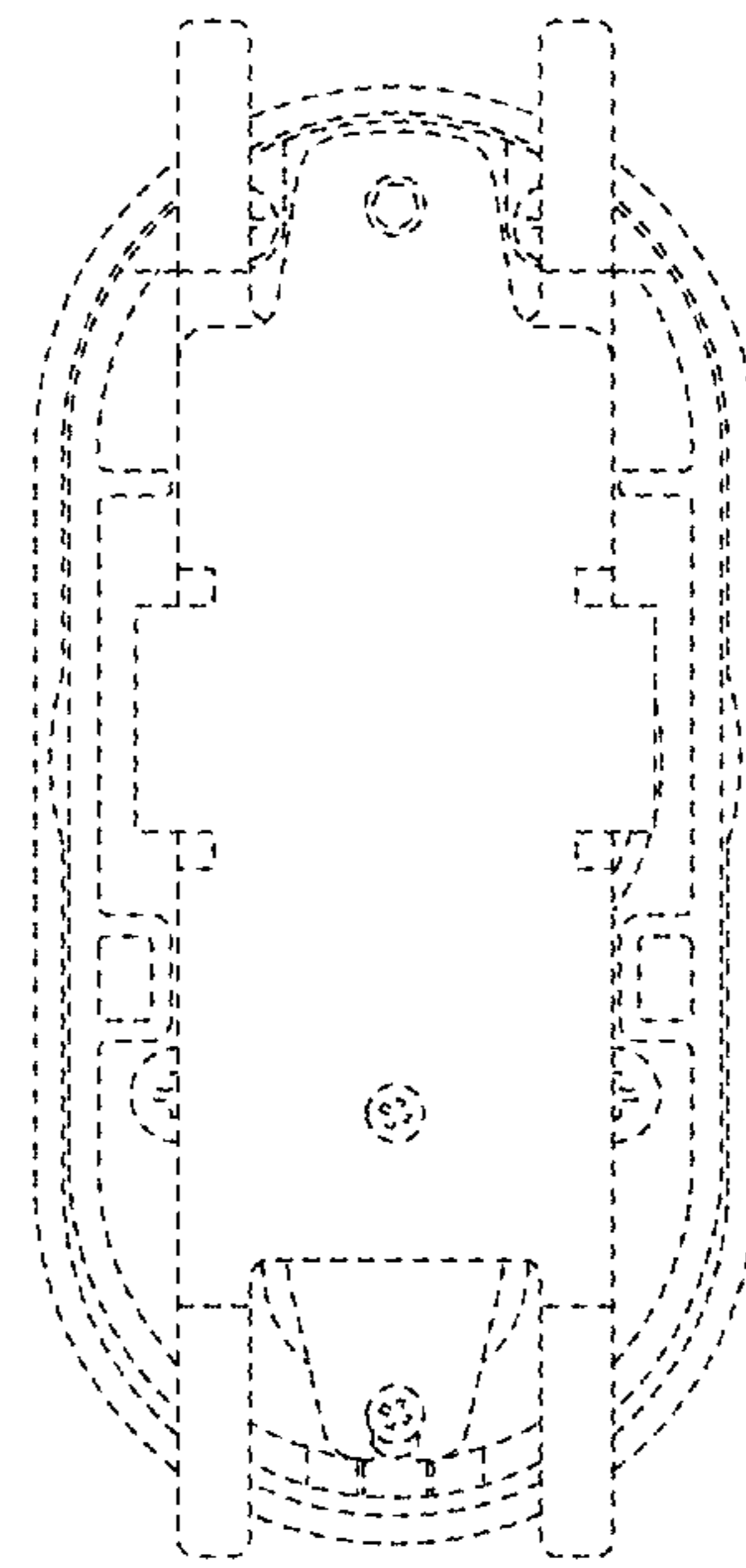

FIG. 3

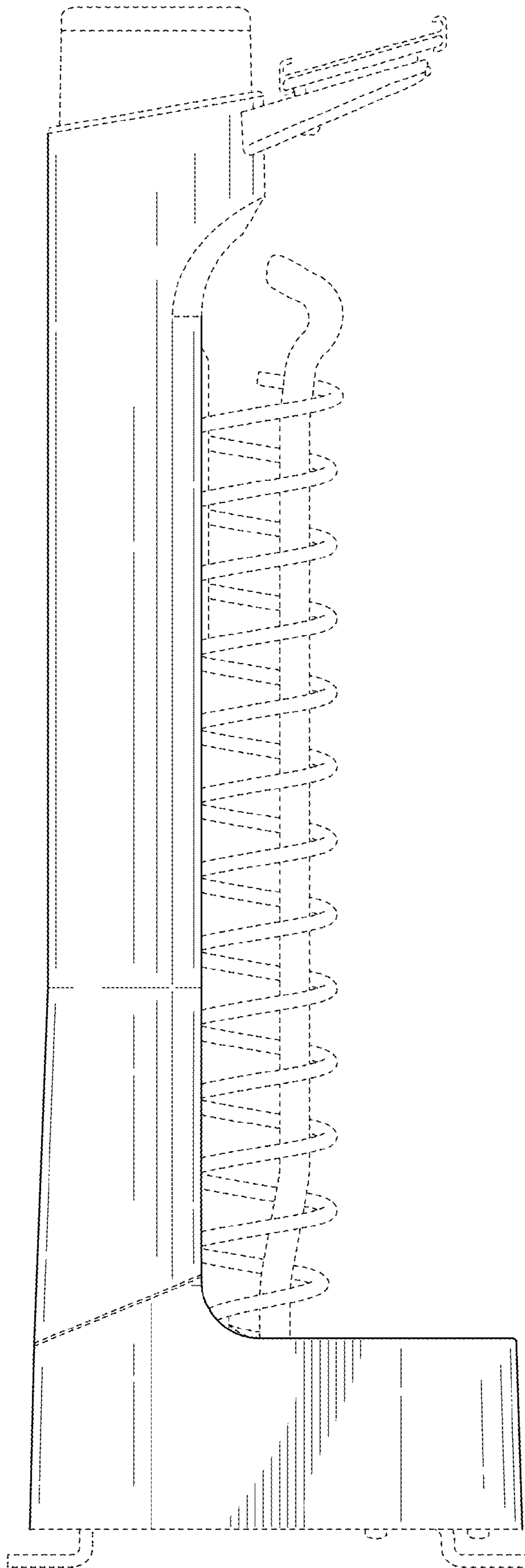

FIG. 4

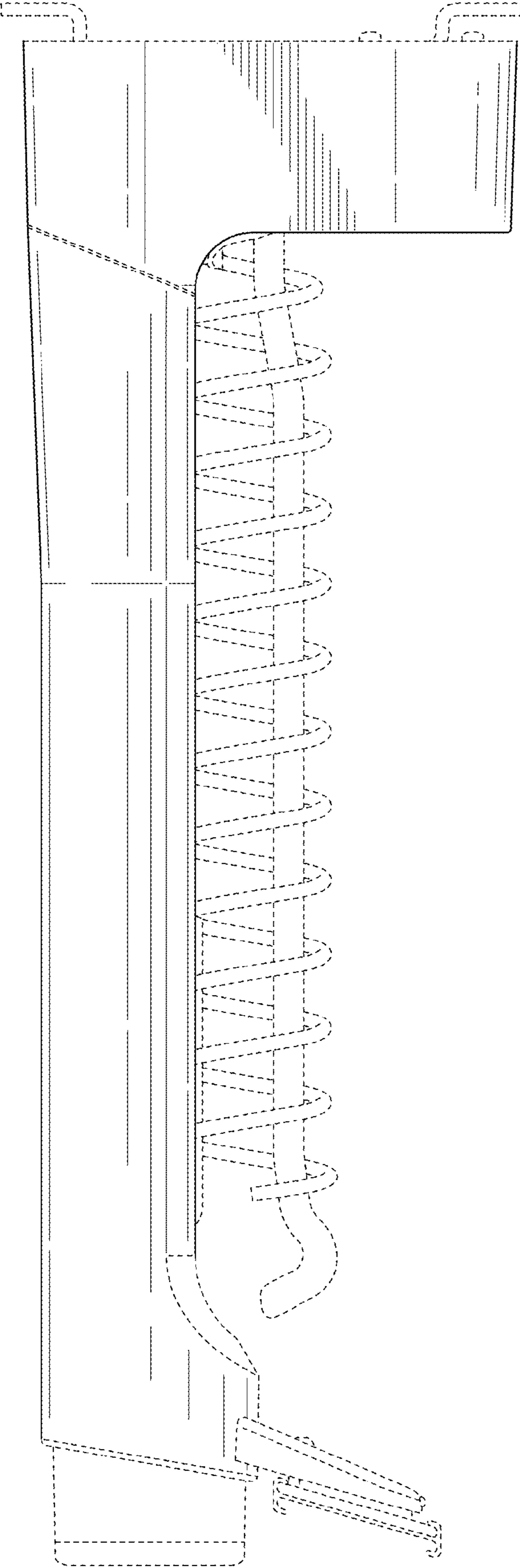

FIG. 5

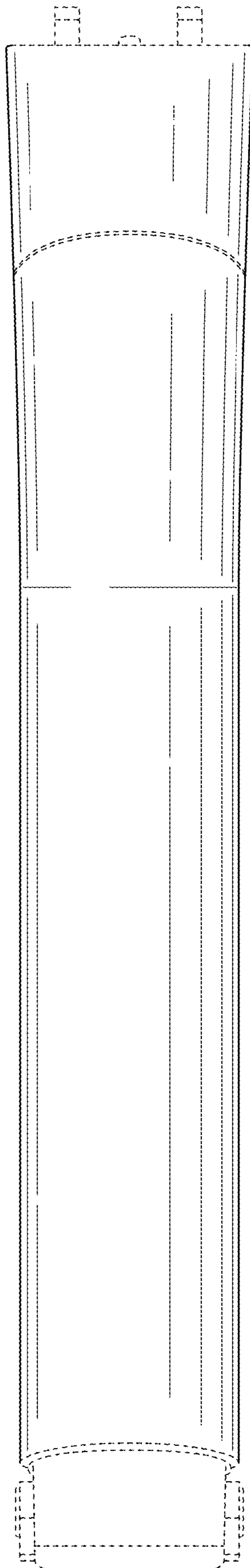

FIG. 6

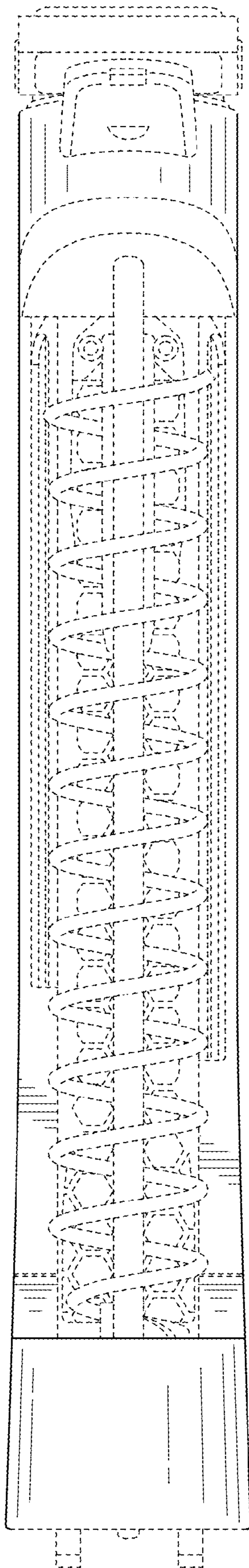

FIG. 7

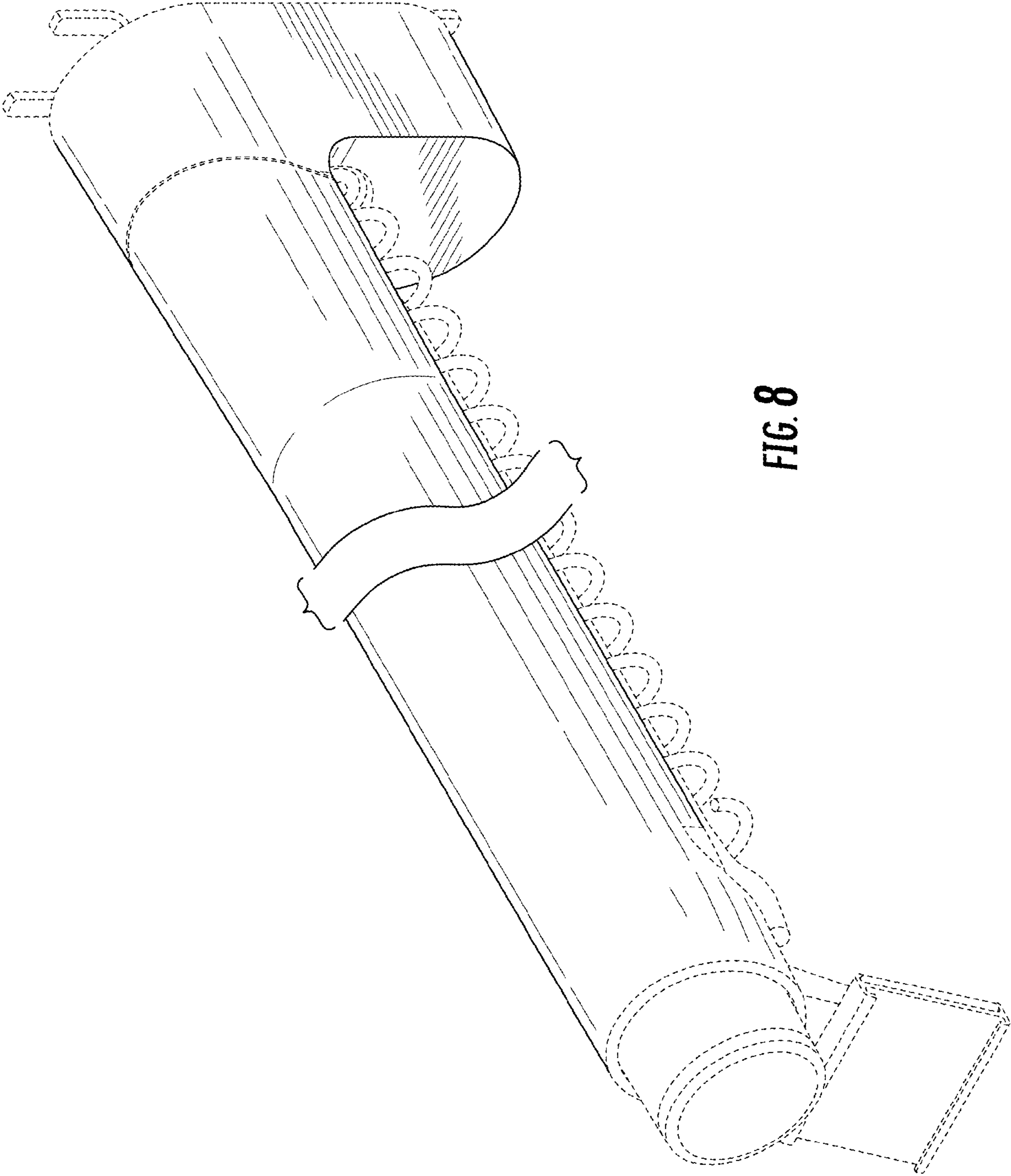

FIG. 8

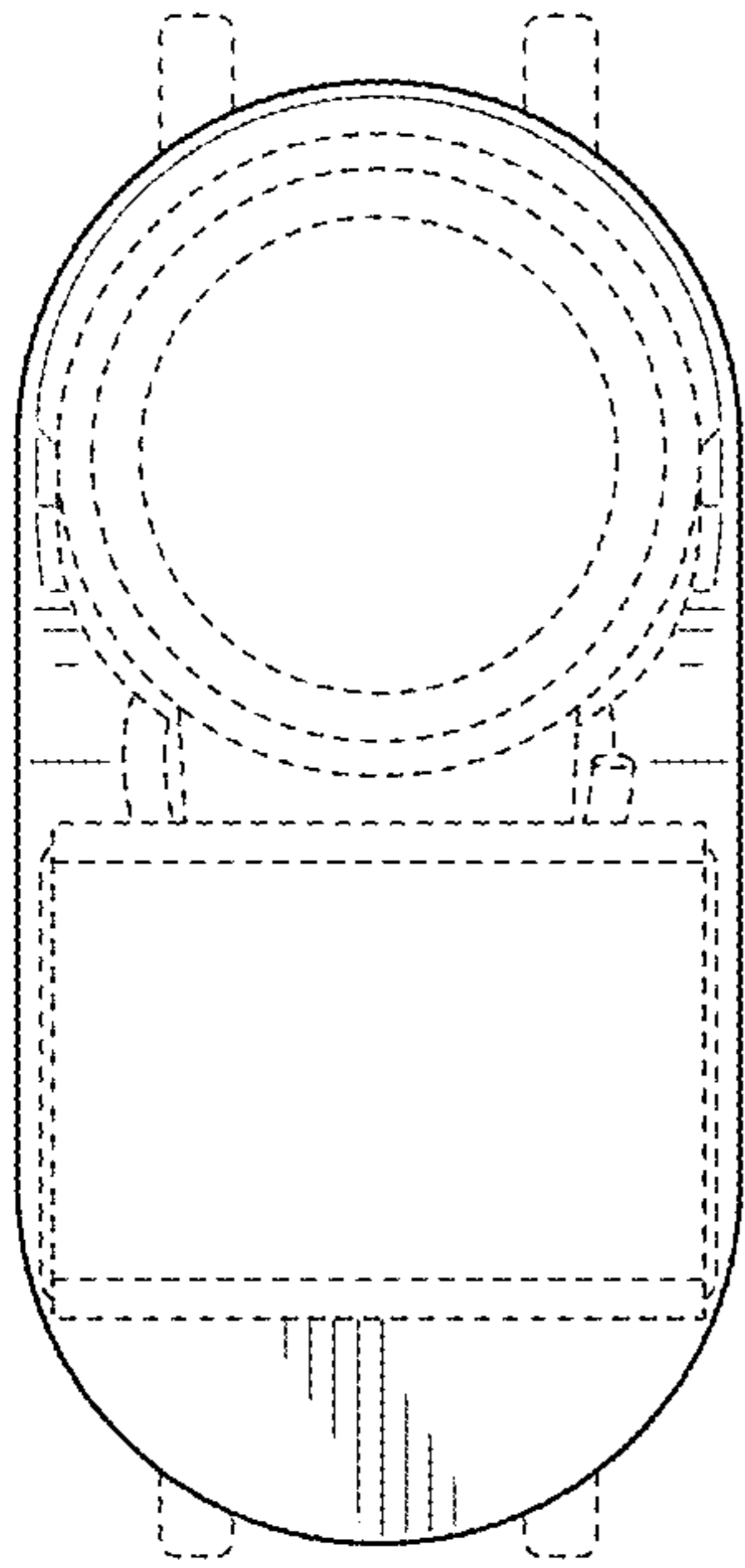

FIG. 9

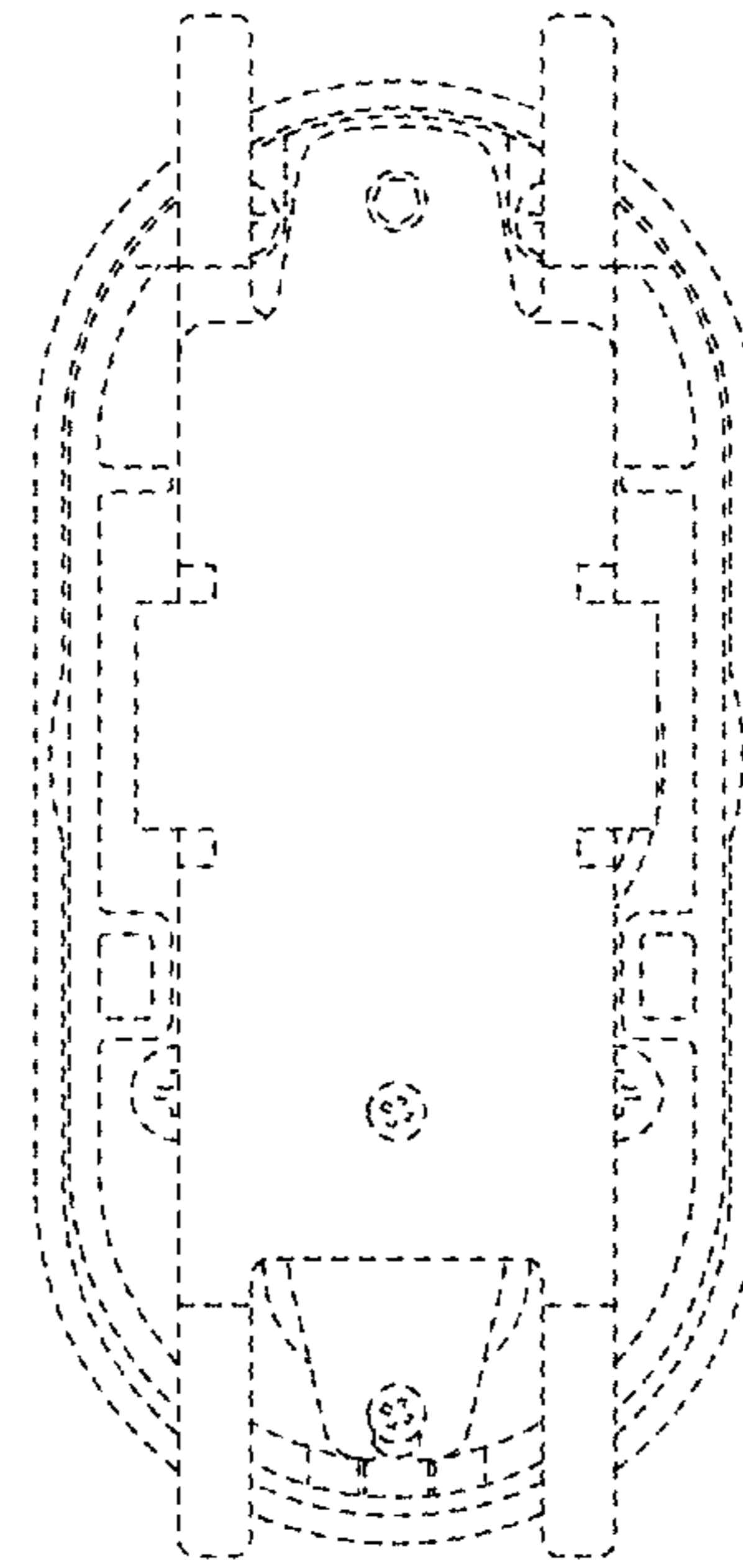

FIG. 10

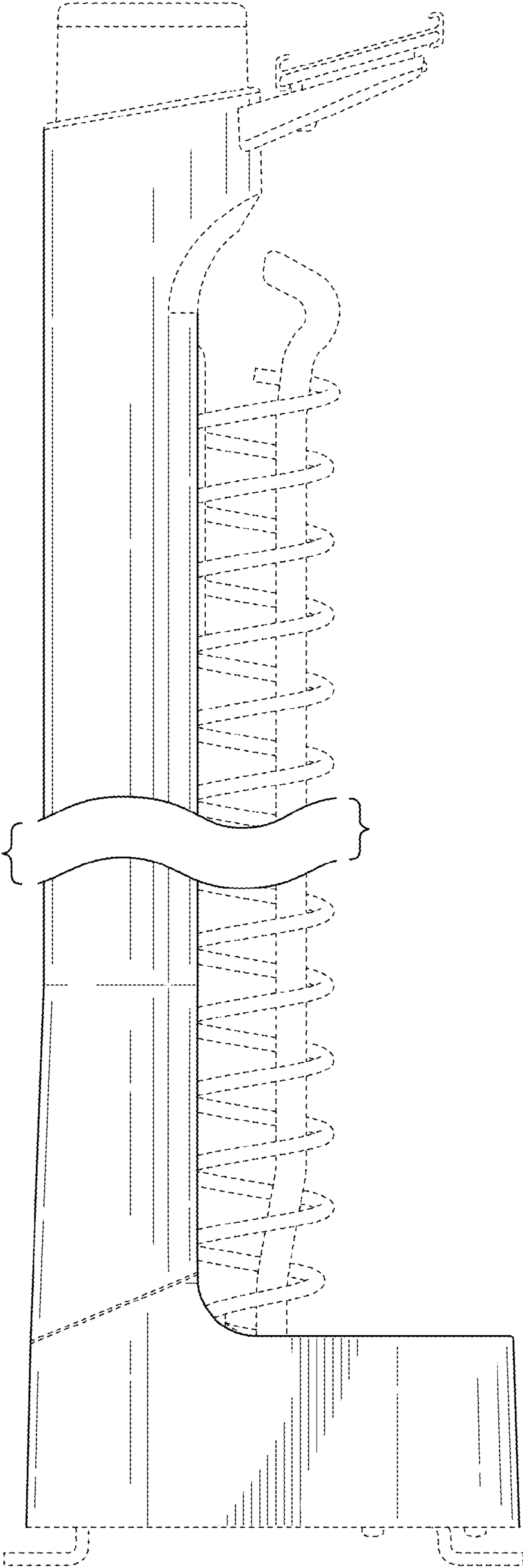

FIG. 11

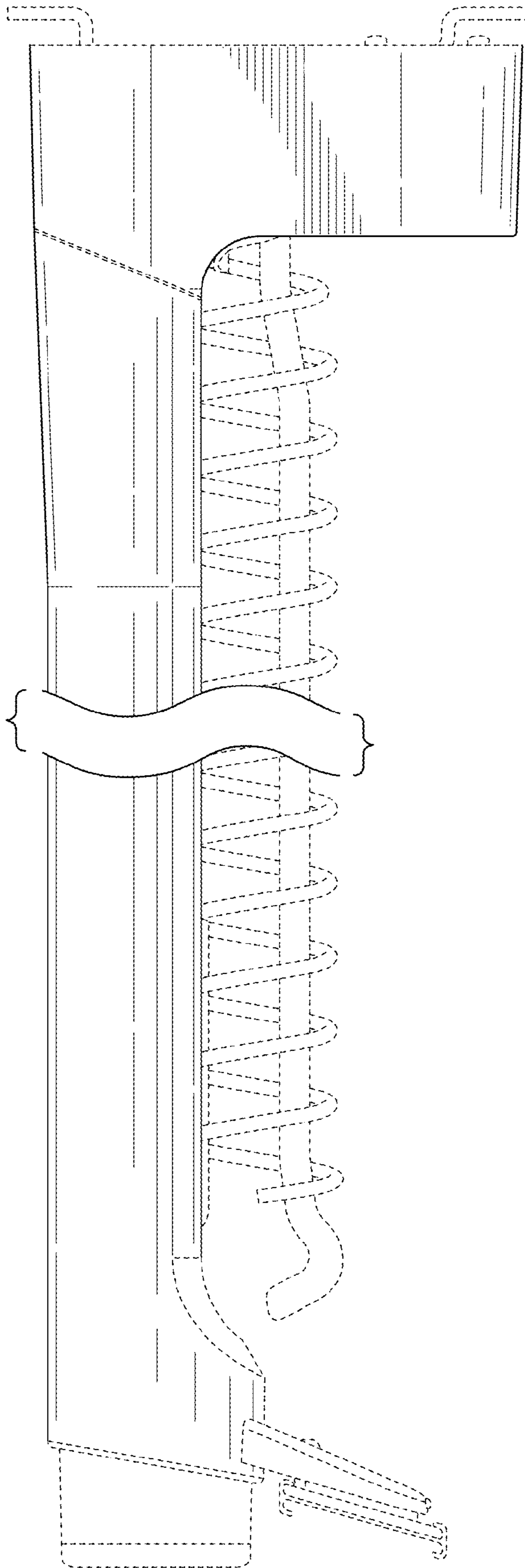

FIG. 12

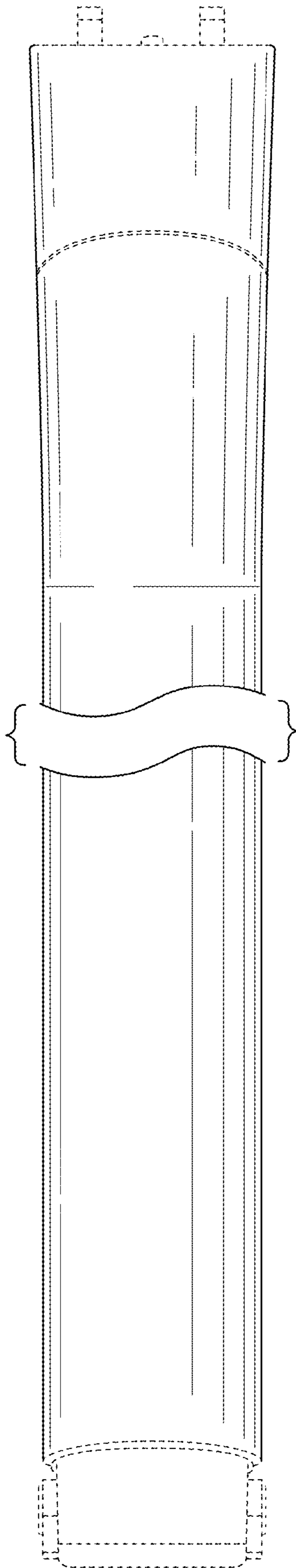

FIG. 13

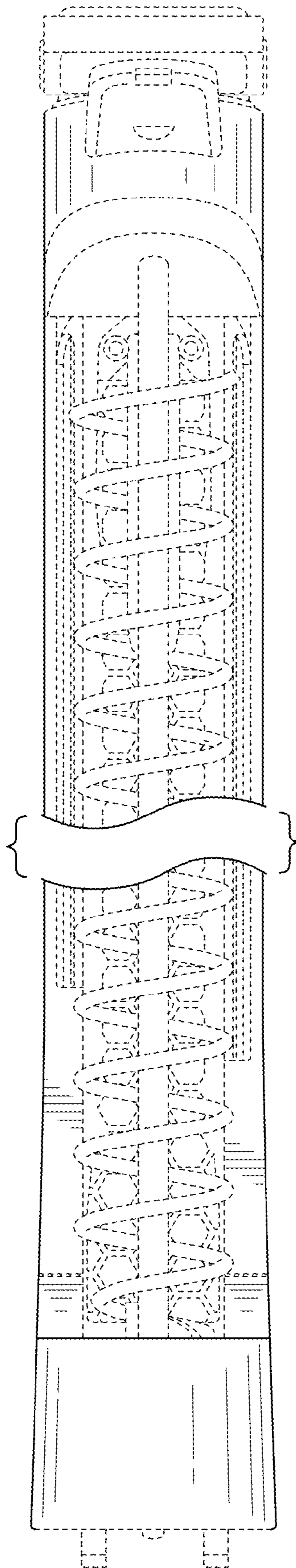

FIG. 14