



US00D921060S

(12) **United States Design Patent** (10) **Patent No.:** **US D921,060 S**
Römer et al. (45) **Date of Patent:** **** Jun. 1, 2021**

(54) **ROAD ROLLER CAB**
(71) Applicant: **HAMM AG**, Tirschenreuth (DE)
(72) Inventors: **Axel Römer**, Tirschenreuth (DE);
Ulrich Ewringmann, Pöcking (DE);
Stefan Reber, Weiden (DE); **Markus**
Beese, Munich (DE); **Thomas Häring**,
Mähring (DE); **Gernot Reif**, Buckenhof
(DE); **Gerd Köstler**, Tirschenreuth
(DE)
(73) Assignee: **HAMM AG**, Tirschenreuth (DE)
(**) Term: **15 Years**
(21) Appl. No.: **29/686,501**
(22) Filed: **Apr. 4, 2019**
(51) **LOC (13) Cl.** **15-03**
(52) **U.S. Cl.**
USPC **D15/30**
(58) **Field of Classification Search**
USPC D15/10, 22-26, 28, 30; 180/89.1, 89.12,
180/89.13, 900, 9.1, 9.2, 9.62; 37/379;
414/694, 699, 722-724, 660, 685, 698,
414/719, 743
CPC E02F 3/32; E02F 3/76; E02F 3/40; E02F
3/325; E02F 3/352; E02F 3/384; E02F
3/425; E02F 3/437; E02F 3/627; E02F
3/964; E02F 9/163; E02F 9/0858; E02F
9/0875; E02F 9/2045; E02F 9/006; E02F
9/0808; E02F 9/0833; E02F 9/2004; E02F
9/207; E02F 9/2091; E02F 9/2246; E02F
9/2292
See application file for complete search history.

D531,647 S * 11/2006 Stender D15/30
D541,825 S * 5/2007 Pettersson D15/30
D561,205 S * 2/2008 Pettersson D15/30
D579,028 S * 10/2008 VanDeVeer D15/30
D589,067 S 3/2009 Yamamoto
D605,207 S * 12/2009 Menges D15/30
D611,505 S 3/2010 Loew et al.
D611,506 S 3/2010 Loew et al.
D657,397 S 4/2012 Loew
D660,881 S * 5/2012 Bohme D15/30
D667,851 S * 9/2012 Warr D15/30
D670,745 S * 11/2012 Warr D15/30
D671,566 S * 11/2012 Fang D15/30
8,376,655 B2 2/2013 Marsolek et al.
D687,868 S * 8/2013 Watson D15/30
D694,278 S 11/2013 Ewringmann
D694,279 S 11/2013 Ewringmann
D699,764 S 2/2014 Loew et al.
D744,543 S 12/2015 Loew et al.
D745,063 S 12/2015 Loew et al.
D749,142 S 2/2016 Erdmann et al.

(Continued)

Primary Examiner — Mark A Goodwin
(74) *Attorney, Agent, or Firm* — Greer, Burns & Crain,
Ltd.

(57) **CLAIM**

The ornamental design for the road roller cab, as shown and described.

DESCRIPTION

FIG. 1 is a top perspective view of a road roller cab showing our new design;
FIG. 2 is a top rear perspective view of the road roller cab of FIG. 1;
FIG. 3 is a front view of same;
FIG. 4 is a rear view of the road roller cab of FIG. 1;
FIG. 5 is a left side view of the road roller cab of FIG. 1;
FIG. 6 is a right side view of same; and,
FIG. 7 is a top view of the road roller cab of FIG. 1.

1 Claim, 7 Drawing Sheets

(56) **References Cited**
U.S. PATENT DOCUMENTS
D396,431 S 7/1998 Lindgren et al.
D516,094 S 2/2006 Doetsch et al.

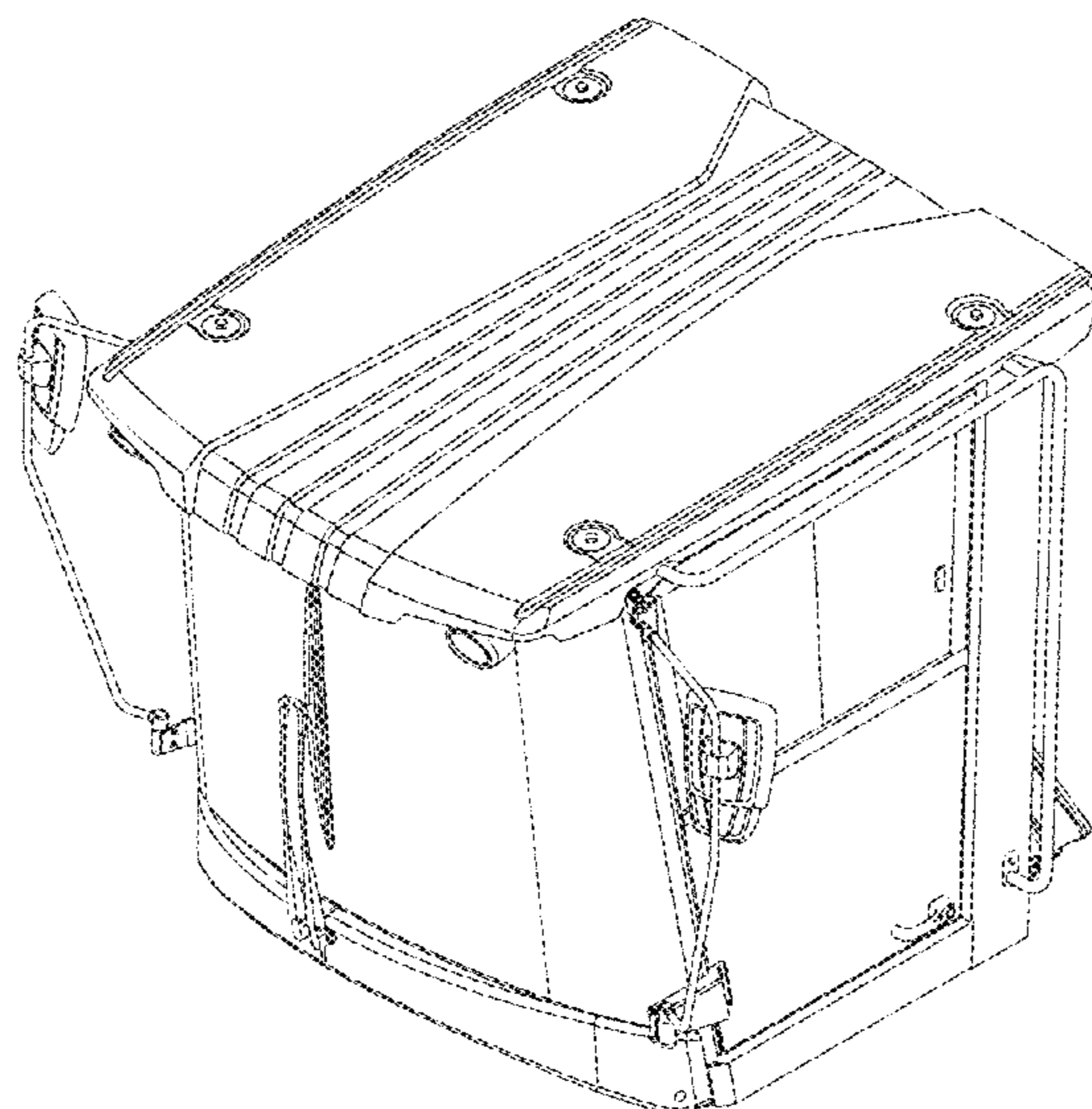

(56)

References Cited

U.S. PATENT DOCUMENTS

D749,143 S	2/2016	Erdmann et al.	
D749,148 S *	2/2016	Darekar	D15/30
D749,149 S *	2/2016	McAdam	D15/30
D765,735 S	9/2016	Roemer et al.	
D789,424 S	6/2017	Roemer et al.	
D871,462 S *	12/2019	Svitek	D15/30
D874,524 S *	2/2020	Iwata	D15/30
D877,209 S *	3/2020	Winkel	D15/30

* cited by examiner

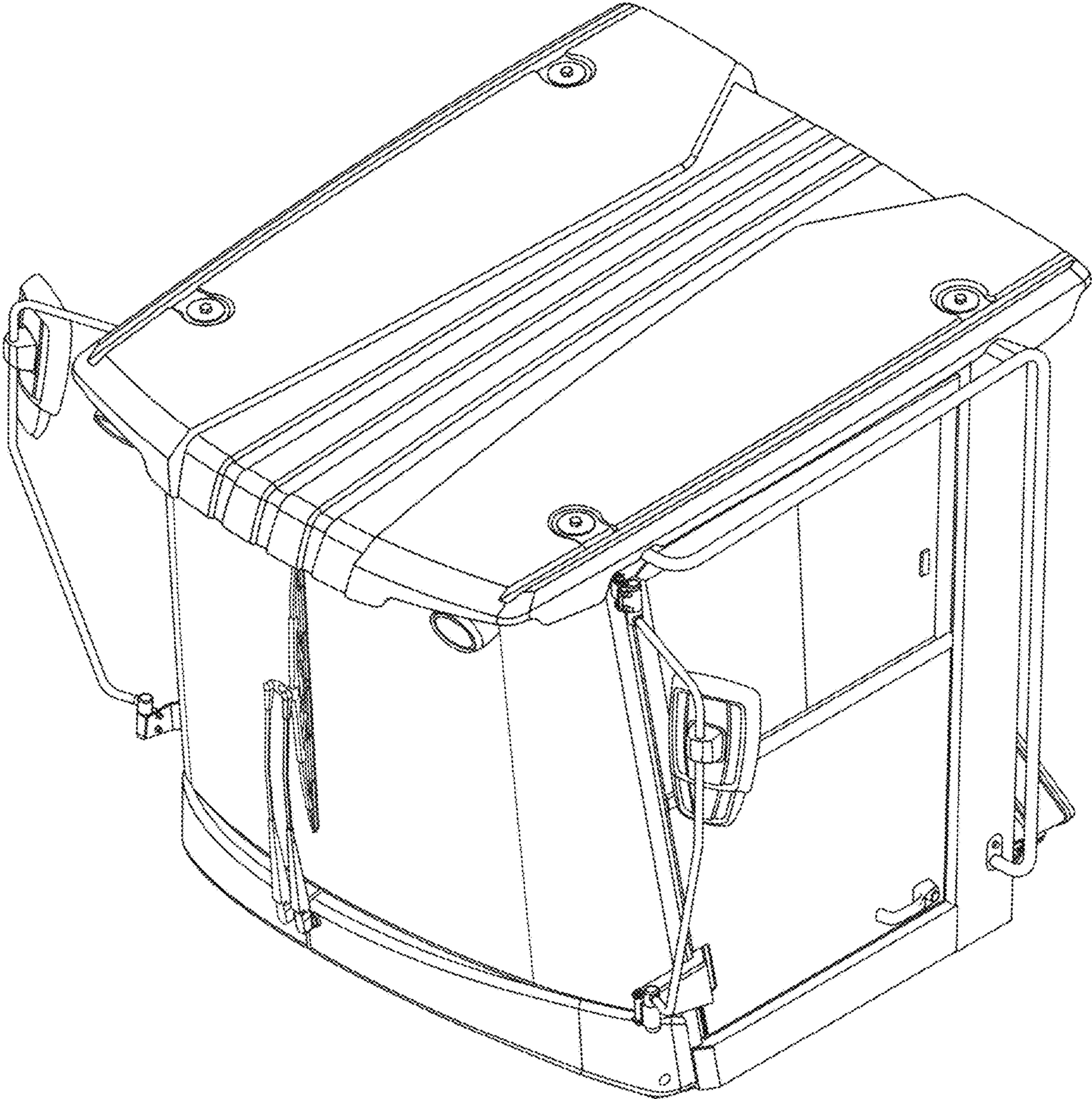

FIG. 1

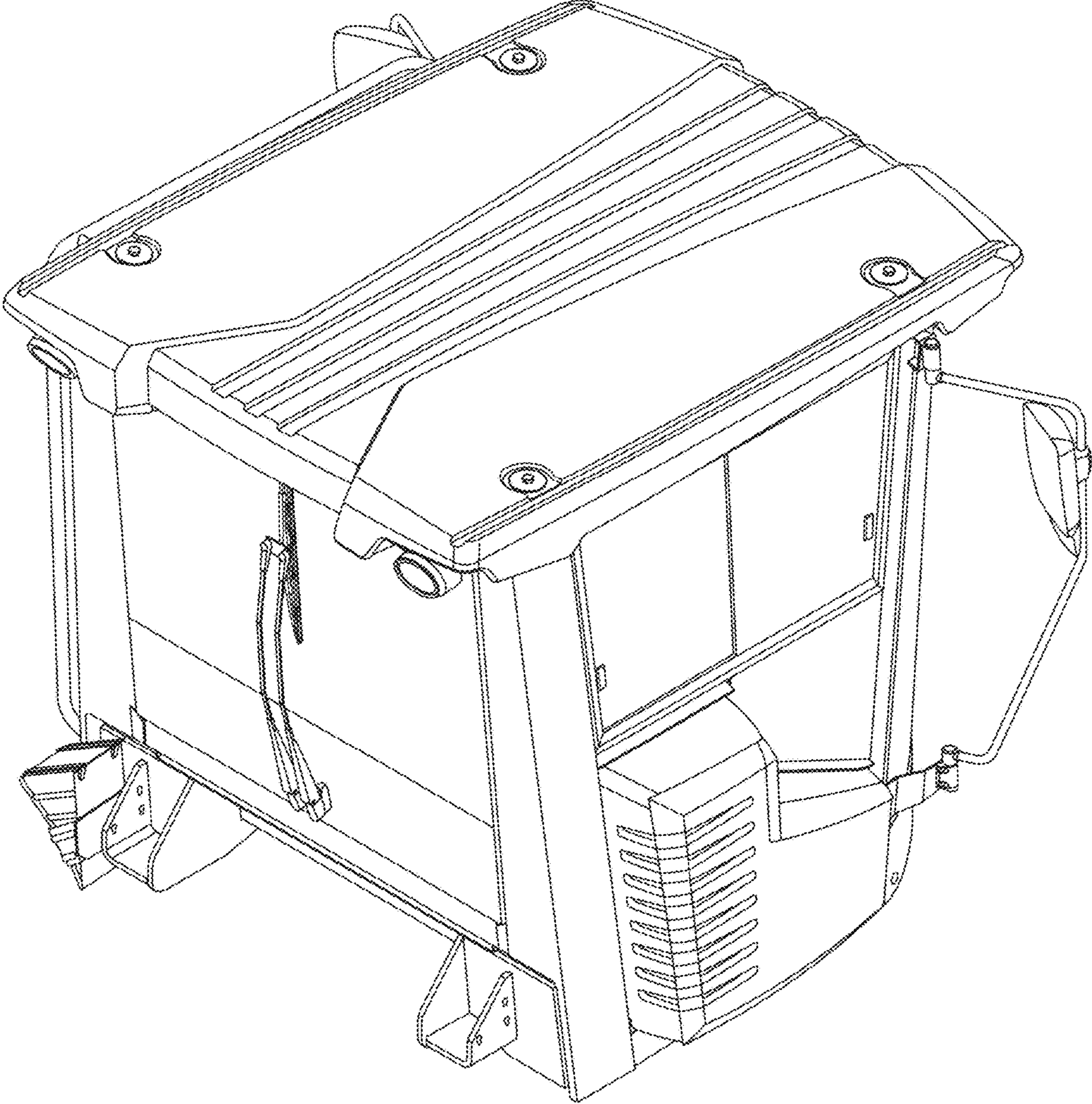

FIG. 2

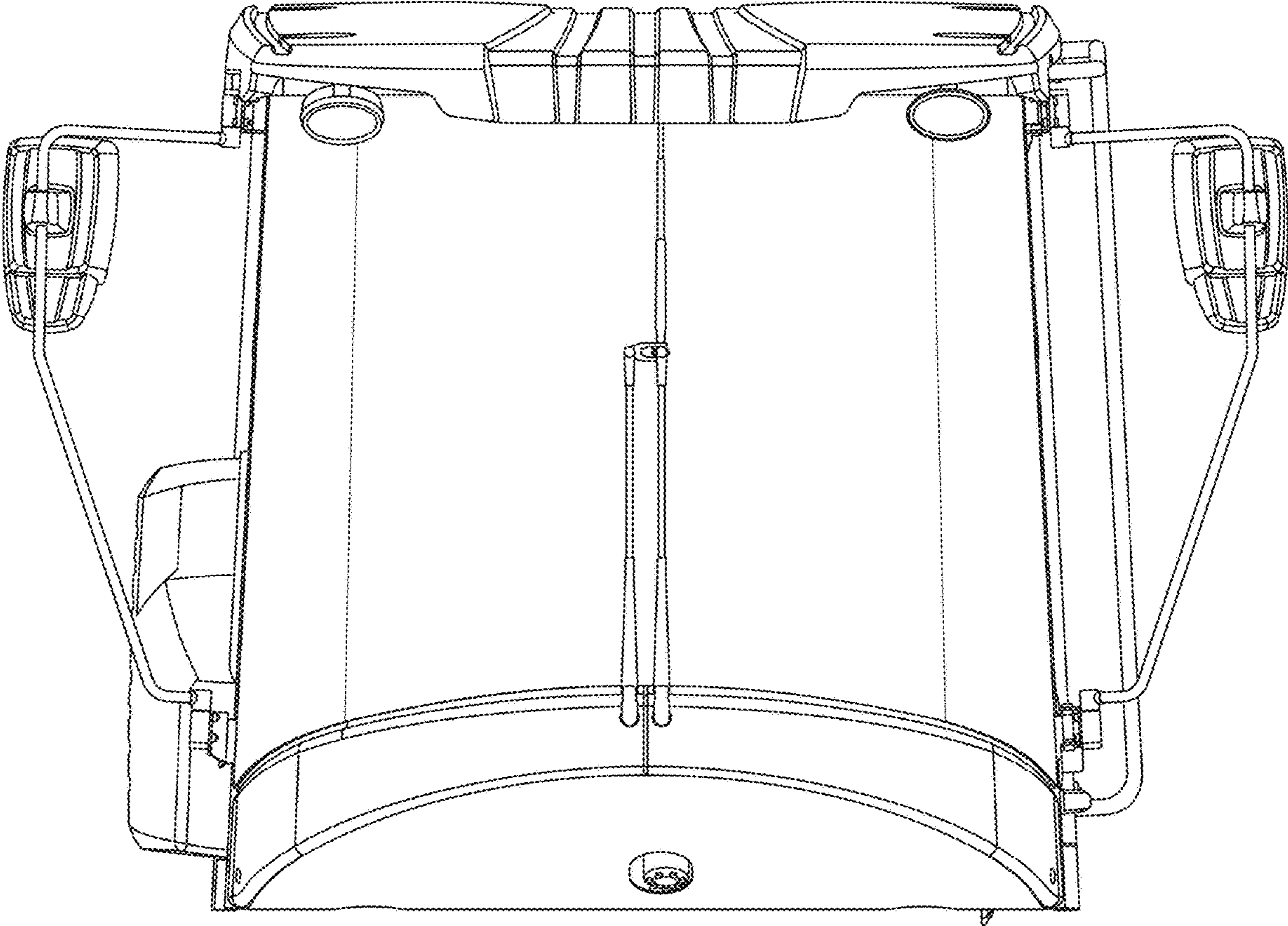

FIG. 3

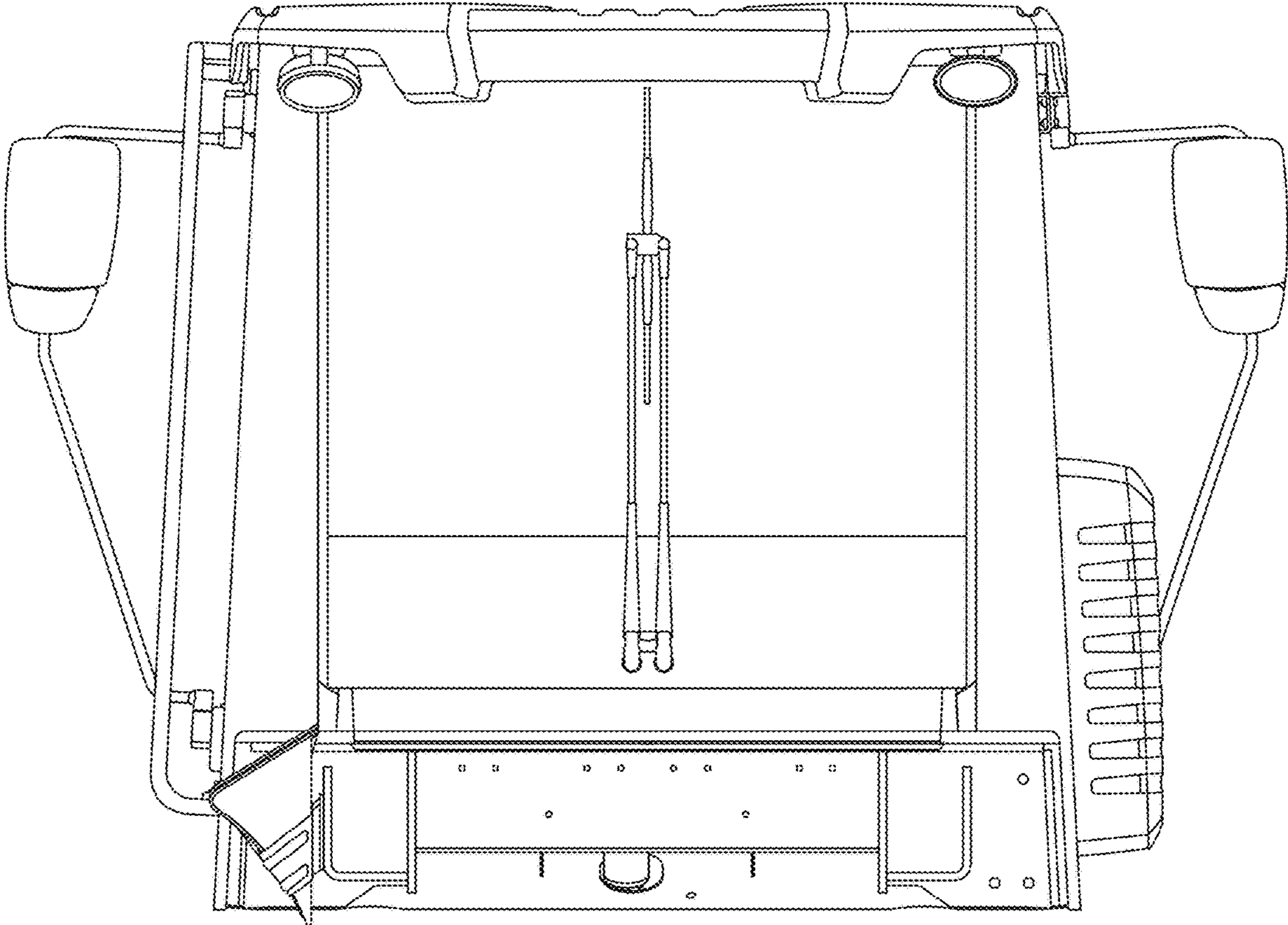

FIG. 4

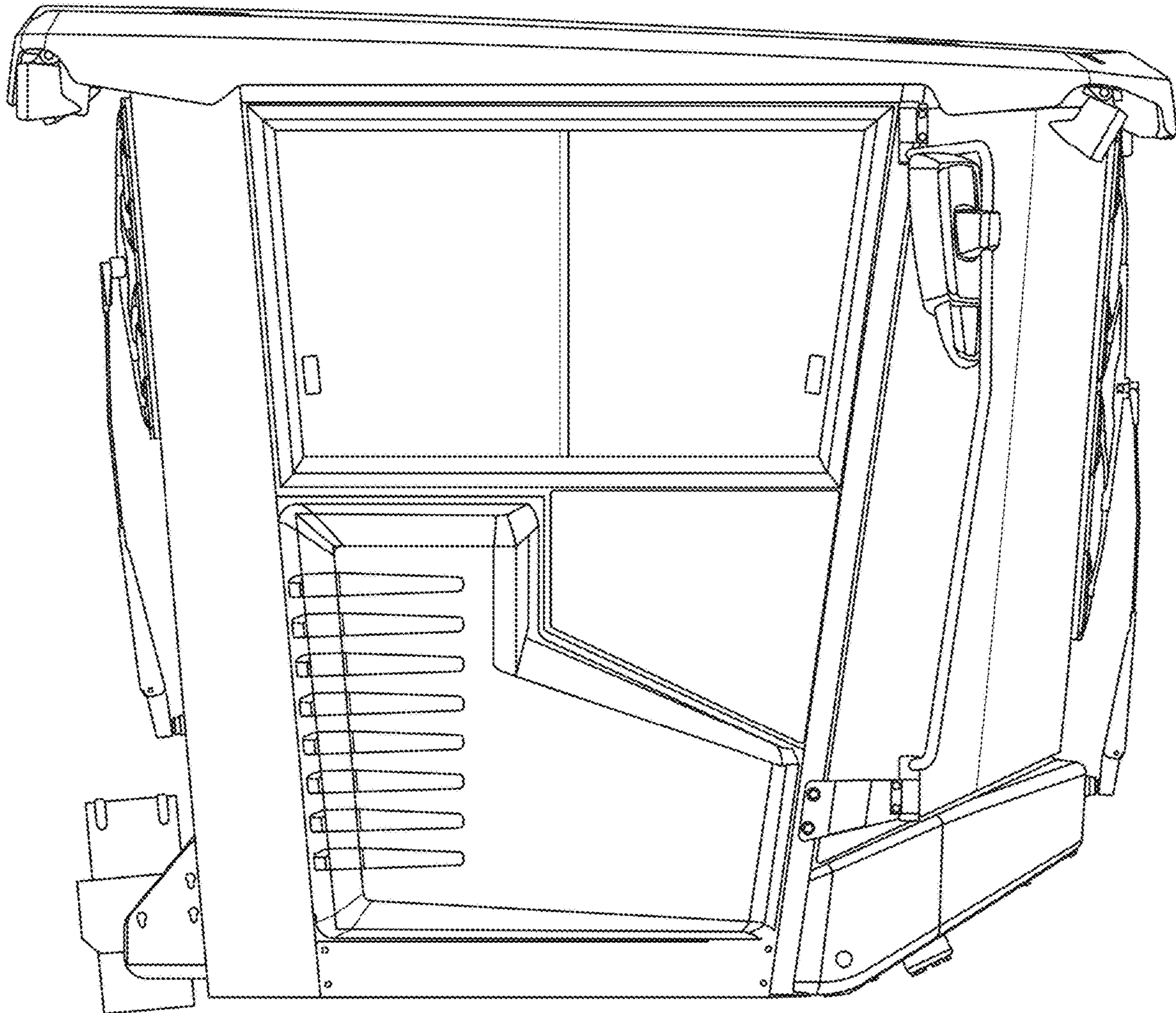

FIG. 5

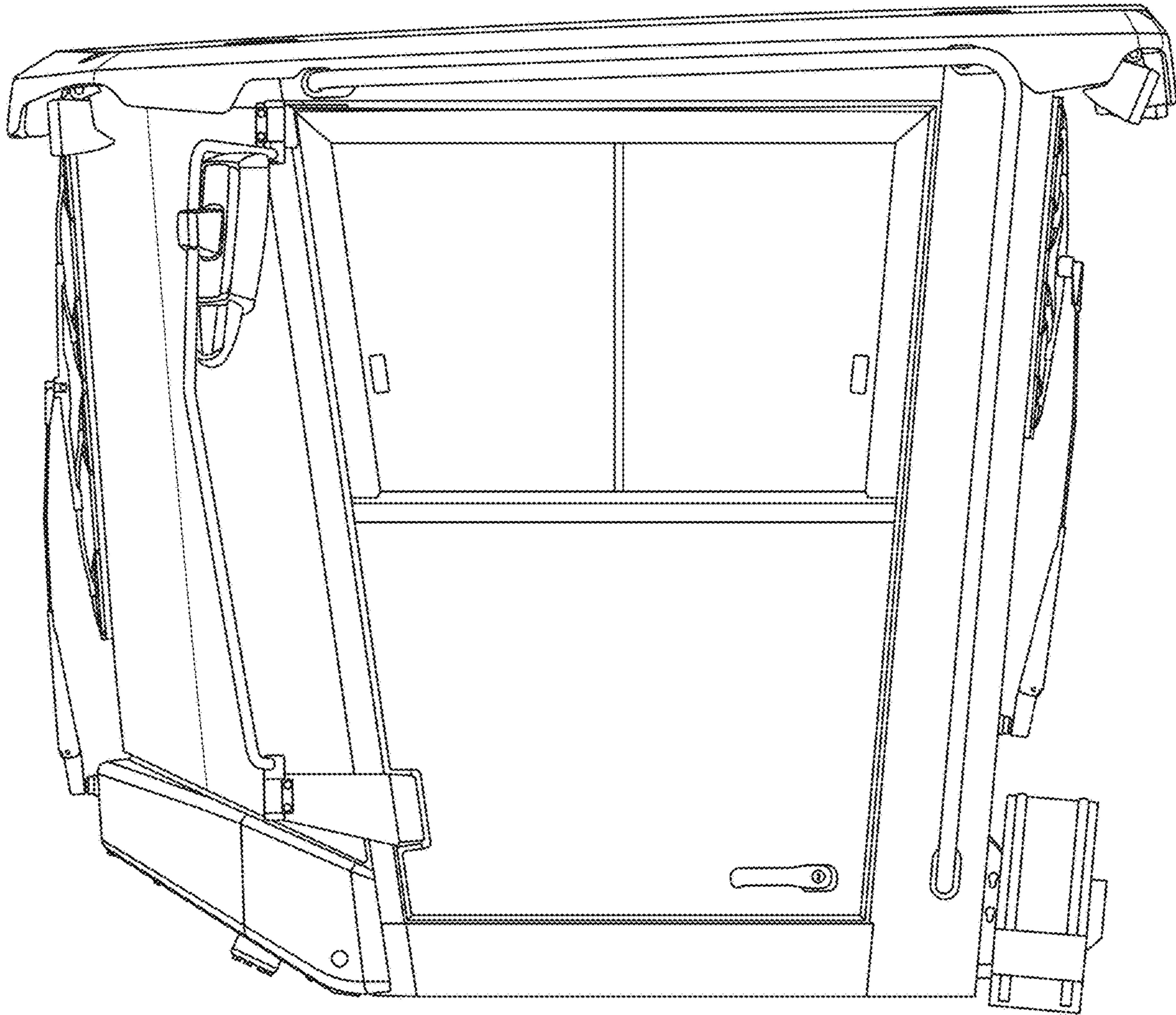

FIG. 6

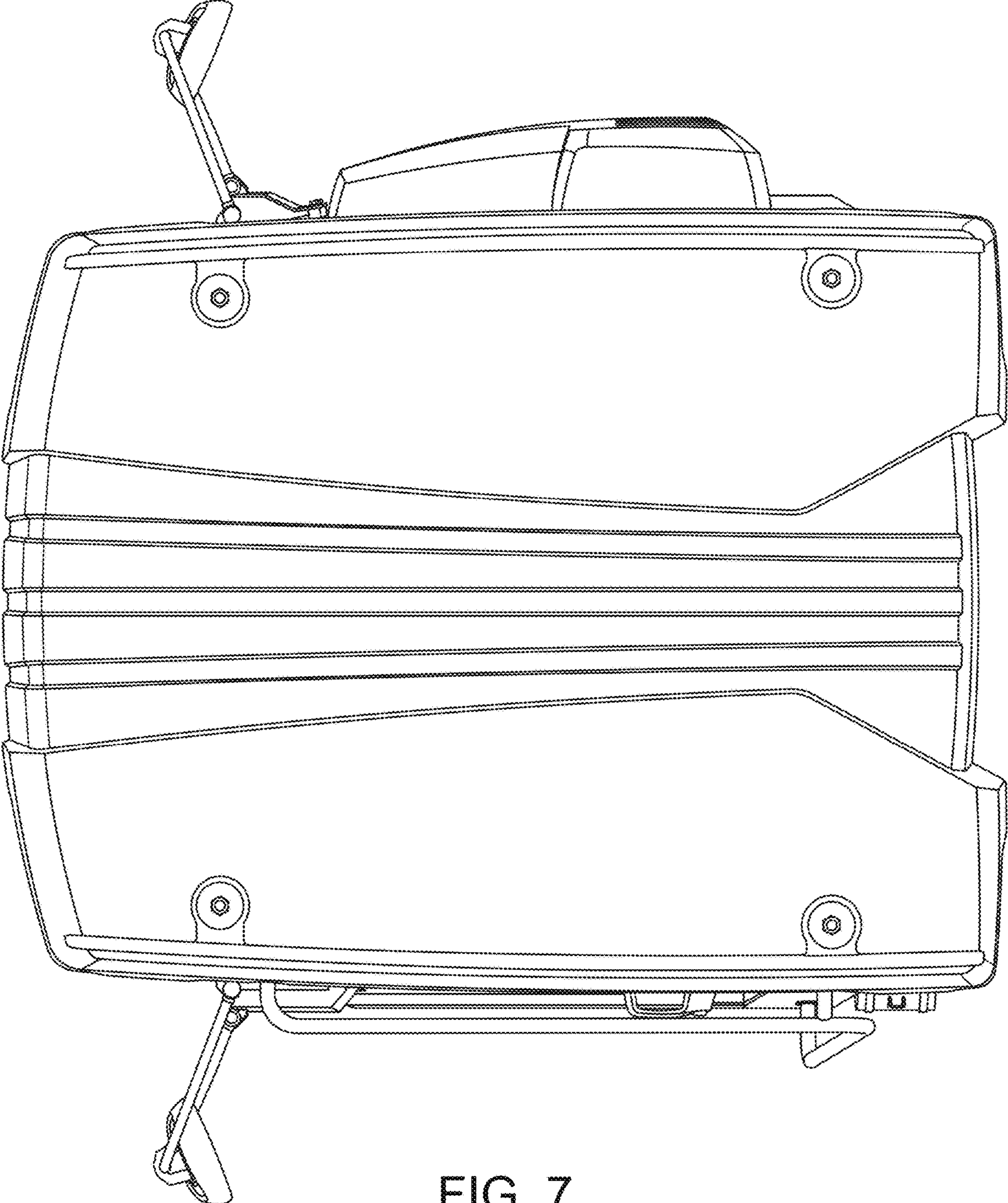

FIG. 7