



US00D920914S

(12) **United States Design Patent** (10) **Patent No.:** **US D920,914 S**
Largent et al. (45) **Date of Patent:** **** Jun. 1, 2021**

(54) **MOTOR AIR SCOOP**

search/965ea714200a4382fea974a915213e31b0add203?sort=crawl_date&order=asc&page=1&ia=ebay.com. (Year: 2015).*

(71) Applicant: **Nidec Motor Corporation**, St. Louis, MO (US)

(Continued)

(72) Inventors: **Michael L. Largent**, O'Fallon, IL (US); **Steven R. Palmer**, Highland, IL (US); **Jeffrey Scott Sherman**, Creve Coeur, MO (US)

Primary Examiner — Catherine S Posthauer

Assistant Examiner — Amanda Christensen

(74) *Attorney, Agent, or Firm* — Hovey Williams LLP

(73) Assignee: **NIDEC MOTOR CORPORATION**, St. Louis, MO (US)

(57) **CLAIM**

The ornamental design for a motor air scoop, as shown and described.

(**) Term: **15 Years**

DESCRIPTION

(21) Appl. No.: **29/696,823**

(22) Filed: **Jul. 1, 2019**

(51) **LOC (13) Cl.** **13-01**

(52) **U.S. Cl.**
USPC **D13/122; D23/412**

(58) **Field of Classification Search**
USPC D13/103, 107, 108, 110, 112, 113, 114, D13/117, 118, 119, 122, 156, 184, 199; D12/173, 180, 181, 191; D15/1, 5; D23/370, 411, 412

CPC H02K 11/00; H02K 15/028; F16D 3/84
See application file for complete search history.

This application is being filed contemporaneously with U.S. Nonprovisional application Ser. No. 16/459,244 entitled Heatsink Clamp for Multiple Electronic Components, U.S. Nonprovisional application Ser. No. 16/459,204 Entitled Motor Controller with Inductor Mounted Transverse to Control Board, U.S. Nonprovisional application Ser. No. 16/459,265 entitled Motor Fan and Guard for Directing Coolant Air, and U.S. Design application Ser. No. 29/696,824 entitled Motor Controller Housing, each of which is hereby incorporated in its entirety by reference herein.

FIG. 1 is a bottom, front, right side perspective view of a motor air scoop, showing our new design in a condition of use;

FIG. 2 is a top, front, left side perspective view of the motor air scoop of FIG. 1;

FIG. 3 is a top, front, right side perspective view thereof;

FIG. 4 is a front elevation view thereof;

FIG. 5 is a left side elevation view thereof;

FIG. 6 is a right side elevation view thereof;

FIG. 7 is a top plan view thereof; and,

FIG. 8 is a bottom plan view thereof.

In the drawings, the broken lines depict portions of the motor air scoop that form no part of the claimed design. In FIG. 1, the broken lines showing a motor depict environmental subject matter only, and form no part of the claimed design.

(56) **References Cited**

U.S. PATENT DOCUMENTS

D173,547 S * 11/1954 Sundberg D13/112
5,767,596 A * 6/1998 Stark H02K 5/00
29/596

6,091,604 A 7/2000 Plougsgaard et al.
D462,937 S * 9/2002 Nord D13/112

(Continued)

OTHER PUBLICATIONS

“Motor Plastic Fan Cover”. Found online Oct. 1, 2020 at ebay.com. Reference dated Sep. 7, 2015. Retrieved from <https://tineye.com/>

1 Claim, 7 Drawing Sheets

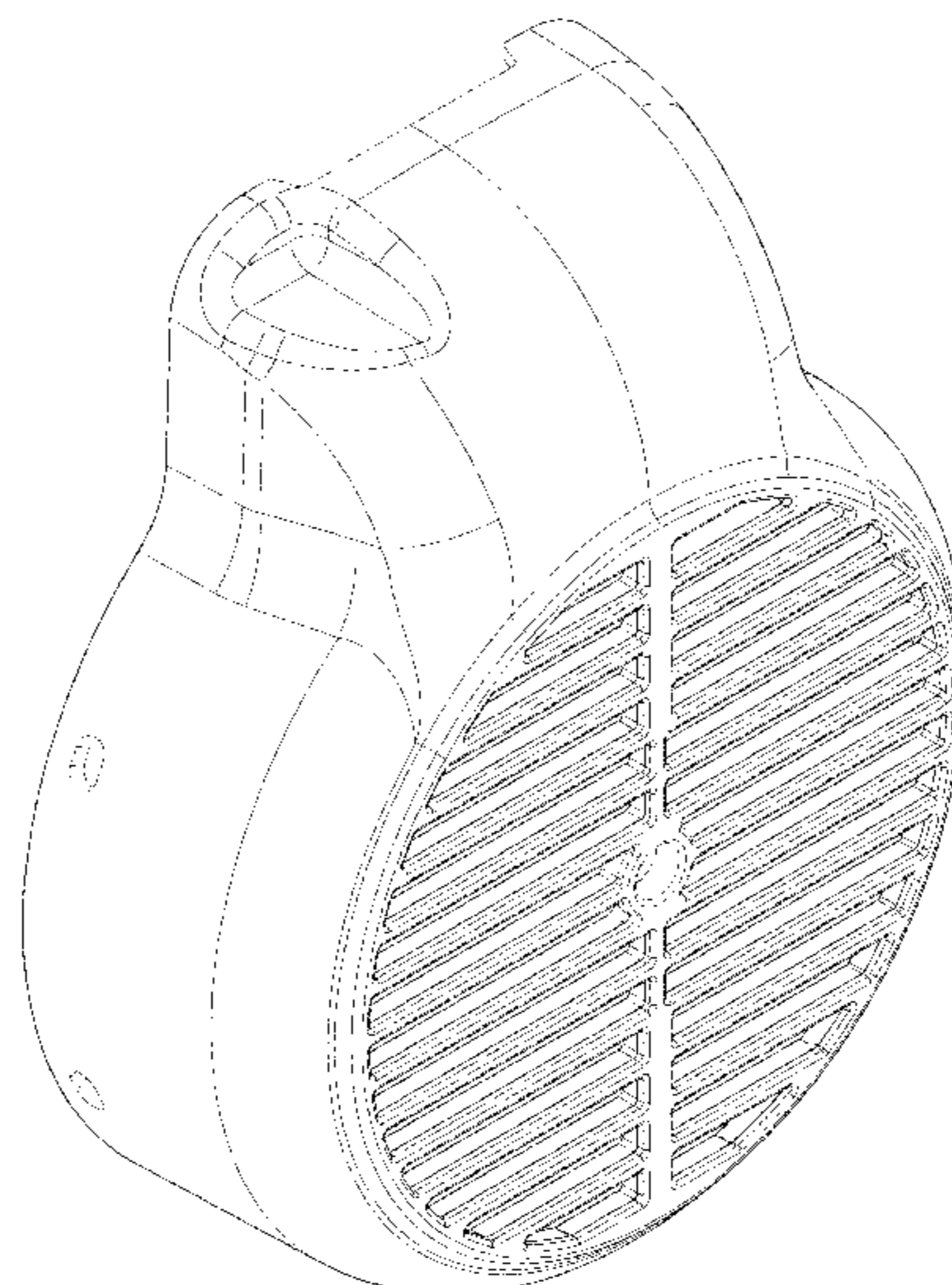

(56)

References Cited

U.S. PATENT DOCUMENTS

6,512,677 B1 1/2003 Bergherr et al.
 6,831,382 B1 12/2004 Lyle et al.
 D530,278 S 10/2006 Lyle et al.
 7,203,070 B2 4/2007 Weisz-Margulescu et al.
 D568,340 S 5/2008 Stiles, Jr. et al.
 D587,650 S * 3/2009 Lannoch D13/112
 D588,537 S * 3/2009 Allen D13/122
 D606,562 S 12/2009 Stiles, Jr. et al.
 D611,430 S 3/2010 Stiles, Jr. et al.
 7,815,420 B2 10/2010 Koehl
 7,845,913 B2 12/2010 Stiles, Jr. et al.
 7,854,597 B2 12/2010 Stiles, Jr. et al.
 7,857,600 B2 12/2010 Koehl
 7,874,808 B2 1/2011 Stiles
 7,935,888 B2 5/2011 Hansen et al.
 8,019,479 B2 9/2011 Stiles et al.
 8,043,070 B2 10/2011 Stiles, Jr. et al.
 8,313,306 B2 11/2012 Stiles, Jr. et al.
 8,363,408 B2 1/2013 Zheng
 8,465,262 B2 6/2013 Stiles, Jr. et al.
 8,469,675 B2 6/2013 Stiles, Jr. et al.
 8,480,373 B2 7/2013 Stiles, Jr. et al.
 8,500,413 B2 8/2013 Stiles, Jr. et al.
 8,573,952 B2 11/2013 Stiles, Jr. et al.
 8,602,743 B2 12/2013 Stiles, Jr. et al.
 8,602,745 B2 12/2013 Stiles, Jr. et al.
 8,801,389 B2 8/2014 Stiles, Jr. et al.
 8,840,376 B2 9/2014 Stiles, Jr. et al.

D723,154 S * 2/2015 Cheng D23/412
 9,172,283 B2 * 10/2015 Li H02K 5/02
 D772,127 S * 11/2016 Heilaneh D12/181
 D826,277 S * 8/2018 Scott D15/1
 D870,618 S * 12/2019 Cummings, IV D12/180
 D886,010 S * 6/2020 Pereira D12/181
 2014/0265433 A1 * 9/2014 Fritts B62D 35/001
 2016/0172926 A1 6/2016 Miller et al.
 2018/0001943 A1 * 1/2018 Schellekens B29C 45/0001
 296/180.2

OTHER PUBLICATIONS

“Motor Parts”. Found online Sep. 14, 2020 at facebook.com. Reference dated Jun. 15, 2016. Retrieved from <https://www.facebook.com/mpr09199835509/photos/a.1256877240998580/1256877310998573/?type=3&theater>. (Year: 2016).*

“Daimler Truck Division Announces 1200 New Jobs In USA”. Found online Sep. 16, 2015 at motoren.com. Reference dated Jan. 13, 2012. Retrieved from <https://motoren.wordpress.com/2012/01/13/daimler-truck-division-announces-1200-new-jobs-in-usa/>. (Year: 2015).*

“BALDOR External Fan Cover”. Found online Oct. 15, 2020 at electricmotorwholesale.com. Reference dated Oct. 22, 2013. Retrieved from https://tineye.com/search/8c6692370d1aaf515da1f0e3b9f4c9e0effab2f2?sort=crawl_date&order=asc&page=1. (Year: 2013).*

* cited by examiner

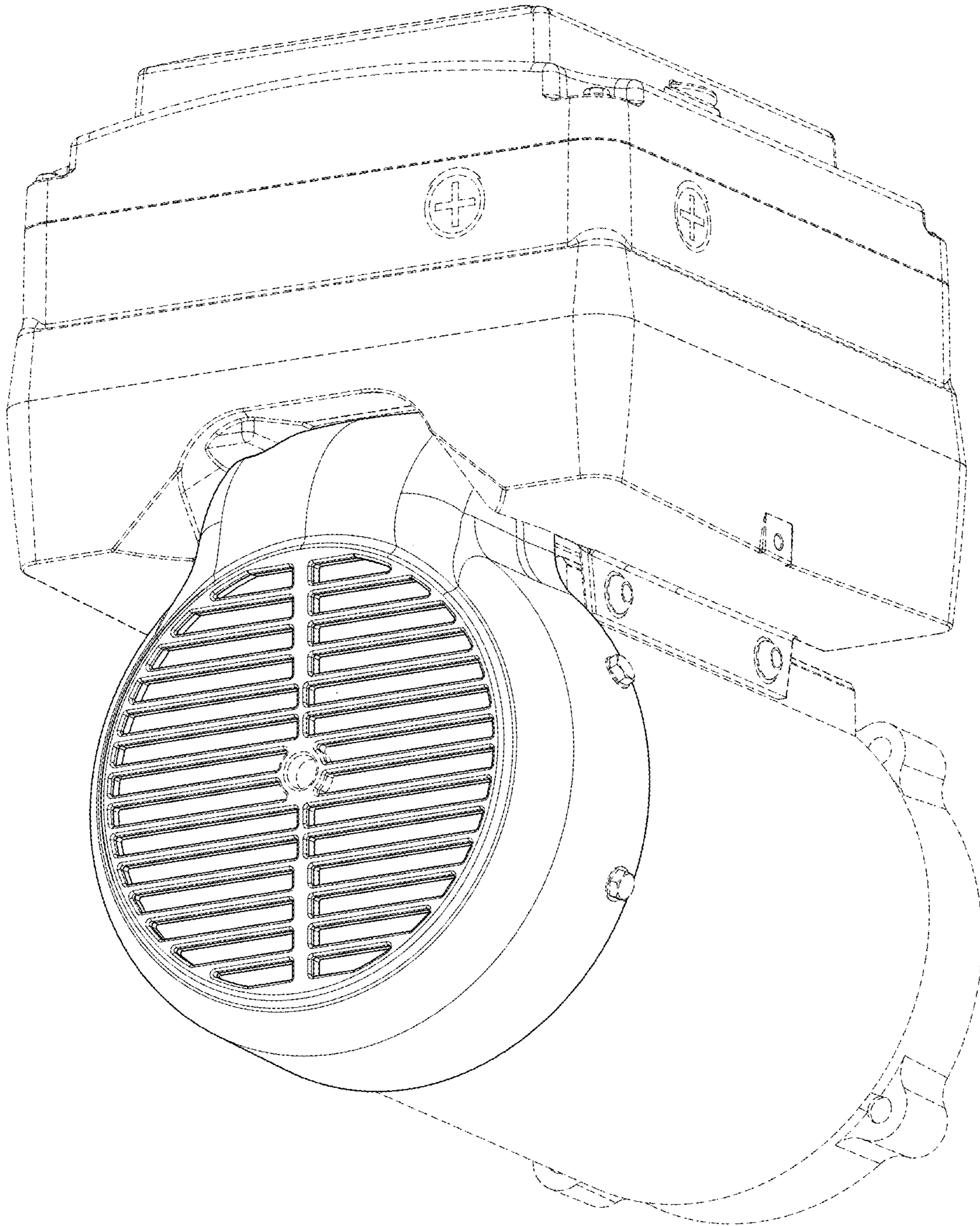

Fig. 1

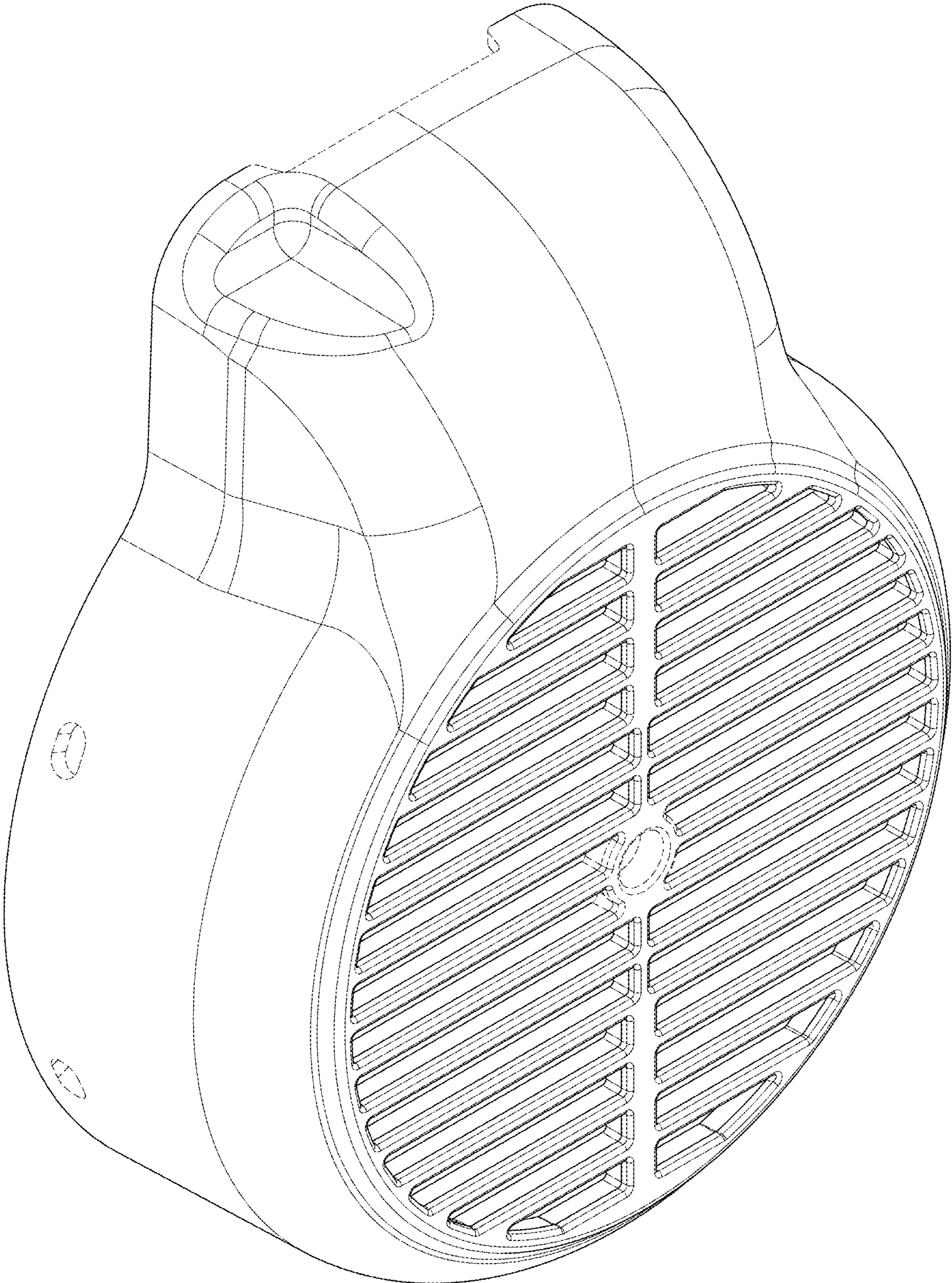

Fig. 2

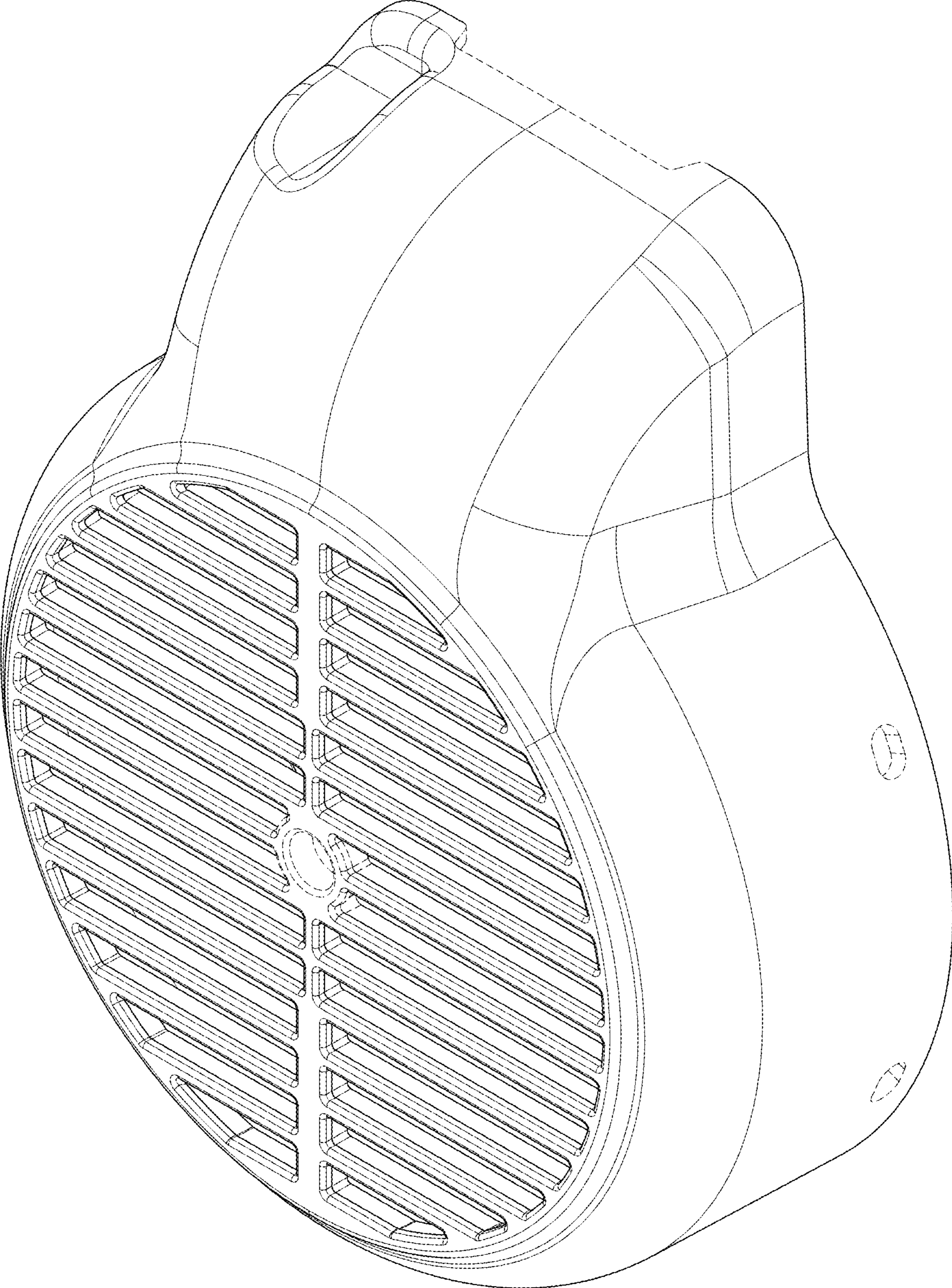

Fig. 3

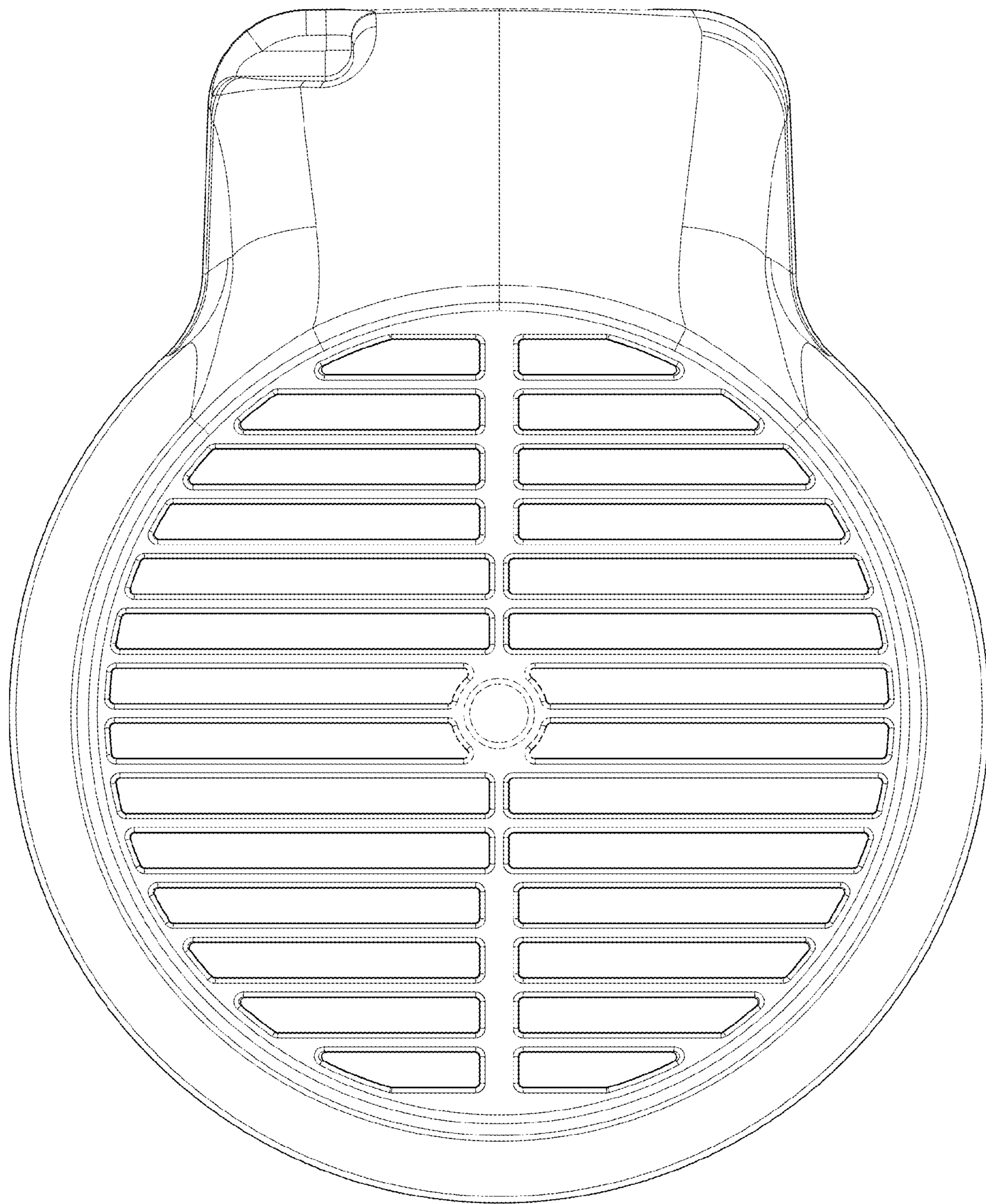

Fig. 4

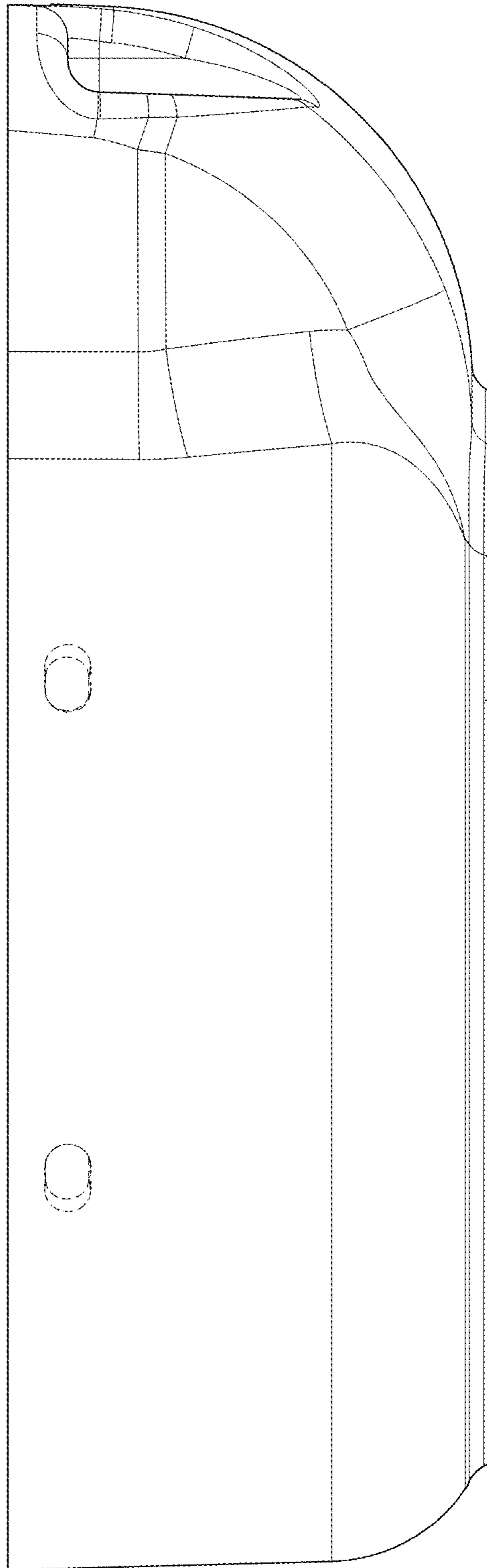

Fig. 5

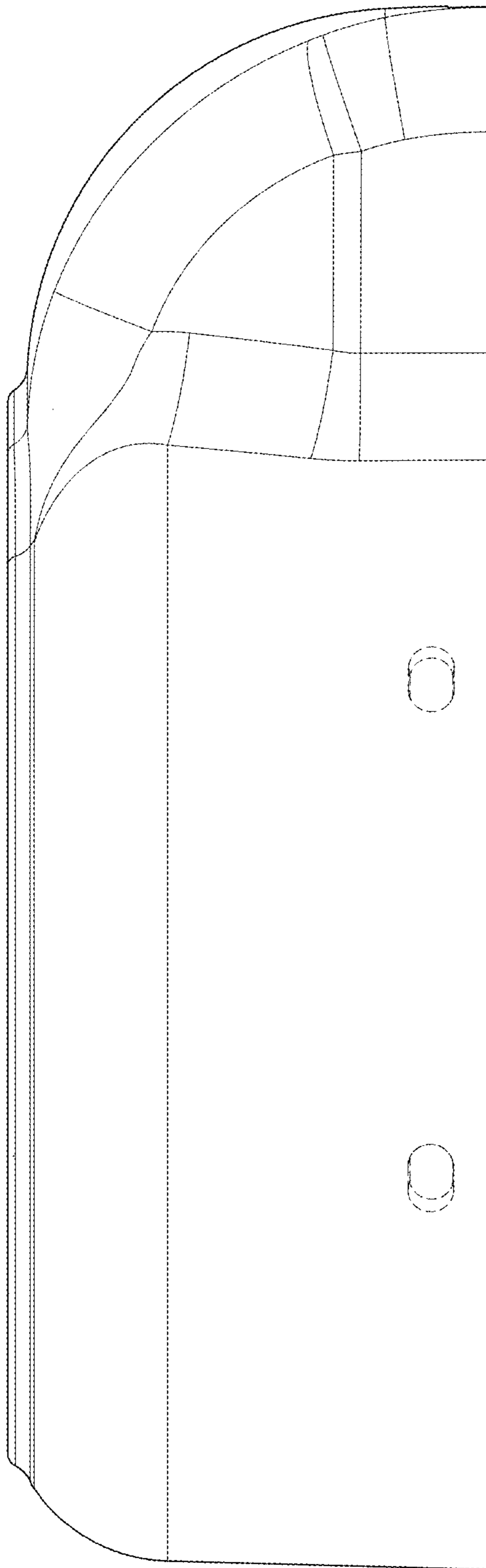

Fig. 6

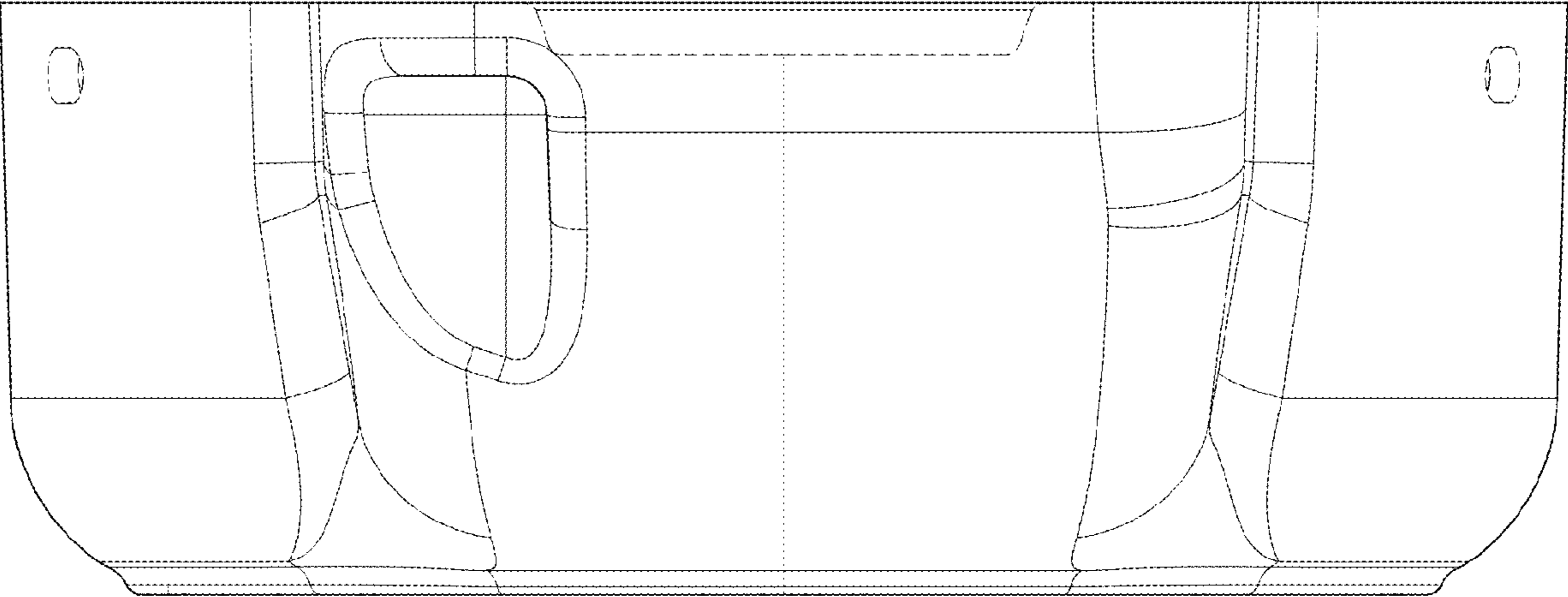

Fig. 7



Fig. 8