

US00D920855S

(12) **United States Design Patent** (10) **Patent No.:** **US D920,855 S**
Wieczorek et al. (45) **Date of Patent:** **** Jun. 1, 2021**

- (54) **LIGHTWEIGHT BOTTOM DUMP TRAILER BEAM**
- (71) Applicant: **MANAC TRAILERS USA, Inc.**, Oran, MO (US)
- (72) Inventors: **Christopher Wieczorek**, Youngstown, OH (US); **Joshua Keusenkothen**, Jackson, MO (US)
- (73) Assignee: **MANAC TRAILERS USA, INC.**, Oran, MO (US)

- D489,297 S * 5/2004 Pichan D12/162
- 7,246,833 B2 * 7/2007 Exline B60R 9/06
224/502
- D648,656 S * 11/2011 Crane D12/101
- D682,749 S * 5/2013 Lai D12/133
- D688,170 S * 8/2013 Woolever D12/162
- D707,591 S * 6/2014 Sands D12/103
- D737,178 S * 8/2015 Crane D12/101
- D779,392 S * 2/2017 Hare D12/159
- D780,643 S * 3/2017 Hare D12/159
- D783,458 S * 4/2017 Pistacchio D12/101
- D786,942 S * 5/2017 Blitterswijk D15/27

(Continued)

(**) Term: **15 Years**

(21) Appl. No.: **29/648,058**

(22) Filed: **May 17, 2018**

(51) **LOC (13) Cl.** **12-16**

(52) **U.S. Cl.**
USPC **D12/162**

(58) **Field of Classification Search**
USPC D12/159-162, 400
CPC B60D 1/36; B60D 1/363; B60D 1/366;
B60D 1/40; B60D 1/167; B60D 1/248;
B60D 1/28; B60D 1/30
See application file for complete search history.

(56) **References Cited**

U.S. PATENT DOCUMENTS

- D42,406 S * 4/1912 Trego D12/160
- D54,443 S * 2/1920 Moore D12/159
- D225,523 S * 12/1972 Nunn D12/169
- D317,743 S * 6/1991 Chambers D12/161
- D341,810 S * 11/1993 Cordia D12/162
- D369,333 S * 4/1996 Juarez D12/159
- 5,630,606 A * 5/1997 Ryan B60D 1/40
280/479.3
- D424,990 S * 5/2000 McCoy D12/162
- D475,326 S * 6/2003 Lyrstrand D12/161
- D482,991 S * 12/2003 Pancheri D12/162

OTHER PUBLICATIONS

KR-300907009, published at Orbit, publication date May 19, 2017. Site visited Jan. 14, 2020. Available from Internet. (Year: 2017).*

(Continued)

Primary Examiner — Kevin K Rudzinski
Assistant Examiner — Kathleen L Jones
(74) *Attorney, Agent, or Firm* — Bryan D. Zerhusen, Esq.; Cantor Colburn LLP

(57) **CLAIM**

The ornamental design for a lightweight bottom dump trailer beam, as shown and described.

DESCRIPTION

FIG. 1 is a perspective view of a lightweight bottom dump trailer beam;
FIG. 2 is a front view thereof;
FIG. 3 is a side view thereof; and,
FIG. 4 is a front view thereof where the lightweight bottom dump trailer beam is shown mounted on a lightweight bottom dump trailer shown in broken lines.
The broken lines illustrate environment of the article and do not form part of the claimed design.

1 Claim, 4 Drawing Sheets

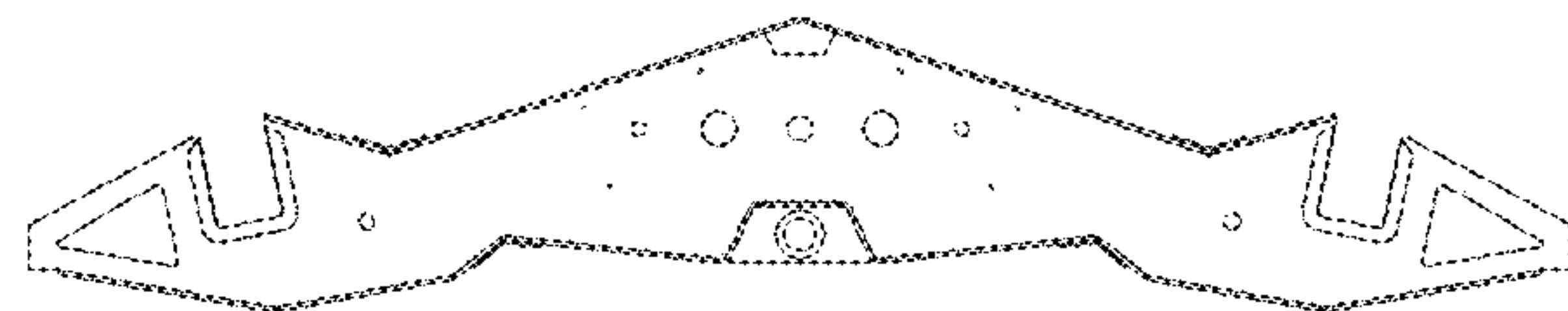
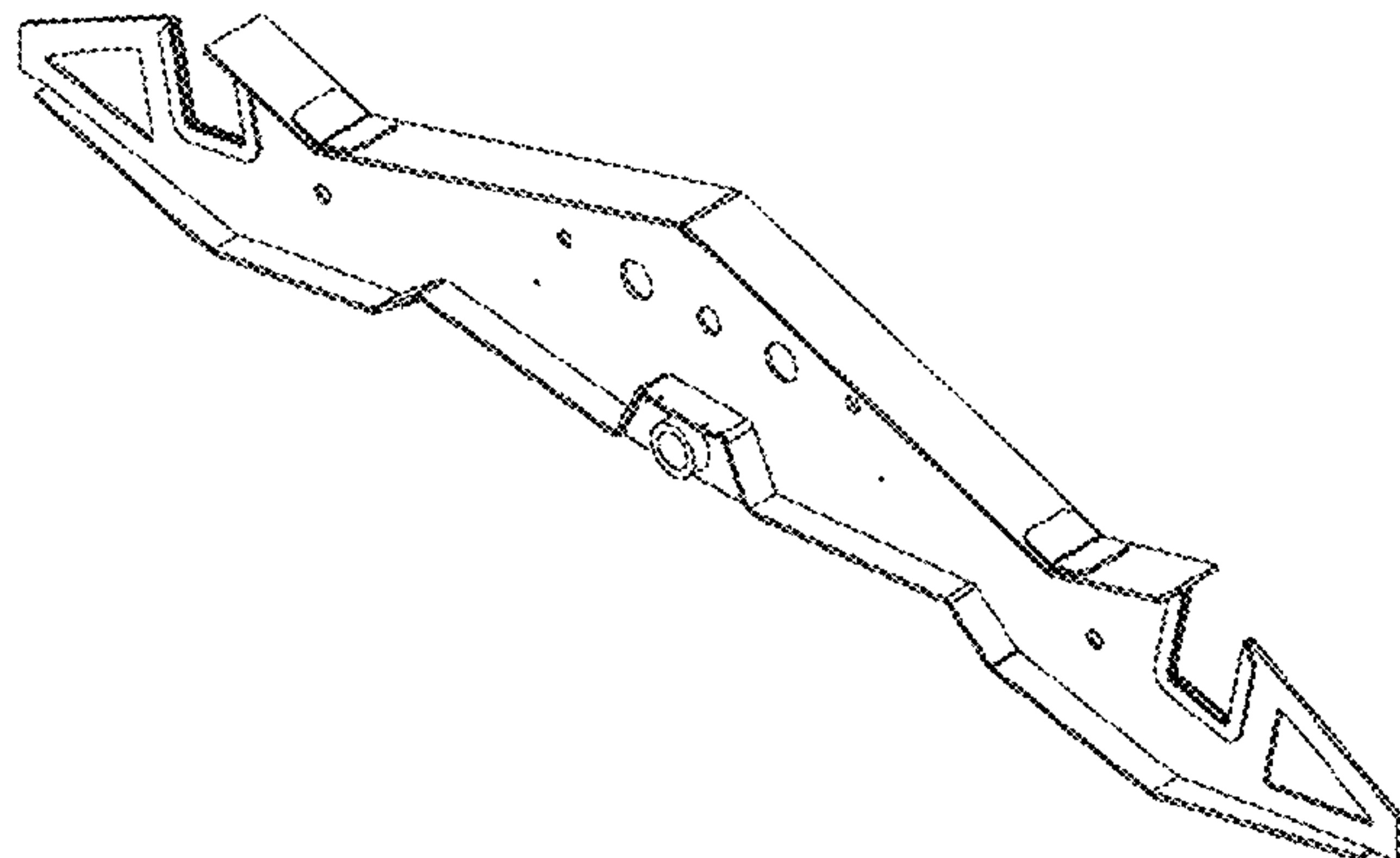

(56)

References Cited

U.S. PATENT DOCUMENTS

D828,240 S * 9/2018 Williams D12/162
D830,235 S * 10/2018 Warren D12/101
D845,175 S * 4/2019 Guenther D12/101
D856,196 S * 8/2019 Guenther D12/95
D866,683 S * 11/2019 Ewing D21/561
D880,363 S * 4/2020 Guenther D12/95
D880,374 S * 4/2020 McGaughy D12/159
2011/0198826 A1 * 8/2011 Weber B60D 1/167
280/480
2020/0094636 A1 * 3/2020 Gygi B60D 1/36

OTHER PUBLICATIONS

Belly Dump Trailers, posted at Construction Trailer Specialists, posting date Aug. 8, 2017. Site visited Jan. 9, 2020. URL: <<https://web.archive.org/web/20170808085803/http://www.constructiontrailerspecialists.com/trailers/belly-dumps>> (Year: 2017).*

Techumseh Trailers For Sale In Canada, posted at Fleet Stop Trailers, posting date Nov. 11, 2017. Site visited Jan. 9, 2020. URL: <<http://fleetstoptrailers.com/tecumseh/>> (Year: 2017).*

* cited by examiner

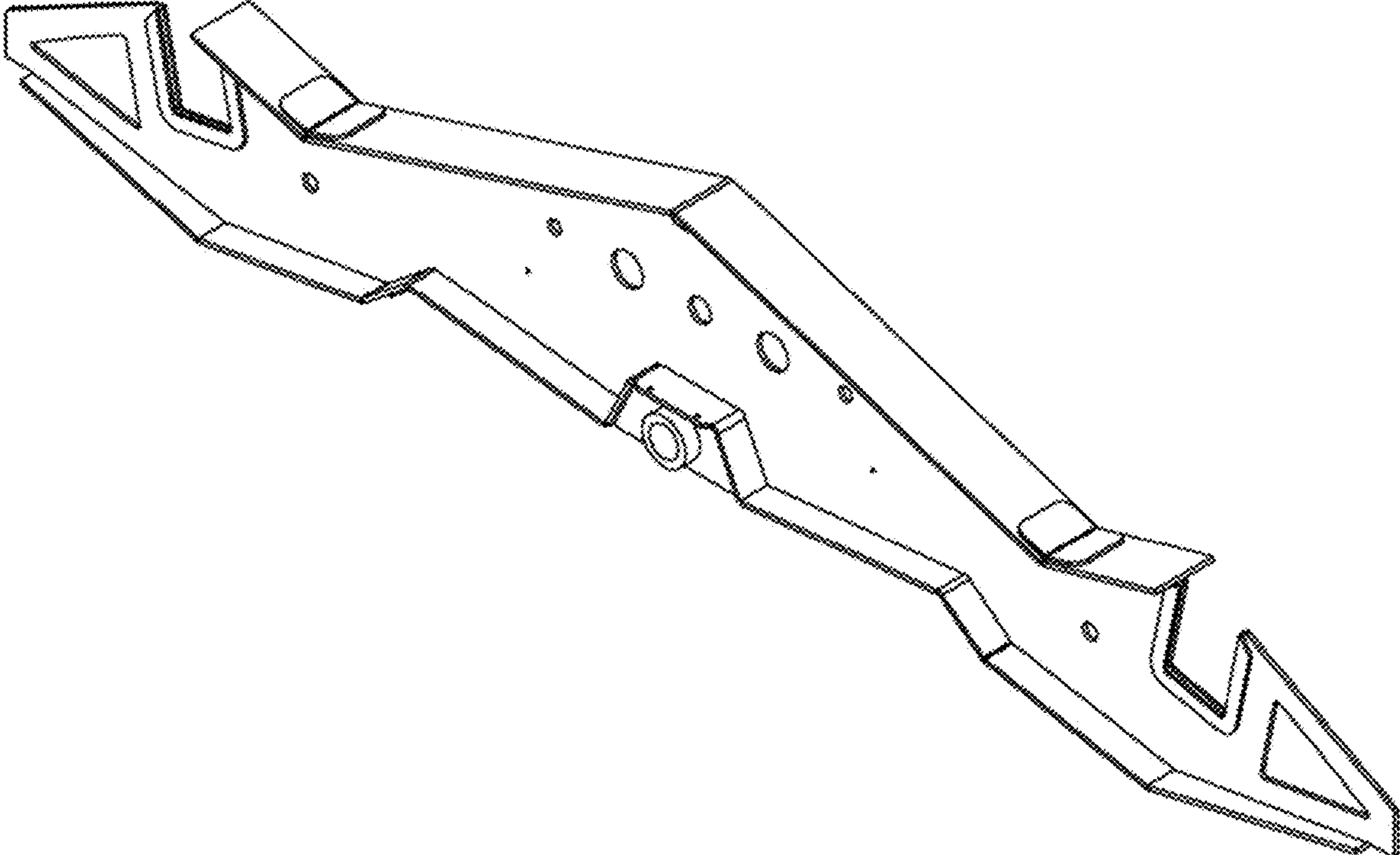

FIG. 1

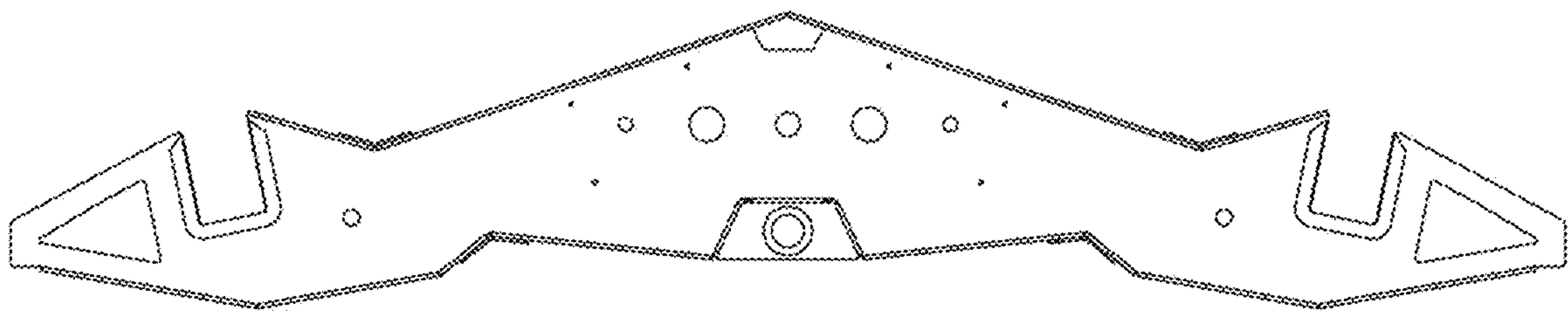

FIG. 2

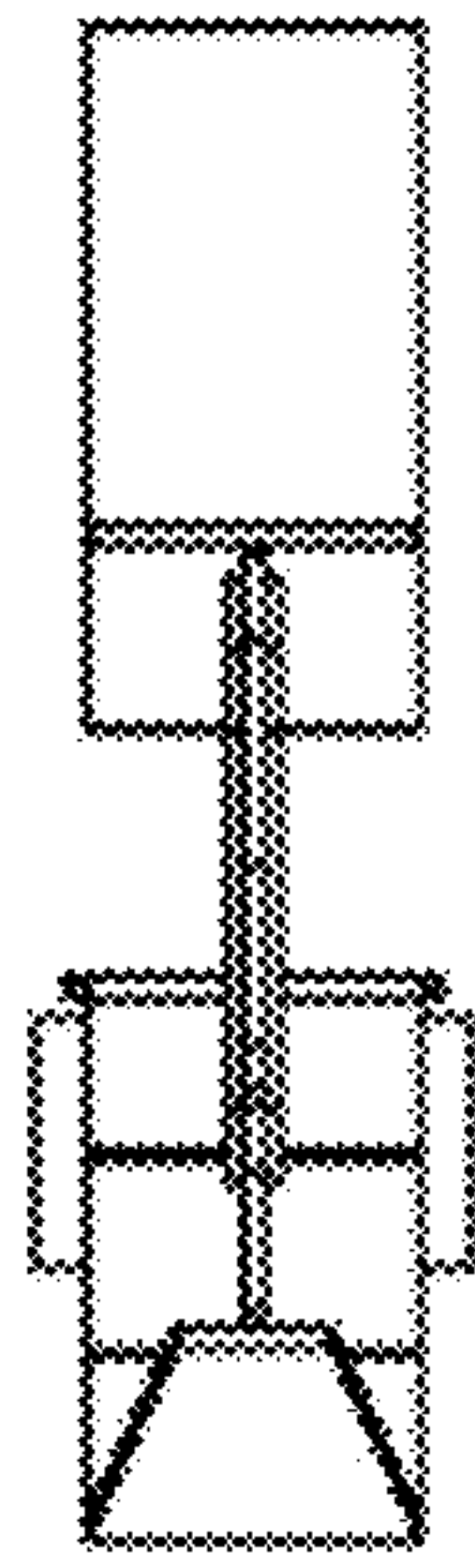

FIG. 3

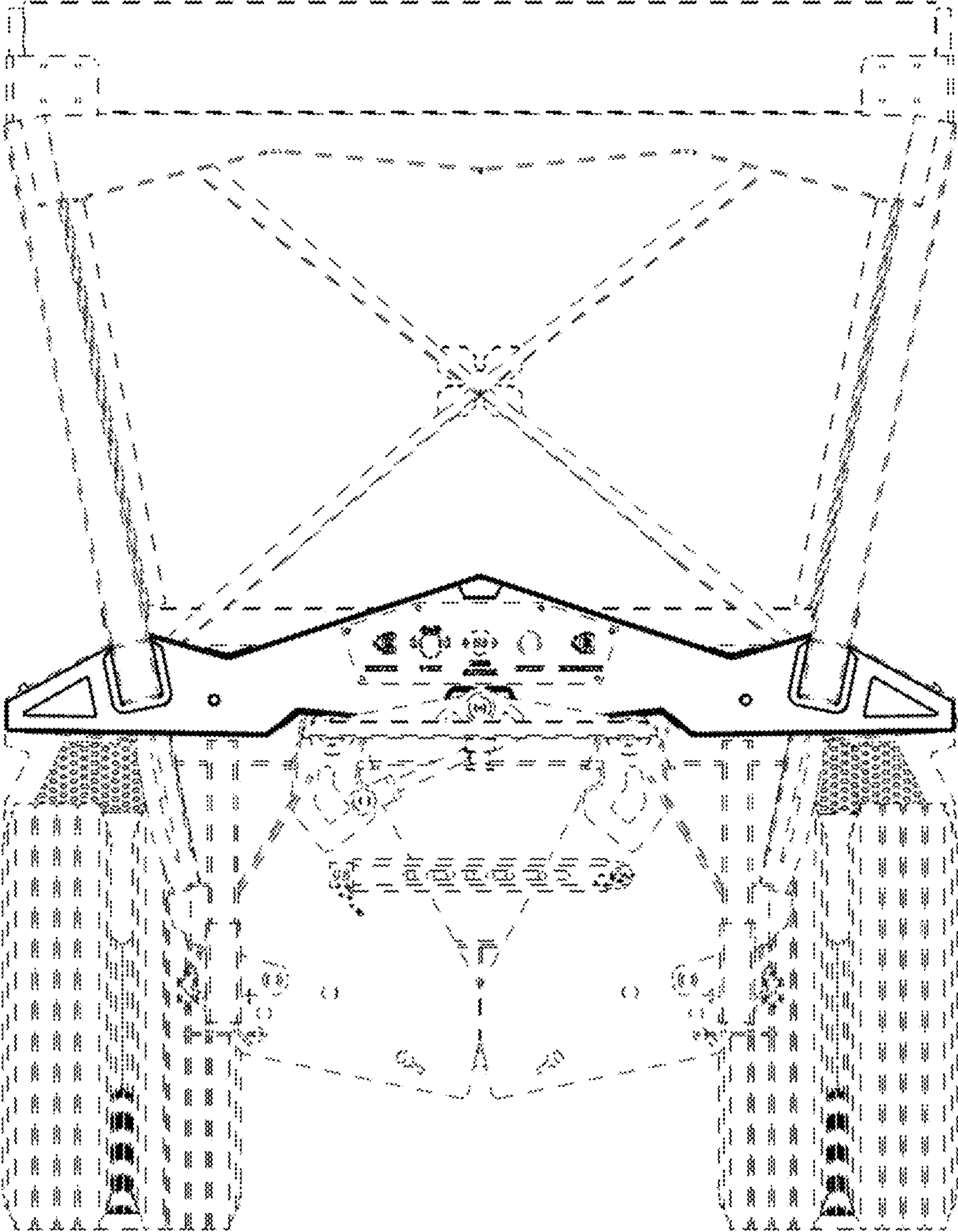

FIG. 4