



US00D920852S

(12) **United States Design Patent**
Ytterborn et al.

(10) **Patent No.:** **US D920,852 S**
(45) **Date of Patent:** **** Jun. 1, 2021**

(54) **ELECTRIC MOTORCYCLE**
(71) Applicant: **Cake 0 emission AB**, Stockholm (SE)
(72) Inventors: **Stefan Ytterborn**, Stockholm (SE);
David Gonzales, Stockholm (SE);
Oskar Milke, Stockholm (SE); **Marcus Carlsson**, Stockholm (SE)

D456,315 S * 4/2002 Sawabe D12/110
D482,639 S * 11/2003 Yamamoto D12/110
D497,329 S * 10/2004 Yamamoto D12/110
D497,330 S * 10/2004 Fukuyama D12/110
D513,481 S * 1/2006 Lin D12/110
D517,956 S * 3/2006 Kishi D12/110
D523,783 S * 6/2006 Sugimoto D12/110
D524,191 S * 7/2006 Sugimoto D12/110
D526,249 S * 8/2006 Tanaka D12/110
D526,936 S * 8/2006 Maruyama D12/110

(Continued)

(73) Assignee: **CAKE 0 EMISSION AB**, Stockholm (SE)

(**) Term: **15 Years**

(21) Appl. No.: **29/711,881**

(22) Filed: **Nov. 4, 2019**

(30) **Foreign Application Priority Data**

May 6, 2019 (EM) 006428256

(51) **LOC (13) Cl.** **12-11**

(52) **U.S. Cl.**
USPC **D12/110**

(58) **Field of Classification Search**
USPC D12/110, 111, 117; D21/432, 532
CPC . B62K 11/00; B62K 11/1102; B62K 11/1104;
B62K 11/111; B62K 11/17; B62K 11/19;
B62K 11/2202

See application file for complete search history.

(56) **References Cited**

U.S. PATENT DOCUMENTS

D291,292 S * 8/1987 Smith D12/111
D311,507 S * 10/1990 Sasaki D12/110
D368,242 S * 3/1996 Camfield D12/111
D384,600 S * 10/1997 Miwa D12/110
D385,226 S * 10/1997 Mogi D12/110
D387,017 S * 12/1997 Wakita D12/110
D430,822 S * 9/2000 Sakaguchi D12/110
D431,501 S * 10/2000 Yamamoto D12/110

OTHER PUBLICATIONS

“Truvor is a new electric scrambler” Pablo Baranoff Dorn., posted date Dec. 30, 2019 [online], [retrieved on Dec. 16, 2020]. Retrieved from the Internet: <URL: <https://electricmotorcycles.news/truvor-is-a-new-electric-scrambler-designed-by-pablo-baranoff-dorn-and-denzel-electric-bike/>> (Year: 2019).*

(Continued)

Primary Examiner — Darlington Ly

Assistant Examiner — Nasim Abdulaziz Ali

(74) *Attorney, Agent, or Firm* — Tucker Ellis LLP

(57) **CLAIM**

The ornamental design for an electric motorcycle, as shown and described.

DESCRIPTION

FIG. 1 is a front and right side perspective view of an electric motorcycle embodying our new design; FIG. 2 is a left side elevation view thereof; FIG. 3 is a right side elevation view thereof; FIG. 4 is a front elevation view thereof; FIG. 5 is a rear elevation view thereof; FIG. 6 is a top plan view thereof; and, FIG. 7 is a bottom plan view thereof.

The broken lines in the drawings illustrate portions of the electric motorcycle that form no part of the claimed design.

1 Claim, 4 Drawing Sheets

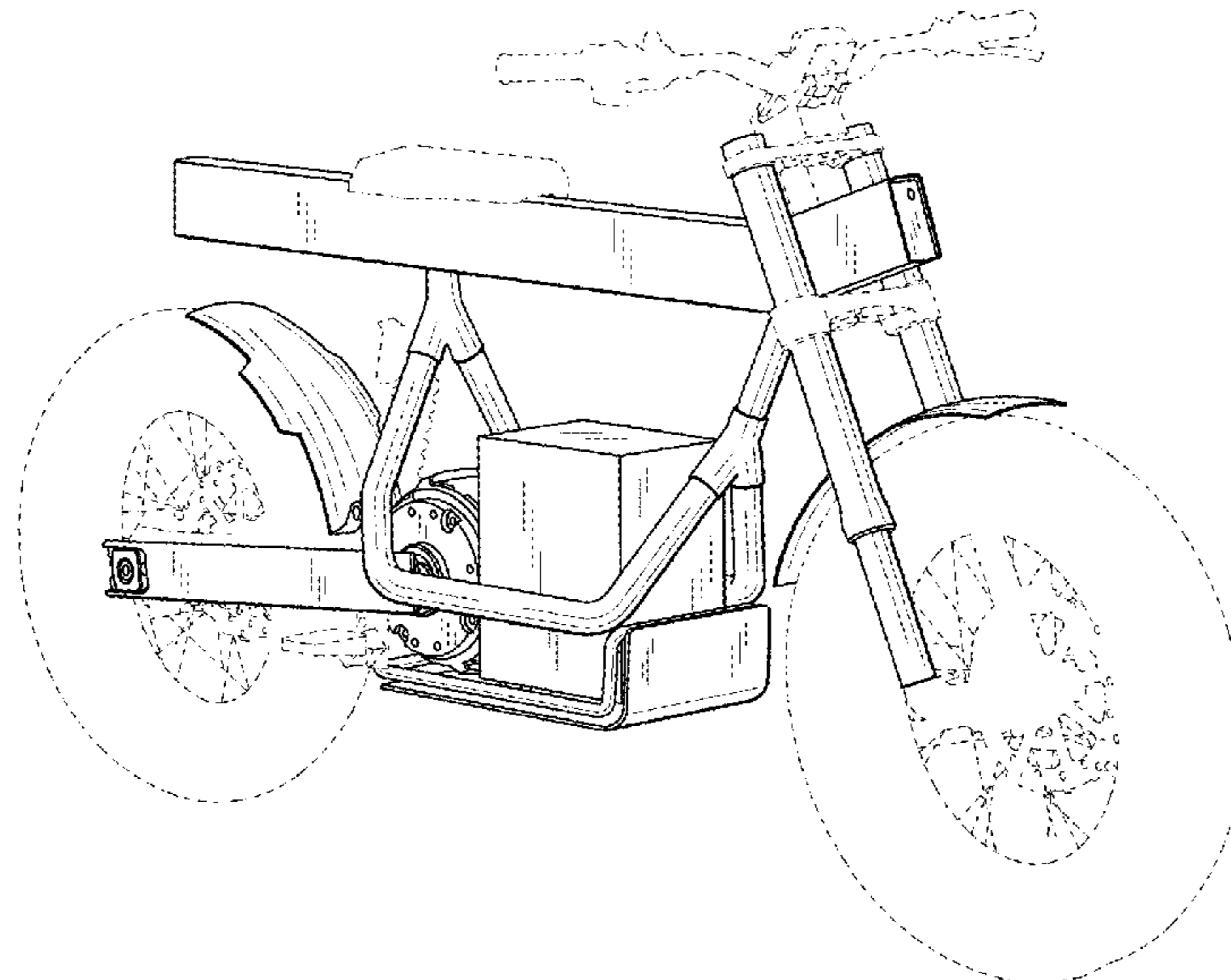

(56)

References Cited

U.S. PATENT DOCUMENTS

D549,136 S * 8/2007 Yu D12/110
 D559,155 S * 1/2008 Sakata D12/110
 D566,626 S * 4/2008 Sakata D12/110
 D578,042 S * 10/2008 Yang D12/111
 D581,840 S * 12/2008 Ichihara D12/110
 D587,630 S * 3/2009 Yang D12/111
 D590,302 S * 4/2009 Tanaka D12/110
 D594,784 S * 6/2009 Ichihara D12/110
 D598,330 S * 8/2009 Miyanishi D12/110
 D603,300 S * 11/2009 Fukuyama D12/110
 D609,609 S * 2/2010 Hayashi D12/110
 D609,610 S * 2/2010 Inose D12/110
 D620,400 S * 7/2010 Haller D12/111
 D620,401 S * 7/2010 Haller D12/111
 D621,301 S * 8/2010 Hayashi D12/110
 D632,226 S * 2/2011 Miyata D12/110
 D640,173 S * 6/2011 Oyanagi D12/110
 D645,791 S * 9/2011 Lee D12/110
 D653,590 S * 2/2012 Patterson D12/110
 D662,857 S * 7/2012 Petersson D12/110
 D662,858 S * 7/2012 Yamazaki D12/110
 D662,859 S * 7/2012 Matsuoka D12/110
 D665,706 S * 8/2012 Oyanagi D12/110
 D685,682 S * 7/2013 Matsumura D12/110
 D686,540 S * 7/2013 Hinderhofer D12/111
 D689,798 S * 9/2013 Patterson D12/111
 D694,672 S * 12/2013 Starck D12/110
 D698,702 S * 2/2014 Kubanek D12/110
 D724,496 S * 3/2015 Takeda D12/110
 D734,215 S * 7/2015 Forrellad D12/110
 D735,086 S * 7/2015 Talios D12/110
 D735,087 S * 7/2015 Iimura D12/110
 D738,260 S * 9/2015 Akita D12/110

D738,789 S * 9/2015 Inose D12/110
 D754,567 S * 4/2016 Iimura D12/110
 D774,977 S * 12/2016 Greiner D12/111
 D776,577 S * 1/2017 Greiner D12/111
 D797,609 S * 9/2017 Gonzalez-Gancedo Carrillo-
 Albornoz D12/111
 D798,195 S * 9/2017 Yu D12/110
 D803,103 S * 11/2017 Clyde D12/110
 D810,629 S * 2/2018 Ytterborn D12/110
 D814,359 S * 4/2018 Nishimoto D12/110
 D814,978 S * 4/2018 Niu D12/110
 D815,990 S * 4/2018 Jane Santamaria D12/110
 D815,991 S * 4/2018 Clyde D12/110
 D820,732 S * 6/2018 Francis D12/110
 D833,916 S * 11/2018 Yu D12/111
 D868,636 S * 12/2019 Ytterborn D12/110
 D885,983 S * 6/2020 Ytterborn D12/110
 D901,336 S * 11/2020 Kuehne D12/111
 D903,532 S * 12/2020 Ma D12/111
 2005/0029773 A1 * 2/2005 Day B62K 25/04
 280/284

OTHER PUBLICATIONS

“Harley-Davidson’s latest electric bikes are designed for commuters” Harley-Davidson’s., posted date Feb. 13, 2019 [online], [retrieved on Dec. 16, 2020]. Retrieved from the Internet: <URL: <https://www.dezeen.com/2019/02/13/harley-davidson-electric-commute-bikes-design/>> (Year: 2019).*

“NOVUS electric motorcycle” NOVUS., posted date Jan. 4, 2019 [online], [retrieved on Dec. 16, 2020]. Retrieved from the Internet: <URL: <https://electricmotorcycles.news/novus-presents-their-new-novus-electric-motorcycle-at-ces-2019-in-las-vegas/>> (Year: 2019).*

* cited by examiner

FIG. 1

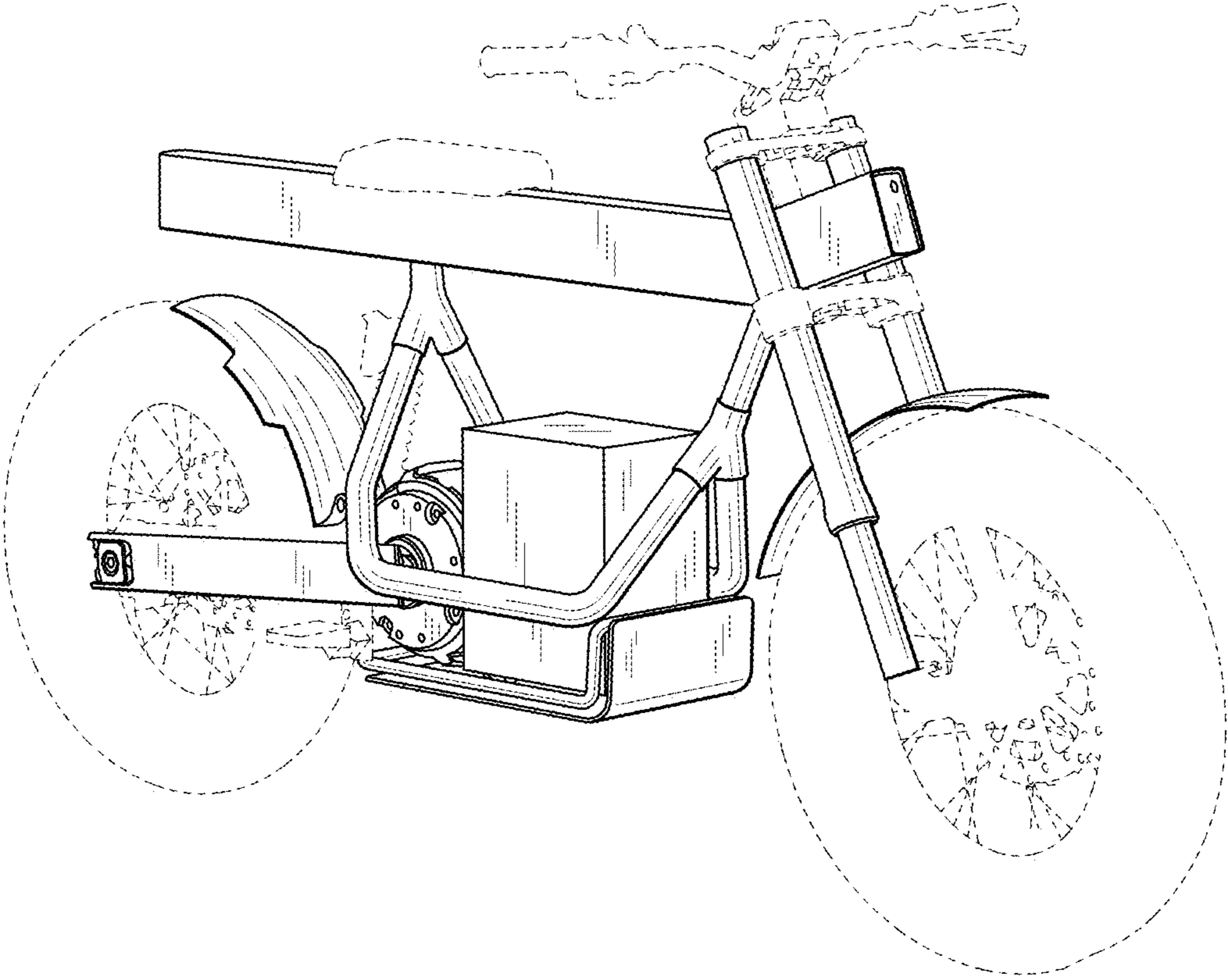

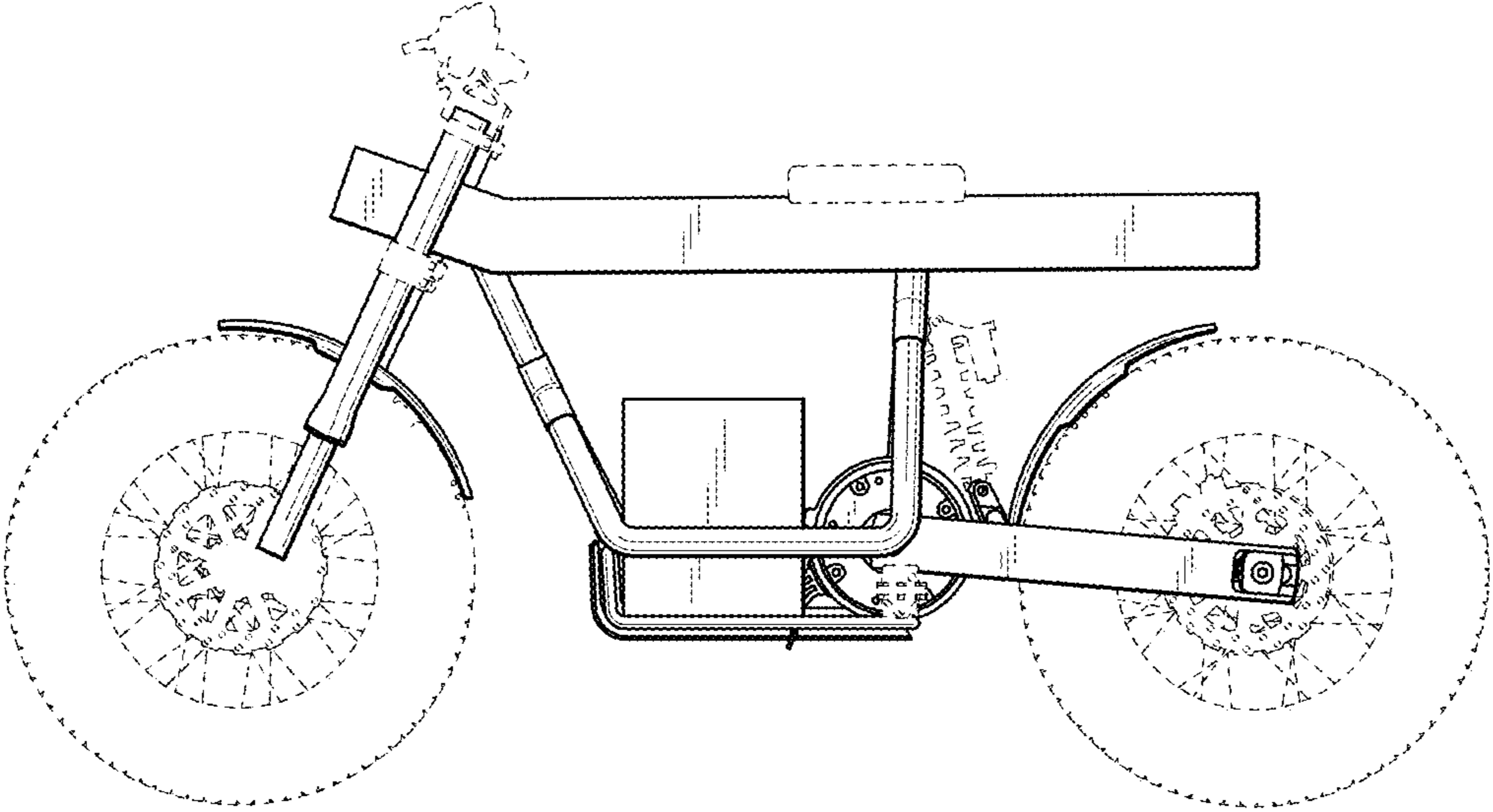

FIG. 2

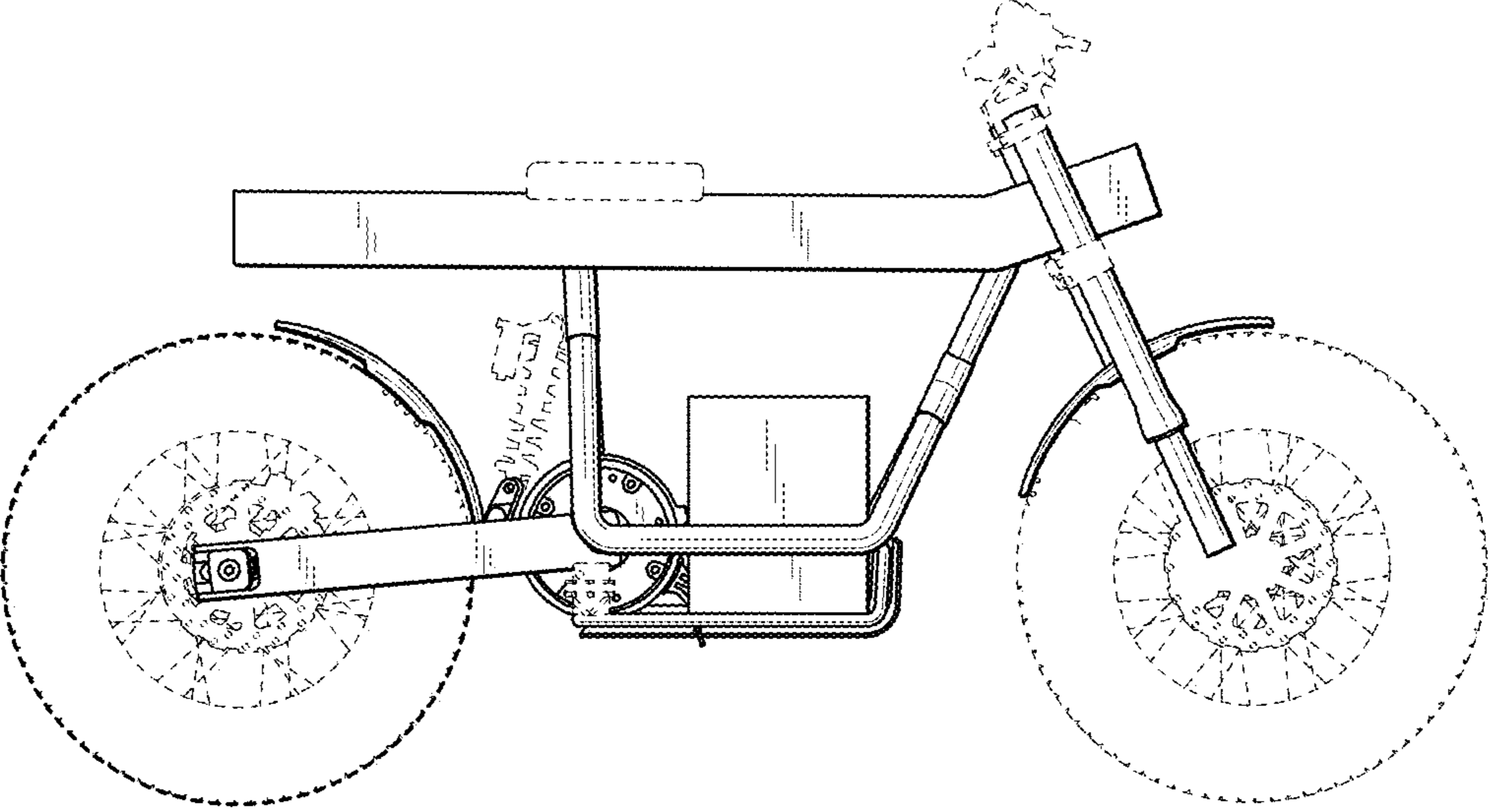

FIG. 3

FIG. 4

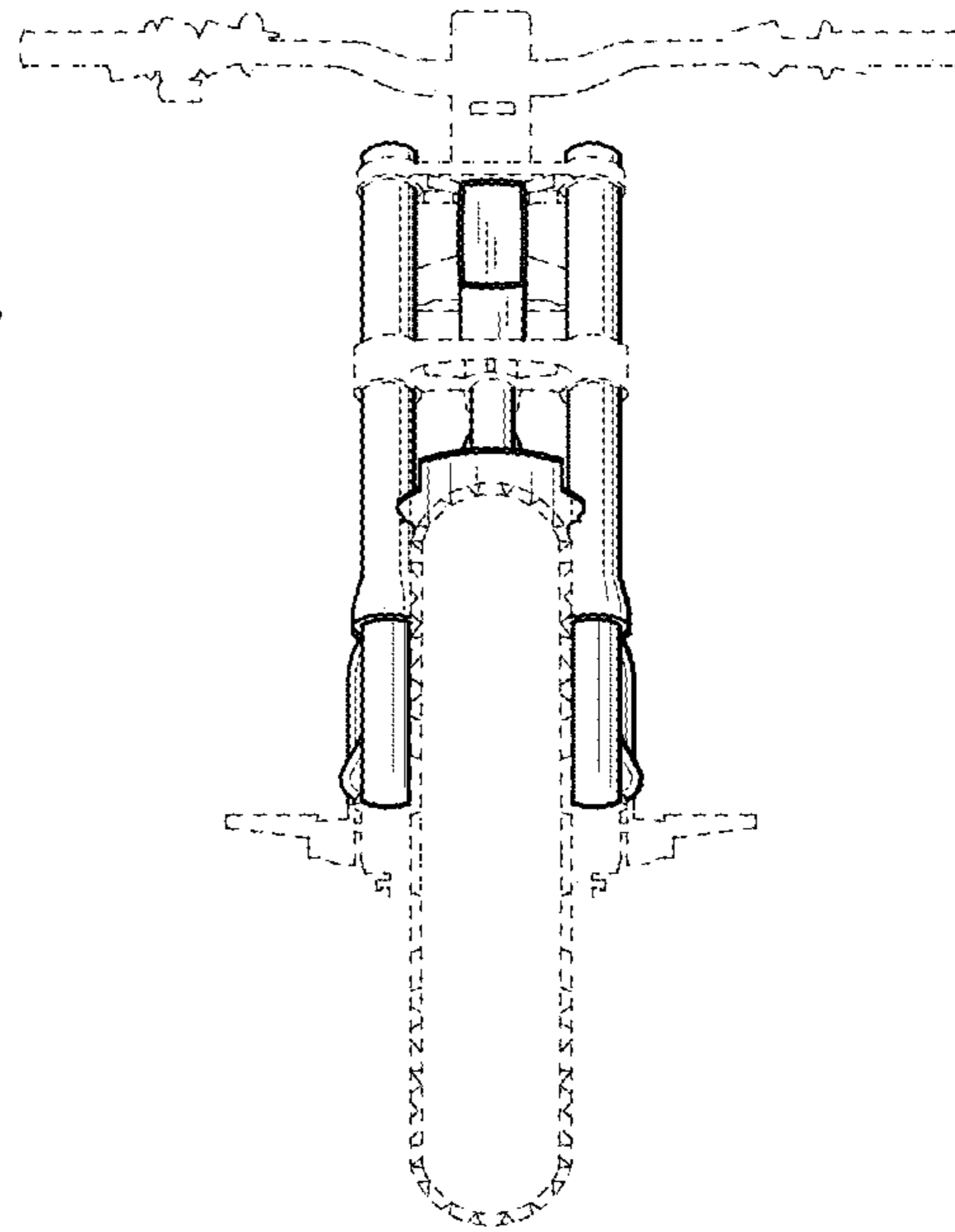

FIG. 5

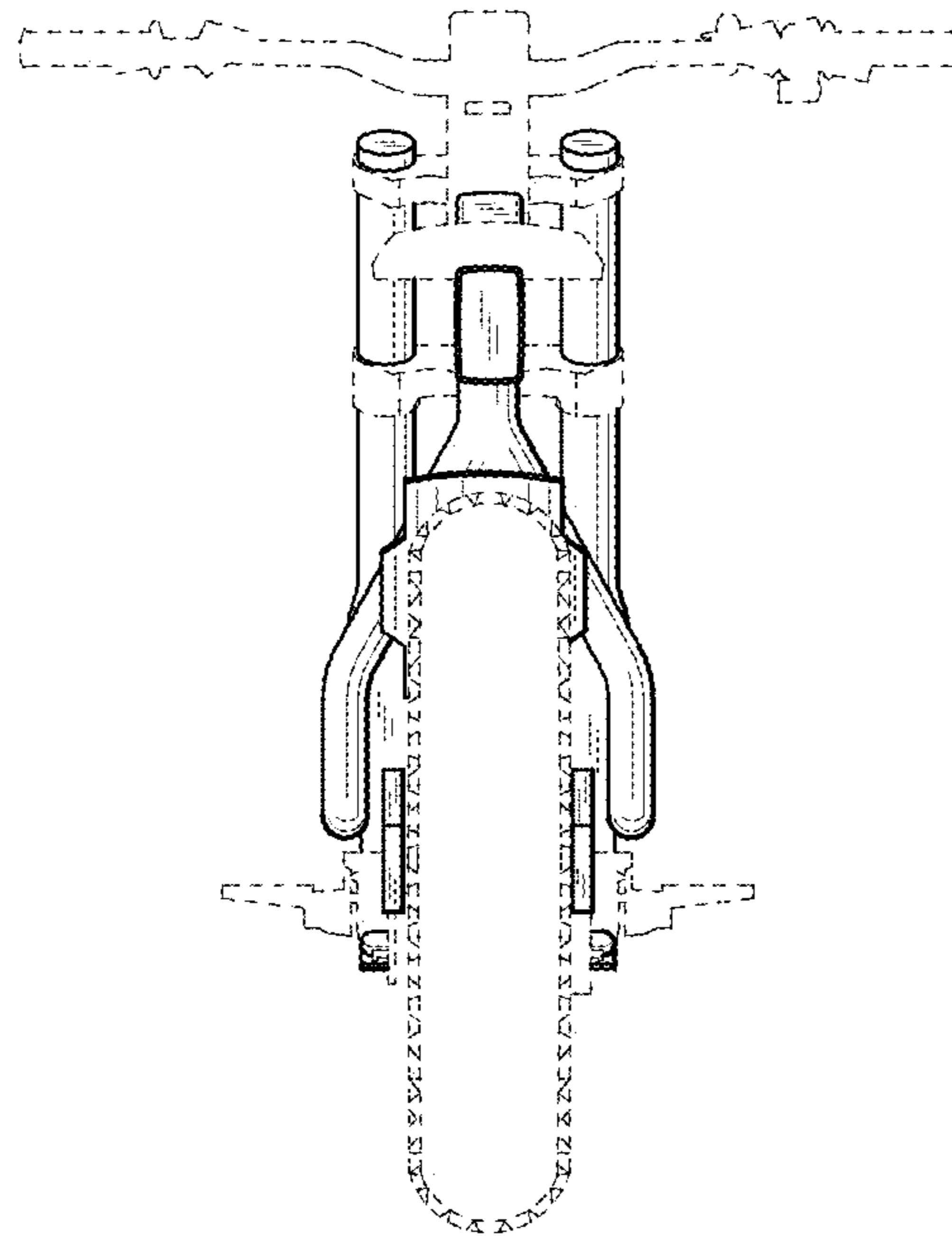

FIG. 6

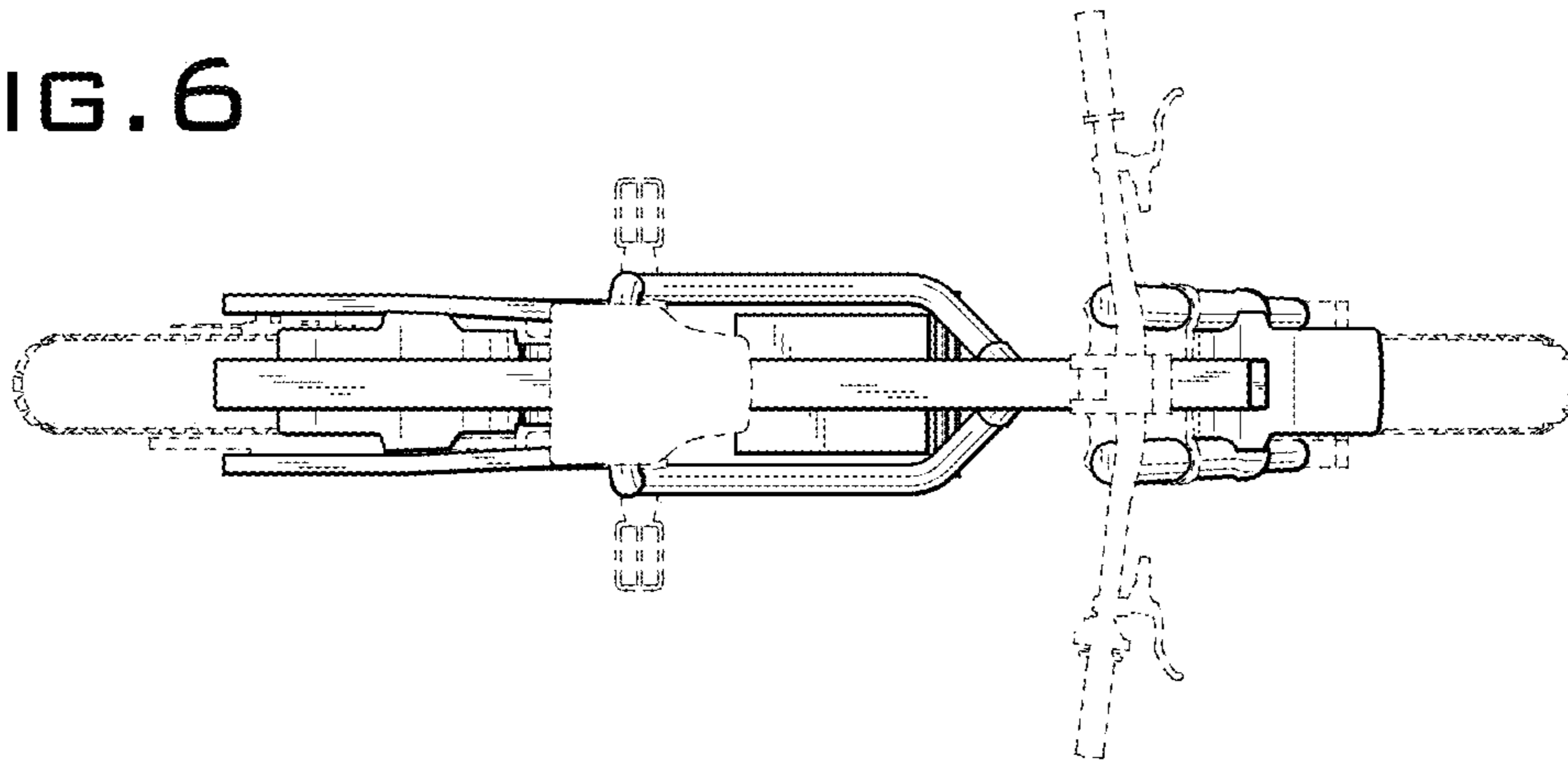

FIG. 7

