



US00D920848S

(12) **United States Design Patent**
Kuehne et al.

(10) **Patent No.:** **US D920,848 S**
(45) **Date of Patent:** **** Jun. 1, 2021**

(54) **ELECTRIC MOTORCYCLE**
(71) Applicant: **Harley-Davidson Motor Company Group, LLC, Milwaukee, WI (US)**
(72) Inventors: **Tyler Kuehne, Milwaukee, WI (US); Michael Decaluwe, Jackson, WI (US); Casey Ketterhagen, Hartland, WI (US); Samuel N. Reiting, Wauwatosa, WI (US); Eric J. Konkel, Hartland, WI (US); Anthony N. Pink, Hartford, WI (US); Ben McGinley, Glendale, WI (US)**

D200,286 S 2/1965 Ryan
3,212,791 A * 10/1965 Edwins B62K 11/06
280/275
D203,146 S 12/1965 Ryan
D203,492 S 1/1966 Nault
3,301,575 A * 1/1967 Ryan B62K 3/00
280/275
D216,538 S 2/1970 Hill
3,875,696 A 4/1975 Howland
4,022,484 A * 5/1977 Davis B62K 11/02
280/284
D267,472 S 1/1983 Kanemitsu
4,396,085 A 8/1983 Inoue et al.
(Continued)

(73) Assignee: **Harley-Davidson Motor Company Group, LLC, Milwaukee, WI (US)**

(**) Term: **15 Years**

(21) Appl. No.: **29/691,268**

(22) Filed: **May 15, 2019**

(51) **LOC (13) Cl.** **12-11**

(52) **U.S. Cl.**
USPC **D12/110**

(58) **Field of Classification Search**
USPC D12/110, 111, 117; D21/432, 538
CPC B62K 11/00; B62K 11/02; B62K 11/04;
B62K 11/10; B62K 17/00; B62K 19/00;
B62K 2202/00

See application file for complete search history.

(56) **References Cited**

U.S. PATENT DOCUMENTS

2,445,058 A * 7/1948 Fields B62M 25/00
180/335
2,863,672 A * 12/1958 Yorimasa B62K 25/26
280/283
D195,019 S 4/1963 Schreckengost
3,101,822 A * 8/1963 Clemens B62M 7/00
477/209

OTHER PUBLICATIONS

Andrew Cherney. "Harley-Davidson's 2 Electric Concept Bikes Are Ready And Riding." Cycle World., Feb. 8, 2019 [online], [retrieved on Jan. 31, 2021], Retrieved from the Internet <URL: <https://www.cycleworld.com/harley-davidsons-2-electric-concept-bikes-are-ready-and-riding/>>.*

(Continued)

Primary Examiner — Darlington Ly

(74) *Attorney, Agent, or Firm* — Michael Best & Friedrich LLP

(57) **CLAIM**

We claim the ornamental design for an electric motorcycle, as shown and described.

DESCRIPTION

FIG. 1 is a top, front, and left side perspective view of an electric motorcycle embodying our new design; FIG. 2 is a top, front, and right side perspective view thereof; FIG. 3 is a left side elevation view thereof; FIG. 4 is a right side elevation view thereof; FIG. 5 is a front elevation view thereof; FIG. 6 is a rear elevation view thereof; and, FIG. 7 is a top plan view thereof.

1 Claim, 7 Drawing Sheets

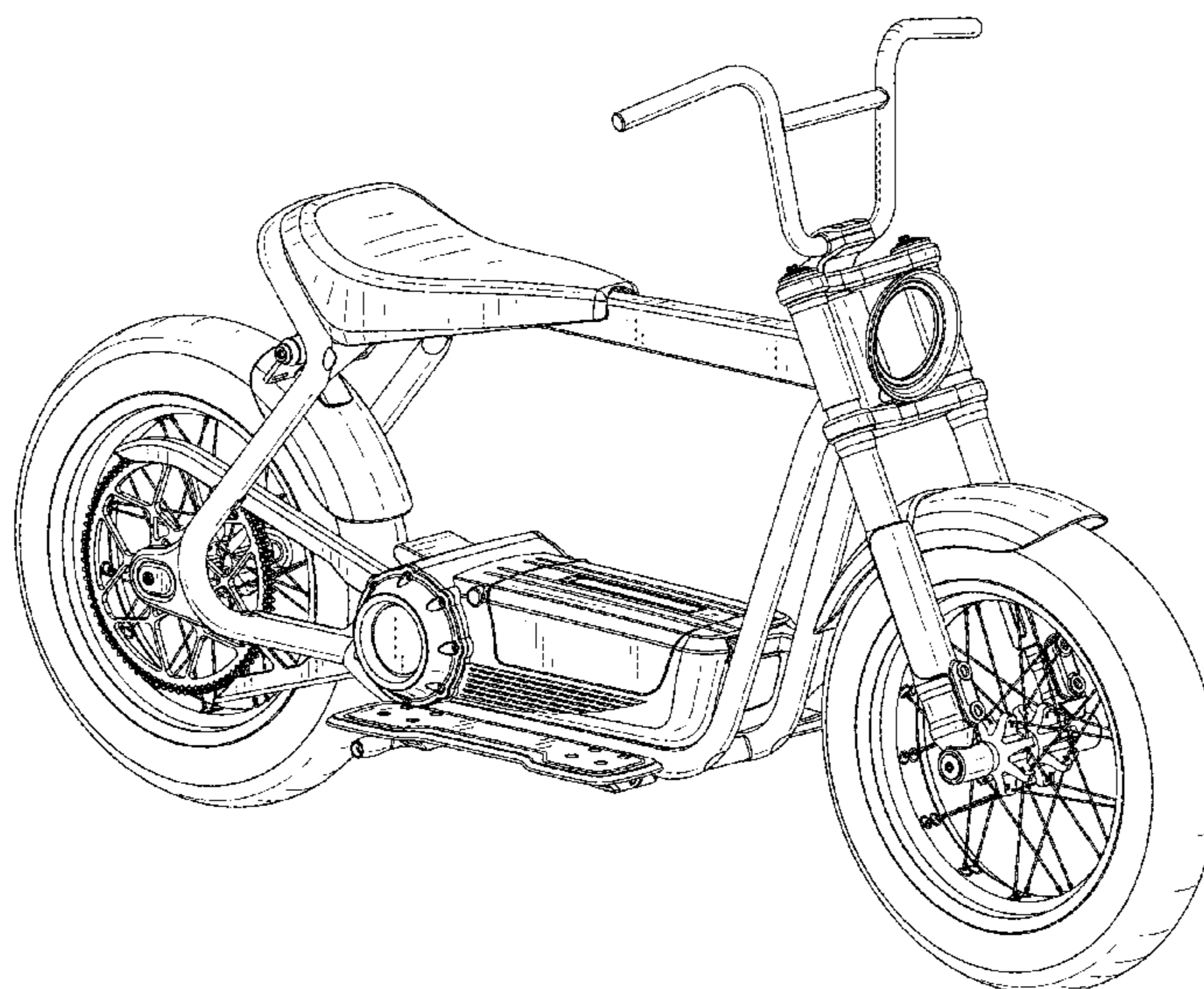

(56)

References Cited

U.S. PATENT DOCUMENTS

D279,376 S 6/1985 Davidson
D319,040 S 8/1991 Evans
D348,036 S 6/1994 Rossigno et al.
D348,676 S 7/1994 Fuller et al.
5,390,758 A * 2/1995 Hunter B60K 5/1208
180/227
D364,129 S 11/1995 Davidson et al.
5,480,001 A * 1/1996 Hara B62K 11/04
180/219
D367,021 S 2/1996 Camfield et al.
D376,567 S 12/1996 Davidson et al.
D386,451 S 11/1997 Liao
D411,489 S 6/1999 Davidson et al.
D411,817 S 7/1999 Davidson et al.
D420,310 S * 2/2000 Spriggs D12/111
D424,480 S 5/2000 Ricci
D428,832 S 8/2000 Matthies
D432,952 S * 10/2000 Scruggs D12/110
D446,476 S * 8/2001 Wallace D12/110
D453,489 S * 2/2002 Wallace D12/110
6,464,031 B1 * 10/2002 Cobb B62K 11/04
180/205.4
D469,213 S 1/2003 Huang
D480,335 S * 10/2003 James D12/110
D480,664 S * 10/2003 James D12/110
D480,993 S * 10/2003 James D12/110
D483,698 S * 12/2003 Basura D12/111
D485,789 S * 1/2004 Lai D12/111
D487,523 S 3/2004 Hammer
D498,012 S 11/2004 Ballentine
D506,845 S 6/2005 Nernimont
D507,838 S 7/2005 Nernimont
D509,188 S 9/2005 Mayer et al.
D517,229 S 3/2006 Nernimont
D523,168 S 6/2006 Reed et al.
D533,811 S 12/2006 Hoisington et al.
D554,245 S 10/2007 Geyer, III
D556,101 S 11/2007 Huributt
D564,420 S 3/2008 Devlin
D570,272 S 6/2008 Jones et al.
D591,203 S * 4/2009 Martin D12/110
D619,945 S 7/2010 Sadanowicz et al.
D622,638 S 8/2010 Uimonen
D632,615 S 2/2011 Uimonen
D645,791 S * 9/2011 Lee D12/110
D653,590 S * 2/2012 Patterson D12/110
D662,445 S 6/2012 Uimonen
D666,536 S 9/2012 Uimonen
D666,946 S 9/2012 Uimonen
D688,608 S 8/2013 Amy
D689,798 S * 9/2013 Patterson D12/111
D693,739 S 11/2013 Uimonen
D721,014 S 1/2015 Kahler, Jr.
D723,983 S 3/2015 Blanca
D724,255 S 3/2015 Lerbin et al.

9,371,105 B2 6/2016 Chou
9,604,690 B2 3/2017 Huber et al.
D783,463 S 4/2017 Reed
D802,487 S 11/2017 Petrov
D803,728 S 11/2017 Kamler et al.
9,908,582 B1 3/2018 Choi et al.
9,963,187 B1 5/2018 Quan et al.
D820,199 S 6/2018 Francis
D824,290 S * 7/2018 Sukkar D12/110
D826,101 S 8/2018 Uimonen et al.
D830,911 S * 10/2018 Li D12/110
D838,230 S 1/2019 Ghannam et al.
D838,231 S 1/2019 Ghannam et al.
D840,876 S 2/2019 De Roeck
D852,680 S 7/2019 Ness et al.
D852,847 S 7/2019 Christoph et al.
D853,889 S * 7/2019 Pits D12/110
D864,794 S * 10/2019 Waters D12/110
D864,795 S * 10/2019 Waters D12/110
10,488,231 B2 11/2019 Ghannam et al.
D876,991 S 3/2020 Tsai et al.
D878,973 S 3/2020 McGinley et al.
D885,985 S 6/2020 Tan
D901,336 S * 11/2020 Kuehne D12/111
2005/0092560 A1 5/2005 Brotherton et al.
2007/0289826 A1 12/2007 Suryatama et al.
2008/0073139 A1 * 3/2008 Conrad B62K 25/283
180/227
2014/0084623 A1 3/2014 Vliyamoto et al.
2015/0167765 A1 6/2015 Lantan

OTHER PUBLICATIONS

“#LiveWire and other #Harley Davidson lightweight #electric concepts . . . ” Twitter., Apr. 8, 2019 [online], [retrieved on Jan. 31, 2021], Retrieved from the Internet <URL: <https://twitter.com/harleydavidson/status/1115358699210584065/photo/3>>.*
Jonathon Ramsey. “Harley-Davidson shows off ideas for future electric motorcycles.” Autoblog., Jan. 29, 2020 [online], [retrieved on Jan. 31, 2021], Retrieved from the Internet <URL: <https://www.autoblog.com/2020/01/28/harley-davidson-electric-motorcycle-scooter/>>.*
Harley Davidson, “CES 2019:Harley-Davidson New Concepts and Livewire Motorcycle”, Webpage: <https://www.totalmotorcycle.com/ces-2019-harley-davidson-electrifies-the-future-with-new-concepts-and-livewire-motorcycle/>, May 9, 2019.
Harley Davidson, “Electric Motorcycles Harley Davidson USA”, Webpage: <https://www.harley-davidson.com/us/en/motorcycles/future-vehicles/electric.html>, May 9, 2019.
Societa Piemontese Automobili, “Spa Bicietto Electric Bike Looks Amazing, but the Price Is Painful”, Webpage: <https://www.autoevolution.com/news/spa-bicicletto-electric-bike-looks-amazing-but-the-price-is-painful-video-photo-gallery-93695.html>, Mar. 25, 2015.

* cited by examiner

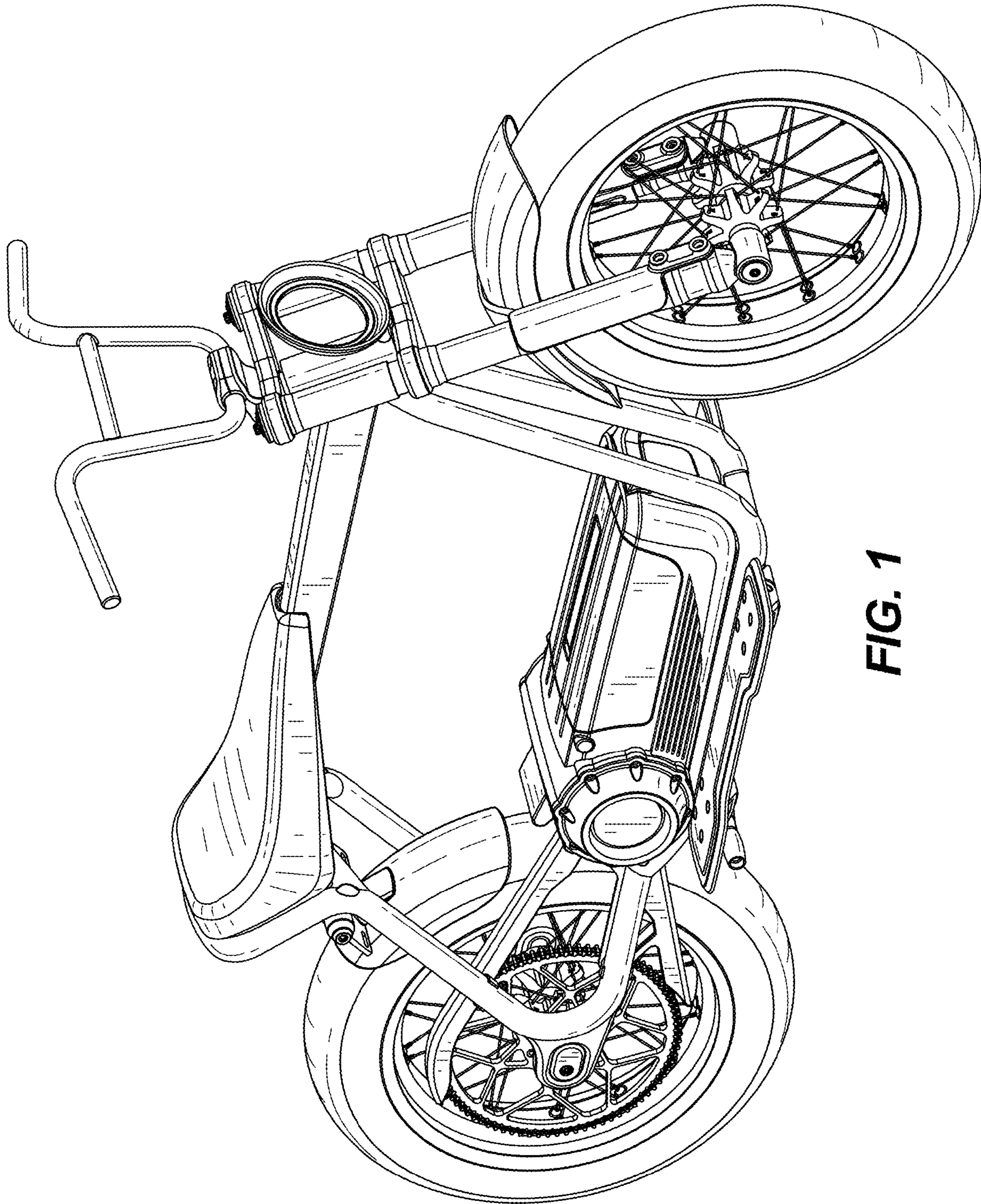

FIG. 1

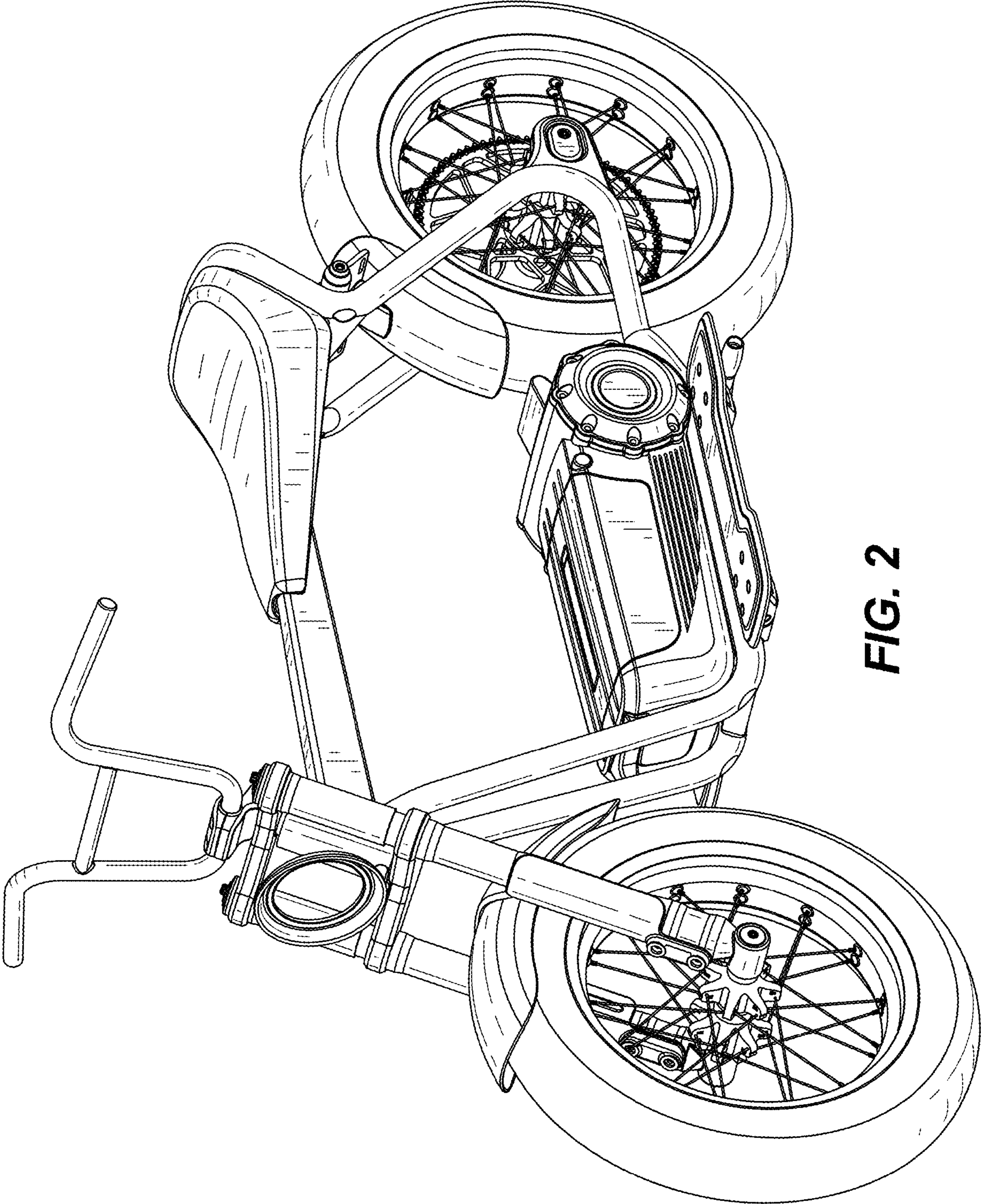

FIG. 2

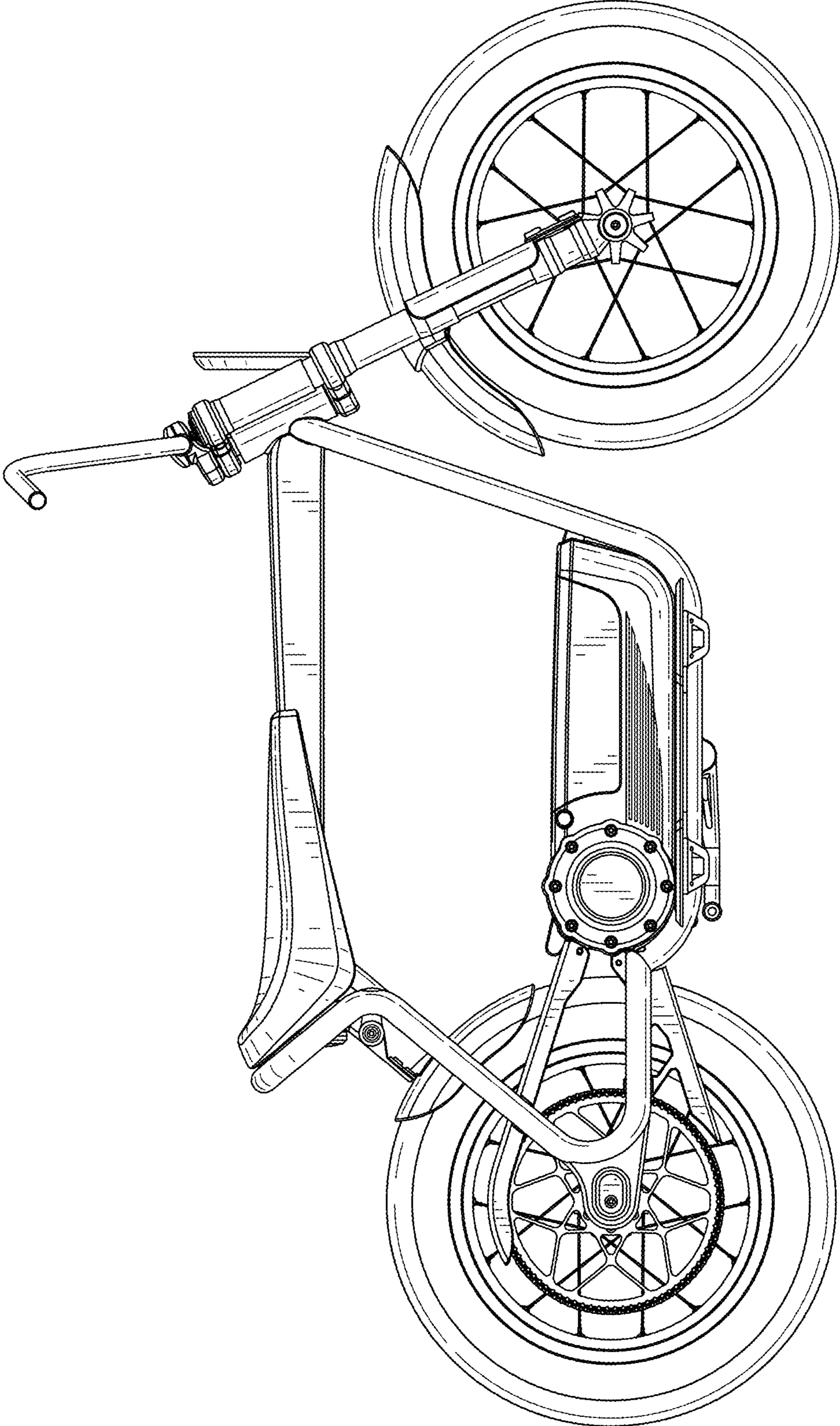

FIG. 3

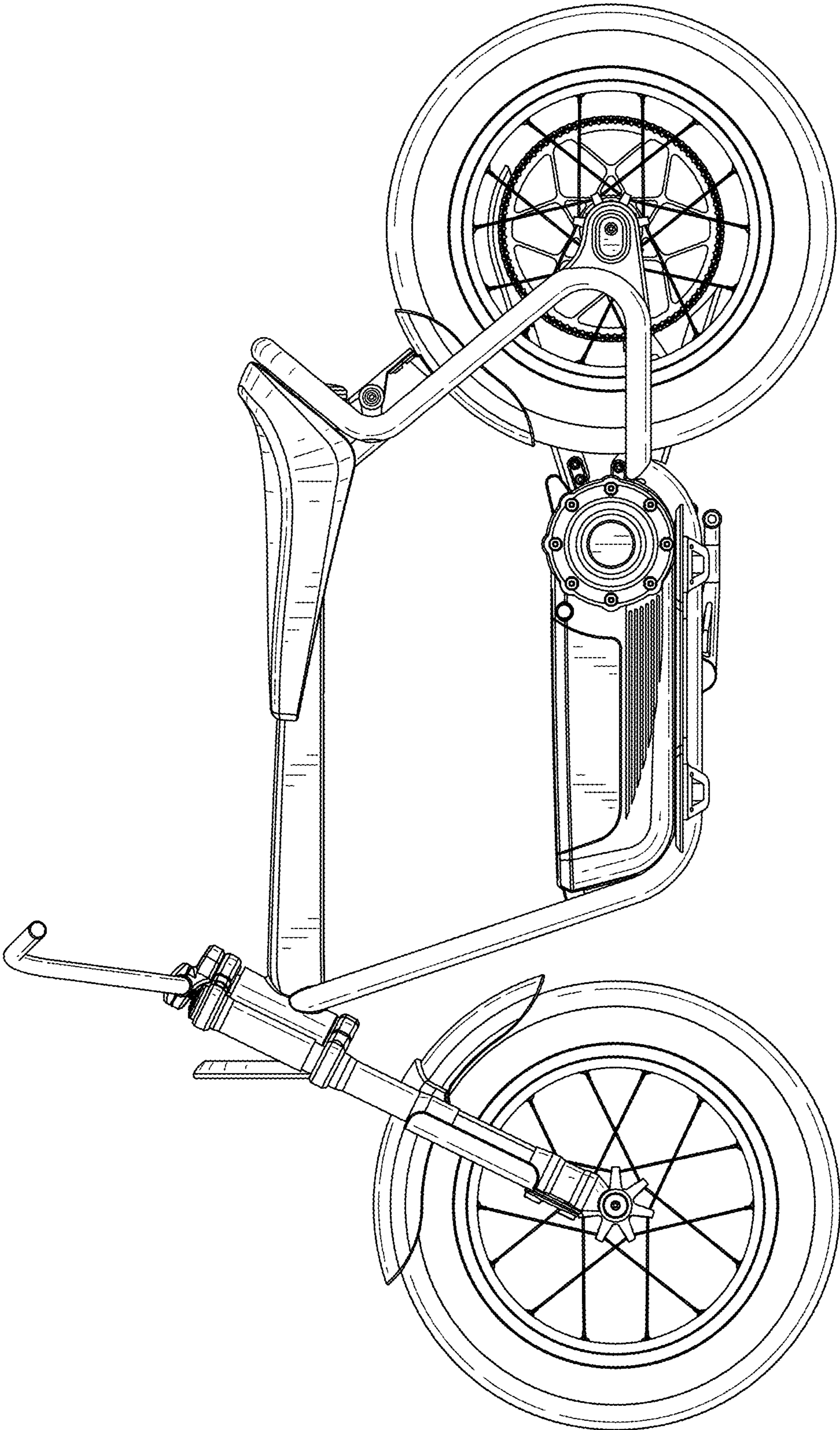

FIG. 4

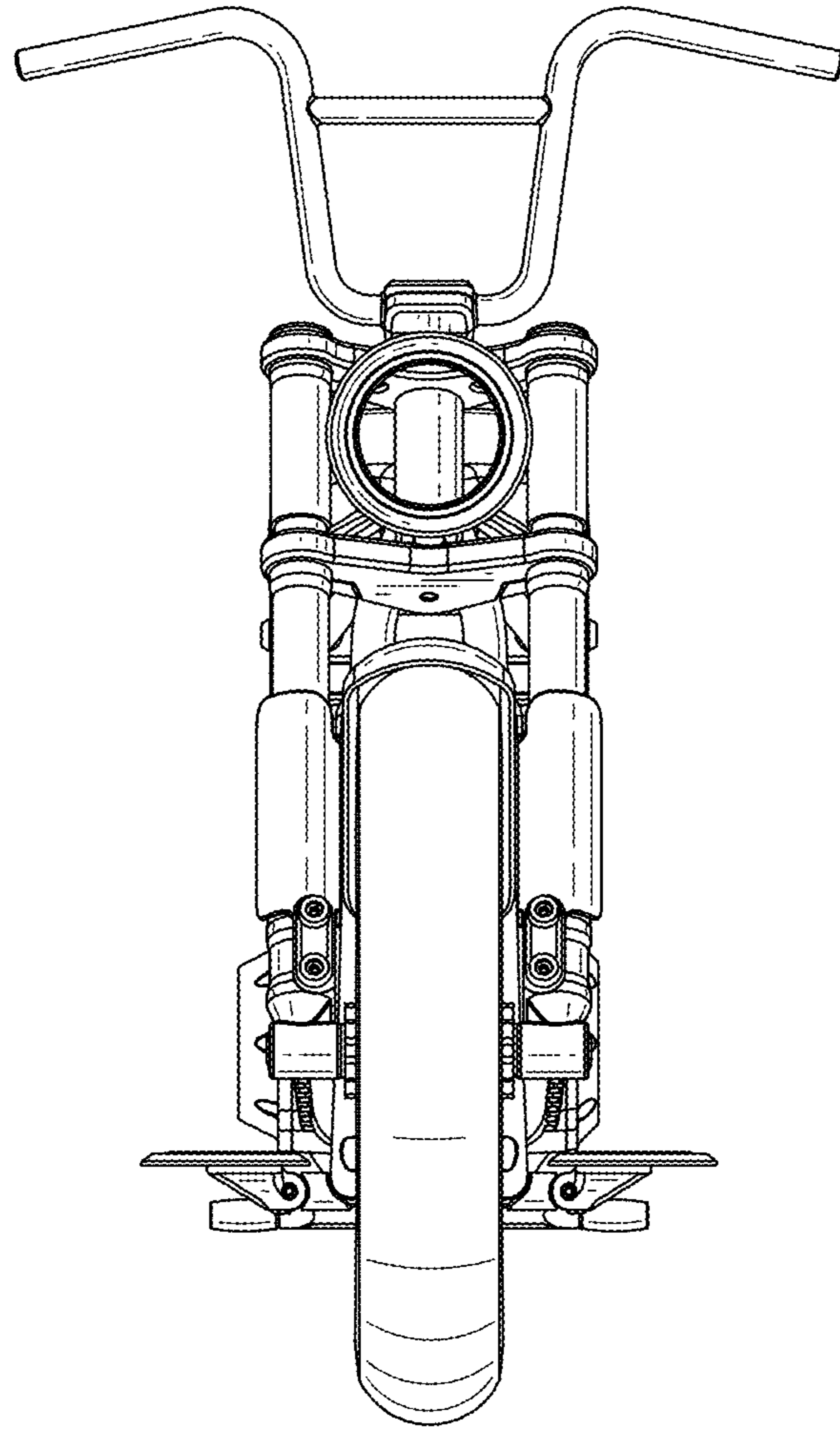

FIG. 5

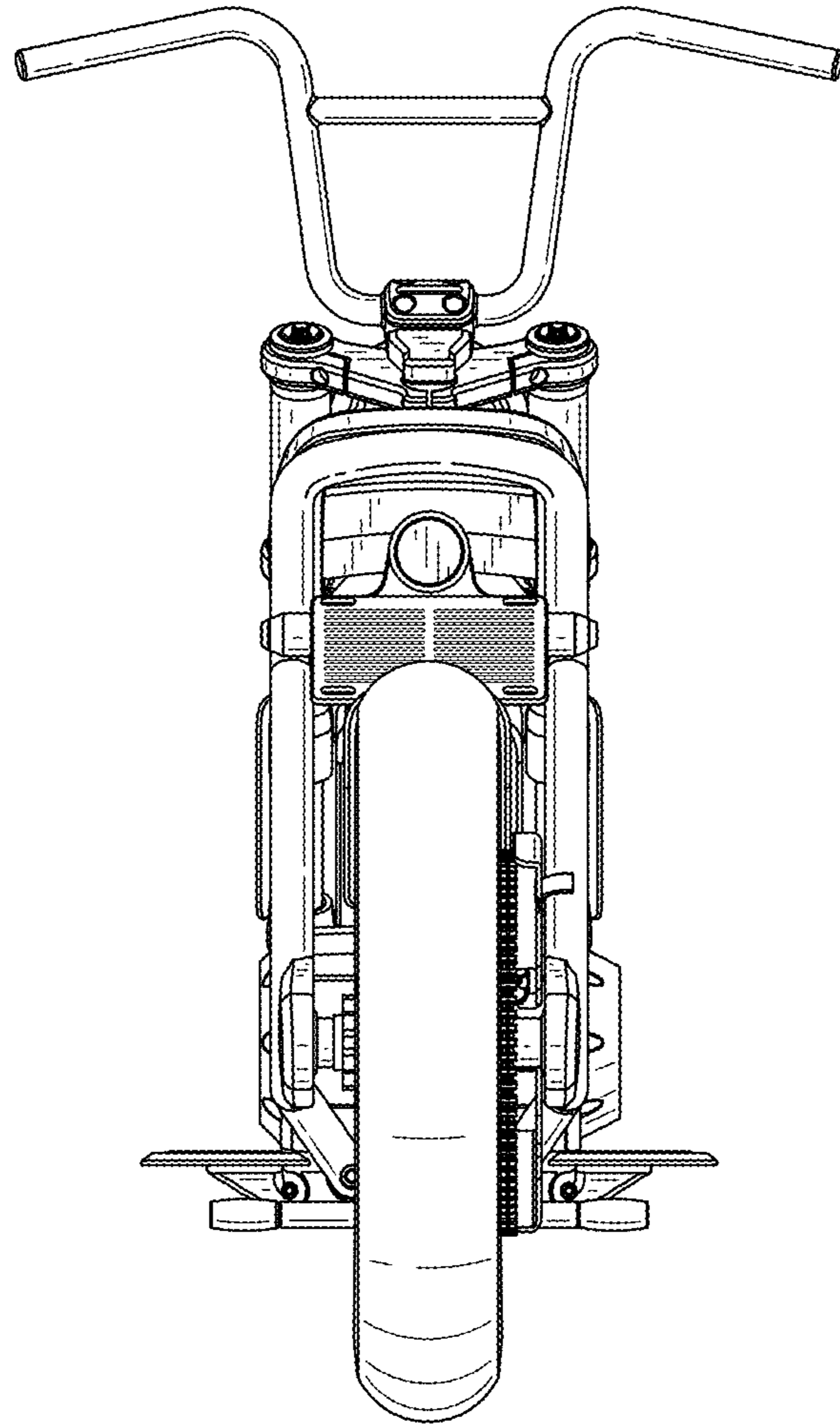

FIG. 6

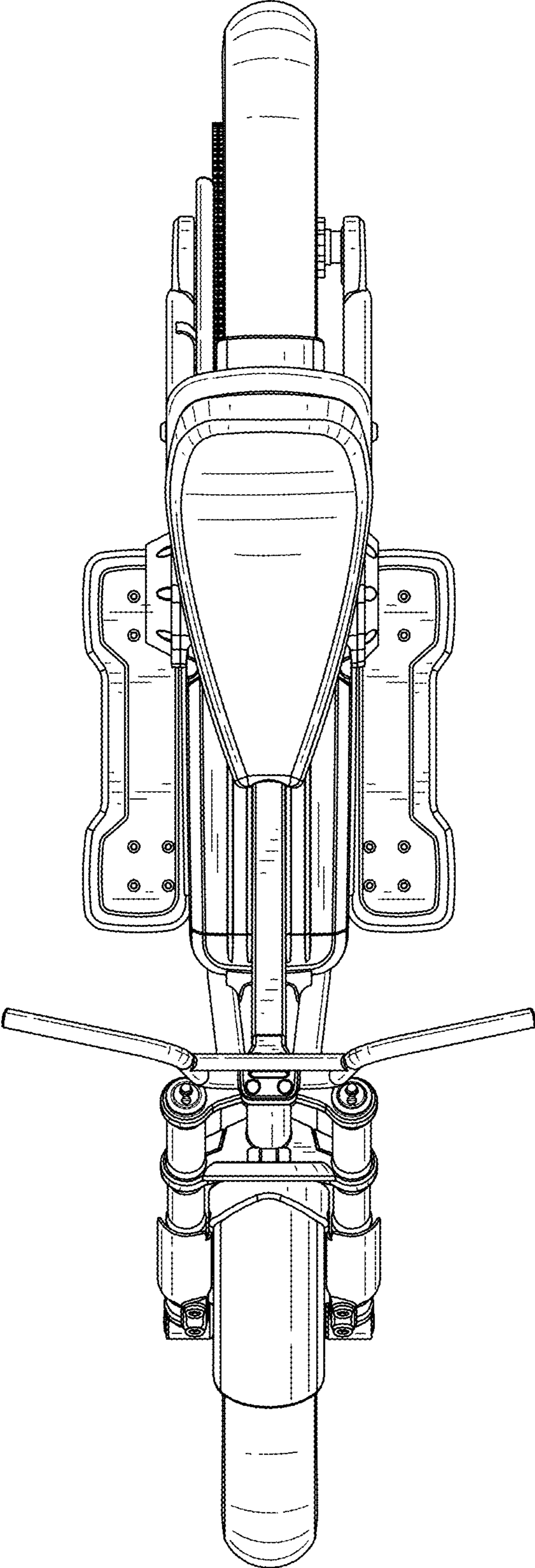

FIG. 7